

CITY OF TAMPA

Citywide Bridge Repair FY 2010–2011

BRIDGE NO'S 105605, 105606, 105625, 105626, 105608
100086, 105600, 105618, 105628, 105629 & More

PROJECT NO. TR 0108

TRANSPORTATION DEPARTMENT
CITY OF TAMPA, FLORIDA

INDEX OF DRAWINGS

SHEET NO	DESCRIPTION
1	Cover Sheet / Index
2	General Notes
3	Bridge Locations Map
4	Plan & Elevation for Bridge (Typical)
5	Bridge Components
6	Bridge Repair Quantities
7	Spall Repair Details
8	Crack Repair Details
9	Joint Repair Details
10	Slope Protection Details

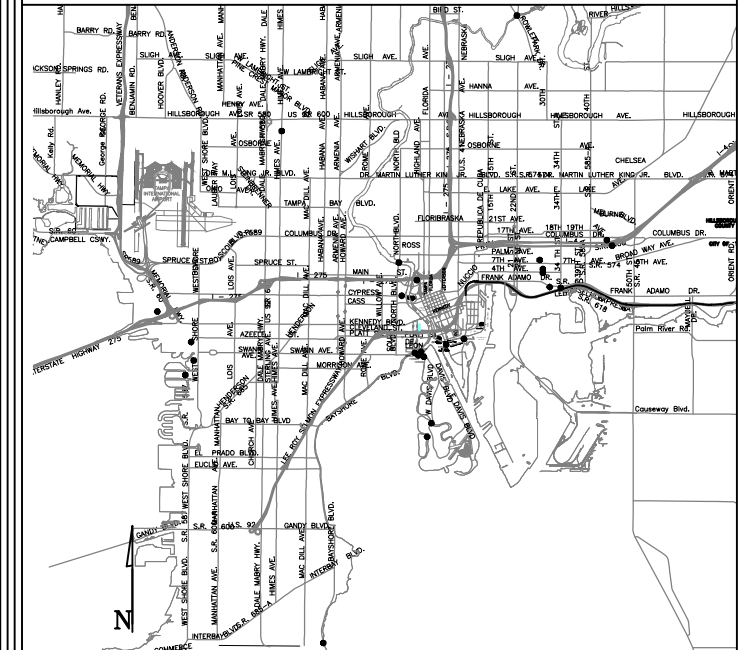

PROJECT LOCATIONS • VICINITY MAP
SCALE: None

STANDARD DRAWINGS & INDICES

THESE PLANS HAVE BEEN PREPARED IN ACCORDANCE WITH AND GOVERNED BY THE CITY OF TAMPA STANDARD DRAWINGS AND WHERE APPLICABLE, FLORIDA DEPARTMENT OF TRANSPORTATION ROADWAY AND TRAFFIC DESIGN STANDARDS (BOOKLET DATED JANUARY, 2010).

258 Straight Sand-cement Endwalls

ALTAFHUSEN H. BUKHARI, P.E. #51877
CITY OF TAMPA PROJECT MANAGER
TRANSPORTATION DIVISION

APPROVED BY:

CERTIFICATION

Sheet 1 to 10 Inclusive, Certified By:

GENERAL NOTES

GENERAL SPECIFICATIONS:

FLORIDA DEPARTMENT OF TRANSPORTATION (FDOT) STANDARD SPECIFICATIONS FOR ROAD AND BRIDGE CONSTRUCTION 2010 EDITION AND IMPLEMENTED MODIFICATIONS THERETO.

DESIGN SPECIFICATION:

1. AMERICAN ASSOCIATION OF STATE HIGHWAY AND TRANSPORTATION OFFICIALS (AASHTO) STANDARD SPECIFICATIONS FOR HIGHWAY BRIDGES (2002 EDITION), WITH APPLICABLE INTERIMS THROUGH 2003.
2. AASHTO STANDARD SPECIFICATIONS FOR MOVABLE HIGHWAY BRIDGES (1988 EDITION).

CONCRETE:

CLASS	MAXIMUM COMPRESSIVE STRESS (PSI)	MINIMUM 28-DAYS COMPRESSIVE STRENGTH (PSI)	DESIGN UNIT WEIGHT INCL. REINFORCING (PCF)	DESIGN MODULUS OF ELASTICITY (KSI)
FC - 2,200		F'C - 5,500	150	3,846
FC - 2,200		F'C - 5,500	150	3,846

REINFORCING STEEL:

ALL REINFORCING STEEL SHALL BE ASTM A615 GRADE 60, UNLESS OTHERWISE INDICATED ON PLANS.

CONCRETE DETAILS:

1. PROVIDE 3/4" CHAMFERS ON ALL EXPOSED EDGES EXCEPT AS OTHERWISE NOTED.
2. CONSTRUCTIONS JOINTS WILL BE PERMITTED ONLY AT LOCATIONS INDICATED ON PLANS. ADDITIONAL CONSTRUCTION JOINTS OR ALTERATIONS TO THOSE SHOWN SHALL REQUIRE WRITTEN APPROVAL OF THE ENGINEER.
3. ALL DIMENSIONS PERTAINING TO LOCATIONS OF REINFORCING ARE TO CENTERLINE OF BARS EXCEPT WHERE THE CLEAR DIMENSION IS SHOWN TO FACE OF REINFORCING BAR.

EF	DENOTES	"EACH FACE"
NF	DENOTES	"NEAR FACE"
FF	DENOTES	"FAR FACE"
T&B	DENOTES	"TOP AND BOTTOM"
CL	DENOTES	"CLEAR"

BONDING COMPOUND:

BONDING COMPOUND SHALL BE APPLIED TO ALL SET CONCRETE PRIOR TO PLACING NEW CONCRETE UNLESS OTHERWISE NOTED. BONDING COMPOUND SHALL BE TYPE "A" OR "F" EPOXY COMPOUND MEETING THE REQUIREMENTS OF SECTION 926 OF THE GENERAL SPECIFICATIONS. BONDING COMPOUNDS SHALL BE MIXED, APPLIED TO A PROPERLY PREPARED SURFACE AND CURED IN STRICT ACCORDANCE WITH THE MANUFACTURER'S RECOMMENDATIONS.

BRIDGE GENERAL NOTES:

DIMENSIONS SHOWN IN THE CONTRACT PLANS WERE OBTAINED FROM FIELD OBSERVATION, AND PREVIOUS CONTRACT PLANS AND SHOP DRAWINGS AND ARE INTENDED FOR INFORMATION AND ESTIMATING PURPOSES ONLY. THE CONTRACTOR IS RESPONSIBLE FOR FIELD VERIFICATION OF ALL DIMENSIONS AND CONDITIONS REQUIRED TO PERFORM THE RENOVATIONS. FAILURE BY THE CONTRACTOR TO FIELD VERIFY DIMENSIONS WILL NOT BE A JUSTIFICATIONS FOR CLAIMS.

2. MANUFACTURER'S REFERENCES & SUBSTITUTIONS:

REFERENCE TO A PARTICULAR MANUFACTURER, TRADE NAME, OR CATALOG NUMBER ESTABLISHES THE QUALITY STANDARDS OF MATERIAL AND EQUIPMENT REQUIRED FOR THIS INSTALLATION AND IS NOT INTENDED TO EXCLUDE PRODUCTS EQUAL IN QUALITY AND SIMILAR DESIGN. WHENEVER A MATERIAL OR EQUIPMENT IS DEFINED BY SPECIFYING A PROPRIETARY PRODUCT OR MANUFACTURER OR VENDOR NAME, THE TERM "OR APPROVED EQUAL," IF NOT INSERTED SHALL BE IMPLIED.

EQUIVALENT PRODUCTS MAY BE SUBSTITUTED BY THE CONTRACTOR, SUBSEQUENT TO THE PRODUCT BEING SUBMITTED FOR APPROVAL, PROVIDED THE CHANGE IS AT NO ADDITIONAL COST TO THE CITY.

3. WORKING DRAWINGS:

THE CONTRACTOR SHALL SUBMIT DETAILED SHOP DRAWINGS AND/OR MANUFACTURER'S LITERATURE FOR ALL NEW STRUCTURAL COMPONENTS TO BECOME PART OF THE FINAL STRUCTURE AND FACILITIES. SUCH DRAWINGS SHALL INCLUDE ALL DIMENSIONS, FITS, FINISHES, MATERIALS, AND SPECIAL INSTRUCTIONS REQUIRED TO PROPERLY CONSTRUCT, FABRICATE, AND INSTALL THESE COMPONENTS. FIELD VERIFIED DIMENSIONS SHALL BE SHOWN AND CLEARLY IDENTIFIED AS SUCH IN THE SHOP DRAWINGS.

4. DESIGN METHODS:

SERVICE LOAD DESIGN METHOD (ALLOWABLE STRESS DESIGN).

PAY ITEM NOTES:

1. PAYMENT FOR INCIDENTAL ITEMS NOT SPECIFICALLY COVERED IN THE INDIVIDUAL PAY ITEMS SHALL BE INCLUDED IN THE CONTRACT UNIT PRICES FOR PAY ITEMS.

3			DES: AHB	 CITY OF TAMPA TRANSPORTATION DEPARTMENT	Transportation Civil Drafting	W.O. TR0108	GENERAL NOTES
2		DRN: L.Z.H.	Citywide Bridge Repair FY 2010-2011			Sh. 2	
1		CKD: MJC				of 10	
No.	DATE	REVISIONS	DATE: 2/14/11				

pw70 :k:\Bridge Maintenance\Citywide Bridge Repair FY 2010-2011.dwg
Layout-2 Plotted- Feb. 14, 2011 11:45 AM

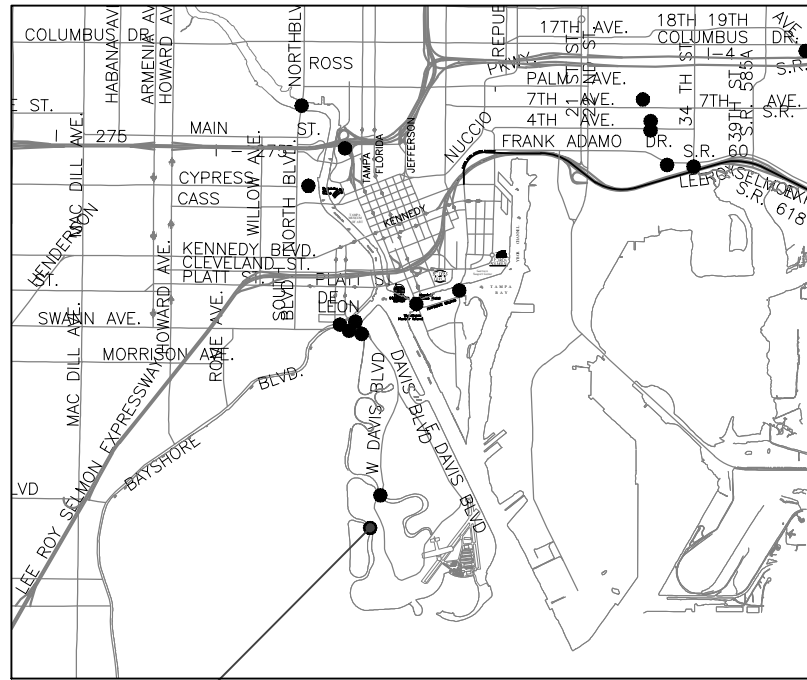

PROJECT LOCATION
(TYP.)

VICINITY MAP
SCALE: None

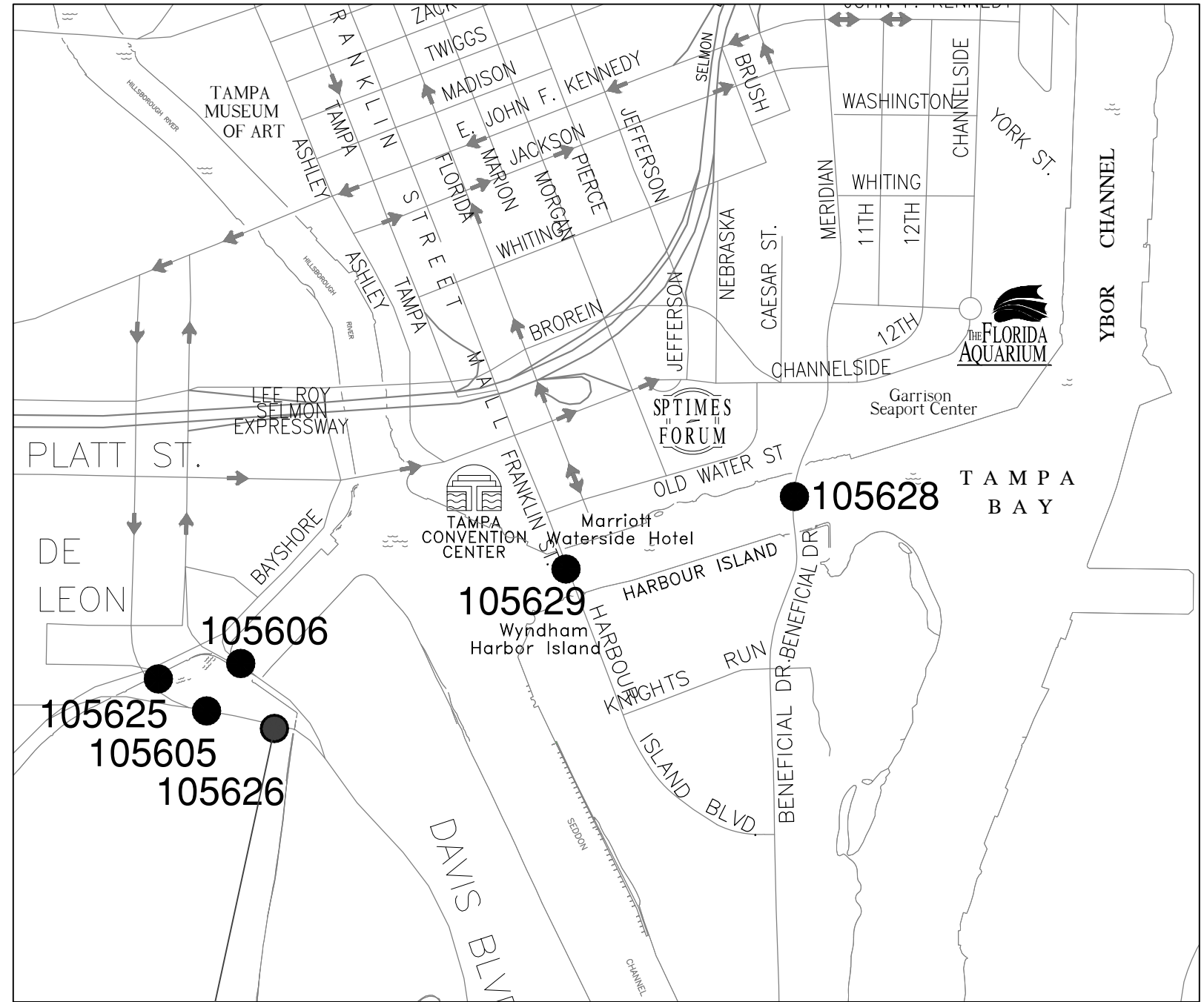

PROJECT LOCATION
(TYP.)

DETAIL
(not to scale)

pw70 :k:\Bridge Maintenance\Citywide Bridge Repair FY 2010-2011.dwg
Layout-3 Plotted- Feb. 14, 2011 11:45 AM

3			DES: AHB	CITY OF TAMPA TRANSPORTATION DEPARTMENT	Transportation Civil Drafting	w.o. TR0108	BRIDGE LOCATIONS MAP
2			DRN: L.Z.H.			Citywide Bridge Repair FY 2010-2011	
1			CKD: MJC		of 10		
No.	DATE	REVISIONS	DATE: 2/14/11				

pw70 :k:\Bridge Maintenance\Citywide Bridge Repair FY 2010-2011.dwg
 Layout-4 Plotted- Feb. 14, 2011 11:45 AM

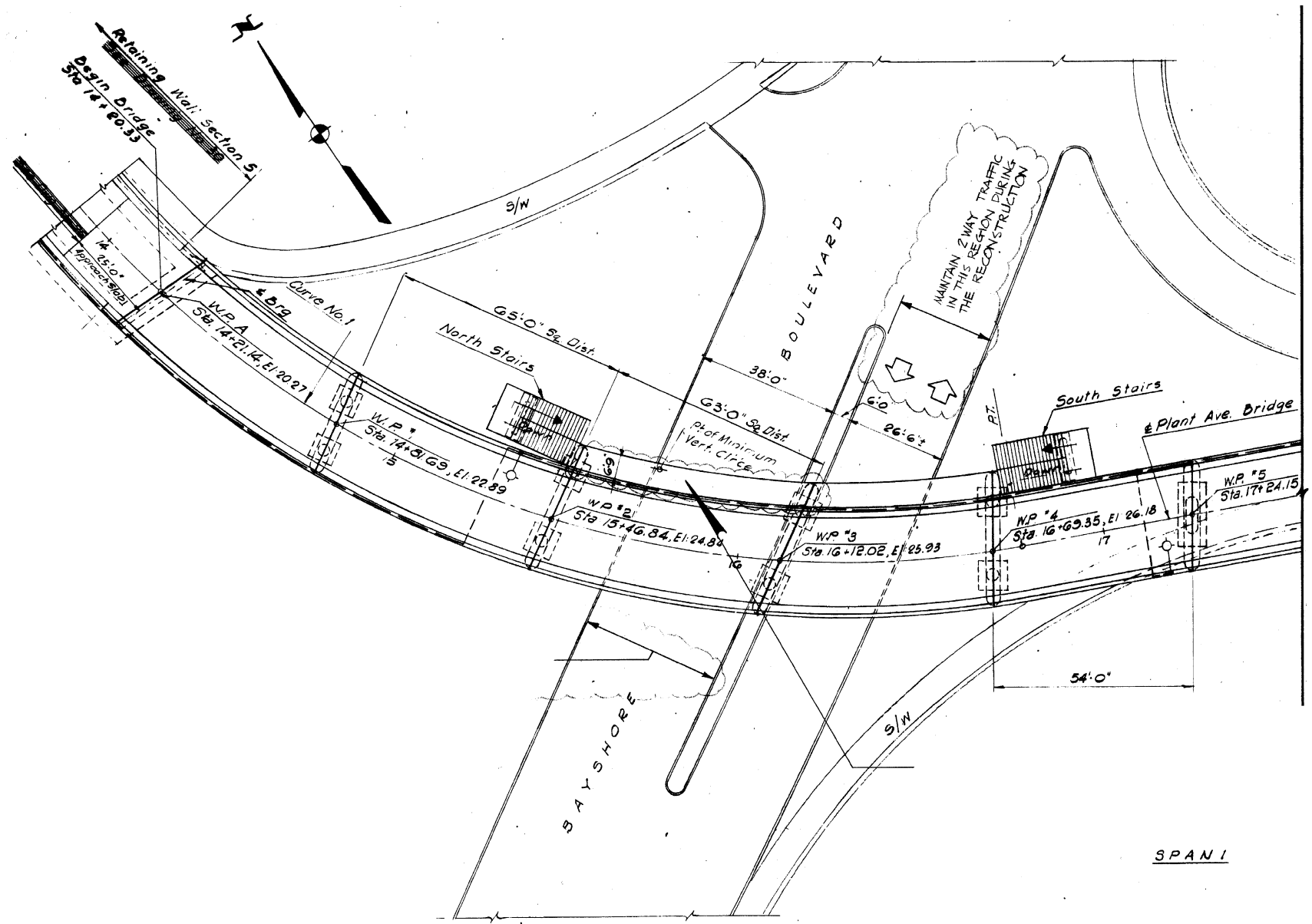

PARTIAL PLAN
 Scale: 1" = 40.0'

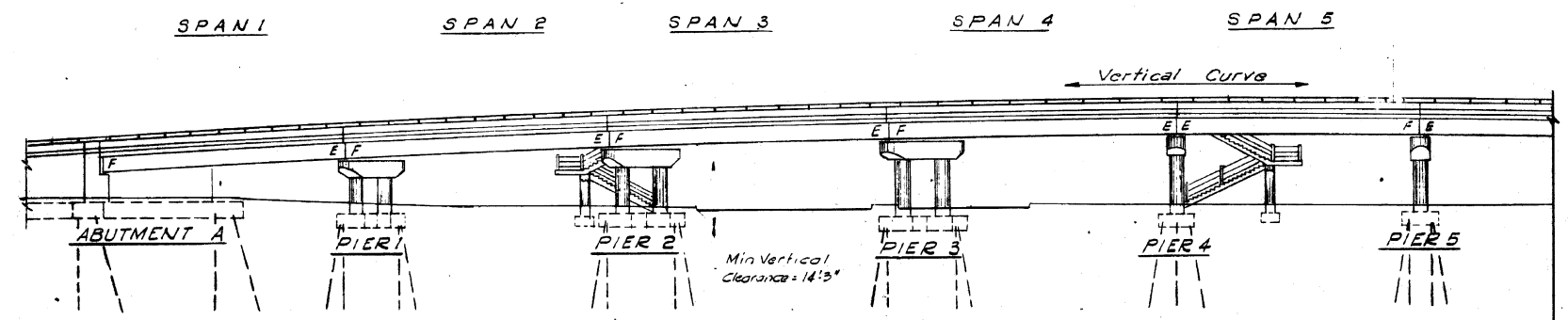

PARTIAL ELEVATION
 Scale: 1" = 40.0'

- LEGEND**
- Denotes 2" PVC Conduit
 - Denotes Lighting Standard
 - F Denotes Fixed Bearing
 - E Denotes Expansion Bearing

3		DES: AHB	 CITY OF TAMPA TRANSPORTATION DEPARTMENT	Transportation Civil Drafting Citywide Bridge Repair FY 2010-2011	w.o. TR0108	PLAN & ELEVATION FOR BRIDGE (TYPICAL)
2		DRN: L.Z.H.			Sh. 4	
1		CKD: MJC			of 10	
No.	DATE	REVISIONS	DATE: 2/14/11			

pw70 : K:\Bridge Maintenance\Citywide Bridge Repair FY 2010-2011.dwg
Layout-5 Plotted- Feb. 14, 2011 11:45 AM

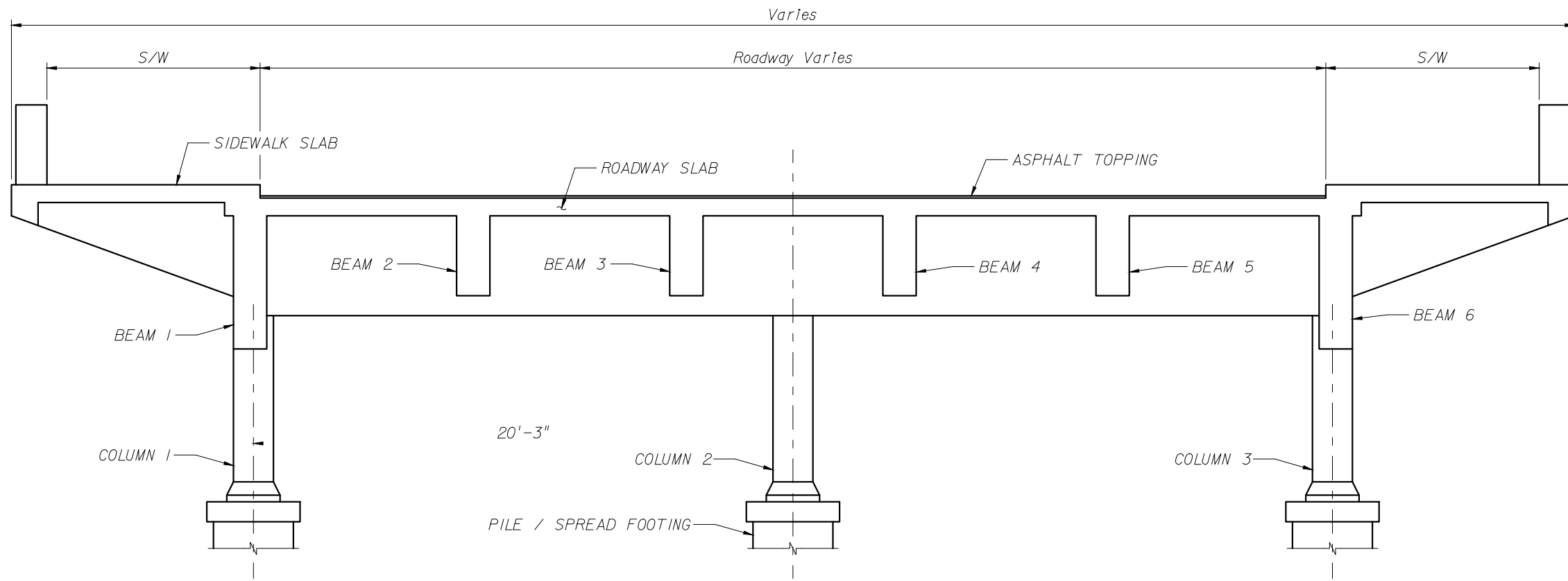

TYPICAL SECTION AT INTERMEDIATE PIERS
(LOOKING EAST)

NOTE: BEAMS AS NUMBERED BY SPAN AND BEAM, EXAMPLE II-1, SPAN II, BEAM 1.
COLUMNS ARE NUMBERED BY PIER AND COLUMN, EXAMPLE 6-3, PIER 6, COLUMN 3.

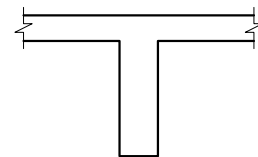

SECTION A-A

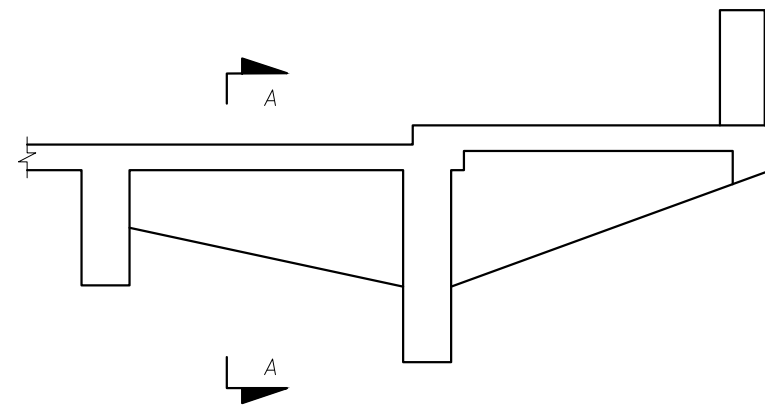

PARTIAL TYPICAL SECTION AT MIDSPAN

Scale: 1" = 5'

3			DES: AHB
2			DRN: L.Z.H.
1			CKD: MJC
No.	DATE	REVISIONS	DATE: 2/14/11

CITY OF TAMPA
TRANSPORTATION
DEPARTMENT

Transportation Civil Drafting
Citywide Bridge Repair FY 2010-2011

w.o. TR0108
sh. 5
of 10

BRIDGE COMPONENTS

pw70 :K: \Bridge Maintenance\Citywide Bridge Repair FY 2010-2011 Qty.dwg
 Layout- 6 Plotted- Feb. 14, 2011 11:45 AM sheet size ANSI expand B (11.00 x 17.00 inches)

Bridge No	Bridge Name	Bridge Location	Spall Repair (C.F.)	Crack Repair		Joint Repair (L.F.)	Slope Protection (C.Y.)
				CRACK L.F.	EPOXY GAL.		
100086	CR 585 Rowlett Park Drive	N.N.E. Tampa / Hillsborough River	2	100	1	---	35
105600	Eugene Holtsinger Bridge	North Blvd. at Hillsborough River	8	1600	16	---	100
105605	Davis Island Bridge	Bayshore Blvd. / Hyde Park Ave.	15	500	5	230	---
105606	Plant Avenue Bridge	North Bayshore Blvd. / Upper Hillsborough Bay	15	500	5	---	---
105608	West Davis Boulevard Bridge	West Davis Island	10	---		102	---
105610	Ashley Street Ramp	Ashley St. Ramp to I-275	3	100	1	---	---
105612	31st Street / 29th Street Outfall	31st / 29th Streets at SR-60 (Adamo Dr.)	15	---		---	---
105613	Dixie Plywood Driveway	SR-60 & Dixie Plywood	---	---		---	---
105618	Andros Drive	Culbreath Isles	2	---		---	---
105622	Bayshore Boulevard / Crayfish Camp	0.6 Mile N of MacDill AFB	---	---		---	284
105623	Garden Club Drive / Lily Canal	25 ft E. of Grove Park Ave.	2	---		---	---
105625	On-Ramp to Davis Island Boulevard	North Bayshore Blvd. / Upper Hillsborough Bay	9	---		---	---
105626	Off-Ramp to Tampa General Hospital	Davis Island Blvd. Exit / T.G.H.	6	---		---	---
105627	Neptune Way / Shorecrest Canal	0.1 Mile W/O Westshore Blvd.	1	---		---	30
105628	Beneficial Drive / Garrison Channel	0.2 mile S. of Channelside Dr.	---	50	0.5	---	310
105629	S. Harbour Island Blvd. / Garrison Channel	0.2 Mi S/O Channelside Dr.	---	50	0.5	---	---
105902	4th Avenue Box Culvert	4th Ave., 1/10 mile W of CSX-RR	2	50	0.5	---	---
105903	5th Avenue Box Culvert / 29th Street	5th Ave. at 29th St., 0.1 Mi West of CSX-RR	---	50	0.5	---	---
105904	8th Avenue Box Culvert	8th Ave., 290 ft E of N 27th Street	---	---		---	---
105906	Apex Drain at 43rd Street	43rd St. at Columbus Dr.	---	---		---	---
105907	Rathole Branch	60 yd.s West of 45th Street	---	---		---	---
105908	Reo Street / Saltwater Bayou	Reo St, 65' S of Cypress St.	3	---		---	---
105912	Himes Avenue over Rusty Canal	Himes Ave., 0.2 Mi S. of Hillsborough Ave.	---	---		---	---
105913	Cypress Street / Drainage Canal	In Julian B. Lane Park	5	---		---	---
105914	Riviera Drive / Coquimba Channel	West Davis Islands	---	---		---	---
105915	New Tampa Boulevard / Trout Creek	New Tampa Blvd., 0.4 Mi West of CR-581	2	---		---	---

3		DES: AHB
2		DRN: L.Z.H.
1		CKD: MJC
No.	DATE	REVISIONS
		DATE: 2/14/11

CITY OF TAMPA
 TRANSPORTATION
 DEPARTMENT

Transportation Civil Drafting

Citywide Bridge Repair FY 2010-2011

W.O. TR0108

Sh. 6
of 10

**BRIDGE REPAIR ESTIMATED QUANTITIES
& PRIORITY FOR REPAIR WORK**

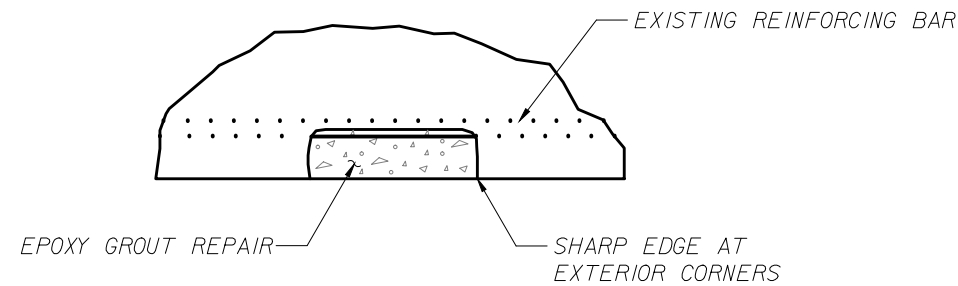

SPALL REPAIR DETAIL ①
(FOR SMALL ISOLATED SPALLS)

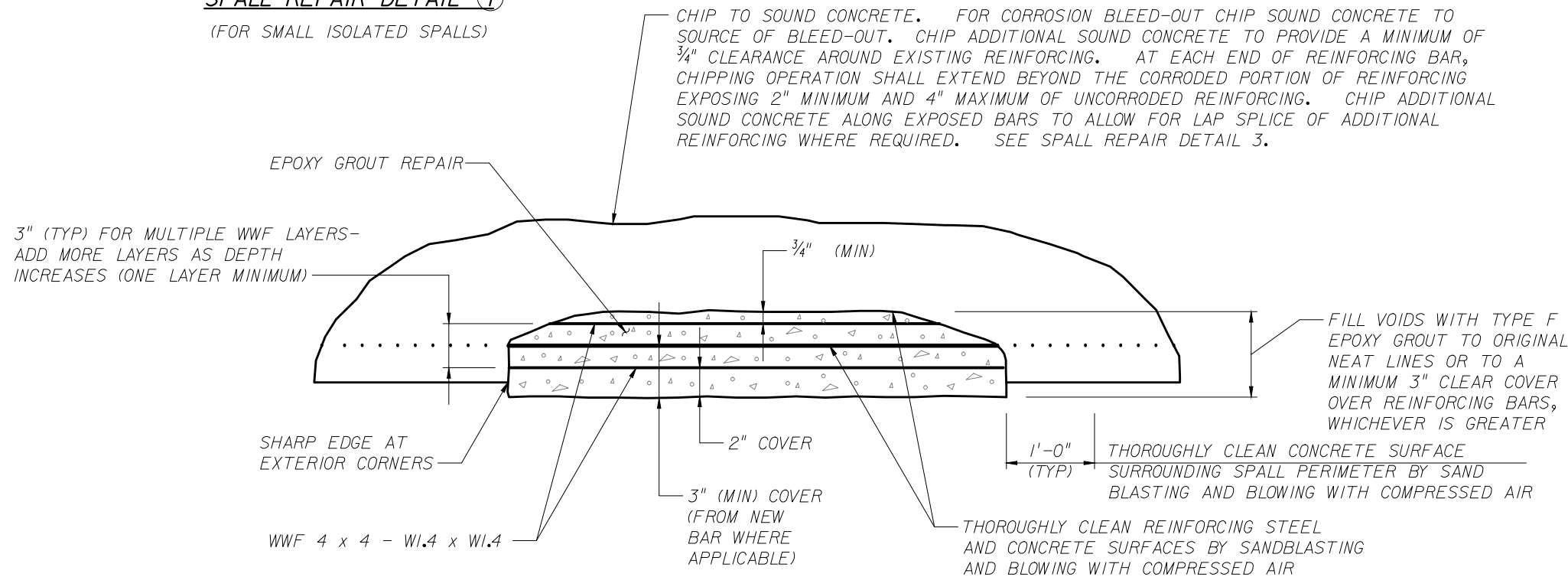

SPALL REPAIR DETAIL ②

COMPLETION OF CLEANING OPERATIONS AND COVERAGE OF REINFORCING STEEL BY EPOXY SHALL OCCUR WITHIN THE SAME DAY

SPALL REPAIR NOTES:

1. CHIP TO SOUND CONCRETE.
2. IF MORE THAN HALF OF PERIMETER OF REINFORCING BAR IS EXPOSED OR BOND AROUND BAR IS BROKEN USE DETAIL 2.
3. THOROUGHLY CLEAN REINFORCING STEEL AND CONCRETE SURFACES BY SANDBLASTING FOLLOWED BY BLOWING WITH COMPRESSED AIR.
4. PRIME THE SURFACE TO BE REPAIRED WITH TYPE F EPOXY, USING STIFF BRUSHES TO WORK INTO SURFACE.
5. WHILE PRIMING MATERIAL IS TACKY, FILL VOIDS WITH TYPE F EPOXY GROUT TO ORIGINAL NEAT LINES.
6. COMPLETION OF CLEANING OPERATIONS AND REPAIR SHALL OCCUR WITHIN THE SAME DAY.

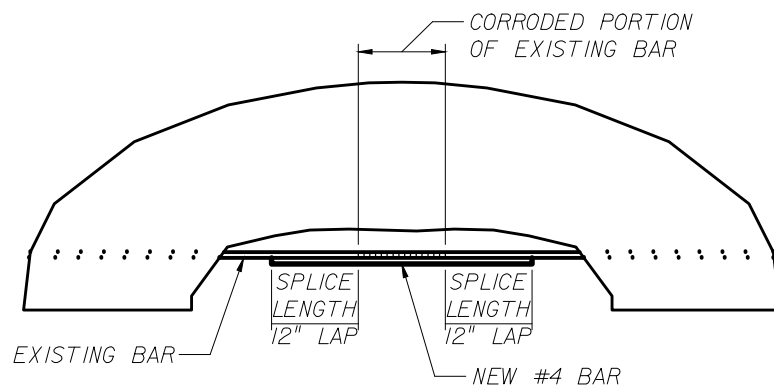

SPALL REPAIR DETAIL ③

SPLICE NOTES:

1. THIS DETAIL IS APPLICABLE WHEN THE EXISTING BAR EXHIBITS A 20% OR GREATER REDUCTION IN ITS CROSS SECTIONAL AREA.
2. FOR THE SPALL REPAIR USE DETAIL 2.

REINFORCING STEEL LAP LENGTHS	
SIZE	LAP
#4	12 INCHES
#5	15 INCHES
#6	18 INCHES

NOTE: AT CONTRACTOR'S OPTION, MORTAR MATERIAL MEETING STANDARD SPECIFICATION SECTION 930, SUITABLE FOR OVERHEAD WORK AND LISTED ON THE FDOT PRE-QUALIFIED PRODUCTS LIST MAY BE SUBSTITUTED FOR EPOXY GROUT. SAID MORTAR SHALL BE USED IN STRICT CONFORMANCE WITH MANUFACTURER'S RECOMMENDATIONS.

NOTES:

1. DETAILS ARE APPLICABLE TO ALL ORIENTATIONS: HORIZONTAL (INCLUDING OVERHEAD) AND VERTICAL.
2. EPOXY COMPOUND SHALL BE SUITABLE FOR OVERHEAD WORK AND SHALL BE LISTED ON THE FDOT QUALIFIED PRODUCTS LIST.
3. SPALL AND CRACK DIMENSIONS AND LOCATIONS ARE APPROXIMATE. REGARDLESS OF THE SIZES NOTED, REPAIR THE ENTIRE DEFICIENCY. THERE MAY BE ADDITIONAL CRACKS AND SPALLS BEYOND THOSE SHOWN. THE CONTRACTOR SHALL PERFORM A THOROUGH INVESTIGATION OF THE STRUCTURE TO LOCATE CRACKS, SPALLS AND DELAMINATION IN THE BRIDGE COMPONENTS, AND REPAIR THOSE AS DIRECTED BY THE ENGINEER.
4. PAYMENT FOR THE COSTS OF THE ABOVE INVESTIGATION SHALL BE INCLUDED IN THE RESPECTIVE ITEMS.

pw70 : K:\Bridge Maintenance\Citywide Bridge Repair FY 2010-2011.dwg
Layout-7
Plotted- Feb. 14, 2011 11:45 AM

3		DES: AHB
2		DRN: L.Z.H.
1		CKD: MJC
No.	DATE	REVISIONS
		DATE: 2/14/11

CITY OF TAMPA
TRANSPORTATION
DEPARTMENT

Transportation Civil Drafting
Citywide Bridge Repair FY 2010-2011

W.O. TR0108
Sh. 7
of 10

SPALL REPAIR DETAILS

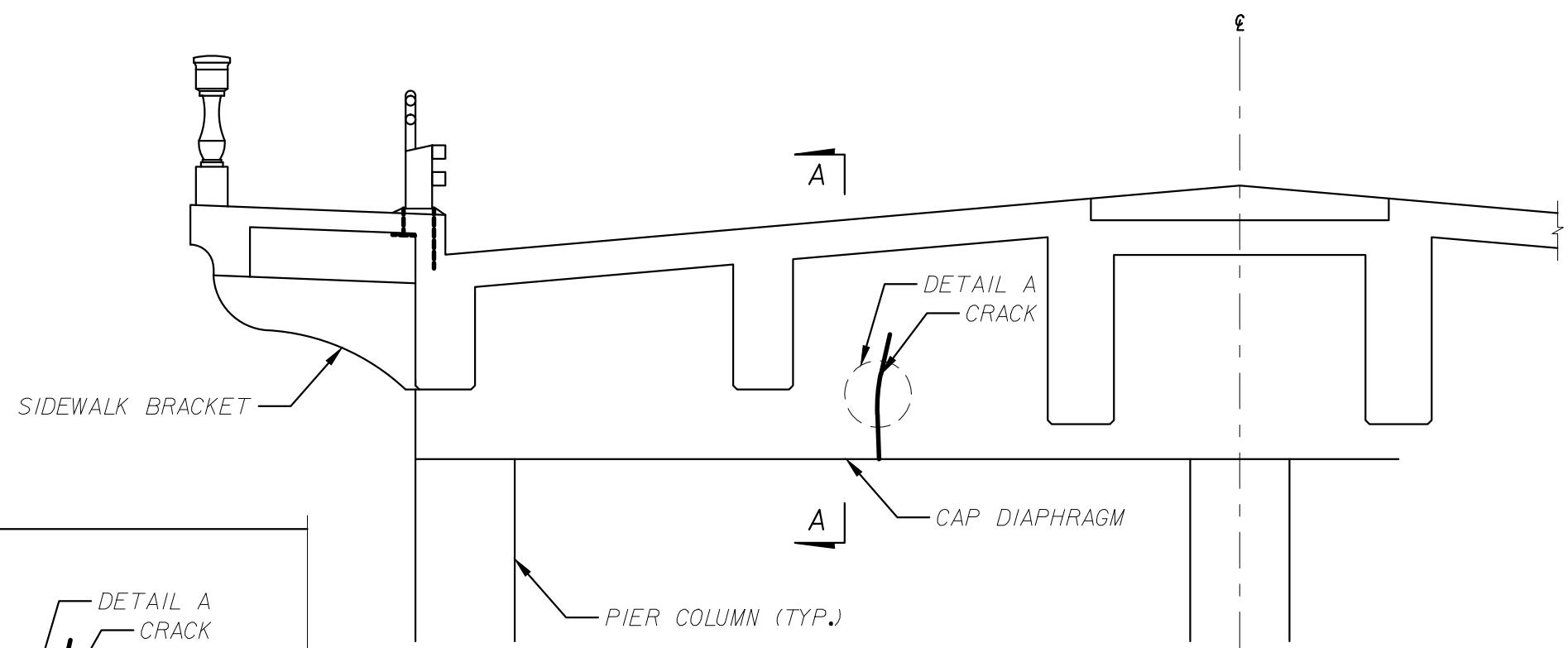

- CONSTRUCTION SEQUENCE:**
 THIS REPAIR PROCEDURE APPLIES TO CONCRETE SUPERSTRUCTURE CAP/DIAPHRAGM AND BEAMS.
1. REMOVE ALL DEBRIS FROM CRACKS.
 2. "V" GROOVE THE CONCRETE SURFACE ALONG THE CRACKS APPROXIMATELY 1/4" IN DEPTH.
 3. DRILL APPROXIMATELY 1/8" TO 3/4" DIAMETER HOLES FOR INJECTION PORTS. THE HOLES SHOULD BE SPACED 4" TO 8" ON CENTER ALONG THE CRACKS. REMOVE ALL DEBRIS WITH HIGH PRESSURE AIR BLASTING.
 4. INSERT INJECTION PORTS IN THE DRILLED HOLES APPROXIMATELY 1/2" DEEP.
 5. SEAL SURFACE OF CRACK WITH TYPE F-1 EPOXY COMPOUND. EXTEND ABOVE CONCRETE SURFACE A MINIMUM OF 1/16" AND EXTEND A MINIMUM OF 1" TO EITHER SIDE OF CRACK. ALLOW A MINIMUM OF SIX HOURS CURING BEFORE INITIATING INJECTION PROCESS.
 6. INJECT THE TYPE E EPOXY COMPOUND PER STANDARD SPECIFICATIONS 411. ALLOW A MINIMUM OF SIX HOURS CURING TIME.
 7. REMOVE AND CLEAN EPOXY PASTE AND SEALER IN A MANNER THAT WILL NOT DAMAGE CONCRETE SURFACE.

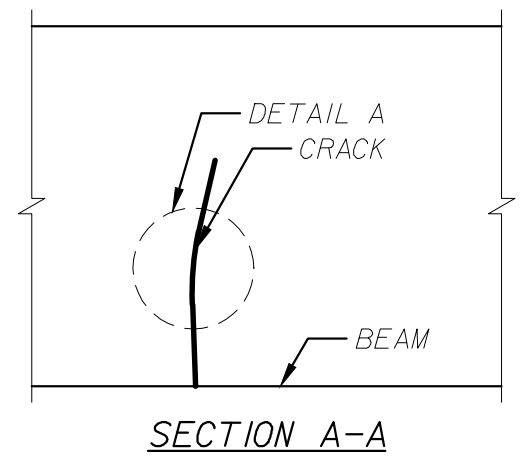

CRACK REPAIR ELEVATION VIEW

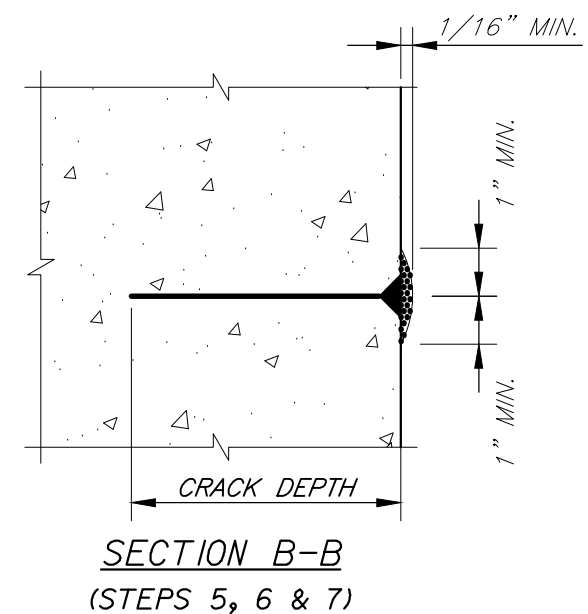
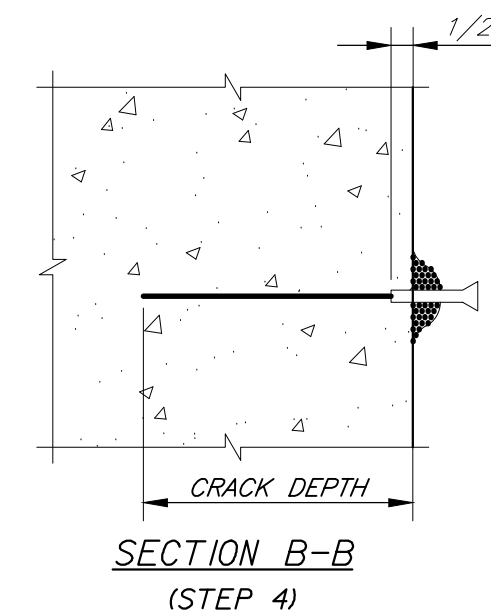
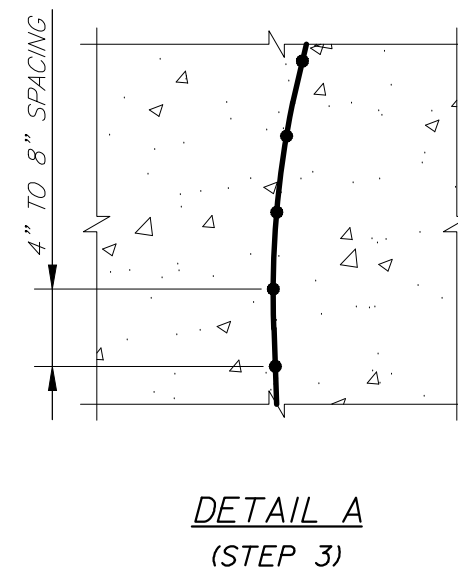
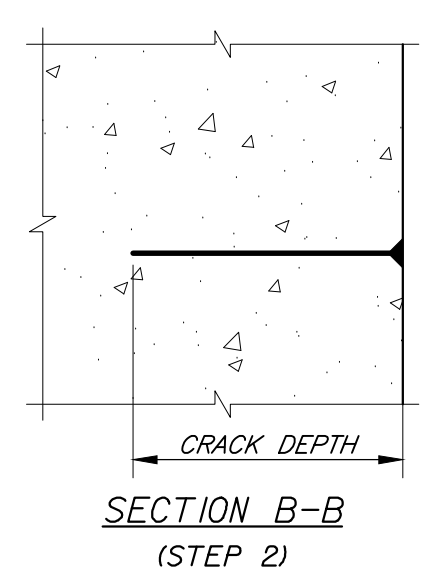
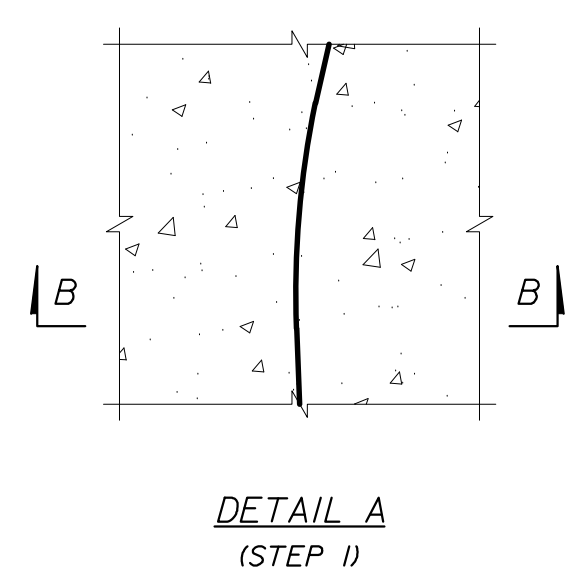

pw70 : K:\Bridge Maintenance\Citywide Bridge Repair FY 2010-2011.dwg
 Layout-8 Plotted- Feb. 14, 2011 11:45 AM

No.	DATE	REVISIONS
3		
2		
1		

DES: AHB
 DRN: L.Z.H.
 CKD: MJC
 DATE: 2/14/11

CITY OF TAMPA
 TRANSPORTATION
 DEPARTMENT

Transportation Civil Drafting
 Citywide Bridge Repair FY 2010-2011

w.o. TR0108
 Sh. 8
 of 10

CRACK REPAIR DETAILS

pw70 : K:\Bridge Maintenance\Citywide Bridge Repair FY 2010-2011.dwg
 Layout-9 Plotted- Feb. 14, 2011 11:45 AM

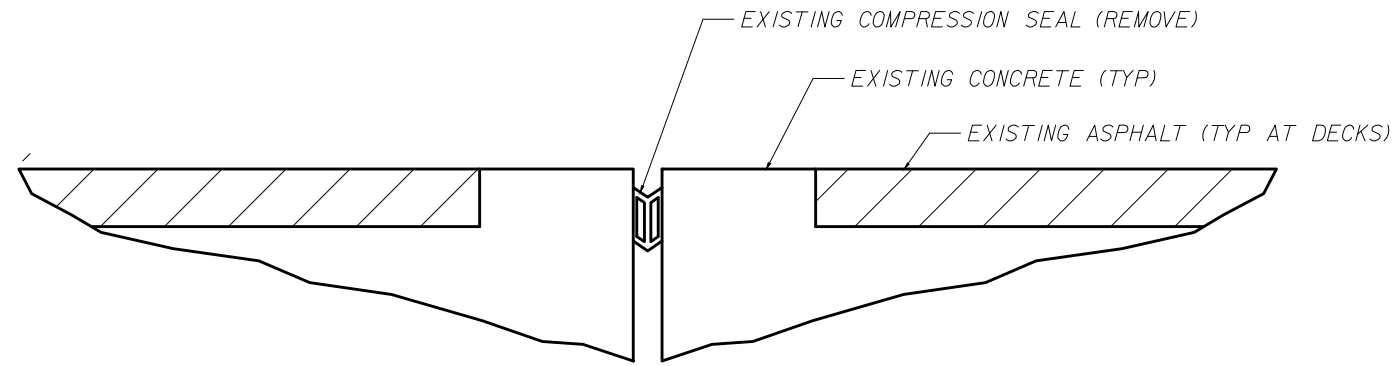

EXISTING DECK JOINTS
 (DECKS OR SIDEWALKS)

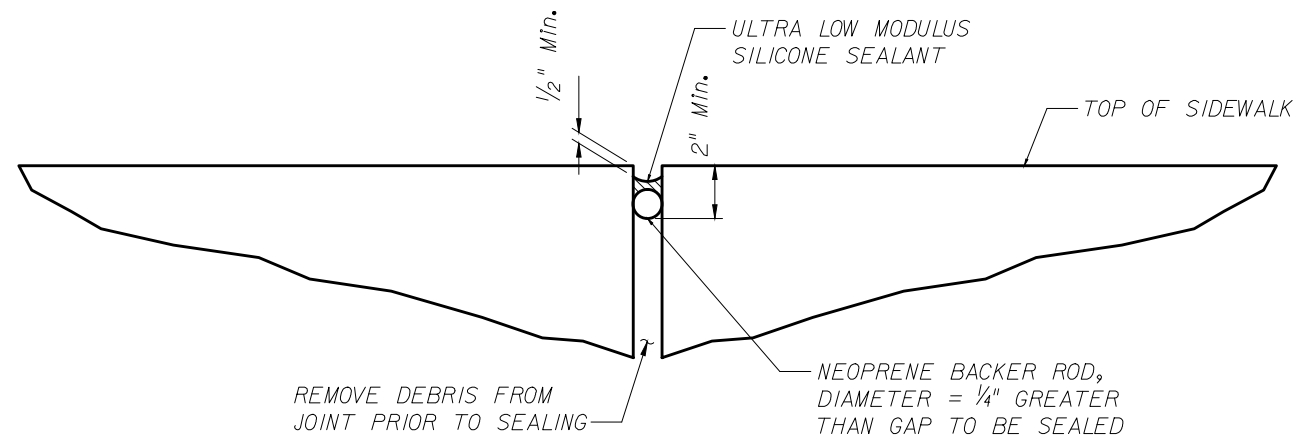

REPAIR DETAIL A

(SEALANT DETAIL AT DECK OR SIDEWALKS)

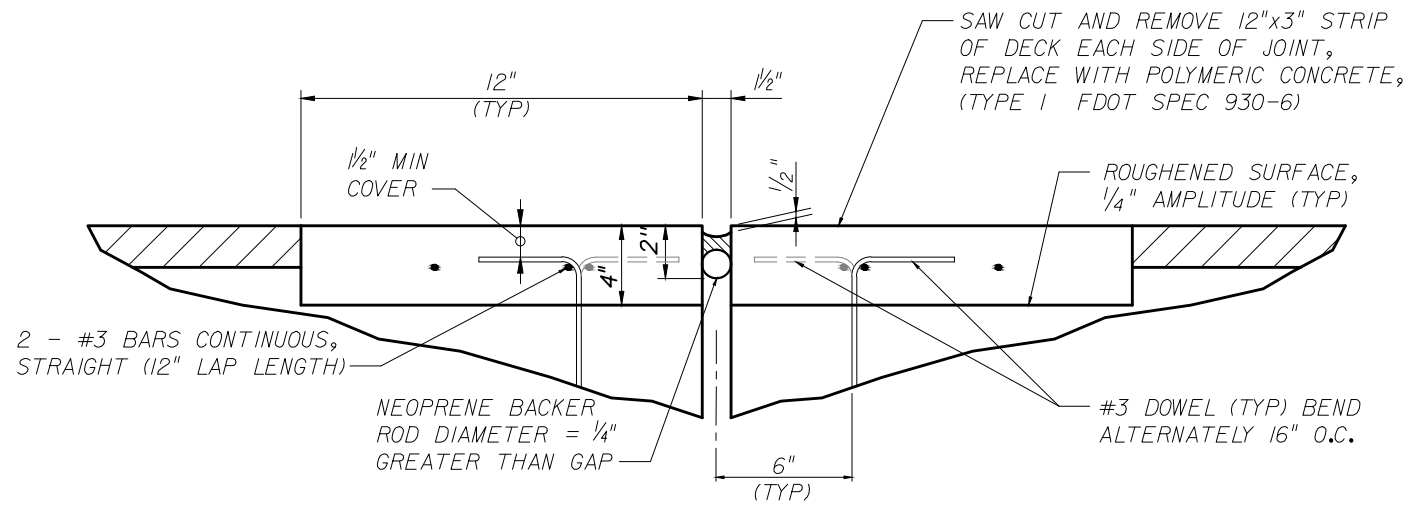

REPAIR DETAIL B

(DECK JOINT REHABILITATION)

3		DES: AHB
2		DRN: L.Z.H.
1		CKD: MJC
No.	DATE	REVISIONS
		DATE: 2/14/11

CITY OF TAMPA
 TRANSPORTATION
 DEPARTMENT

Transportation Civil Drafting
 Citywide Bridge Repair FY 2010-2011

W.O. TR0108
 Sh. 9
 of 10

JOINT REPAIR DETAILS

pw70 : K:\Bridge Maintenance\Citywide Bridge Repair FY 2010-2011.dwg
Layout- 10 Plotted- Feb. 14, 2011 11:45 AM

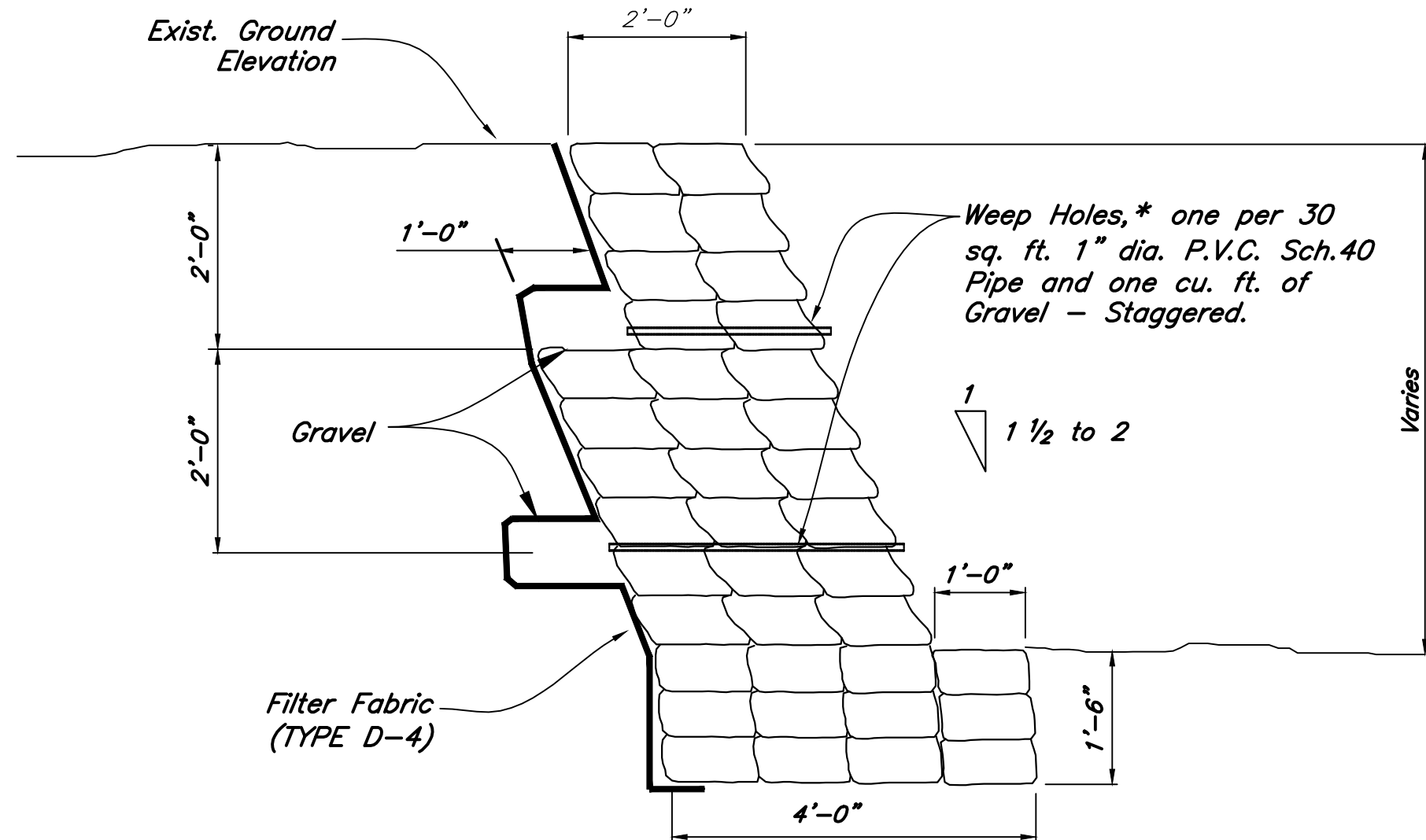

NOTE: * Lower Weep Hole is included when depth between top and bottom of the ditch is greater than 4'-0"
Secure bags with bars per FDOT Std Index 258.

TYPICAL CROSS SECTION OF SAND-CEMENT
RIP-RAP RETAINING WALL
N.T.S.

3		DES: AHB	CITY OF TAMPA TRANSPORTATION DEPARTMENT	Transportation Civil Drafting	w.o. TR0108	SLOPE PROTECTION DETAILS
2		DRN: L.Z.H.				
1		CKD: MJC				
No.	DATE	REVISIONS	DATE: 2/14/11	Citywide Bridge Repair FY 2010-2011	Sh. 10 of 10	