

CITY OF
TAMPA, FLORIDA

NOTICE TO BIDDERS, INSTRUCTIONS TO BIDDERS
PROPOSAL, BID BOND, FORM OF NOTICE OF AWARD,
AGREEMENT, PERFORMANCE BOND AND
SPECIFICATIONS

FOR

Contract 22-C-00034

Citywide Meter, Hydrant and Valve Installation and Replacement

City of Tampa
CONTRACT ADMINISTRATION DEPARTMENT
TAMPA MUNICIPAL OFFICE BUILDING
306 E. JACKSON STREET - 4TH FLOOR NORTH
TAMPA, FLORIDA 33602

JULY 2022

CITY OF TAMPA
CONTRACT ADMINISTRATION DEPARTMENT
306 E. Jackson Street 280A4N
Tampa, FL 33602

BID NOTICE MEMO

Electronic Bids are not allowed for these projects.

Physical Bids will be received no later than 1:30 p.m. at the above address on the indicated Date(s) for the following Project(s):

CONTRACT NO.: 22-C-00034; Citywide Meter, Hydrant, and Valve Installation and Replacement

BID OPENING: 1:30PM, Tuesday, August 30, 2022, **ESTIMATE:** \$6,500,000 **SCOPE:** Furnishing and installing water mains and appurtenances ranging in size from 2-inch to 16-inch diameter including concrete masonry, curbs and sidewalks; paving, landscaping, grouting, brick street construction.

Bids will be opened in the 4th Floor Conference Room, Tampa Municipal Office Building, 306 E. Jackson Street, Tampa, Florida 33602. The public is not allowed to attend in person.

To view the Bid Opening follow these instructions:
To join the meeting from your computer, tablet or smartphone.

<https://global.gotomeeting.com/join/173279197>

You can also dial in using your phone. (For supported devices, tap a one-touch number below to join instantly.)
United States: +1 (646) 749-3131 - One-touch: tel:+16467493131,,173279197#

Access Code: 173-279-197

Join from a video-conferencing room or system. Dial in or type: 67.217.95.2 or inroomlink.goto.com
Meeting ID: 173 279 197 Or dial directly: 173279197@67.217.95.2 or 67.217.95.2##173279197

New to GoToMeeting? Get the app now and be ready when your first meeting starts:

<https://global.gotomeeting.com/install/173279197>

In accordance with the Americans with Disabilities Act ("ADA") and Section 286.26, Florida Statutes, persons with disabilities needing a reasonable accommodation to participate in this public hearing or meeting should contact the City of Tampa's ADA Coordinator at least 48 hours prior to the proceeding. The ADA Coordinator may be contacted by phone at 813-274-3964, email at TampaADA@tampagov.net, or by submitting an ADA - Accommodations Request online form available at <http://www.tampagov.net/ADARquest>.

Please note that the City of Tampa may not be able to accommodate any request received less than 48 hours before the scheduled public hearing or meeting.

Plans and Specifications and Addenda for this work may be examined at, and downloaded from, www.demandstar.com.
Files are also available at <http://www.tampagov.net/contract-administration/programs/construction-project-bidding>.

Email Questions to: contractadministration@tampagov.net .

TABLE OF CONTENTS

BIDDING REQUIREMENTS

| | |
|--|------------------|
| Notice to Bidders | N-1 |
| Instructions to Bidders..... | I-1a thru I-4 |
| Insurance Requirements..... | INS-1 thru INS-2 |
| MBD Form 70 | 1 Page |
| WMBE-SLBE Availability Contact List..... | ACL-1 |
| Availability Contact List Instructions | ACLI-1 |

BID FORMS

| | |
|---|-----------------|
| Proposal..... | P-1 thru P-6 |
| Good Faith Efforts Compliance Plan..... | GFECF |
| SLBE Solicited | DMI – Solicited |
| SLBE Utilized..... | DMI – Utilized |
| Bid Bond | BB-1 |

CONTRACT FORMS

| | |
|--------------------------------|----------------|
| Agreement | A-1 thru A-15 |
| Public Construction Bond | PB-1 thru PB-3 |

GENERAL PROVISIONS

| | |
|----------------------------------|--------------------|
| General Provisions | G-1 thru G-10 |
| Specific Provisions..... | SP-1- thru SP-24 |
| Subcontractors Payment Form..... | DMI – Payments |
| Project Sign..... | Sign-1 thru Sign-2 |

SPECIFICATION

| | |
|---|-----------------|
| CONTRACT PAY ITEMS..... | CP-1 thru CP-34 |
| WATER TECHNICAL AND MATERIAL SPECIFICATIONS | WM-1 thru WM-48 |
| CITY OF TAMPA WATER DEPARTMENT STANDARD DETAILS | 2.01A thru 8.03 |

NOTICE TO BIDDERS
CITY OF TAMPA, FLORIDA
Contract 22-C-00034; Citywide Meter, Hydrant and Valve Installation and Replacement

Sealed Proposals will be received by the City of Tampa no later than 1:30 P.M., August 30, 2022, in the 4th Floor Conference Room, Tampa Municipal Office Building, 306 E. Jackson Street, Tampa, Florida, there to be publicly opened and read aloud.

The proposed work is to include, but not be limited to, furnishing and installing water mains and appurtenances ranging in size from 2-inch to 16-inch diameter including concrete masonry, curbs and sidewalks; paving, landscaping, grouting, brick street construction with all associated work required for a complete project in accordance with the Contract Documents.

The Instructions to Bidders, Proposal, Form of Bid Bond, Agreement, Form of Public Construction Bond, Specifications, Plans and other Contract Documents are posted at DemandStar.com. Backup files may be downloaded from <http://www.tampagov.net/contract-administration/programs/construction-project-bidding>. One set may be available for reference at the office of the Contract Administration Department, Municipal Office Building, Fourth Floor North, City Hall Plaza, Tampa, Florida 33602.

Each Proposal must be submitted on the Proposal form included in the Specifications and must be accompanied by a certified check or cashier's check on a solvent bank or trust company in compliance with Section 255.051, Florida Statutes, made payable to the City of Tampa, in an amount of not less than five per cent of the total bid, or a Bid Bond, of like amount, on the form set forth in the Contract Documents, as a guarantee that, if the Proposal is accepted, the Bidder will execute the Proposed Contract and furnish a Public Construction Bond within twenty (20) days after receipt of Notice of Award of Contract.

To be eligible to submit a proposal, a Bidder must hold the required and/or appropriate current license, certificate, or registration (e.g. DBPR license/certificate of authorization, etc.) in good standing at the time of receipt of Bids. **Per Section 489.131, Florida Statutes, Proposals submitted for the construction, improvement, remodeling, or repair of public projects must be accompanied by evidence that the Bidder holds the required and/or appropriate current certificate or registration, unless the work to be performed is exempt under Section 489.103, Florida Statutes.**

The City of Tampa reserves the right to reject any or all Bids and to waive any informalities in the Bid and/or Bid Bond. Acceptance or rejection of Proposals will be made as soon as practicable after the Proposals are received, but the City reserves the right to hold Proposals for ninety (90) days from the date of Opening.

Bid Protest Procedures: Unless subsequently indicated otherwise, in a revised posting on the Department's web page for Construction Project Bidding, the City of Tampa intends to award the referenced project to the lowest bidder listed in the tabulation posted on or about the date of Bid Opening. A bidder aggrieved by this decision may file a protest not later than 4:30 P.M., five (5) business days from the first posting thereof, pursuant to City of Tampa Code Chapter 2, Article V, Division 3, Section 2-282, Procurement Protest Procedures. Protests not conforming therewith shall not be reviewed.

Pursuant to Section 2-282, City of Tampa Code, during the solicitation period, including any protest and/or appeal, NO CONTACT with City officers or employees is permitted from any bidder or proposer, other than as specifically stated in this solicitation and as follows:
Director of the Contract Administration Department (CAD)
Contracts Management Supervisor, Jim Greiner
Contract Officer, Jody Gray
City legal department

Any Requests For Information must be submitted by email to ContractAdministration@tampagov.net

A person or affiliate who has been placed on the convicted vendor list following a conviction for a public entity crime may not submit a bid on a contract to provide any goods or services to a public entity, may not submit a bid on a contract with a public entity for the construction or repair of a public building or public work, may not submit bids on leases of real property to a public entity, may not be awarded or perform work as a contractor, supplier, subcontractor, or consultant under a contract with any public entity, and may not transact business with any public entity in excess of the threshold amount provided in Section 287.017, for CATEGORY TWO for a period of 36 months from the date of being placed on the convicted vendor list." Refer to Section 287.133, Florida Statutes.

Pursuant to Section 287.087, Florida Statutes, under certain circumstances preference may be given to businesses with a drug-free workplace program that meets the requirements of said Section.

INSTRUCTIONS TO BIDDERS
SECTION 1 - SPECIAL INSTRUCTIONS

I-1.01 GENERAL:

The proposed work is the Citywide Meter, Hydrant and Valve Installation and Replacement in the City of Tampa, as required for a complete project, as shown on the plans and detailed in the specifications. The work is located on land owned or controlled by the City of Tampa.

To be eligible to submit a proposal, a Bidder must hold the required and/or appropriate current license, certificate, or registration (e.g. DBPR license/certificate of authorization, etc.) in good standing at the time of receipt of Bids. **Per Section 489.131, Florida Statutes, Proposals submitted for the construction, improvement, remodeling, or repair of public projects must be accompanied by evidence that the Bidder holds the required and/or appropriate current certificate or registration, unless the work to be performed is exempt under Section 489.103, Florida Statutes.**

I-1.02 FORM PREPARATION AND PRESENTATION OF PROPOSALS: Replace the second sentence with the following: Submission of the entire specification book is not required.

I-1.03 ADDENDA – Section I-2.03 is replaced with the following: No interpretation of the meaning of the Plans, Specifications, or other Contract Documents will be made to any Bidder orally.

Every request for such interpretation must be in writing, addressed to the City of Tampa, Contract Administration Department, 306 E. Jackson St., 4th Floor, Tampa, Florida 33602 and then emailed to ContractAdministration@tampagov.net. To be given consideration, such request must be received at least seven (7) days prior to the date fixed for the opening of the Proposals. Any and all such interpretations and any supplemental instructions will be in the form of written addenda which, if issued, will be posted on DemandStar.Com and on the Department's web page. Failure of any Bidder to receive any such addenda shall not relieve said Bidder from any obligation under his Proposal as submitted. All addenda so issued shall become part of the Contract Documents.

I-1.04 INSTRUCTIONS TO BIDDERS

SECTION 2 – GENERAL INSTRUCTIONS. Section I-2.07 SIGNATURE AND QUALIFICATIONS OF BIDDERS is replaced with the following:

Proposals must be signed in ink by the Bidder with signature in full. When firm is a Bidder, the Proposal shall be signed in the name of the firm by one or more partners. When a corporation is a bidder the officer signing shall set out the corporate name in full beneath which he shall sign his name and give the title of his office.

If the bidder referred to in Section I-2.07 is a corporation, it must submit; upon request, a copy of its filed Articles of Incorporation. In addition, if the bidder was incorporated in another state, it must establish that it is authorized to do business in the State of Florida. If the bidder is using a fictitious name, it must submit upon request, proof of registration of such name with the Clerk of the Circuit Court of the County where its principal place of business is. Failure to submit what is required is grounds to reject the bid of that bidder.

SECTION 2 – GENERAL INSTRUCTIONS. Section I-2.14 NONDISCRIMINATION IN EMPLOYMENT is changed to add the following to the end of the existing text:

The following provisions are hereby incorporated into any contract executed by or on behalf of the City. Contractor shall comply with the following Statement of Assurance: During the performance of the Contract, the Contractor assures the City, that the Contractor is in compliance with Title VII of the 1964 Civil Rights Act, as amended, the Florida Civil Rights Act of 1992, and the City of Tampa Code of Ordinances, Chapter 12, in that Firm/Contractor does not on the grounds of race, color, national origin, religion, sex, sexual orientation, gender identity or expression, age, disability, familial status, or marital status, discriminate in any form or manner against said Firm's/Contractor's employees or applicants for employment. Contractor understands and agrees that the Contract is conditioned upon the veracity of this Statement of Assurance, and that violation of this condition shall be considered a material breach of the Award/Contract. Furthermore, Contractor herein assures the City that said Contractor will comply with Title VI of the Civil Rights Act of 1964 when federal grant(s) is/are

INSTRUCTIONS TO BIDDERS
SECTION 1 - SPECIAL INSTRUCTIONS

involved. This Statement of Assurance shall be interpreted to include Vietnam-Era Veterans and Disabled Veterans within its protective range of applicability. Firm/Contractor further acknowledges and agrees to provide the City with all information and documentation that may be requested by the City from time to time regarding the solicitation, selection, treatment and payment of subcontractors, suppliers and vendors in connection with this Award/Contract. Firm/Contractor further acknowledges that it must comply with City of Tampa Code of Ordinances, Chapter 26.5.

I-1.05 TIME FOR COMPLETION:

The work shall be arranged to be completed in accordance with a progress schedule approved by the Construction Engineer.

The time for completion of this project, referred in Article 4.01 of the Agreement, shall be 365 consecutive calendar days. The period for performance shall start from the date indicated in the Notice To Proceed.

I-1.06 LIQUIDATED DAMAGES:

The amount of liquidated damages, referred to in Article 4.06 of the Agreement, for completion of this project shall be \$500 per calendar day.

I-1.07 BASIS OF AWARD OF CONTRACT:

The basis of award referred to in Item I-2.11 of Instructions to Bidders shall be the greatest amount of work, which can be accomplished within the funds available as budgeted. The award may be made on the basis of the total bid, base bid, alternates(s) if any, unit bids if any, or any combination thereof deemed to be in the best interest of the City. The actual amount of an award may be adjusted to suit funds available. The City, at its option, may award to multiple bidders. The work will be completed in subsequently issued Work Orders.

Contract can be renewed for two (2) additional 1-year periods, if agreeable to both parties and if funds are available. To renew the contract for an additional 1-year period the Contractor must notify the City in writing that it desires renewal of the contract. The letter must be received by the City at least 120 days prior to contract expiration. The City will respond to the Contractor's renewal request at least 90 days prior to contract expiration.

An escalation of the Contract Unit Prices can be requested based on the following methodology. Adjustments to the unit prices shall be based on the average from the Engineering News Record (ENR) Skilled Labor Index and the Materials Cost Index. The average of these two indices at renewal will be divided by the average of these two indices at the time of the Notice to Proceed (NTP) to arrive at the escalation factor. Refer to the Cost Escalation Example on page I-1i

Unless all bids are rejected, the award will be made within 90 days after opening proposals.

I-1.08 GROUND BREAKING CEREMONY:

Arrangement may be made by the City in coordination with the Contractor, for construction to commence with a Ground Breaking Ceremony. Details will be discussed at the pre-construction conference.

I-1.09 INSURANCE:

The insurance required for this project shall be as indicated on the attached and incorporated Special Instructions pages beginning with page INS-1 entitled CITY OF TAMPA INSURANCE REQUIREMENTS, which among other things requires the Contractor to provide a Certificate of Insurance to the City prior to commencing work. The City may from time to time use a third-party vendor to manage its insurance certificates and related documentation which vendor may periodically initiate contact, requests for information, etc. on the City's behalf.

I-1.10 TESTING:

The Contractor shall perform all Quality Control (QC) testing to meet the FDOT requirements in the Florida Department of Transportation, JULY 2020 Standard Specifications for Road and Bridge Construction

INSTRUCTIONS TO BIDDERS
SECTION 1 – SPECIAL INSTRUCTIONS

I-1.10 EQUAL BUSINESS OPPORTUNITY PROGRAM (EBO) REQUIREMENTS / PROJECT SUBCONTRACTING GOAL(S)

BIDDERS MUST SUBMIT COMPLETED AND SIGNED CITY OF TAMPA FORMS MBD-10 AND MBD-20 WITH THEIR BIDS. BIDS SUBMITTED WITHOUT THESE COMPLETED FORMS (INCLUDING SIGNATURES) WILL BE DEEMED NON-RESPONSIVE. INSTRUCTIONS ON COMPLETING THE FORMS ARE INCLUDED AFTER EACH FORM IN THIS BID PACKAGE.

THE CHECKED BOX INDICATES SECTION THAT APPLIES TO THIS BID.



SUBCONTRACTING GOAL – (WMBE and SLBE)

In accordance with the City of Tampa's EBO Program, Chapter 26.5, City of Tampa Code, the subcontracting goal(s) has/have been established for subcontracting with City-certified underutilized WMBEs (Women and Minority Business Enterprises) and/or SLBEs (Small Local Business Enterprises) on this project (hereinafter "Goal"). *The Goal is based, in part, upon the availability of City-certified firms to perform the anticipated scope of work (Bid is subject to the subcontracting project goal(s) section for which a corresponding numerical percent is indicated).* Project Industry Category: Construction

- Project Goal(s): _____% **U-WMBE (Underutilized Woman and Minority Business Enterprise) (EBO Program)**
per MBD Form-70 the U-WMBE subcontract Classification for Construction is African American (BBE)
- _____% **SLBE (Small Local Business Enterprise) (EBO Program)** only City-certified SLBEs
- 20% **U-WMBE/SLBE Combined (EBO Program)**
per MBD Form-70 the U-WMBE subcontract Classification for Construction is African American (BBE)
together with City-certified SLBEs
- _____% **WMBE/SLBE ASPIRATIONAL (EBO Program)** An all-inclusive SLBE/WMBE goal; any City certified firm counts towards goal attainment.

BIDDERS MUST SOLICIT ALL COMPANIES ON THE ATTACHED AVAILABILITY CONTACT LIST at least **five (5) City business days or more prior to bid opening as a first step** to demonstrate Good Faith Efforts to achieve the Goal. Substantive documentation that demonstrates Good Faith Efforts to achieve the Goal **must be submitted with the bid**, including emails, faxes, phone calls, letters, and other communication with City-certified firms. Bidders may explore other potential opportunities for subcontracting by consulting the current directory of all certified firms posted by the City of Tampa at <https://tampa.diversitysoftware.com> as the Availability Contact List may not be inclusive of all firms that could count toward Goal attainment. However, ONLY SUBCONTRACTING with those specific WMBEs designated as "underutilized" by Classification in the appropriate industry category (and, if made applicable by being specifically included in the above Goal, SLBEs) will count toward meeting the Goal. Making Good Faith Efforts through these and other means (not pro-forma) is the responsibility of the Bidder. See the attached Good Faith Effort Compliance Plan (GFCEP) (MBD Form-50) for specific requirements.

GOOD FAITH EFFORT COMPLIANCE PLAN (GFCEP) REQUIRED (MBD FORM-50). When a Goal has been established, the Bidder **must submit** with its bid a Good Faith Effort Compliance Plan (GFCEP) using the attached MBD Form-50 together with supporting documentation as specified therein. **Submittals that do not contain MBD Form-50 when a Goal has been established will be deemed non-responsive.** Additional explanation and documentation is required whenever a City-certified subcontractor's quote is not utilized. Any additional information regarding GFCEP (post-bid) shall be only upon the City's request for clarification of information submitted with bid and not to "cure" omissions or deficiencies of the bid.

NOTE: When U-WMBEs are included in a Goal, only those City-certified subcontractors whose WMBE Classification is designated "underutilized" will count toward Goal attainment. Refer to **MBD Form-70** to identify underutilized WMBEs by subcontract Classification for the applicable project industry category. A prime bidder who is a City-certified WMBE and/or SLBE is not exempt from the **GFCEP MBD Form-50** requirements.



SUBCONTRACTING GOAL – (DBE) FDOT DISADVANTAGED BUSINESS ENTERPRISE PROGRAM

The City of Tampa is required to use the Florida Department of Transportation (FDOT) Disadvantaged Business Enterprise (DBE) program on contracts with Federal Highway Administration (FHWA) funds. Effective October 1, 2017 through to September 30, 2020, the overall FDOT DBE aspirational goal is **10.65%** and is *race neutral*, meaning that FDOT believes the aspirational DBE goal may be achieved entirely through ordinary, competitive procurement methods. Despite the absence of a contract specific DBE goal on this project, the City encourages bidders to seek out and use DBEs and other minority, small businesses. For assistance in identifying certified DBEs, FDOT offers the use of its supportive services program accessed via FDOT's Equal Opportunity Office at <http://www.fdot.gov/equalopportunity/serviceproviders.shtm>. FDOT DBE rules and regulations apply to this solicitation, including the requirement to report bidder opportunity information in the FDOT Equal Opportunity Compliance (EOC) web-based application within three (3) business days of submission of the bid for ALL subcontractors who quoted bidder for this specific project. The five (5) char/digit LAP Agreement Contract Number for this project is G _____. The web address to the EOC system is: <https://fdotwp1.dot.state.fl.us/EqualOpportunityCompliance/Account.aspx/LogIn?ReturnUrl=%2fEqualOpportunityCompliance>

NOTE: Regardless of FDOT DBE program applicability, for data collection purposes bidder still **must submit** City Forms MBD-10 and MBD-20 completed and signed with its bid or the bid will be deemed non-responsive.

DIVERSITY MANAGEMENT INITIATIVE (DMI) DATA REPORTING FORMS REQUIRED FOR ALL CONTRACTS

Bidder **must submit**, with its bid, completed and signed Forms MBD-10 and MBD-20 to be considered a responsive bid. Specifically, the 'Schedule of All Solicited Sub-(Contractors/Consultants/Suppliers) (Form MBD-10)' listing all subcontractors (including non-certified) solicited and 'Schedule of All -To Be Utilized Sub-(Contractors/Consultants/Suppliers) (Form MBD-20)' listing all subcontractors (including non-certified) to be utilized. Supplemental forms, such as 'Form MBD-40 Official Letter Of Intent' (LOI), can be submitted with the bid or once declared lowest-responsive bidder. After an award, 'DMI Sub-(Contractors/Consultants/Suppliers) Payment Form (Form MBD-30)' is to be submitted with payment requests to report payments to subcontractors and using the on-line automated MBD compliance software system available at <https://tampa.diversitysoftware.com>

For additional information about the WMBE and SLBE programs contact the Minority and Small Business Development Office at 813-274-5522. (3-18)

INSTRUCTIONS TO BIDDERS
SECTION 1 - SPECIAL INSTRUCTIONS

I-1.11 BID SECURITY:

Surety companies shall have a rating of not less than B+ Class VI as evaluated in the most recently circulated Best KeyRating Guide Property/Casualty.

I-1.12 PUBLIC CONSTRUCTION BOND:

The Bidder who is awarded the Contract will be required to furnish a Public Construction Bond upon the form provided herein, equal to 100 percent of the Contract price, such Bond to be issued and executed by (a) surety company(ies) acceptable to the City and licensed to underwrite contracts in the State of Florida. After execution of the Agreement and before commencing work, the Contractor must provide the City a certified copy of the officially recorded Bond.

I-1.13 AGREEMENT

SECTION 2 – POWERS OF THE CITY’S REPRESENTATIVES, new Article 2.05:

Add the following:

Article 2.05 CITY’S TERMINATION FOR CONVENIENCE:

The City may, at any time, terminate the Contract in whole or in part for the City’s convenience and without cause. Termination by the City under this Article shall be by a notice of termination delivered to the Contractor, specify the extent of termination and the effective date.

Upon receipt of a notice of termination, the Contractor shall immediately, in accordance with instructions from the City, proceed with performance of the following duties regardless of delay in determining or adjusting amounts due under this Paragraph:

- (a) cease operations as specified in the notice;
- (b) place no further orders and enter into no further subcontracts for materials, labor, services or facilities except as necessary to complete continued portions of the Contract;
- (c) terminate all subcontracts and orders to the extent they relate to the Work terminated;
- (d) proceed to complete the performance of Work not terminated; and
- (e) take actions that may be necessary, or that the City may direct, for the protection and preservation of the terminated Work.

The amount to be paid to the Contractor by the City because of the termination shall consist of:

- (a) for costs related to work performed on the terminated portion of the Work prior to the effective date including termination costs relative to subcontracts that are properly chargeable to the terminated portion of the Work;
- (b) the reasonable costs of settlement of the Work terminated, including accounting, legal, clerical and other expenses reasonable necessary for the preparation of termination settlement proposals and supporting data; additional costs of termination and settlement of subcontracts excluding amounts of such settlements; and storage, transportation, and other costs incurred which are reasonably necessary for the preservation, protection or disposition of the terminated Work; and
- (c) a fair and reasonable profit on the completed Work unless the Contractor would have sustained a loss on the entire Contract had it been completed.

Allowance shall be made for payments previously made to the Contractor for the terminated portion of the Work, and claims which the City has against the Contractor under the Contract, and for the value of materials supplies, equipment or other items that are part of the costs of the Work to be disposed of by the Contractor.

SECTION 5 – SUBCONTRACTS AND ASSIGNMENTS, Article 5.01, Page A-7, last paragraph:

Change “...twenty-five (25) percent...” to “...fifty-one (51) percent...”

SECTION 8 – CONTRACTOR’S EMPLOYEES, Article 8.03, Page A-9, delete Article 8.03 in its entirety and

Replace with the following new article:

ARTICLE 8.03 EMPLOYMENT OPPORTUNITIES

The Contractor shall, in the performance of the work required to be done under this Contract, employ all workers without discrimination and must not maintain, provide or permit facilities that are segregated.

INSTRUCTIONS TO BIDDERS
SECTION 1 - SPECIAL INSTRUCTIONS

SECTION 10 – PAYMENTS, Article 10.05, Page A-10, 1st Paragraph, 1st Sentence:
Change "...fair value of the work done, and may apply for..." to "...fair value of the work done, and shall apply for..."

SECTION 10 – PAYMENTS, Article 10.05, Page A-10, 1st Paragraph, 1st Sentence:
Change "...fair value of the work done, and may apply for..." to "...fair value of the work done, and shall apply for..." Note: Retainage as referenced in Article 10.05 is limited to a maximum of five percent (5%).

SECTION 11 – MISCELLANEOUS PROVISIONS, Article 11.02, Page A-12, 1st Paragraph, 2nd Sentence:
Delete the 2nd Sentence in its entirety and replace it with the following new 2nd Sentence:

Without limiting application of Article 11.07, below, whenever the Contractor is required or desires to use any design, device, material, or process covered by letters of patent or copyright, the Contractor shall indemnify, defend, and hold harmless the City Indemnified Parties (as defined below) from any and all Claims (as defined below) for infringement by reason of the use of any such patented design, device, tool, material, equipment, or process, to be performed under the Contract and damages which may be incurred by reason of such infringement at any time during the prosecution or after completion of the work.

SECTION 11 – MISCELLANEOUS PROVISIONS, Article 11.03, Page A-12:
Delete Article 11.03 in its entirety and replace with the following new article:
ARTICLE 11.03 INTENTIONALLY OMITTED.

SECTION 11 – MISCELLANEOUS PROVISIONS, Article 11.07, Page A-12:
Delete Article 11.07 in its entirety and replace with the following new article:
ARTICLE 11.07 INDEMNIFICATION PROVISIONS

Whenever there appears in this Agreement, or in the other Contract Documents made a part hereof, an indemnification provision within the purview of Chapter 725.06, Laws of Florida, the monetary limitation on the extent of the indemnification under each such provision shall be One Million Dollars or a sum equal to the total Contract price, whichever shall be the greater.

Contractor releases and agrees to defend, indemnify and hold harmless the City, its officers, elected and appointed officials, employees, and/or agents (collectively, "City Indemnified Parties") from and against any and all losses, liabilities, damages, penalties, settlements, judgments, charges, or costs (including without limitation attorneys' fees, professional fees, or other expenses) of every kind and character arising out of any and all claims, liens, is entitled to indemnification hereunder. This obligation shall in no way be limited in any nature whatsoever by any limitation on the amount or type of Contractor's insurance coverage.

The parties agree that to the extent the written terms of this indemnification are deemed by a court of competent jurisdiction to be in conflict with any provisions of Florida law, in particular Sections 725.06 and 725.08, Florida Statutes, the written terms of this indemnification shall be deemed by any court of competent jurisdiction to be modified in such a manner as to be in fully and complete compliance with all such laws and to contain such limiting conditions or limitations of liability, or to not contain any unenforceable or prohibited term or terms, such that this indemnification shall be enforceable in accordance with and to the maximum extent permitted by Florida law.

The obligation of Contractor under this Article is absolute and unconditional; it is not conditioned in any way on any attempt by a City Indemnified Party to collect from an insurer any amount under a liability insurance policy, and is not subject to any set-off, defense, deduction, or counterclaim that the Contractor might have against the City Indemnified Party. The duty to defend hereunder is independent and separate from the duty to indemnify, and the duty to defend exists regardless of any ultimate liability of Contractor, the City, and any City Indemnified Party. The duty to defend arises immediately upon presentation of a Claim by any party and written notice of such Claim being provided to Contractor. Contractor's defense and indemnity obligations hereunder will survive the expiration or earlier termination of this Contract.

INSTRUCTIONS TO BIDDERS
SECTION 1 - SPECIAL INSTRUCTIONS

Contractor agrees and recognizes that the City Indemnified Parties shall not be held liable or responsible for any Claims which may result from any actions or omissions of Contractor in which the City Indemnified Parties participated either through providing data or advice and/or review or concurrence of Contractor's actions. In reviewing, approving or rejecting any submissions by Contractor or other acts of Contractor, the City in no way assumes or shares any responsibility or liability of Contractor or any tier of subcontractor/subconsultant/supplier, under this Contract.

In the event the law is construed to require a specific consideration for such indemnification, the parties agree that the sum of Ten Dollars and 00/100 (\$10.00), receipt of which is hereby acknowledged, is the specific consideration for such indemnification and the providing of such indemnification is deemed to be part of the specifications with respect to the services provided by Contractor.

SECTION 11 – MISCELLANEOUS PROVISIONS, Article 11.12, Page A-13:
Change Article 11.12 to add the following new language after existing text:

The City of Tampa is a public agency subject to Chapter 119, Florida Statutes. In accordance with Florida Statutes, 119.0701, Contractor agrees to comply with Florida's Public Records Law, including the following:

1. Contractor shall keep and maintain public records required by the City to perform the services under this Agreement;
2. Upon request by the City, provide the City with copies of the requested records, having redacted records in total on in part that are exempt from disclosure by law or allow the records to be inspected or copied within a reasonable time (with provision of a copy of such records to the City) on the same terms and conditions that the City would provide the records and at a cost that does not exceed that provided in Chapter 119, Florida Statutes, or as otherwise provided by law;
3. Ensure that records, in part or in total, that are exempt or that are confidential and exempt from disclosure requirements are not disclosed except as authorized by law for the duration of the Agreement term and following completion (or earlier termination) of the Agreement if Contractor does not transfer the records to the City;
4. Upon completion (or earlier termination) of the Agreement, Contractor shall within 30 days after such event either transfer to the City, at no cost, all public records in possession of the Contractor or keep and maintain the public records in compliance with Chapter 119, Florida Statutes. If Contractor transfers all public records to the City upon completion (or earlier termination) of the Agreement, Contractor shall destroy any duplicate records that are exempt or confidential and exempt from public records disclosure requirements. If Contractor keeps and maintains public records upon completion (or earlier termination) of the Agreement, Contractor shall meet all applicable requirements for retaining public records. All records stored electronically must be provided to the City in a format that is compatible with the information technology systems of the agency.

The failure of Contractor to comply with Chapter 119, Florida Statutes, and/or the provisions set forth in this Article shall be grounds for immediate unilateral termination of the Agreement by the City; the City shall also have the option to withhold compensation due Contractor until records are received as provided herein.

IF CONTRACTOR HAS QUESTIONS REGARDING THE APPLICATION OF CHAPTER 119, FLORIDA STATUTES, TO CONTRACTOR'S DUTY TO PROVIDE PUBLIC RECORDS RELATING TO THIS AGREEMENT, CONTACT THE CUSTODIAN OF PUBLIC RECORDS AT 813-274-8598, JIM.GREINER@TAMPAGOV.NET, AND CONTRACT ADMINISTRATION DEPARTMENT, TAMPA MUNICIPAL OFFICE BUILDING, 4TH FLOOR, 306 E. JACKSON ST. TAMPA, FLORIDA 33602.

INSTRUCTIONS TO BIDDERS
SECTION 1 - SPECIAL INSTRUCTIONS

I-1.14 Contractors must utilize the U.S. Department of Homeland Security's E-Verify Systems to verify the employment eligibility of all persons employed during the term of the Contract to perform employment duties within the State of Florida and all persons, including subcontractors, assigned by Contractor to perform work pursuant to the contract.

E-Verify. In accordance with Section 448.095, Florida Statutes, the Contractor agrees to register with and utilize the U.S. Department of Homeland Security's E-Verify system to verify the employment eligibility of all new employees hired during the term of the Contract for the services specified in the Contract. The Contractor must also include a requirement in subcontracts that the subcontractor must register with and utilize the E-Verify system to verify the employment eligibility of all new employees hired by the subcontractor during the Contract term. If the Contractor enters into a contract with a subcontractor, the subcontractor must provide the Contractor with an affidavit stating that the subcontractor does not employ, contract with, or subcontract with an unauthorized alien. The Contractor shall maintain a copy of such affidavit for the duration of the Contract. If the City has a good faith belief that the Contractor has knowingly violated Section 448.09(1), Florida Statutes, the City shall terminate the Contract with the Contractor, and the Contractor may not be awarded a contract with the City for at least 1 year after the date on which the Contract was terminated. The Contractor is liable for any additional costs incurred by the City as a result of the termination of the Contract. If the City has a good faith belief that a subcontractor knowingly violated the law, but the Contractor has otherwise complied with the law, the City shall promptly notify the Contractor and order the Contractor to immediately terminate the contract with the subcontractor.

I-1.15 GENERAL PROVISIONS; G-2.02 Copies Furnished to Contractor: Replace the first paragraph with the following:

The Contractor shall acquire for its use copies of the plans and specifications as needed, which may be downloaded from the City's web site, at <http://www.tampagov.net/contract-administration/programs/construction-project-bidding>.

Bidder as part of the solicitation process (and as Contractor if Bidder is successful) may hold, come into possession of, and/or generate certain building plans, blueprints, schematic drawings, including draft, preliminary, and final formats, which depict the internal layout and structural elements of a building, facility, or other structure owned or operated by the City or an agency (singularly or collectively "Exempt Plans"), which pursuant to Section 119.071(3), Florida Statutes, are exempt from Section 119.07(1), Florida Statutes and Section 24(a), Art. I of the Florida State Constitution. Contractor certifies it has read and is familiar the exemptions and obligations of Section 119.071(3), Florida Statutes; further that Contractor is and shall remain in compliance with same, including without limitation maintaining the exempt status of such Exempt Plans, for so long as any Exempt Plans are held by or otherwise in its possession.

I-1.16 PAYMENT DISPUTE RESOLUTION

Any dispute pertaining to pay requests must be presented to the City pursuant to Executive Order 2003-1.

I-1.17 SCRUTINIZED COMPANIES CERTIFICATION

Section 287.135, Florida Statutes, prohibits agencies or local governmental entities from contracting for goods or services of any amount with companies that are on the Scrutinized Companies that Boycott Israel List or are engaged in a boycott of Israel, and of \$1 million or more with companies that are on either the Scrutinized Companies with Activities in Sudan List or the Scrutinized Companies with Activities in the Iran Petroleum Energy Sector List, or are engaged in business operations in Cuba or Syria. Specifically, Section 287.135(2), Florida Statutes, states: "A company is ineligible to, and may not, bid on, submit a proposal for, or enter into or renew a contract with an agency or local governmental entity for goods or services of: (a) Any amount if, at the time of bidding on, submitting a proposal for, or entering into or renewing such contract, the company is on the Scrutinized Companies that Boycott Israel List, created pursuant to s. 215.4725, or is engaged in a boycott of Israel; or (b) One

INSTRUCTIONS TO BIDDERS
SECTION 1 - SPECIAL INSTRUCTIONS

million dollars or more if, at the time of bidding on, submitting a proposal for, or entering into or renewing such contract, the company: 1. Is on the Scrutinized Companies with Activities in Sudan List or the Scrutinized Companies with Activities in the Iran Petroleum Energy Sector List, created pursuant to s. 215.473; or 2. Is engaged in business operations in Cuba or Syria.”

Upon submitting its bid or proposal, a bidder/proposer: (i) certifies the company is not in violation of Section 287.135, Florida Statutes, and shall not be in violation at the time the company enters into or renews any resulting contract; and (ii) agrees any such resulting contract shall be deemed to contain a provision that allows the City, at its option, to terminate such contract for cause if the company is found to have submitted a false certification, been placed on one or any of the foregoing Lists, been engaged in a boycott of Israel, or been engaged in business operations in Cuba or Syria.

I-1.18 FLORIDA'S PUBLIC RECORDS LAW; DATA COLLECTION

Pursuant to Section 119.071(5)(a)2a, Florida Statutes, social security numbers shall only be collected from Bidders and/or Contractor by the City should such number be needed for identification, verification, and/or tax reporting purposes. To the extent Bidder and/or Contractor collects an individual's social security number in the course of acting on behalf of the City pursuant to the terms and conditions of its Proposal or, if awarded, the Agreement, Bidder and/or Contractor shall follow the requirements of Florida's Public Records Law.

I-1.19 APPRENTICESHIP REQUIREMENTS AND REPORTING FORM

Bidders shall comply with the conditions of the Apprenticeship Requirements and Reporting Form, Ordinance No. 2021-33, incorporated into the Contract and as specified therein.

Cost Escalation Example

I-1.07.1 Cost Escalation:

The cost escalation factor will be applied only as part of the renewal **CONTRACT**.

The method for adjusting the unit price of each Bid Proposal item uses construction economic information regularly published in ENR (Engineering News-Record). Each Bid Proposal item unit cost is multiplied by the cost escalation factor (CEF) which is calculated as follows:

| | | | |
|--|---|--|----------------------|
| CEF = | <table border="1" style="width: 100%; border-collapse: collapse;"> <tr> <td style="text-align: center; padding: 5px;">Average index at renewal time (x-months) after NTP</td> </tr> <tr> <td style="text-align: center; padding: 5px;">Average index at NTP</td> </tr> </table> | Average index at renewal time (x-months) after NTP | Average index at NTP |
| Average index at renewal time (x-months) after NTP | | | |
| Average index at NTP | | | |

where,

| | | | |
|--|--|--|---|
| Average index = | <table border="1" style="width: 100%; border-collapse: collapse;"> <tr> <td style="text-align: center; padding: 5px;">Skilled Labor Index + Materials Cost Index</td> </tr> <tr> <td style="text-align: center; padding: 5px;">2</td> </tr> </table> | Skilled Labor Index + Materials Cost Index | 2 |
| Skilled Labor Index + Materials Cost Index | | | |
| 2 | | | |

Example:

NTP issued September 15, 2022

| | | | | |
|------------------------|--|--------------------|---|-----------|
| Average index at NTP = | <table border="1" style="width: 100%; border-collapse: collapse;"> <tr> <td style="text-align: center; padding: 5px;">10410.99 + 3391.88</td> </tr> <tr> <td style="text-align: center; padding: 5px;">2</td> </tr> </table> | 10410.99 + 3391.88 | 2 | = 6901.44 |
| 10410.99 + 3391.88 | | | | |
| 2 | | | | |

| | | | | |
|------------------------------------|--|--------------------|---|-----------|
| Average index 9 months after NTP = | <table border="1" style="width: 100%; border-collapse: collapse;"> <tr> <td style="text-align: center; padding: 5px;">10690.14 + 3586.31</td> </tr> <tr> <td style="text-align: center; padding: 5px;">2</td> </tr> </table> | 10690.14 + 3586.31 | 2 | = 7138.23 |
| 10690.14 + 3586.31 | | | | |
| 2 | | | | |

| | | | | |
|---------|---|---------|---------|--------|
| CEF = | <table border="1" style="width: 100%; border-collapse: collapse;"> <tr> <td style="text-align: center; padding: 5px;">7138.23</td> </tr> <tr> <td style="text-align: center; padding: 5px;">6901.44</td> </tr> </table> | 7138.23 | 6901.44 | = 1.03 |
| 7138.23 | | | | |
| 6901.44 | | | | |

Note: Nine months is used as an example only. The date used for the formula will be the contract renewal date.

If the value of the CEF is less than or equal to one (rounded to the nearest 1/100th), the line-item prices will remain the same. If the value of the CEF is greater than 1.00, the Bid proposal line-item prices will be multiplied by the new adjusted CEF. The cost adjustment will take effect at the beginning of the **CONTRACT** renewal period.

In no event shall the escalation exceed 5% percent in any one contract term.

INSTRUCTIONS TO BIDDERS

SECTION 2 GENERAL INSTRUCTIONS

I-2.01 BIDDER'S RESPONSIBILITY

Before submitting Proposals, Bidders shall carefully examine the entire site of the proposed work and adjacent premises and the various means of approach and access to the site, and make all necessary investigations to inform themselves thoroughly as to the facilities necessary for delivering, placing and operating the necessary construction equipment, and for delivering and handling materials at the site, and inform themselves thoroughly as to all difficulties involved in the completion of all the work in accordance with the Contract Documents.

Bidders must examine the Plans, Specifications, and other Contract Documents and shall exercise their own judgment as to the nature and amount of the whole of the work to be done, and for the bid prices must assume all risk of variance, by whomsoever made, in any computation or statement of amounts or quantities necessary to complete the work in strict compliance with the Contract Documents.

Elevations of the ground are shown on the Plans and are believed to be reasonably correct, but are not guaranteed to be absolutely so and are presented only as an approximation. Bidders shall satisfy themselves as to the correctness of all elevations.

The City may have acquired, for its own use, certain information relating to the character of materials, earth formations, probable profiles of the ground, conditions below ground, and water surfaces to be encountered at the site of the proposed work. This information, if it exists, is on file at the offices of the Department of Public Works and Bidders will be permitted to see and examine this information for whatever value they consider it worth. However, this information is not guaranteed, and Bidders should satisfy themselves by making borings or test pits, or by such other methods as they may prefer, as to the character, location, and amounts of water, peat, clay, sand, quicksand, gravel, boulders, conglomerate, rock, gas or other material to be encountered or work to be performed.

Various underground and overhead structures and utilities are shown on the plans. The location and dimensions of such structures and utilities, where given, are believed to be reasonably correct, but do not purport to be absolutely so. These structures and utilities are plotted on the Plans for the information of the Bidders, but information so given is not to be construed as a representation or assurance that such structures will be found or encountered as plotted, or that such information is complete or accurate.

I-2.02 FORM, PREPARATION AND PRESENTATION OF PROPOSALS

Each Proposal shall be submitted upon the Proposal Form and in accordance with the instructions included herein. The Proposal Form must not be detached herefrom. All blank spaces for bid prices must be filled in, in both words and figures, with the unit or lump sum prices, or both, for which the Proposal is made. The computed total price for each unit price Contract Item shall be determined by multiplying the estimated quantity of the item, as set forth in the Proposal Form, by the corresponding unit price bid for such item. The resulting product shall be entered in the appropriate blank space under the column headed "Computed Total Price for Item". The lump sum price bid for each lump sum price Contract Item shall also be entered in the column headed "Computed Total Price for Item". If a Proposal contains any omissions, erasures, alterations, additions, or items not called for in the itemized Proposal, or contains irregularities of any kind, such may constitute sufficient cause for rejection of the Proposal. In case of any discrepancy in the unit price or amount bid for any item in the Proposal, the price as expressed in written words will govern. In no case is the Agreement Form to be filled out or signed by the Bidder.

In the case of certain jobs bid Lump Sum a "Schedule of Unit Prices" must be filled out as an attachment to the Lump Sum proposal. These prices may be used as a guide for the negotiation of change orders, at the City's option.

The proposal must be signed and certified and be presented on the prescribed form in a sealed envelope on/or before the time and at the place stated in the Notice of Bidders, endorsed with the name of the person, firm or corporation presenting it, the date of presentation, and the title of the work for which the Proposal is made.

Unless the apparent low bidder is now engaged in or has recently completed contract work for the City of Tampa, he, if requested, shall furnish to the City, after the opening of bids and prior to award, a summary statement of record of construction experience over the past three (3) years with proper supporting evidence, and, if required by the City, shall also furnish a list of equipment and other facilities pertinent to and available for the proper execution of the proposed work, and a statement of financial resources to the extent necessary to establish ability to carry on the proposed work. The City may make further investigations as considered necessary with respect to responsibility of the Bidder to whom it appears may be awarded the Contract.

If forwarded by mail, the sealed envelope containing the Proposal, endorsed as directed above, must be enclosed in another envelope addressed as specified in the Notice to Bidders and sent by registered mail.

I-2.03 ADDENDA AND INTERPRETATIONS

No interpretation of the meaning of the Plans, Specifications, or other Contract Documents will be made to any Bidder orally.

Every request for such interpretation must be in writing, addressed to the Contract Administration Department, Tampa Municipal Office Building, 4th Floor North, City Hall Plaza, Tampa, Florida 33602. To be given consideration, such request must be received at least seven (7) days prior to the date fixed for the opening of the Proposals. Any and all such interpretations and any supplemental instructions will be in the form of written addenda which, if issued, will be sent by certified mail, with return receipt requested, to all prospective bidders at the respective addresses furnished, for such purposes, not later than three (3) working days prior to the date fixed for the opening of the Proposals, and if requested, a copy will be delivered to the prospective bidder's representative. Failure of any Bidder to receive any such addenda shall not relieve said Bidder from any obligation under his Proposal as submitted. All addenda so issued shall become part of the Contract Documents.

I-2.04 BID SECURITY

Each Proposal must be accompanied by a certified or cashier's check issued by a solvent bank or trust company and payable at sight to the City of Tampa, in compliance with Section 255.051 Florida Statutes, or a Bid Bond upon the form provided herein, in an amount of not less than five percent of the sum of the computed total amount of the Bidder's Proposal as a guarantee that if the Proposal is accepted, the Bidder will execute and fill in the proposed Contract and Public Construction Bond within twenty (20) days after notice of award of the Contract. Certified checks shall have all necessary documentary revenue stamps attached if required by law. Surety on Bid Bonds shall be a duly authorized surety company authorized to do business in the State of Florida, and all such Bonds shall be issued or countersigned by a local resident producing agent, and satisfactory evidence of the authority of the person or persons executing such Bond to Execute the same shall be submitted with the Bond. Bid Bonds shall be issued by a surety company acceptable to the City.

Within ten (10) days after the opening of Proposals, the bid security of all but the three lowest Bidders will be returned. The bid security of the remaining two Bidders whose Proposals are not accepted will be

returned within ten (10) days after the execution of the Contract, or, if no such Contract has been executed, within ninety (90) days after the date of opening Proposals. The bid security of the Bidder whose Proposal is accepted will be returned only after he has duly executed the Contract and furnished the required Public Construction Bond and insurance.

Should it be necessary for the City to retain the bid security and said bid security is in the form of checks, the checks of these Bidders will be returned if replaced by Bid Bonds in an amount equal to the amount of the checks of such Bidders in such form and issued by a surety company acceptable to the City.

A Bidder may withdraw his Proposal before the time fixed for the opening of Proposals, without prejudice to himself, by communicating his purpose, in writing, to the Mayor and City Council, and when his communication is received, the Proposal will be handed to him or his authorized agent unopened. No Bidder may withdraw his Proposal within ninety (90) days after the day of opening Proposals.

The Bidder whose Proposal is accepted shall enter into a written contract, upon the Agreement form included herein, for the performance of the work and furnish the required Public Construction Bond within twenty (20) days after written notice by the City of Award of Contract has been served on such Bidder personally or after receipt of the written notice by registered mail to such Bidder at the address given in his Proposal.

If the Bidder to whom a Contract is awarded refuses or neglects to execute it or fails to furnish the required Public Construction Bond within twenty (20) days after receipt by him of the Notice of Award of Contract, the amount of his bid security shall be forfeited and shall be retained by the City as liquidated damages, and not as a penalty, it being now agreed that said sum is a fair estimate of the amount of damages that the City will sustain in case said Bidder fails to enter into a Contract and furnish the required Public Construction Bond. If a Bid Bond was furnished, the full amount of the Bond shall become due and payable as liquidated damages caused by such failure. The full amount of the bid security shall be forfeited as liquidated damages without consideration of the fact that an award may be less than the full amount of the Bidder's Proposal, excepting that the award shall be within the conditions of said Proposal relating to the basis of consideration for an award. No plea of mistake in the bid or misunderstanding of the conditions of forfeiture shall be available to the Bidder for the recovery of his deposit or as a defense to any action based upon the neglect or refusal to execute a contract.

I-2.05 LAWS AND REGULATIONS

The Bidder who is awarded the Contract must comply with all laws of the State of Florida, and all applicable Ordinances of the City of Tampa respecting labor and compensation and with all other statutes, ordinances, rules and regulations applicable and having the force of law.

I-2.06 PUBLIC CONSTRUCTION BOND

The Bidder who is awarded the Contract will be required to furnish a Public Construction Bond upon the form provided herein, equal to 100 percent of the Contract price, such Bond to be executed by a surety company acceptable to the City of Tampa and licensed to underwrite contracts in the State of Florida. Surety companies shall have a rating of not less than: B+ Class VI as evaluated in the most recently circulated BEST'S KEY RATING GUIDE PROPERTY-LIABILITY.

I-2.07 SIGNATURE AND QUALIFICATIONS OF BIDDERS

Proposals must be signed in ink by the Bidder with signature in full. When a firm is a Bidder, the Proposal shall be signed in the name of the firm by one or more of the partners. When a corporation is a Bidder the officer signing shall set out the corporate name in full beneath which he shall sign his name and give the title of his office. The Proposal shall also bear the seal of the corporation attested by its secretary. Anyone signing the Proposal as agent must file with it legal evidence of his authority to do so.

Bidders who are nonresident corporations shall furnish to the City a

duly certified copy of their permit to transact business in the State of Florida, signed by the Secretary of State, within ten days of the notice to do so. Such notice will be given to Bidders who are nonresident corporations, to whom it appears an award will be made, and the copy of the permit must be filed with the City before the award will be made. Failure to promptly submit this evidence of qualification to do business in the State of Florida may be basis for rejection of the Proposal.

I-2.08 REJECTION OF PROPOSALS

The City reserves the right to reject any Proposal if investigation of the Bidder fails to satisfy the City that such Bidder is properly qualified to carry out the obligations and to complete the work contemplated therein. Any or all Proposals will be rejected if there is reason to believe that collusion exists among Bidders. Proposals will be considered irregular and may be rejected if they show serious omissions, alterations in form, additions not called for, conditions or unauthorized alternates, or irregularities of any kind. The City reserves the right to reject any or all Proposals and to waive such technical errors as may be deemed best for the interests of the City.

I-2.09 QUANTITIES ESTIMATED ONLY

The estimate of quantities of the various items of work and materials, if set forth in the Proposal Form, is approximate only and is given solely to be used as a uniform basis for the comparison of Proposals.

The quantities actually required to complete the Contract work may be less or more than so estimated, and if awarded a Contract for the work specified, the Contractor agrees that he will not make any claim for damages or for loss of profits because of a difference between the quantities of the various classes of work assumed for comparison of Proposals and quantities of work actually performed. The City further reserves the right to vary the quantities in any amount.

I-2.10 COMPARISON OF PROPOSALS

Except jobs bid on a "One Lump Sum" basis, proposals will be compared on the basis of a total computed price arrived at by taking the sum of the estimated quantity of each item and the corresponding unit price of each item, and including any lump sum prices on individual items.

The computed total prices for individual Contract Items and the total computed price for the entire Contract, as entered by the Bidder in the Proposal Form, are for convenience only and are subject to correction in the tabulation and computation of the Proposals.

I-2.11 BASIS OF AWARD

The Contract will be awarded, if at all, to the lowest responsible Bidder or Bidders, as determined by the City and by the terms and conditions of the Contract Documents. Unless all bids are rejected, the award will be made within ninety (90) days after the opening of Proposals. The successful Bidder will be required to possess, or obtain, a valid City Occupational License.

I-2.12 INSURANCE REQUIRED

The successful Bidder and his subcontractors will be required to procure and pay for insurance covering the work in accordance with the provisions of Article 6.02 of the Agreement as indicated on special instructions pages beginning with INS-1.

I-2.13 NO ASSIGNMENT OF BID

No Bidder shall assign his bid or any rights thereunder.

I-2.14 NONDISCRIMINATION IN EMPLOYMENT

Contracts for work under this Proposal will obligate the contractors and subcontractors not to discriminate in employment practices.

Bidders must, if requested, submit with their initial bid a signed statement as to whether they have previously performed work subject to the President's Executive Order Nos. 11246 and 11375.

Bidders must, if requested, submit a compliance report concerning their employment practices and policies in order to maintain their eligibility to receive the award of the Contract.

Successful Bidders must, if requested, submit a list of all subcontractors who will perform work on the project and written,

signed statement from authorized agents of the labor pools with which they will or may deal for employees on the work together with supporting information to the effect that said labor pools practices and policies are in conformity with Executive Order No. 11246 and that said labor pools will affirmatively cooperate in or offer no hindrance to the recruitment, employment and equal treatment of employees seeking employment and performing work under the Contract, or a certification as to what efforts have been made to secure such statements when such agents or labor pools have failed or refused to furnish them prior to the award of the Contract.

I-2.15 LABOR STANDARDS

The Bidder's attention is directed to the Contract Provisions of the Labor Standards for federally assisted projects which may be attached to and made a part of the Agreement.

I-2.16 NOTICE TO LABOR UNIONS

If applicable, the successful Bidder will be required to provide Labor Unions and other organizations of workers a completed copy of the form entitled "Notice to Labor Unions or Other Organizations of Workers", and such form may be made a part of the Agreement.

I-2.17 NOTICE TO PROSPECTIVE FEDERALLY-ASSISTED CONSTRUCTION CONTRACTORS

A Certification of Nonsegregated Facilities, as required by the May 9, 1967, Order (32 F.R. 7439, May 19, 1967) on Elimination of Segregated Facilities, by the Secretary of Labor, must be submitted to said Secretary prior to the award of a federally-assisted construction and Contract exceeding \$10,000 which is not exempt from the provisions of the Equal Opportunity Clause. The form of certification may be bound herein following the form of Bid Bond.

Contractors receiving federally-assisted construction Contract awards exceeding \$10,000 which are not exempt from the provisions of the Equal Opportunity Clause will be required to provide for the forwarding of the following notice to prospective subcontractor for supplies and construction contracts where the subcontracts exceed \$10,000 and are not exempt from the provisions of the Equal Opportunity Clause:

NOTICE TO PROSPECTIVE SUBCONTRACTORS OF REQUIREMENT FOR CERTIFICATIONS OF NONSEGREGATED FACILITIES

"A Certification of Nonsegregated Facilities, as required by the May 9, 1967, Order (32 F.R. 7439, May 19, 1967) on Elimination of Segregated Facilities, by the Secretary of Labor, must be submitted prior to the award of a subcontract exceeding \$10,000 which is not exempt from the provisions of the Equal Opportunity Clause."

"Contractors receiving subcontract awards exceeding \$10,000 which are not exempt from the provisions of the Equal Opportunity Clause will be required to provide from the forwarding of this notice to prospective subcontractors for supplies and construction contracts where the subcontracts exceed \$10,000 and are not exempt from the provisions of the Equal Opportunity Clause."

The United States requires a pre-award conference if a proposed construction contract exceeds one million dollars to determine if the the prospective contractor is in compliance with the Equal Employment Opportunity requirements of Executive Order 11246 of September 24, 1965. In such instances, a meeting may be scheduled at which the prospective contractor must specify what affirmative action he has taken or proposed to take to assure equal employment opportunity which must be approved by the United States before award of the contract will be authorized.

Bidders must be prepared to submit an Equal Employment Opportunity (EEO) plan at a pre-award conference. The plan must include bidding opportunities offered by the Bidder to minority subcontractors.

On October 13, 1971, President Nixon issued Executive Order 11246 emphasizing the government's commitment to the promotion of minority business enterprise. Accordingly, the United States is firmly

committed to the utilization of available resources to support this important program. U.S. agencies are most interested in realizing minority participation on the subject. Achieving equal employment opportunity compliance is required through Executive Order 11246. WE cannot emphasize too strongly that minority subcontractors be extended subcontractors bidding opportunities as but one step in your affirmative action policy.

Due to the importance of this contract, U.S. Agencies may conduct an EEO Conference prior to the award of the Contract. It is suggested that the responsive Bidder confirm the minority subcontractors he contacted for bids or quotations in his EEO plan submitted at the conference.

I-2.18 EEO AFFIRMATIVE ACTION REQUIREMENTS

By the submission of a Proposal, each Bidder acknowledges that he understands and will agree to be bound by the equal opportunity requirements of Federal regulations which shall be applicable throughout the performance of work under any contract awarded pursuant to solicitation. Each Bidder agrees that if awarded a contract, he will similarly bind contractually each subcontractor. In policies, each Bidder further understands and agrees that if awarded a contract, he must engage in Affirmative Action directed to promoting and ensuring equal employment opportunity in the work force used under the contract (and he must require contractually the same effort of all subcontractors whose subcontracts exceed \$100,000). The Bidder understands and agrees that "Affirmative Action" as used herein shall constitute a good faith effort to achieve and maintain minority employment in each trade in the on-site work force used on the project. ***** END of SECTION *****

Apprenticeship Requirements

ORDINANCE NO. 2021- 33

1
2
3
4
5
6
7
8
9
10
11
12
13
14
15
16
17
18
19
20
21
22
23
24
25
26
27
28
29
30
31
32
33
34
35
36
37
38
39
40
41
42
43
44

AN ORDINANCE OF THE CITY OF TAMPA, FLORIDA, AMENDING CITY OF TAMPA CODE OF ORDINANCES CHAPTER 26.5 TO ADD "ARTICLE IV. APPRENTICE REQUIREMENTS IN CITY CONSTRUCTION CONTRACTS"; SECTIONS 26.5-211 THROUGH 26.5-216; TO ESTABLISH REQUIREMENTS PERTAINING TO THE USE OF APPRENTICE LABOR IN CERTAIN CITY OF TAMPA CONSTRUCTION PROJECTS, TO INCLUDE SPECIFIC EXCEPTIONS THERETO; TO PROVIDE CONDITIONS RELATING TO DOCUMENTATION, INCENTIVE FOR COMPLIANCE, FEE FOR NONCOMPLIANCE AND OTHER REMEDIES, IMPLEMENTATION, EXPANSION OF SCOPE AND REPORTING; REPEALING ALL ORDINANCES OR PARTS OF ORDINANCES IN CONFLICT THEREWITH; PROVIDING FOR SEVERABILITY; PROVIDING AN EFFECTIVE DATE.

WHEREAS, construction contractors in the City of Tampa have identified a shortage of skilled labor for construction projects and a need to train younger workers as the existing job force ages; and

WHEREAS, this shortage of labor could result in delays, expenses, and other challenges to the City's future construction projects; and

WHEREAS, the City of Tampa has determined that apprenticeships create opportunities for training and experience that will assist in ensuring that a trained workforce will be available for future City construction projects; and

WHEREAS, requiring the employment of apprentices on certain City of Tampa construction projects will promote business and economic development by increasing the number of skilled workers in the City; and

WHEREAS, the City of Council of the City of Tampa has determined that the creation of Chapter 26.5, Article IV, pertaining to Apprentice Requirements in City Construction Projects, is appropriate and in the interest of the public health, safety or welfare of the City of Tampa at this time; and

WHEREAS, duly noticed public hearings, as required by law, were held by the City Council of the City of Tampa at which all residents and interested persons were given an opportunity to be heard.

1
2
3
4
5
6
7
8
9
10
11
12
13
14
15
16
17
18
19
20
21
22
23
24
25
26
27
28
29
30
31
32
33
34
35
36
37
38
39
40
41

NOW, THEREFORE,

**BE IT ORDAINED BY THE CITY COUNCIL
OF THE CITY OF TAMPA, FLORIDA:**

Section 1. That the recitals set forth above are hereby incorporated as if fully set forth herein.

Section 2. That the City of Tampa Code, Section 26.5, is hereby amended by creating Article IV, Sections 26.5-211 through 26.5-216, to read as follows:

“ARTICLE IV.- APPRENTICE REQUIREMENTS IN CITY CONSTRUCTION CONTRACTS

DIVISION 1. - IN GENERAL

Sec 26.5-211. – Title; Applicability.

This Article IV shall be known and may be cited as the “City of Tampa Apprentice Requirements in City Construction Contracts Ordinance”. This Article shall apply to contracts for certain City of Tampa construction projects as specified in more detail herein.

Sec. 26.5-212. Legislative Findings and Intent.

(a) There is a shortage of skilled labor for construction projects and a need to train younger workers as the existing job force ages. This shortage of labor could result in delays, expenses, and other challenges to the City's future construction projects. Apprenticeships create opportunities for training and experience that will assist in ensuring that a trained workforce will be available for future City construction projects. By requiring contactors to use apprentices for City construction contracts, it is the intent of the City to increase the number of apprentices used by contractors, creating opportunities that will enable these apprentices to develop into more skilled labor that will then be available for City construction projects.

(b) Apprenticeship programs are recognized as an effective means of providing training and experience to individuals seeking to enter or advance in the workforce, offering an opportunity to earn wages while acquiring valuable marketable skills. The training that apprentices receive on city projects will also help them to market their skills to other contractors. In this way, apprenticeship training helps create a skilled pipeline of talent to support and sustain ongoing economic development activities in the City of Tampa.

Sec.26.5-213. - Definitions.

Apprentice means any person who is enrolled in and participating in an apprenticeship program or on-the-job training program registered with the Florida Department of Education or the United States Department of Labor, or in

1 a registered on-the-job training program, as defined in Chapter 446, Florida
2 Statutes.

3 *Bidder* means any individual, firm, corporation, partnership, company,
4 association, joint venture, or other entity that seeks the award of a construction
5 contract.

6 *Contractor* means any individual, firm, corporation, partnership, company,
7 association, joint venture, or other entity that has a construction contract with the
8 City.

9 *Construction contract*, for purposes of this article, means a contract
10 between the City and a contractor for a vertical construction project, as defined
11 herein. By no later than one year after implementation of this ordinance, this
12 definition shall be expanded to include horizontal construction projects, as also
13 defined herein.

14 *Vertical construction project* means a project, funded by City dollars in an
15 amount of at least one million dollars (\$1,000,000) priced on the basis of a lump
16 sum/fixed price amount, that involves the process of building, altering, repairing,
17 improving, or demolishing any public structure or building, or other public
18 improvements of any kind that are predominantly vertical (i.e., above-ground), on
19 or to any real property owned or under the control of the City, which work is being
20 performed under a construction contract. For purposes of this article, vertical
21 construction also includes on-site horizontal work that is integral to or part of the
22 vertical construction project.

23 *Horizontal construction project* means a project, funded by City dollars in
24 an amount of at least one million dollars (\$1,000,000) priced on the basis of a
25 lump sum/fixed price amount, that involves construction of highways, roads,
26 streets, bridges, utilities, water distribution or transmission pipelines, wastewater
27 interceptors, force mains or collection systems, and stormwater conveyance
28 facilities. For purposes of this article, horizontal construction also includes
29 rehabilitation of water, wastewater and stormwater pipelines including, but not
30 limited to, cured-in place, pulled-in place and pipe bursting methods.

31 *Good faith effort* means that the contractor, without an intent to defraud
32 or seek an unfair advantage, took all necessary steps to secure and maximize,
33 consistent with the requirements of this section, the required percentage for
34 apprentices on a construction project, to the satisfaction of the City of Tampa.
35 The contractor shall provide evidence of good faith efforts for consideration by
36 the City, which evidence may include documentation of the contractor's contacts

1 with the Florida Department of Education, Division of Career and Adult
2 Education's Apprenticeship Section; documentation of its contacts with state-
3 approved training programs, with labor organizations, and/or with technical
4 schools and training schools; documentation of its use of job fairs and other
5 outreach efforts; the frequency and duration of any employment advertisements
6 for apprentices; the extent to which the size of a contractor's workforce affects its
7 hiring opportunities for apprentices; and any other evidence demonstrating to the
8 satisfaction of the City that the contractor made a good faith attempt to secure
9 apprentice labor.

10 *Subcontractor* means an entity or individual providing services to the City
11 through a contractor for all or any portion of the construction contract.

12 *Labor hours* means the total hours worked on the site of a construction
13 project by workers who are employed by contractors or subcontractors on the
14 construction project, excluding hours worked by forepersons, superintendents, or
15 owners. Notwithstanding the above, the percentage requirements of this article
16 shall apply to the labor hours performed in a trade(s) for which registered
17 apprenticeship programs or on-the-job training programs exist.

18 **Sec. 26.5-214. - Apprenticeship Requirements and Exceptions.**

19 (a) When responding to a City of Tampa solicitation for a vertical construction project, a
20 bidder must certify that:

- 21 (1) The bidder or its subcontractors participate in an apprenticeship program that is
22 registered with the Florida Department of Education or the United States
23 Department of Labor; or
- 24 (2) The bidder commits that at the time the bidder executes a construction contract,
25 it or its subcontractors will be participating in an apprenticeship program that is
26 approved by the Florida Department of Education or the United States
27 Department of Labor or an on-the-job training program; or
- 28 (3) The bidder has submitted documentation that confirms, to the satisfaction of the
29 City of Tampa, that there are no registered apprenticeship or on-the-job training
30 programs for any type of work to be performed on the construction project.

31 (b) Prior to the City entering a construction contract, the City must receive
32 documentation from the bidder verifying compliance with Section 26-214(a).

33 (c) For the duration of the construction contract, as same may be extended including
34 through the issuance of change orders, at least 12% of the labor hours performed in
35 a trade(s) for which registered apprenticeship programs or on-the-job training
36 programs exist, including all work performed pursuant to change orders, must be

1 performed by apprentices employed by the contractor or subcontractors, with
2 required documentation provided to the City as set forth in Sec. 26-215 herein.

3 (d) If the contractor is unable to achieve or maintain the required percentage, the
4 contractor must notify the City in writing and document its good faith effort, as
5 defined herein, made to achieve or maintain the required percentage. The City will
6 then determine whether the contractor made all required good faith effort by
7 evaluating the contractor's submitted documentation.

8 (e) The construction contract between the City and the contractor must include a
9 provision requiring the contractor and its subcontractors to comply with the
10 requirements of this article.

11 (f) Exceptions.

12 (1) This article will not apply if:

13 a. It is prohibited by or in conflict with federal or state law or the terms of a
14 federal or state grant applicable to the construction project; or

15 b. The Mayor or the Mayor's designee determines that emergency
16 circumstances exist such that applying the article to the construction project
17 is not in the best interest of the City.

18 (2) This article will not apply to a subcontractor that is a WMBE or SLBE if the
19 compensation to be paid under the applicable subcontract for labor costs is less
20 than \$1,000,000.

21 (3) The twelve percent (12%) requirement of labor hours on the construction
22 project that must be performed by apprentices may be reduced by the Mayor or
23 the Mayor's designee if:

24 a. The contractor has successfully demonstrated to the City, after making a
25 good faith effort as defined herein, that the contractor has been unable to
26 find, or there does not exist, a sufficient number or type of apprentices
27 available to meet the required percentage; or

28 b. The Mayor or the Mayor's designee determines that there exists, for the
29 construction project at issue, a disproportionately high ratio of material
30 costs to labor hours, which makes infeasible the required percentage of
31 apprentice participation.

32
33 **Sec. 26.5-215. - Required Documentation, Incentive for Compliance, and**
34 **Noncompliance Fee and Other Remedies.**

35
36 (a) *Required documentation.* The contractor must prepare, submit, and certify, on a
37 monthly basis for the duration of the construction contract, accurate and timely
38 records, on a form prepared by the City, identifying the name, hourly rate, and trade
39 classification of each apprentice, the cumulative number of hours worked on the

1 project to date by apprentices, and the labor hours of all workers used by the
2 contractor and each subcontractor on the construction project. If a subcontractor
3 uses apprentices that will be included to satisfy the 12% requirement set forth herein,
4 the contractor must require that the subcontractors prepare, maintain, and certify,
5 for submittal by the contractor to the City, accurate and timely records, on a form
6 prepared by the City, identifying for such subcontractor, the name, hourly rate, trade
7 classification, labor hours for apprentices used by the subcontractor on the
8 construction project, and labor hours of all workers used by the subcontractor on the
9 construction project.

10 (b) *Incentive for Compliance.* At the point at which a contract is 50% complete, the City
11 will reduce 1% of the retainage, provided the City has determined that (i) the
12 contractor is in compliance with the percentage requirements of subsection 26.5-
13 214(c) for the work performed to date, and (ii) is otherwise performing its contract
14 obligations to the full satisfaction of the City.

15 (c) *Fee for Partial Compliance or Noncompliance.* Contracts for all projects to which these
16 requirements apply will provide that if a contractor fails to fully comply with the
17 percentage requirements of subsection 26.5-214(c), and the requirement is not
18 adjusted in writing by the Mayor or the Mayor's designee, as provided for above, the
19 contractor will be assessed a penalty fee amount for each hour that is not achieved.

20 1. The amount per hour shall be based on the extent to which the contractor or
21 subcontractor met the 12% labor hour requirement. The fee schedule for the
22 amount per hour that will be assessed shall be adopted by Resolution.

23 2. The assessments imposed shall be deducted from the contractor's final pay
24 application and shall be utilized to support construction/building trade apprentice
25 training programs registered with the State of Florida or the United States
26 Department of Labor and located within Hillsborough County, and/or such
27 apprentice training programs provided by the Hillsborough County School District.

28 (d) *Noncompliance-Other Remedies.* Failure of a contractor to comply with the
29 requirements of this article may subject the contractor to all remedies available to the
30 City at law, including but not limited to debarment or suspension of the contractor
31 from consideration for the award of future contracts, and termination of the
32 construction contract.

33 **Sec. 26.5-216.- Implementation, Expansion of Scope to include Horizontal Construction,**
34 **and Reporting.**

35 (a) *Implementation.* The Mayor or the Mayor's designee shall implement the provisions
36 of this ordinance no later than six months from its effective date.

37 (b) *Expansion of the Scope of the Apprentice Requirements to apply to Horizontal*
38 *Construction.* By no later than twelve months after implementation of this ordinance,
39 this article shall be amended as necessary to expand its application to horizontal
40 construction contracts, as defined herein.

1 (c) *Reporting.* At six month intervals during the first year after implementation of this
2 article, and thereafter on an annual basis, the Mayor or the Mayor's designee shall
3 prepare a report to be presented on the agenda of the City Council, that includes for
4 each contract to which this article applies, a line item breakdown of: the name of the
5 contractor, the name or description of the construction project, the total dollar value
6 of the construction project, the number of apprentices hired for the construction
7 project, the number of apprentice hours worked on the construction project, and the
8 total labor hours expended on the construction project. Additionally, the report will
9 identify any contracts where the 12% requirement was not met, and the reason; a
10 report on outreach efforts made by the City Council and the City Administration, along
11 with any other relevant details or recommendations regarding the City's
12 apprenticeship requirements that the Mayor or the Mayor's designee wish to include.

13
14 **Section 3.** That all ordinances or parts of ordinances in conflict herewith are repealed
15 to the extent of any conflict with the terms of this ordinance.

16
17 **Section 4.** That if any part of this Ordinance shall be declared unconstitutional or
18 invalid by a court of competent jurisdiction, the remaining provisions shall remain in full
19 force and effect.

20
21 **Section 5.** Except to the extent expressly addressed herein, this Ordinance shall take
22 effect immediately upon becoming a law.

23
24
25 PASSED AND ORDAINED BY THE CITY COUNCIL OF THE CITY OF TAMPA,
26 FLORIDA, ON March 18, 2021.

27
28
29 
30 _____
31 CHAIRMAN/CHAIRMAN PRO-TEM,
32 CITY COUNCIL

33 ATTEST;

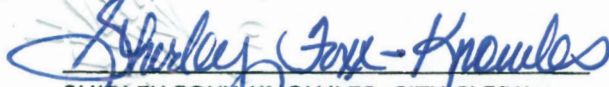
34 
35 _____
36 SHIRLEY FOXX-KNOWLES, CITY CLERK

37
38 APPROVED BY ME ON 3/22/21

39
40 
41 _____
42 JANE CASTOR, MAYOR
43

RESOLUTION 2021 - _____

RESOLUTION ESTABLISHING A SCHEDULE OF FEES FOR PARTIAL COMPLIANCE OR NONCOMPLIANCE WITH APPRENTICE LABOR HOUR PERCENTAGE REQUIREMENTS PURSUANT TO CHAPTER 26.5, ARTICLE IV. APPRENTICE REQUIREMENTS IN CITY CONSTRUCTION CONTRACTS, SUBSECTION 26.5-215(c)1, OF THE CITY OF TAMPA CODE; PROVIDING AN EFFECTIVE DATE.

WHEREAS, on March 18, 2021, City Council adopted Ordinance No. 2021-33, which added Chapter 26.5, Article IV., Apprentice Requirements in City Construction Projects, Sections 26.5-211 through 26.5-216, to the City of Tampa Code (the “Apprentice Ordinance”); and

WHEREAS, Subsection 26.5-215(c) provides for the assessment of a fee for partial compliance or noncompliance with the apprentice labor hour percentage requirements of subsection 26.5-214(c), with the fee amount to be based on the extent to which the contractor or subcontractor met the apprentice labor hour requirements under the ordinance; and

WHEREAS, Subsection 26.5-215(c)1. provides for the adoption of a fee schedule by Resolution; and

WHEREAS, the fees established pursuant to this Resolution are reasonable and are consistent with the purpose, intent and express requirements of the Apprentice Ordinance.

NOW, THEREFORE,

BE IT RESOLVED BY THE CITY COUNCIL OF THE CITY OF TAMPA, FLORIDA:

Section 1. That pursuant to the authority of Section 26.5-215(c)1., the following is the schedule of fees for partial compliance or noncompliance with the apprentice labor hour requirements of subsection 26.5-214(c), City of Tampa Code:

| Percent of goal met | Assessment per unmet hour |
|---------------------|---------------------------|
| 100% | \$0.00 |
| 90% to 99% | \$2.50 |
| 75% to 89% | \$5.25 |
| 50% to 74% | \$8.00 |
| 1% to 49% | \$11.25 |
| 0% | \$15.00 |

Section 2. That the proper officers of the City of Tampa are hereby authorized and directed to do all things necessary and proper in order to carry out and make effective the provisions of this resolution.

Reference Links:

- [Florida Department of Education Apprenticeship Programs](#)
- [Apprenticeship Florida](#)
- [U.S. Department of Labor Apprenticeship Resources](#)
- [U.S. Department of Labor Apprenticeship Standards Builder and User Guide](#)

CITY OF TAMPA INSURANCE REQUIREMENTS

Prior to commencing any work or services or taking occupancy under that certain written agreement or award (for purposes of this document, Agreement) between the City of Tampa, Florida (City) and Firm/Awardee/Contractor/Consultant/Lessee/non-City party, etc. (for purposes of this document, Firm) to which this document is attached and incorporated as an Exhibit or otherwise, and continuing during the term of said Agreement (or longer if the Agreement and/or this document so requires), Firm shall provide, pay for, and maintain insurance against claims for injuries to persons (including death) or damages to property which may arise from or in connection with the performance of the Agreement (including without limitation occupancy and/or use of certain property/premises) by Firm, its agents, representatives, employees, suppliers, subtenants, or subcontractors (which term includes sub-consultants, as applicable) of any tier subject to the terms and conditions of this document. Firm's maintenance of insurance coverage as required herein is a material element of the Agreement and the failure to maintain or renew coverage or provide evidence of same (defined to include without limitation Firm's affirmative duty to provide from time to time upon City's request certificates of insurance, complete and certified copies of Firm's insurance policies, forms, and endorsements, information on the amount of claims payments or reserves chargeable to the aggregate amount of coverage(s) whether during the term of the Agreement or after as may be requested by the City in response to an issue or potential claim arising out of or related to the Agreement to which Firm's insurance obligations hereunder may apply or possibly help mitigate) may be treated as a material breach of the Agreement. Should at any time Firm not maintain the insurance coverages required, City at its sole option (but without any obligation or waiver of its rights) may (i) terminate the Agreement or (ii) purchase such coverages as City deems necessary to protect itself (charging Firm for same) and at City's option suspending Firm's performance until such coverage is in place. If Firm does not reimburse City for such costs within 10 days after demand, in addition to any other rights, City shall also have the right to offset such costs from amounts due Firm under any agreement with the City. All provisions intended to survive or to be performed subsequent to the expiration or termination of the Agreement shall survive, including without limitation Firm's obligation to maintain or renew coverage, provide evidence of coverage and certified copies of policies, etc. upon City's request and/or in response to a potential claim, litigation, etc.

The City reserves the right from time to time to modify or waive any or all of these insurance requirements (or to reject policies) based on the specific nature of goods/services to be provided, nature of the risk, prior experience, insurer, coverage, financial condition, failure to operate legally, or other special circumstances. If Firm maintains broader coverage and/or higher limits than the minimums shown herein, the City requires and shall be entitled to such broader coverage and/or higher limits maintained by Firm. Any available insurance proceeds in excess of the specified minimum limits of insurance and coverage shall be available to the City. No representation is made that the minimum insurance requirements are sufficient to cover Firm's interests, liabilities, or obligations. Required insurance shall not limit Firm's liability.

Firm acknowledges and agrees Firm and not the City is the party in the best position to determine applicability (e.g. "IF APPLICABLE"), confirm, and/or verify its insurance coverage. Acceptance by the City, or by any of its employees, representatives, agents, etc. of certificates or other documentation of insurance or policies pursuant to the terms of this document and the Agreement evidencing insurance coverages and limits does not constitute approval or agreement that the insurance requirements have been met or that coverages or policies are in compliance. Furthermore, receipt, acceptance, and/or approval of certificates or other documentation of insurance or policies or copies of policies by the City, or by any of its employees, representatives, agents, etc., which indicate less coverage than required does not constitute a waiver of Firm's obligation to fulfill these insurance requirements.

MINIMUM SCOPE AND LIMIT OF INSURANCE ¹

A. Commercial General Liability (CGL) Insurance on the most current Insurance Services Office (ISO) Form CG 00 01 or its equivalent on an "occurrence" basis (Modified Occurrence or Claims Made forms are not acceptable without prior written consent of the City). Coverage must be provided to cover liability contemplated by the Agreement including without limitation premises and operations, independent contractors, contractual liability, products and completed operations, property damage, bodily, personal and advertising injury, contractual liability, explosion, collapse, underground coverages, personal injury liability, death, employees-as-insureds. Products and completed operations liability coverage maintained for at least 3 years after completion of work. Limits shall not be less than \$1M per occurrence and \$2M general aggregate for Agreements valued at \$2M or less; if valued over \$2M, a general aggregate limit that equals or exceeds the Agreement's value. If a general aggregate limit applies; it shall apply separately to the project/location (ISO CG 2S 03 or 2S 04 or equivalent). **(ALWAYS APPLICABLE)**

B. Automobile Liability (AL) Insurance in accordance with Florida law, as to the ownership, maintenance, and use of all owned, non-owned, leased, or hired vehicles. AL insurance shall not be less than: (a) \$500,000 combined single limit each occurrence bodily injury and property damage for Agreements valued at \$100,000 or less or (b) \$1M combined single limit each occurrence bodily injury and property damage for Agreements valued over \$100,000. If transportation of hazardous material involved, the MCS-90 endorsement (or equivalent). **(ALWAYS APPLICABLE)**

C. Worker's Compensation (WC) & Employer's Liability Insurance for all employees engaged under the Agreement, Worker's Compensation as required by Florida law. Employer's Liability with minimum limits of (a) \$500,000 bodily injury by accident and each accident, bodily injury by disease policy limit, and bodily injury by disease each employee for Agreements valued at \$100,000 and under or (b) \$1M bodily injury by accident and each accident, bodily injury by disease policy limit, and bodily injury by disease each for all other Agreements. **(ALWAYS APPLICABLE)**

D. Excess (Umbrella) Liability Insurance for Agreements valued at \$2M or more, at least \$4M per occurrence in excess of underlying limits and no more restrictive than underlying coverage for all work performed by Firm. May also compensate for a deficiency in CGL, AL, or WC. **(ALWAYS APPLICABLE)**

E. Builder's Risk Insurance for property loss exposure associated with construction/renovation/additions to buildings or structures, including materials or fixtures to be incorporated. Must be "All Risk" form with limits of no less than the project's completed value, have no coinsurance penalties, eliminate the "occupancy clause", cover Firm (together with its contractors, subcontractors of every tier, and suppliers), and name City as a Loss Payee. **(IF APPLICABLE)**

F. Installation Floater coverage for property (usually highly valued equipment or materials such as compressors, generators, etc.) during its installation. Coverage must be "All Risk" including installation and transit for no less than 100% of the installed replacement cost value. **(IF APPLICABLE)**

G. Architects & Engineers Liability/ Professional Liability (E&O)/ Contractors Professional Liability (CPL)/ Medical Malpractice Insurance where Agreement involves Florida-regulated professional services (e.g. architect, engineer, design-builder, CM, accountant, appraiser, investment banker medical professional) at any tier, whether employed or independent, vicarious design liability exposure (e.g. construction means & methods, design supervision), value engineering, constructability assessments/reviews, BIM process, and/or performance specifications. Limits of at least \$1M per occurrence and \$2M aggregate; deletion of design/ build liability exclusions, as applicable, and maintained for at least 3 years after completion of work/services and City's acceptance of same. **(IF APPLICABLE)**

H. Railroad Protective Liability CRPL Insurance for construction within 50ft of operated railroad track(s) or where affects any railroad bridge, trestle, tunnel, track(s) roadbed, or over/under pass. Subject to involved rail road's approval prior to commencement of work. **(IF APPLICABLE)**.

I. Pollution and/or Asbestos Legal Liability Insurance where Agreement involves asbestos and/or environmental hazards/contamination risks (defined broadly, e.g. lead, mold, bacteria, fuel storage, underground work, cleanup (owned or non-owned sites), pollutant generation/transportation, marine/natural resource damage, contamination claim, restitution, business interruption, mold, fungus, lead-based paint, 3rd party claims/removal, etc.), with limits of at least \$1M per occurrence and \$2M aggregate, maintained for at least 3 years after Agreement completion. **(IF APPLICABLE)**

J. Cyber Liability Insurance where Agreement involves portals allowing access to obtain, use, or store data; managed dedicated servers; cloud hosting services; software/hardware; programming; and/or other IT services

¹ "M" indicates million(s), for example \$1M is \$1,000,000

and products are involved. Limits of not less than \$2M per occurrence and \$2M aggregate. Coverage sufficiently broad to respond to duties and obligations undertaken by Firm, and shall include, but not be limited to, claims involving infringement of intellectual property/copyright, trademark, trade dress, invasion of privacy violations, damage to or destruction of electronic information, information theft, release of confidential and/or private information, alteration of electronic information, extortion, virus transmission, and network security. Coverage, as applicable and with sufficient limits to respond, for breach response costs, regulatory fines and penalties, credit monitoring expenses. **(IF APPLICABLE)**

K. Drone/UAV Liability Insurance where Agreements involves unmanned aerial vehicles/drones. Coverage to include products and completed operations, property damage, bodily injury with limits no less than \$1M per occurrence, and \$2M aggregate; may be provided by CGL endorsement subject to City's prior written approval. **(IF APPLICABLE)**

L. Longshore & Harbor Workers' Compensation Act/Jones Act for work being conducted near, above, or on "navigable waters" for not less than the above Employer's Liability Insurance limit. **(IF APPLICABLE)**

M. Garagekeeper/Hangerkeeper/Marina Operator Legal Liability Insurance and/or Hull/P&I Insurance where parking lot, valet, dealership, garage services, towing, etc. and/or operation of a hangar, marina, or air

plane/ship repairer, providing safe berth, air/watercraft storage/docking (on land/ in water), fueling, tours, charters, ferries, dredges, tugs, mooring, towing, boat/aircraft equipment/repair/alteration/maintenance, etc.; cover- age against liability for damage to vehicles air/watercraft, their machinery in Firm's care, custody, or control both private & commercial. Limits at least equal to greater of \$1M, value of max number of vehicles that may be in Firm's custody, or of most costly object in Firm's custody. **(IF APPLICABLE)**

N. Property Insurance and Interruption of Business CIOB) Insurance where premises, building, structure, or improved real property is leased, licensed, or otherwise occupied by Firm. Property Insurance against all risks of loss to any occupant/tenant improvements at full replacement cost with no coinsurance penalty, including fire, water, leak damage, and flood, as applicable, vandalism and malicious mischief endorsements. IOB by which minimum monthly rent will be paid to City for up to 1 year if premises are destroyed, rendered inaccessible or untenable, including disruption of utilities, water, or telecommunications. **(IF APPLICABLE)**

O. Liquor Liability/Host Liquor Liability where Firm directly or indirectly provides alcoholic beverages, limits of at least \$1M per occurrence and \$1M aggregate. **(IF APPLICABLE)**

P. Educators Legal Liability Insurance where day care, after school program, recreational activities, etc. limits per G above. **(IF APPLICABLE)**

ADDITIONAL REQUIREMENTS

ACCEPTABILITY OF INSURERS- Insurance is to be placed with insurers admitted in the State of Florida and who have a current A.M. Best rating of no less than **A:-VII** or, if not rated by A.M. Best, as otherwise approved by the City in advance and in writing.

ADDITIONAL INSURED - **City, its elected officials, departments, officers, officials, employees, and volunteers together with, as applicable, any associated lender of the City shall be covered as additional insureds on all liability coverage** (e.g. CGL, AL, and Excess (Umbrella) Liability) as to liability arising out of work or operations performed by or on behalf of Firm including materials, parts, or equipment furnished in connection with such work or operations and automobiles owned, leased, hired, or borrowed by or on behalf of Firm. Coverage can be provided in the form of an endorsement to Firm's insurance (at least as broad as ISO Form CG 20 10 11 85 or **both** CG 10 20, CG 20 26, CG 20 33, or CG 20 38 **and** CG 20 37 if later revisions used).

CANCELLATION/NON-RENEWAL – Each insurance policy shall provide that at least 30 days written notice must be given to City of any cancellation, intent to non-renew, or material reduction in coverage (except aggregate liability limits) and at least 10 days' notice for non-payment of premium. Firm shall also have an independent duty to notify City in like manner, within 5 business days of Firm's receipt from its insurer of any notices of same. If any policy's aggregate limit is reduced, Firm shall directly take steps to have it reinstated. Notice and proof of renewal/continued coverage/certifications, etc. shall be sent to the City's notice (or Award contact) address as stated in the Agreement with a copy to the following:

- Contract Administration Department, 306 E Jackson St, Tampa, FL 33602 Purchasing Department, 306 E Jackson Street, Tampa, FL 33602
 Other: _____

CERTIFICATE OF INSURANCE (COI) – to be provided to City by insurance carrier prior to Firm beginning any work/services or taking occupancy and, if the insurance expires prior to completion of the work or services or Agreement term (as may be extended), a renewal COI at least 30 days before expiration to the above address(es). COIs shall specifically identify the Agreement and its subject (project, lease, etc.), shall be sufficiently comprehensive to insure City (named as additional insured) and Firm and to certify that coverage extends to subcontractors' acts or omissions, and as to permit the City to determine the required coverages are in place without the responsibility of examining individual policies. **Certificate Holder must be The City of Tampa, Florida.**

CLAIMS MADE – If any liability insurance is issued on a claims made form, Firm agrees to maintain such coverage uninterrupted for at least 3 years following completion and acceptance of the work either through purchase of an extended reporting provision or purchase of successive renewals. The Retroactive Date must be shown and be a date not later than the earlier of the Agreement date or the date performance/occupancy began thereunder.

DEDUCTIBLES/ SELF-INSURED RETENTIONS (SIR) – must be disclosed to City and, if over \$500,000, approved by the City in advance and in writing, including at City's option being guaranteed, reduced, or eliminated (additionally if a SIR provides a financial guarantee guaranteeing payment of losses and related investigations, claim administration, and defense expenses). Firm shall be fully responsible for any deductible or SIR (without limiting the foregoing a policy with a SIR shall provide or be endorsed to provide that the SIR may be satisfied by either the City or named insured). In the event of loss which would have been covered but for a deductible or SIR, City may withhold from any payment due Firm, under any agreement with the City, an amount equal to same to cover such loss should full recovery not be obtained under the policy.

PERFORMANCE- All insurance policies shall be fully performable in Hillsborough County, Florida (the County), and construed in accordance with Florida law. Further, all insurance policies must expressly state that the insurance company will accept service of process in the County and that the exclusive venue for any action concerning any matter under those policies shall be in the appropriate state court of the County.

PRIMARY POLICIES - Firm's insurance coverage shall be primary insurance coverage at least as broad as ISO CG 20 01 04 13 as to the City, its elected officials, departments, officers, employees, and volunteers. Any insurance or self-insurance maintained by the City, its elected officials, departments, officers, employees, and volunteers shall be excess of the Firm's insurance and shall not contribute with it.

SUBCONTRACTORS/INDEPENDENT ASSOCIATES/CONSULTANTS/SUBTENANTS/SUBLICENSEE - **Firm shall require and verify that all such entities maintain insurance meeting all requirements stated herein with the City as an additional insured** by endorsement (ISO FORM CG 20 38, or broader) or otherwise include such entities within Firm's insurance policies. Upon City's request, Firm shall furnish complete and certified copies of copies of such entities' insurance policies, forms, and endorsements.

SUBCONTRACTOR DEFAULT INSURANCE CONTROLLED INSURANCE PROGRAM, WRAP-UP. Use requires express prior written consent of City Risk Manager.

UNAVAILABILITY- To the fullest extent permitted by law, if Firm is out of business or otherwise unavailable at the time a claim is presented to City, Firm hereby assigns to the City all of its right, title and interest (but not any liabilities or obligations) under any applicable policies of insurance.

WAIVER OF SUBROGATION – With regard to any policy of insurance that would pay third party losses, Firm hereby grants City a waiver of any right to subrogation which any insurer of Firm may acquire against the City by virtue of the payment of any loss under such insurance. Firm agrees to obtain any endorsement that may be necessary to affect such waiver, but this provision shall apply to such policies regardless.

WAIVER/RELEASE AGREEMENT – Where Firm has a defined group of persons who might be exposed to harm (e.g. participants in an athletic event/program, volunteers) any waiver or release agreement used by Firm whereby such persons (and their parent/guardian as applicable) discharge Firm from claims and liabilities, shall include the City, its elected officials, departments, officers, officials, employees, and volunteers to the same extent as Firm.

Procurement Guidelines To Implement Minority & Small Business Participation

Underutilized WMBE Primes by Industry Category

| FORMAL PROCUREMENT | Construction | Construction-Related | Professional | Non-Professional | Goods |
|---------------------------|--------------|----------------------|--------------|------------------|------------|
| | Black | Asian | Black | Black | Black |
| | Hispanic | Native Am. | Hispanic | Asian | Hispanic |
| | Native Am. | Woman | Asian | Native Am. | Asian |
| | Woman | | Native Am. | | Native Am. |
| | | | Woman | | Woman |

Underutilized WMBE Sub-Contractors / Sub-Consultants

| SUB WORK | Construction | Construction-Related | Professional | Non-Professional | Goods |
|-----------------|--------------|----------------------|--------------|------------------|------------|
| | Black | Black | Black | Black | Black |
| | | Asian | Hispanic | Asian | Asian |
| | | Native Am. | Asian | Native Am. | Native Am. |
| | | Woman | Native Am. | | Woman |
| | | | Woman | | |

Policy

The Guidelines apply to formal procurements and solicitations. WMBE participation will be narrowly-tailored.

Index

- Black = Black/African-American Business Enterprise
- Hispanic = Hispanic Business Enterprise
- Asian = Asian Business Enterprise
- Native Am. = Native American Business Enterprise
- Woman = Woman Business Enterprise (Caucasian)

Industry Categories

Construction is defined as: new construction, renovation, restoration, maintenance of public improvements and underground utilities.

Construction-Related Services are defined as: architecture, professional engineering, landscape architecture, design build, construction management services, or registered surveying and mapping.

Professional Services are defined as: attorney, accountant, medical doctor, veterinarian, miscellaneous consultant, etc.

Non-Professional Services are defined as: lawn maintenance, painting, janitorial, printing, hauling, security guard, etc.

Goods are defined as: all supplies, materials, pipes, equipment, machinery, appliances, and other commodities.

MBD Form-70

**Citywide Meter Hydrant Valve Installation Replacement
 FY22 Project 22-C-00034
 U-WMBE Availability Contact List
 (The Underutilized WMBE Industry Category for Construction Subcontracts is BBE)**

| This Certified Contact List is the minimum contacts available and may require further searches for certified firms to meet Good Faith Efforts. | | | | | | | | | | | | |
|--|---|--------------|--------------|---------------------------------------|----------------------------------|----------------|-------|-------|-------------------------------|------------|------------|------------------|
| #'s | Business Name | Phone | Fax | Email | Address 1 | City | State | Zip | Business Description | FEIN | Cert. Type | Ethnicity |
| 1 | Aviman Management, LLC | 302-377-5788 | 302-543-7403 | levi@avimanmanagement.com | 550 N Reo Street | Tampa | FL | 33609 | Pipe&Valve Supply | 320098022 | BBE | African American |
| 1 | SUCA Pipe Supply Inc. | 813-249-7902 | | slmau44@yahoo.com | 4910 Lowell Rd | Tampa | FL | 33624 | Pipe Supply | 992499571 | BBE | African American |
| 1 | Suca Pipe Supply, Inc. One | 813-249-7902 | | mactwinai1@yahoo.com | 4910 Lowell Road | Tampa | FL | 33624 | Pipe Supply | 263669556 | BBE | African American |
| 1 | TERRELL INDUSTRIES, INC. | 727-823-4424 | 727-823-3977 | gradyterrell@terrellindustries.com | 2067 1ST AVENUE NORTH | ST PETERSBURG | FL | 33713 | Pipe Supply | 950530148 | BBE | African American |
| 2 | Aviman Management, LLC | 302-377-5788 | 302-543-7403 | levi@avimanmanagement.com | 550 N Reo Street | Tampa | FL | 33609 | Roadway Bricks, Pavers&Stone | 320098022 | BBE | African American |
| 2 | Fresh Start Development, Inc. | 813-758-5345 | 813-333-5949 | freshstartdevelop@yahoo.com | 5508 N 50th St | Tampa | FL | 33610 | Roadway Bricks, Pavers&Stone | 203857845 | BBE | African American |
| 2 | LMCC Specialty Contractors | 407-298-6936 | 407-290-1217 | lynn@lmccsconstruction.com | 119 S. Pine hills Rd. | Orlando | FL | 32811 | Roadway Bricks, Pavers&Stone | 993442318 | BBE | African American |
| 2 | WC Boxes, Inc. | 813-478-1102 | 813-864-4386 | wcindustries2003@gmail.com | 17620 Lake Key Drive | Odessa | FL | 33556 | Roadway Bricks, Pavers&Stone | 472682190 | BBE | African American |
| 3 | Aviman Management, LLC | 302-377-5788 | 302-543-7403 | levi@avimanmanagement.com | 550 N Reo Street | Tampa | FL | 33609 | Concrete Curb | 320098022 | BBE | African American |
| 3 | E/S Concrete Service, Inc. | 727-560-0957 | 727-821-5029 | enorisslysr@yahoo.com | 726 E. Harbor Drive | St. Petersburg | FL | 33705 | Concrete Curb | 993119582 | BBE | African American |
| 4 | E/S Concrete Service, Inc. | 727-560-0957 | 727-821-5029 | enorisslysr@yahoo.com | 726 E. Harbor Drive | St. Petersburg | FL | 33705 | Concrete Driveways, Sidewalks | 993119582 | BBE | African American |
| 4 | Excel 4 LLC | 407-480-8976 | 407-480-8976 | excel4llc@yahoo.com | 318 N. John Young Parkway Ste #6 | Kissimmee | FL | 34741 | Concrete Driveways, Sidewalks | 4654149326 | BBE | African American |
| 5 | BUN Construction Co., Inc. | 813-931-8270 | 813-931-9185 | bunconstruction@tampabay,rr.com | 4135 E. Hillsborough Avenue | Tampa | FL | 33610 | Roadway Restoration | 993362663 | BBE | African American |
| 6 | 4678 Landscaping Incorporated | 813-850-7950 | | 4678landscapinginc@gmail.com | 11319 VILLAS ON THE GREEN DR | RIVERVIEW | FL | 33579 | Landscape&Restoration | 842268587 | BBE | African American |
| 6 | 7 Shepards Investments, LLC | 813-416-0484 | 813-991-0304 | sevenshpardsinvestmentsllc@yahoo.com | 10408 Goldenbrook Way | Tampa | FL | 33647 | Landscape&Restoration | 263264635 | BBE | African American |
| 6 | Benemon & Benemon Enterprises, LLC | 813-952-0432 | | jamesbenemon69@gmail.com | 510 HICKORY LAKE DR | BRANDON | FL | 33511 | Landscape&Restoration | 844660830 | BBE | African American |
| 6 | BUN Construction Co., Inc. | 813-931-8270 | 813-931-9185 | bunconstruction@tampabay,rr.com | 4135 E. Hillsborough Avenue | Tampa | FL | 33610 | Landscape&Restoration | 993362663 | BBE | African American |
| 6 | Cut-Ups Lawn Service | 813-361-8871 | 813-238-2397 | cutupslawnservice@yahoo.com | 3217 East Powhatan Ave. | Tampa | FL | 33610 | Landscape&Restoration | 611412916 | BBE | African American |
| 6 | Lawn Conquerors LLC | 813-444-0466 | 813-000-0000 | lawnconquerors@gmail.com | 2409 E Annie St | Tampa | FL | 33612 | Landscape&Restoration | 852605386 | BBE | African American |
| 6 | T.C.C Enterprise Inc | 813-606-9148 | 813-237-0396 | tcc_inc@live.com | 3902 E POWHATAN AVE | TAMPA | FL | 33610 | Landscape&Restoration | 463223645 | BBE | African American |
| 6 | Trimen Precision Lawn Care, LLC | 813-863-9328 | | account@trimenlandscape.com | 450 S Taylor Rd | Seffner | FL | 33584 | Landscape&Restoration | 474625126 | BBE | African American |
| 6 | Walkers landscape and lawncare services | 813-553-0549 | | bwalker1cs@gmail.com | 9821 e fowler ave | Thonotosass | FL | 33592 | Landscape&Restoration | 843912131 | BBE | African American |
| 6 | WC Boxes, Inc. | 813-478-1102 | 813-864-4386 | wcindustries2003@gmail.com | 17620 Lake Key Drive | Odessa | FL | 33556 | Landscape&Restoration | 472682190 | BBE | African American |
| 6 | Williams Landscape Management Co., Inc. | 813-628-8048 | 813-628-8041 | tonywilliams@wmlandscape.com | 5710 N 50th St | Tampa | FL | 33610 | Landscape&Restoration | 993516370 | BBE | African American |
| 6 | Works of Nature, LLC | 813-531-2324 | | Trj@workofnature.info | 1016 E.33rd Ave. | Tampa | FL | 33603 | Landscape&Restoration | 814965789 | BBE | African American |
| 7 | Battle Tested Photography | 813-943-4330 | | jl@battletestedphotos.com | 28655 Seashell Ct | Wesley Chapel | FL | 33545 | Video | 831943735 | BBE | African American |
| 7 | Kerrick Williams Photography LLC | 404-966-8145 | 866-571-7149 | kerrick@kerrickwilliams.com | 5508 N 50th St | Tampa | FL | 33610 | Video | 272468473 | BBE | African American |
| 7 | Uhora Films LLC | 813-220-2051 | | uborafilms@gmail.com | 17847 D Sailfish Drive | Lutz | FL | 33558 | Video | 821230551 | BBE | African American |
| 8 | Cornestone Barricades Inc. | 352-373-8001 | 352-377-8976 | sevi.falade@cornerstonebarricades.com | 3201 SW 42nd Street | Gainesville | FL | 32608 | Maintenance of Traffic | 810763816 | BBE | African American |

**Citywide Meter Hydrant Valve Installation Replacement
FY22 Project 22-C-00034
SLBE Availability Contact List**

| This Certified Contact List is the minimum contacts available and may require further searches for certified firms to meet Good Faith Efforts. | | | | | | | | | | | | |
|--|--|--------------|--------------|---------------------------------------|----------------------------------|----------------|-----|-------|--|-----------|-------|-------------------|
| #/s | Business Name | Phone | Fax | Email | Address 1 | City | Sta | Zip | Business Description | FEIN | Cert. | Ethnicity |
| 1 | IMBE Supply of Florida, Inc. | 813-781-6583 | | imbesupplyoflora@gmail.com | 4306 W. Osborne Avenue | Tampa | FL | 33613 | Supplier - Dirt, Pipe, Valves, Pumps, | 463284565 | SLBE | Caucasian |
| 1 | SUCA Pipe Supply Inc. | 813-249-7902 | | slmau44@yahoo.com | 4910 Lowell Rd | Tampa | FL | 33624 | Distributor-Ductile Iron And Cast Ir | 922499571 | SLBE | African American |
| 1 | Suca Pipe Supply, Inc. One | 813-249-7902 | | mactwinau1@yahoo.com | 4910 Lowell Road | Tampa | FL | 33624 | Pipe Supplier; | 263669556 | SLBE | African American |
| 1 | TLD LLC | 813-927-7554 | 813-977-5419 | tld2013@verizon.net | 14512 N. Nebraska Avenue | Tampa | FL | 33613 | Supplier - Material (Pipe, Valves, Ele | 011724437 | SLBE | Caucasian |
| 2 | Quick Construction Solutions, LLC | 813-377-9997 | 813-374-5849 | quickcs@outlook.com | 4501 N. Saint Vincent St. | Tampa | FL | 33614 | Roadway Bricks, Pavers&Stone Curt | 000972890 | SLBE | Hispanic American |
| 2 | WC Boxes, Inc. | 813-478-1102 | 813-864-4386 | wcindustries2003@gmail.com | 17620 Lake Key Drive | Odessa | FL | 33556 | Roadway Bricks, Pavers&Stone Curt | 072682190 | SLBE | African American |
| 3 | E/S Concrete Service, Inc. | 727-560-0957 | 727-821-5029 | enonissys@yahoo.com | 726 E. Harbor Drive | St. Petersburg | FL | 33705 | Concrete Curb | 093119582 | SLBE | African American |
| 3 | JMI Consulting Solutions LLC d/b/a JMI Site Development Inc. | 813-927-2484 | 813-377-2484 | jmsitedevelopment@gmail.com | 5902 Audubon Manor Blvd | Lithia | FL | 33547 | Concrete Curb | 273413832 | SLBE | Caucasian |
| 4 | AIO ENTERPRISE, LLC | 407-466-3689 | 813-436-5640 | luz@aiocenterprise.com | 13011 Perdue PL | Temple Ter | FL | 33617 | Concrete Driveways, Sidewalks&Mls | 264346308 | SLBE | Hispanic American |
| 4 | CARIA CONSTRUCTION, INC | 813-304-7158 | | Carly@puleosconcrete.com | 2010 Chickwood ct. | Tampa | FL | 33618 | Concrete Driveways, Sidewalks&Mls | 463665283 | SLBE | Caucasian |
| 4 | E/S Concrete Service, Inc. | 727-560-0957 | 727-821-5029 | enonissys@yahoo.com | 726 E. Harbor Drive | St. Petersburg | FL | 33705 | Concrete Driveways, Sidewalks&Mls | 093119582 | SLBE | African American |
| 4 | H.B. Underground Inc | 813-455-5815 | | hujo726b@gmail.com | 11500 N Dale Mabry Hwy | Tampa | FL | 33618 | Concrete Driveways, Sidewalks&Mls | 042208449 | SLBE | Hispanic American |
| 4 | JMI Consulting Solutions LLC d/b/a JMI Site Development Inc. | 813-927-2484 | 813-377-2484 | jmsitedevelopment@gmail.com | 5902 Audubon Manor Blvd | Lithia | FL | 33547 | Concrete Driveways, Sidewalks&Mls | 273413832 | SLBE | Caucasian |
| 4 | Quick Construction Solutions, LLC | 813-377-9997 | 813-374-5849 | quickcs@outlook.com | 4501 N. Saint Vincent St. | Tampa | FL | 33614 | Concrete Driveways, Sidewalks&Mls | 000972890 | SLBE | Hispanic American |
| 4 | Sunrise Utility Construction, Inc. | 813-949-3749 | 813-949-0408 | LMNBOS5@AOL.COM | P.O. Box 272293 | Tampa | FL | 33688 | Concrete Driveways, Sidewalks&Mls | 093034012 | SLBE | Caucasian |
| 5 | AJ GENERAL CONSTRUCTION SERVICES INC | 813-991-5783 | | irma@ajgeneralconstruct.com | 5415 SHAKESPEAR DR | DOVER | FL | 33527 | Roadway Restoration | 020821263 | SLBE | Hispanic American |
| 5 | BUN Construction Co., Inc. | 813-931-8270 | 813-931-9185 | bunconstruction@tampabay.rr.com | 4135 E. Hillsborough Avenue | Tampa | FL | 33610 | Roadway Restoration | 093362663 | SLBE | African American |
| 5 | Pavemaster Asphalt Paving LLC | 813-671-7500 | 813-671-7311 | enonissys@yahoo.com | PO Box 1345 | Gibsonton | FL | 33534 | Roadway Restoration | 030708817 | SLBE | Caucasian |
| 5 | Tampa Bay Construction & Engineering, Inc. | 813-984-9898 | | tampabayconstructioninc@gmail.com | 10503 Palm Cove Ave | Tampa | FL | 33647 | Roadway Restoration | 093713572 | SLBE | Caucasian |
| 6 | 4678 Landscaping Incorporated | 813-850-7950 | | 4678landscapinginc@gmail.com | 11319 VILLAS ON THE GREEN DR | RIVERVIEW | FL | 33579 | Landscapes&Restoration | 042268587 | SLBE | African American |
| 6 | 7 Shepards Investments, LLC | 813-416-0484 | 813-991-0304 | sevenshepardsinvestmentsllc@yahoo.com | 10408 Goldenbrook Way | Tampa | FL | 33647 | Landscapes&Restoration | 263264635 | SLBE | African American |
| 6 | Baron's Landscaping Services, Inc. | 813-404-1509 | 813-443-4919 | baronslawncare@aol.com | 1704 N Riverhills Drive | TEMPLE FL | FL | 33617 | Landscapes&Restoration | 050837654 | SLBE | Hispanic American |
| 6 | BENEMON & BENEMON ENTERPRISES, LLC | 813-952-0432 | | jamesbenemont69@gmail.com | 510 HICKORY LAKE DR | BRANDON | FL | 33511 | Landscapes&Restoration | 044660830 | SLBE | African American |
| 6 | BUN Construction Co., Inc. | 813-931-8270 | 813-931-9185 | bunconstruction@tampabay.rr.com | 4135 E. Hillsborough Avenue | Tampa | FL | 33610 | Landscapes&Restoration | 093362663 | SLBE | African American |
| 6 | Cut-Ups Lawn Service | 813-361-8871 | 813-238-2397 | cutupslawnservice@yahoo.com | 3217 East Powhatan Ave. | Tampa | FL | 33610 | Landscapes&Restoration | 011412916 | SLBE | African American |
| 6 | D & J LAWN SERVICES OF LAKE LAND LLC | 863-859-3525 | | DANDJLAWNSERVICES@HOTMAIL.COM | 575 Old Polk City Road | Lakeland | FL | 33809 | Landscapes&Restoration | 073279070 | SLBE | Hispanic American |
| 6 | Johnson's Excavation & Services, Inc. | 813-752-7097 | 813-719-9052 | sales@jescontracting.com | 1706 East Trapnell Road | Plant City | FL | 33566 | Landscapes&Restoration | 093031174 | SLBE | Caucasian |
| 6 | JTCM Inc | 813-935-7724 | | office@lawnsulptures.net | 817 S MacDill Ave | Tampa | FL | 33609 | Landscapes&Restoration | 062418914 | SLBE | Caucasian |
| 6 | Nelson's Tree Farm and Nursery, Inc. | 813-842-4663 | 813-350-9139 | kimberly.martinez33@gmail.com | 5027 N Lois Ave | Tampa | FL | 33614 | Landscapes&Restoration | 093404710 | SLBE | Hispanic American |
| 6 | Sunbelt Sod & Grading Company | 813-641-9855 | 813-434-9038 | lesley@sunbeltsod.com | 819 - 9th St. N.E. | Ruskin | FL | 33570 | Landscapes&Restoration | 034250933 | SLBE | Caucasian |
| 6 | T.C.C Enterprise Inc | 813-606-9148 | 813-237-0396 | tcc_inc@live.com | 3902 E POWHATAN AVE | TAMPA | FL | 33610 | Landscapes&Restoration | 063223645 | SLBE | African American |
| 6 | Tampa Bay Construction & Engineering, Inc. | 813-984-9898 | | tampabayconstructioninc@gmail.com | 10503 Palm Cove Ave | Tampa | FL | 33647 | Landscapes&Restoration | 093713572 | SLBE | Caucasian |
| 6 | Trimen Precision Lawn Care, LLC | 813-863-9328 | | account@trimenlandscapes.com | 450 S Taylor Rd | Seffner | FL | 33584 | Landscapes&Restoration | 074625126 | SLBE | African American |
| 6 | Walkers landscape and lawncare services | 813-553-0549 | | bwalker1cs@gmail.com | 9821 e fowler ave | Thonotosas | FL | 33592 | Landscapes&Restoration | 043912131 | SLBE | African American |
| 6 | WC Boxes, Inc. | 813-478-1102 | 813-864-4386 | wcindustries2003@gmail.com | 17620 Lake Key Drive | Odessa | FL | 33556 | Landscapes&Restoration | 072682190 | SLBE | African American |
| 6 | Williams Landscape Management Co., Inc. | 813-628-8048 | 813-628-8041 | tonywilliams@wilmingtonlandscapes.com | 5710 N 50th St | Tampa | FL | 33610 | Landscapes&Restoration | 093516370 | SLBE | African American |
| 6 | Works of Nature, LLC | 813-531-2324 | | Trj@workofnature.info | 1016 E.33rd Ave. | Tampa | FL | 33603 | Landscapes&Restoration | 014965789 | SLBE | African American |
| 7 | A Business Forms & Pegboard Systems, Inc. | 813-933-2788 | | social@amediamarketing.com | 3104 North Armenia Avenue, Suite | Tampa | FL | 33607 | Landscapes&Restoration | 091559977 | SLBE | Caucasian |
| 7 | Battle Tested Photography | 813-943-4330 | | jj@battletestedphotos.com | 28655 Seashell Ct | Wesley Ch | FL | 33545 | Video | 031943735 | SLBE | African American |
| 7 | Kerrick Williams Photography LLC | 404-966-6145 | 866-571-7149 | kerrick@kerrickwilliams.com | 5508 N 50th St | Tampa | FL | 33610 | Video | 072468473 | SLBE | African American |
| 7 | Uborafilms LLC | 813-220-2051 | | uborafilms@gmail.com | 17847 D Saifish Drive | Lutz | FL | 33558 | Video | 021230551 | SLBE | African American |
| 8 | Beato Group, Inc. | 813-252-0196 | | Info@BeatoGroup.com | 8961 Turnstone Haven Place | Tampa | FL | 33619 | Maintenance of Traffic | 054003966 | SLBE | Hispanic American |
| 8 | Cornerstone Barricades, Inc. | 352-373-8001 | 352-377-8976 | seyl.falade@cornerstonebarricades.com | 3201 SW 42nd Street | Gainesville | FL | 22608 | Maintenance of Traffic | 010763816 | SLBE | African American |

**Citywide Meter Hydrant Valve Installation Replacement
FY22 Project 22-C-00034
Non-UWMBE/SLBE Availability Contact List**

| This Certified Contact List is the minimum contacts available and may require further searches for certified firms to meet Good Faith Efforts. | | | | | | | | | | | | |
|--|--|--------------|--------------|--|------------------------------------|-----------------|-------|---------------------------|---------------------------|------------|------------|-------------------|
| #s | Business Name | Phone | Fax | Email | Address 1 | City | State | Zip | Business Description | FEIN | Cert. Type | Ethnicity |
| 1 | CORCEL CORP. | 407-951-7287 | 000-000-0000 | Daniel@corcelcorp.com | 2461 NW 23rd Street | Miami | FL | 33142 | Pipe Supply | 850246259 | MBE | Hispanic American |
| 1 | Florida Industrial Products, Inc. | 813-247-5356 | 813-247-6854 | david@fiponline.com | 1602 N. 39th Street | Tampa | FL | 33605 | Pipe Supply | 8992394733 | WBE | Caucasian |
| 1 | GRANDVIEW PIPE & SUPPLY CO INC | 407-383-9883 | 321-363-1066 | jc@grandviewpipe.com | 271 Spectral Point | Sanford | FL | 32771 | Pipe Supply | 8993109483 | WBE | Caucasian |
| 1 | KAT Materials Inc. | 727-834-8655 | 727-834-8670 | orders@katinc.us | 6541 Industrial Ave | Port Richey | FL | 34668 | Pipe Supply | 831019704 | WBE | Caucasian |
| 1 | MBE Supply of Florida, Inc. | 813-781-6583 | | mbsupplyoflora@gmail.com | 4306 W. Osborne Avenue | Tampa | FL | 33613 | Pipe Supply | 863284565 | WBE | Caucasian |
| 1 | TLD LLC | 813-927-7554 | 813-977-5419 | tlid2013@verizon.net | 14512 N. Nebraska Avenue | Tampa | FL | 33613 | Pipe Supply | 811724437 | WBE | Caucasian |
| 2 | Quick Construction Solutions, LLC | 813-377-9997 | 813-374-5849 | quicks@outlook.com | 4501 N. Saint Vincent St. | Tampa | FL | 33614 | Roadway Bircks, pavers&st | 900972890 | MBE | Hispanic American |
| 3 | Aireko Energy Solutions US, LLC | 407-706-2800 | | hrivero@aireko.com | 2415 W Sand Lake Rd., Ste. E | Orlando | FL | 32809 | Concrete Curb | 872826327 | MBE | Hispanic American |
| 3 | Central Florida Contractors Inc | 727-596-0708 | | sidewalks@aol.com | 13345 Pine Bark Ct | Largo | FL | 33774 | Concrete Curb | 8993119568 | WBE | Hispanic American |
| 3 | Professional Concrete, Inc. | 941-921-3660 | 941-921-5371 | david@professionalconcrete.com | 5220 Midntosh Road, Suite 1 | Sarasota | FL | 34233 | Concrete Curb | 850715612 | MBE | Hispanic American |
| 3 | Triple Crown Construction, LLC | 407-470-8021 | | clint@triplecrownllc.us | 6419 Lakeville Road | Orlando | FL | 32818 | Concrete Curb | 867170906 | MBE | Asian American |
| 4 | AIO ENTERPRISE, LLC | 407-466-3689 | 813-436-5640 | luz@aioenterprise.com | 13011 Perdue PL | Temple Terrace | FL | 33617 | Concrete Driveways, Sidew | 264346308 | MBE | Hispanic American |
| 4 | Blacktip Services, Inc. | 954-324-5300 | 321-285-2995 | blacktipemail@yahoo.com | 52 RILEY RD STE 422 | CELEBRATION | FL | 34747 | Concrete Driveways, Sidew | 274431832 | WBE | Caucasian |
| 4 | CAR/JA CONSTRUCTION, INC | 813-304-7158 | 407-864-2325 | Caryl@pulecoconcrete.com | 2010 Chickwood ct. | tampa | FL | 33618 | Concrete Driveways, Sidew | 863665283 | WBE | Caucasian |
| 4 | Central Florida Contractors Inc | 727-596-0708 | | sidewalks@aol.com | 13345 Pine Bark Ct. | Largo | FL | 33774 | Concrete Driveways, Sidew | 8993119568 | MBE | Hispanic American |
| 4 | Diamond Development LLC | 352-551-3194 | | diamantdevelopmentllc@gmail.com | 905 Spring Valley Rd | Altamonte Sprin | FL | 32714 | Concrete Driveways, Sidew | 813746486 | WBE | Caucasian |
| 4 | H.B. Underground Inc | 813-455-5815 | | hugo726b@gmail.com | 11500 N Dale Mabry Hwy | Tampa | FL | 33618 | Concrete Driveways, Sidew | 842208449 | MBE | Hispanic American |
| 4 | Liberty Concrete Structures, LLC | 407-864-2325 | | Bifonilo@libertyconcretestructures.com | Winter Garden | FL | 34787 | Concrete Driveways, Sidew | 825399301 | WBE | Caucasian | |
| 4 | Professional Concrete, Inc. | 941-921-3660 | 941-921-5371 | david@professionalconcrete.com | 5220 Midntosh Road, Suite 1 | Sarasota | FL | 34233 | Concrete Driveways, Sidew | 850715612 | MBE | Hispanic American |
| 4 | Quick Construction Solutions, LLC | 813-377-9997 | 813-374-5849 | quicks@outlook.com | 4501 N. Saint Vincent St. | Tampa | FL | 33614 | Concrete Driveways, Sidew | 900972890 | MBE | Hispanic American |
| 4 | Sunrise Utility Construction, Inc. | 813-949-3749 | 813-949-0408 | lmbn055@AOL.COM | P. O. Box 27293 | Tampa | FL | 33688 | Concrete Driveways, Sidew | 8993034012 | WBE | Caucasian |
| 5 | AI GENERAL CONSTRUCTION SERVICES INC | 813-391-5783 | | irma@aigeneralconstruct.com | 5415 SHAKESPEAR DR | DOVER | FL | 33527 | Roadway Restoration | 820821263 | MBE | Hispanic American |
| 5 | Blacktip Services, Inc. | 954-324-5300 | 321-285-2995 | blacktipemail@yahoo.com | 52 RILEY RD STE 422 | CELEBRATION | FL | 34747 | Roadway Restoration | 274431832 | WBE | Caucasian |
| 5 | Mill N Clean LLC | 727-514-2565 | | Kelly@millclean.com | 595 Ranch Road | Tarpon Springs | FL | 34688 | Roadway Restoration | 872232850 | WBE | Caucasian |
| 5 | Pavemaster Asphalt Paving LLC | 813-671-7300 | 813-671-7311 | Renae@pavemasterfl.com | PO Box 1345 | Gibsonton | FL | 33534 | Roadway Restoration | 830708817 | WBE | Caucasian |
| 6 | Baron's Landscaping Services, Inc. | 813-404-1509 | 813-443-4919 | baronslwicare@aol.com | 1704 N Riverhills Drive | TEMPLE TERRAC | FL | 33617 | Landscapes&Restoration | 850837654 | MBE | Hispanic American |
| 6 | Bay to Bay Environmental LLC | 813-343-3803 | | dieb@baytobayenvironmental.com | 9605 N. Hartis Dr. | Tampa | FL | 33617 | Landscapes&Restoration | 8993798117 | MBE | Hispanic American |
| 6 | D & J LAWN SERVICES OF LAKELAND LLC | 863-859-3525 | | DANDJLAWNSERVICES@HOTMAIL.COM | 575 Old Poik City Road | Lakeland | FL | 33809 | Landscapes&Restoration | 273279070 | MBE | Hispanic American |
| 6 | Florida Natives Nursery, Inc. | 813-754-1900 | 813-754-4001 | office@floridanativesnursery.com | 4115 NATIVE GARDEN DR | PLANT CITY | FL | 33565 | Landscapes&Restoration | 8993561539 | WBE | Caucasian |
| 6 | JTCM Inc | 813-935-7724 | | office@lawnsculptures.net | 817 S MacDill Ave | Tampa | FL | 33609 | Landscapes&Restoration | 962418914 | WBE | Caucasian |
| 6 | Landscapes Maintenance Professionals, Inc. | 813-757-6501 | | kimberly.martinez33@gmail.com | 13050 E US Highway 92 | Dover | FL | 33527 | Landscapes&Restoration | 8993613665 | MBE | Hispanic American |
| 6 | Nelson's Tree Farm and Nursery, Inc. | 813-842-4663 | 813-350-9139 | janet@pinelakenurseryinc.com | 5027 N Lois Ave | Tampa | FL | 33614 | Landscapes&Restoration | 8993404710 | MBE | Hispanic American |
| 6 | Pine Lake Nursery & Landscaping, Inc. | 813-948-4736 | 813-948-4914 | janet@pinelakenurseryinc.com | 2122 Henley Rd | Lutz | FL | 33558 | Landscapes&Restoration | 8993499734 | MBE | Hispanic American |
| 6 | Sunbelt Sod & Grading Company | 813-641-9855 | | social@amediamarketing.com | 819 - 9th St. N.E. | Ruskin | FL | 33570 | Landscapes&Restoration | 834250933 | WBE | Caucasian |
| 7 | A Business Forms & Pegboard Systems, Inc. | 813-933-2788 | | diamantdevelopmentllc@gmail.com | 3104 North Armenia Avenue, Suite 2 | Tampa | FL | 33607 | Video | 8131559977 | WBE | Caucasian |
| 7 | Diamond Development LLC | 352-551-3194 | | diamantdevelopmentllc@gmail.com | 905 Spring Valley Rd | Altamonte Sprin | FL | 32714 | Video | 813746486 | WBE | Caucasian |
| 7 | JML Advertising, Inc. | 407-353-6782 | | Kathy.Kahan@aol.com | 550 Birdsong Court | Longwood | FL | 32779 | Video | 8993750544 | WBE | Caucasian |
| 7 | LP Video Productions, Inc. | 407-896-9727 | 866-702-5438 | laurie@lp-video.com | 181 Elsa Street | Orlando | FL | 32806 | Video | 8993556752 | WBE | Caucasian |
| 8 | B & E Signal and Lighting Inc. | 941-758-3594 | 941-758-3805 | nisa@beutility.com | 6447 33RD ST E | SARASOTA | FL | 34243 | Maintenance of Traffic | 202880417 | MBE | Asian American |
| 8 | Beato Group, Inc. | 813-252-0196 | | Info@BeatoGroup.com | 8961 Turnstone Haven Place | Tampa | FL | 33619 | Maintenance of Traffic | 854003966 | MBE | Hispanic American |
| 8 | Bussey Construction Services, Inc. | 813-857-3844 | | kbussay@busseyconstruction.com | 32234 Summerglade Dr | Wesley Chapel | FL | 33545 | Maintenance of Traffic | 864643333 | WBE | Caucasian |
| 8 | M.P.G. & Company, Inc. | 727-518-1761 | 727-518-1751 | mpg8949@aol.com | 8949 131ST PLACE NORTH | LARGO | FL | 33773 | Maintenance of Traffic | 8993143615 | WBE | Caucasian |
| 8 | MOTPLANS.COM | 813-600-7884 | 954-759-9186 | SATTYA@MOTPLANS.COM | 4928 Old Winter Garden Road | Orlando | FL | 32811 | Maintenance of Traffic | 760742303 | MBE | Asian American |
| 8 | TRAFFIC CONTROL PRODUCTS OF FLORIDA INC | 813-621-8484 | 813-621-4611 | kw@trafficcontrolproducts.org | 5514 CARMACK RD | TAMPA | FL | 33610 | Maintenance of Traffic | 892582822 | WBE | Caucasian |
| 8 | USA Protek LLC | 863-944-1422 | | dstengel@usaprotek.com | 2404 Crews Lake Hills Ln N | Lakeland | FL | 33813 | Maintenance of Traffic | 872299161 | WBE | Caucasian |

Instructions Regarding Use of the WMBE/SLBE Availability Contact List

Bidders must solicit a subcontracting bid from ALL of the firms listed on the WMBE/SLBEs list provided within the Specifications, and provide documentation of emails, faxes, phone calls, letters, or other communication with the firms as a first step in demonstrating Good-Faith Efforts to achieve the goal set for WMBE/SLBE participation on this contract.

The list is formatted to facilitate e-mailing of a solicitation to the listed firms by copying and pasting the email addresses.

The WMBE/SLBE participation Goal is based upon the availability of the certified firms indicated on the contact list. The Goal and Requirements of the City's Equal Business Opportunity Program are stated in the Bid/Contract Document, Specifications.

PROPOSAL

To the Mayor and City Council of the City of Tampa, Florida:

Legal Name of Bidder: _____

Bidder's Fictitious Name, if applicable: _____

Bidder is a/an: Individual Partnership* Joint Venture* LLC Corp. Other:

Bidder is organized under the laws of: State of Florida Other:

Bidder Mailing Address: _____

Bidder's Federal Employee Identification No. (FEI/EIN): _____

Bidder's License No.: _____ Bidder's FDOS (SUNBIZ) Doc. No.: _____
(See Ch. 489. FS; use entity's, individual's only if applicable)

Bidder Contact Name**: _____ Email: _____ Phone: (____) _____

Bidder's own initial application for employment has criminal history screening practices similar in nature to the practices contained in Chapter 12, Article VI, City of Tampa Code (*Responses, whether "Yes" or "No", are for informational purposes only and will not be used as a basis of award or denial, nor as a basis for any protest*): Yes No

The below named person, appearing before the undersigned authority and after being first duly sworn, for him/herself and on behalf of the entity submitting this Proposal does hereby affirm and declare as follows:

- (1) He/She is of lawful age and is authorized to act on behalf of Bidder (the individual, partnership, corporation, entity, etc. submitting this Proposal) and that all statements made in this document are true and correct to the best of my knowledge.
- (2) If Bidder is operating under a fictitious name, Bidder has currently complied with any and all laws and procedures governing the operation of businesses under fictitious names in the State of Florida
- (3) No person or entity other than Bidder has any interest in this Proposal or in the Contract proposed to be entered into.
- (4) This Proposal is made without any understanding, agreement, or connection with any person or entity making Proposal for the same purposes, and is in all respects fair and without collusion or fraud.
- (5) Bidder is not in arrears to the City of Tampa, upon debt or contract, and is not a defaulter, as surety or otherwise, upon any obligation to the City of Tampa.
- (6) That no officer or employee or person whose salary is payable in whole or in part from the City Treasury is, shall be or become interested, directly or indirectly, as a contracting party, partner, stockholder, surety or otherwise, in this Proposal, or in the performance of the Contract, or in the supplies, materials, or equipment and work or labor to which it relates, or in any portion of the profits thereof.
- (7) Bidder has carefully examined and fully understands the Solicitation and has full knowledge of the scope, nature, and quality of the work to be performed; furthermore, Bidder has carefully examined the site of the work and that, from his own investigations, he has satisfied himself as to the nature and location of the work, the character, quality, and quantity of materials and the kinds and extent of equipment and other facilities needed for the performance of the work, the general and local conditions and all difficulties to be encountered, and all other items which may, in any way, affect the work or its performance.
- (8) Bidder (including its principals) has | has NOT been debarred or suspended from contracting with a public entity.
- (9) Bidder has | has NOT implemented a drug-free workplace program that meets the requirements of Section 287.087, Florida Statutes.
- (10) Bidder has carefully examined and fully understands all the component parts of the Contract Documents and agrees Bidder will execute the Contract, provide the required Public Construction Bond, and will fully perform the work in strict accordance with the terms of the Contract and Contract Documents therein referred to for the following prices, to wit:

* If a Partnership or Joint Venture, attach Partnership or Joint Venture Agreement.

** Someone the City may contact with questions/correspondence regarding this Solicitation and/or permits.

**Contract 22-C-00034
Citywide Meter, Hydrant, and Valve Installation and Replacement - FY2022**

| Item No. | Description | Unit | Quantity | Unit Price in Words | Unit Price | Total Computed Price |
|----------|---|------|----------|---------------------|------------|----------------------|
| 2100 | F&I 4" ductile iron pipe | LF | 200 | | \$ | \$ |
| 2102 | F&I 6" ductile iron pipe | LF | 1,000 | | \$ | \$ |
| 2104 | F&I 8" ductile iron pipe | LF | 500 | | \$ | \$ |
| 2105 | F&I 10" ductile iron pipe | LF | 100 | | \$ | \$ |
| 2106 | F&I 12" ductile iron pipe | LF | 200 | | \$ | \$ |
| 2108 | F&I 16" ductile iron pipe | LF | 200 | | \$ | \$ |
| 2149 | F&I 2" PVC pipe and fittings at various depths | LF | 500 | | \$ | \$ |
| 2150 | F&I 4" PVC pipe | LF | 100 | | \$ | \$ |
| 2152 | F&I 6" PVC pipe | LF | 1,000 | | \$ | \$ |
| 2154 | F&I 8" PVC pipe | LF | 500 | | \$ | \$ |
| 2156 | F&I 12" PVC pipe | LF | 100 | | \$ | \$ |
| 2158 | F&I 16" PVC pipe | LF | 100 | | \$ | \$ |
| 2200 | F&I 2" HDPE w/HDPE transitions adapters at various depths | LF | 500 | | \$ | \$ |
| 2201 | F&I 4" HDPE pipe by HDD at various depths | LF | 100 | | \$ | \$ |
| 2202 | F&I 6" HDPE pipe by HDD at various depths | LF | 500 | | \$ | \$ |
| 2203 | F&I 8" HDPE pipe by HDD at various depths | LF | 100 | | \$ | \$ |
| 2300 | Furnish, install and remove 2-inch temporary service line | LF | 200 | | \$ | \$ |
| 2500 | Removal of abandoned pipe 3" and smaller in diameter | LF | 2 | | \$ | \$ |
| 2501 | Removal of abandoned pipe 4" - 10" in diameter | LF | 2 | | \$ | \$ |
| 2600 | Cut and plug 3" and smaller in diameter pipe, to include meter services lines | EA | 300 | | \$ | \$ |
| 2601 | Cut and plug 4", 6" and 8" diameter pipe | EA | 10 | | \$ | \$ |
| 2602 | Cut and plug 10", 12" and 16" diameter pipe | EA | 5 | | \$ | \$ |
| 2800 | Make tap and furnish materials to connect 3" and smaller water mains to new/existing mains (0-15 ft. in length) | EA | 5 | | \$ | \$ |
| 2801 | Make tap and furnish materials to connect 3" and smaller water mains to new/existing mains (more than 15 ft. in length) | EA | 5 | | \$ | \$ |
| 3000 | F&I 4" wedge-action MJ or flange restraint | EA | 10 | | \$ | \$ |
| 3001 | F&I 6" wedge-action MJ or flange restraint | EA | 10 | | \$ | \$ |
| 3002 | F&I 8" wedge-action MJ or flange restraint | EA | 10 | | \$ | \$ |
| 3003 | F&I 10" wedge-action MJ or flange restraint | EA | 10 | | \$ | \$ |
| 3004 | F&I 12" wedge-action MJ or flange restraint | EA | 10 | | \$ | \$ |
| 3005 | F&I 14" wedge-action MJ or flange restraint | EA | 10 | | \$ | \$ |
| 3006 | F&I 16" wedge-action MJ or flange restraint | EA | 10 | | \$ | \$ |
| 3040 | Furnish & install 4" bell and MJ restraint on existing pipe | EA | 6 | | \$ | \$ |
| 3041 | Furnish & install 6" bell and MJ restraint on existing pipe | EA | 20 | | \$ | \$ |
| 3042 | Furnish & install 8" bell and MJ restraint on existing pipe | EA | 20 | | \$ | \$ |
| 3043 | Furnish & install 10" bell and MJ restraint on existing pipe | EA | 20 | | \$ | \$ |
| 3044 | Furnish & install 12" bell and MJ restraint on existing pipe | EA | 20 | | \$ | \$ |
| 3045 | Furnish & install 16" bell and MJ restraint on existing pipe | EA | 10 | | \$ | \$ |
| 3050 | Furnish & install 4" wedge-action MJ restraint on new PVC pipe | EA | 10 | | \$ | \$ |
| 3051 | Furnish & install 6" wedge-action MJ restraint on new PVC pipe | EA | 10 | | \$ | \$ |
| 3052 | Furnish & install 8" wedge-action MJ restraint on new PVC pipe | EA | 10 | | \$ | \$ |
| 3053 | Furnish & install 12" wedge-action MJ restraint on new PVC pipe | EA | 10 | | \$ | \$ |
| 3054 | Furnish & install 16" wedge-action MJ restraint on new PVC pipe | EA | 10 | | \$ | \$ |
| 3070 | Furnish 4" push-on gasket (gripper-type) restraint | EA | 30 | | \$ | \$ |
| 3071 | Furnish 6" push-on gasket (gripper-type) restraint | EA | 30 | | \$ | \$ |
| 3072 | Furnish 8" push-on gasket (gripper-type) restraint | EA | 30 | | \$ | \$ |
| 3073 | Furnish 12" push-on gasket (gripper-type) restraint | EA | 30 | | \$ | \$ |
| 3074 | Furnish 16" push-on gasket (gripper-type) restraint | EA | 30 | | \$ | \$ |
| 4000 | F&I 4" DI MJ plug or cap | EA | 2 | | \$ | \$ |
| 4001 | F&I 4" DI MJ bend, offset, sleeve or reducer | EA | 2 | | \$ | \$ |

**Contract 22-C-00034
Citywide Meter, Hydrant, and Valve Installation and Replacement - FY2022**

| Item No. | Description | Unit | Quantity | Unit Price in Words | Unit Price | Total Computed Price |
|----------|--|------|----------|---------------------|------------|----------------------|
| 4002 | F&I 4" DI MJ tee | EA | 2 | | \$ | \$ |
| 4003 | F&I 4" (x 12") DI MJ offset | EA | 2 | | \$ | \$ |
| 4004 | F&I 6" DI MJ plug or cap | EA | 2 | | \$ | \$ |
| 4005 | F&I 6" DI MJ bend, offset, sleeve or reducer | EA | 10 | | \$ | \$ |
| 4006 | F&I 6" DI MJ tee | EA | 5 | | \$ | \$ |
| 4007 | F&I 6" (x 12") DI MJ offset | EA | 2 | | \$ | \$ |
| 4008 | F&I 8" DI MJ plug or cap | EA | 2 | | \$ | \$ |
| 4009 | F&I 8" DI MJ bend, offset, sleeve or reducer | EA | 10 | | \$ | \$ |
| 4010.1 | F&I 8" x 4" DI MJ tee | EA | 2 | | \$ | \$ |
| 4010.2 | F&I 8" x 6" DI MJ tee | EA | 2 | | \$ | \$ |
| 4010.3 | F&I 8" x 8" DI MJ tee | EA | 2 | | \$ | \$ |
| 4011 | F&I 8" (x 12") DI MJ offset | EA | 2 | | \$ | \$ |
| 4012 | F&I 12" DI MJ plug or cap | EA | 2 | | \$ | \$ |
| 4013 | F&I 12" DI MJ sleeve or reducer | EA | 2 | | \$ | \$ |
| 4013.1 | F&I 12" DI MJ 11.25°(or 22.5°) bend | EA | 2 | | \$ | \$ |
| 4013.2 | F&I 12" 45° DI MJ bend | EA | 2 | | \$ | \$ |
| 4013.3 | F&I 12" 90° DI MJ bend | EA | 2 | | \$ | \$ |
| 4014.1 | F&I 12" x 4" (or 6") DI MJ tee | EA | 2 | | \$ | \$ |
| 4014.2 | F&I 12" x 8" DI MJ tee | EA | 2 | | \$ | \$ |
| 4014.3 | F&I 12" x 12" DI MJ tee | EA | 2 | | \$ | \$ |
| 4015 | F&I 12" (x 12") DI MJ offset | EA | 2 | | \$ | \$ |
| 4016 | F&I 16" MJ DI MJ plug or cap | EA | 2 | | \$ | \$ |
| 4017 | F&I 16" DI MJ sleeve or reducer | EA | 2 | | \$ | \$ |
| 4017.1 | F&I 16" DI MJ 11.25° bend | EA | 2 | | \$ | \$ |
| 4017.2 | F&I 16" 22.5° DI MJ bend | EA | 2 | | \$ | \$ |
| 4017.3 | F&I 16" 45° DI MJ bend | EA | 2 | | \$ | \$ |
| 4017.4 | F&I 16" 90° DI MJ bend | EA | 2 | | \$ | \$ |
| 4018.1 | F&I 16" x 4" (or 6") DI MJ tee | EA | 2 | | \$ | \$ |
| 4018.2 | F&I 16" x 8" DI MJ tee | EA | 2 | | \$ | \$ |
| 4018.3 | F&I 16" x 12" DI MJ tee | EA | 2 | | \$ | \$ |
| 4018.4 | F&I 16" x 16" DI MJ tee | EA | 2 | | \$ | \$ |
| 4019 | F&I 16" (x 12") DI MJ offset | EA | 2 | | \$ | \$ |
| 5000 | (valve, tee/tap, and Gradelok fitting paid separate) | EA | 30 | | \$ | \$ |
| 5010 | F&I 6" Gradelok fitting with FH installation | EA | 4 | | \$ | \$ |
| 5011 | F&I 12" Gradelok fitting with FH installation | EA | 4 | | \$ | \$ |
| 5012 | F&I 24" Gradelok fitting with FH installation | EA | 4 | | \$ | \$ |
| 5101 | Remove & salvage Fire Hydrant Assembly | EA | 20 | | \$ | \$ |
| 5300 | F&I Protection Post | EA | 2 | | \$ | \$ |
| 6000 | F&I 2" gate or tapping valve with box | EA | 2 | | \$ | \$ |
| 6001 | F&I 4" gate or tapping valve with box | EA | 2 | | \$ | \$ |
| 6002 | F&I 6" gate or tapping valve with box | EA | 30 | | \$ | \$ |
| 6003 | F&I 8" gate or tapping valve with box | EA | 20 | | \$ | \$ |
| 6004 | F&I 10" gate or tapping valve with box | EA | 2 | | \$ | \$ |
| 6005 | F&I 12" gate or tapping valve with box | EA | 2 | | \$ | \$ |
| 6006 | F&I 16" gate or tapping valve with box | EA | 2 | | \$ | \$ |
| 6020 | F&I 16" butterfly valve with box | EA | 2 | | \$ | \$ |
| 6080 | F&I Valve Nut Extension | EA | 4 | | \$ | \$ |
| 6200 | F&I 2" or 2-1/2" Linestop on Water Main | EA | 1 | | \$ | \$ |
| 6201 | F&I 4" Linestop on Water Main | EA | 1 | | \$ | \$ |

**Contract 22-C-00034
Citywide Meter, Hydrant, and Valve Installation and Replacement - FY2022**

| Item No. | Description | Unit | Quantity | Unit Price in Words | Unit Price | Total Computed Price |
|----------|--|-------|----------|---------------------|------------|----------------------|
| 6203 | F&I 6" Linestop on Water Main | EA | 6 | | \$ | \$ |
| 6205 | F&I 8" Linestop on Water Main | EA | 6 | | \$ | \$ |
| 6207 | F&I 10" Linestop on Water Main | EA | 1 | | \$ | \$ |
| 6208 | F&I 12" Linestop on Water Main | EA | 4 | | \$ | \$ |
| 6209 | F&I 16" Linestop on Water Main | EA | 4 | | \$ | \$ |
| 6210 | F&I 24" Linestop on Water Main | EA | 2 | | \$ | \$ |
| 6211 | F&I 30" Linestop on Water Main | EA | 1 | | \$ | \$ |
| 6212 | F&I 36" Linestop on Water Main | EA | 1 | | \$ | \$ |
| 7001.0 | F&I 4" MJ tapping sleeve and make tap | EA | 1 | | \$ | \$ |
| 7001.1 | F&I 6" x 4" Steel tapping sleeve and make tap | EA | 5 | | \$ | \$ |
| 7001.2 | F&I 6" x 6" MJ tapping sleeve and make tap | EA | 10 | | \$ | \$ |
| 7002.1 | F&I 8" x 4" Steel tapping sleeve and make tap | EA | 1 | | \$ | \$ |
| 7002.2 | F&I 8" x 6" Steel tapping sleeve and make tap | EA | 10 | | \$ | \$ |
| 7002.3 | F&I 8" x 8" MJ tapping sleeve and make tap | EA | 4 | | \$ | \$ |
| 7003.1 | F&I 12" x 4" Steel tapping sleeve and make tap | EA | 1 | | \$ | \$ |
| 7003.2 | F&I 12" x 6" Steel tapping sleeve and make tap | EA | 10 | | \$ | \$ |
| 7003.3 | F&I 12" x 8" Steel tapping sleeve and make tap | EA | 2 | | \$ | \$ |
| 7003.4 | F&I 12" x 12" MJ tapping sleeve and make tap | EA | 1 | | \$ | \$ |
| 7004.1 | F&I 16" x (≤8") Steel tapping sleeve and make tap | EA | 1 | | \$ | \$ |
| 7004.2 | F&I 16" x 12" Steel tapping sleeve and make tap | EA | 1 | | \$ | \$ |
| 7004.3 | F&I 16" x 16" MJ tapping sleeve and make tap | EA | 1 | | \$ | \$ |
| 8100 | F&I 3/4" or 1" meter service (0-15') | EA | 300 | | \$ | \$ |
| 8101 | F&I 3/4" meter service (+15-80') | EA | 300 | | \$ | \$ |
| 8102 | F&I 3/4" meter service (+80-150') | EA | 10 | | \$ | \$ |
| 8103 | F&I 3/4" or 1" Dual meter service (0 - 15') | EA | 10 | | \$ | \$ |
| 8104 | F&I 3/4" or 1" Dual meter service (+15'-80') | EA | 10 | | \$ | \$ |
| 8105 | F&I 3/4" Dual meter service (+80'-150') | EA | 10 | | \$ | \$ |
| 8106 | F&I 1" Dual meter service (+80'-150') | EA | 10 | | \$ | \$ |
| 8107 | F&I 1" or 1-1/2" meter service (+15'-80') | EA | 10 | | \$ | \$ |
| 8108 | F&I 1" or 1-1/2" meter service (+80'-150') | EA | 10 | | \$ | \$ |
| 8109 | F&I 1-1/2" or 2" meter service (0-15') | EA | 10 | | \$ | \$ |
| 8110 | F&I 2" DDCV and service (0-15') | EA | 10 | | \$ | \$ |
| 8300 | Install city-provided 3" meter (slab or vault to be paid separate) | EA | 5 | | \$ | \$ |
| 8301 | Install city-provided 4" meter (slab or vault to be paid separate) | EA | 5 | | \$ | \$ |
| 8302 | Install city-provided 6" meter (slab or vault to be paid separate) | EA | 3 | | \$ | \$ |
| 8303 | Install city-provided 8" meter (slab or vault to be paid separate) | EA | 3 | | \$ | \$ |
| 8320 | Install 4" double detector check valve assembly | EA | 1 | | \$ | \$ |
| 8321 | Install 6" double detector check valve assembly | EA | 1 | | \$ | \$ |
| 8322 | Install 8" double detector check valve assembly | EA | 1 | | \$ | \$ |
| 8323 | Install 10" double detector check valve assembly | EA | 1 | | \$ | \$ |
| 8324 | Install 12" double detector check valve assembly | EA | 1 | | \$ | \$ |
| 8404 | F&I auxiliary materials for above-ground large service w/ 12x5' slab | EA | 1 | | \$ | \$ |
| 8405 | F&I auxiliary materials for above-ground large service w/ 12x9' slab | EA | 1 | | \$ | \$ |
| 9200 | Furnish, place and compact limerock base | CY | 50 | | \$ | \$ |
| 9201 | Furnish, place and compact crushed concrete base | CY | 100 | | \$ | \$ |
| 9202 | Furnish and place approved flowable fill | CY | 100 | | \$ | \$ |
| 9203 | Furnish, place and compact asphalt patch (Superpave Type SP 12.5 or Type SP 9.5 w/ < 8 SY or < 1.5 Tons) | SY-IN | 500 | | \$ | \$ |
| 9205 | Furnish, place and compact asphalt concrete base or surface course, (Superpave Type SP-12.5) | TN | 50 | | \$ | \$ |
| 9207 | Furnish, place, grade and compact asphaltic concrete overlay (Superpave Type SP-9.5) | TN | 50 | | \$ | \$ |

**Contract 22-C-00034
Citywide Meter, Hydrant, and Valve Installation and Replacement - FY2022**

| Item No. | Description | Unit | Quantity | Unit Price in Words | Unit Price | Total Computed Price |
|--------------|---|-----------|-----------|---|----------------------|----------------------|
| 9208 | Mobilization to perform mechanical milling | EA | 4 | | \$ | |
| 9209 | Mechanical milling of asphalt roadways in 1-inch increments | SY-IN | 1,000 | | \$ | |
| 9210 | Restore 6" thick concrete driveway | SY | 200 | | \$ | |
| 9211 | Restore brick pavement, including base material | SY | 20 | | \$ | |
| 9212 | Install Brick pavement furnished by City, Contractor F&I base material | SY | 100 | | \$ | |
| 9250 | Furnish materials & Install Signalization loops | EA | 5 | | \$ | |
| 9300 | Furnish and install Type "D" concrete curb | LF | 100 | | \$ | |
| 9301 | Furnish and install valley curb | LF | 20 | | \$ | |
| 9302 | Furnish and install Miami curb | LF | 100 | | \$ | |
| 9303 | Furnish and install Type "F" concrete curb | LF | 100 | | \$ | |
| 9304 | Furnish and install stone or precast curb | LF | 20 | | \$ | |
| 9305 | Remove and install existing stone curb | LF | 10 | | \$ | |
| 9306 | Furnish and install asphaltic concrete curb | LF | 10 | | \$ | |
| 9307 | Furnish and install 4" thick concrete sidewalk | SY | 300 | | \$ | |
| 9308 | Furnish and install paver block sidewalk or driveway | SY | 50 | | \$ | |
| 9309 | Grade and sod roadside/ditch bottoms and sides - Bahia | SY | 1,000 | | \$ | |
| 9310 | Grade and sod roadside/ditch bottoms & sides - St. Augustine | SY | 1,000 | | \$ | |
| 9311 | Grade, fertilize, sprig, and hydro-seed roadside | SY | 50 | | \$ | |
| 9312 | F&I detectable warnings on concrete walking surfaces | EA | 6 | | \$ | |
| 9400 | Grout abandoned pipe | CY | 2 | | \$ | |
| 9410 | Place and compact backfill soils | CY | 2 | | \$ | |
| 9411 | Furnish, place and compact backfill soils | CY | 2 | | \$ | |
| 9500 | Furnish, form and place reinforced concrete | CY | 2 | | \$ | |
| 9504 | Replace damaged but not marked sanitary laterals, w PVC | LF | 50 | | \$ | |
| 9505 | Video photography | LF | 100 | | \$ | |
| 9600 | Demolish and Remove Large service vault | EA | 1 | | \$ | |
| 9601 | Demolish and Remove Large service concrete slab | EA | 1 | | \$ | |
| 9701 | Excavation and removal of muck | CY | 2 | | \$ | |
| 9801 | Root Pruning | LF | 20 | | \$ | |
| 9900 | Excavation exploratory pits (10'x10' x 5' deep) | EA | 10 | Six Hundred Fifty Dollars and No Cents | \$ 650.00 | 6,500.00 |
| 9920 | F&I blow-off assembly w/valve & meter box, per Detail 2.16 | EA | 5 | | \$ | |
| 9921 | F&I blow-off assembly w/valve & meter box, per Detail 2.17 | EA | 5 | | \$ | |
| 9930 | Furnish & install precast thrust blocks | EA | 6 | | \$ | |
| 9931 | Furnish, form & pour concrete thrust blocks | CY | 1 | | \$ | |
| 9940 | Cut into existing asbestos concrete pipe | EA | 1 | | \$ | |
| 9980 | Contingency allowance - to be used by City | LS | 1 | Three Hundred Seventy Five Thousand Dollars and No Cents | \$ 375,000.00 | 375,000.00 |
| 10000 | Payment and Performance Bond Allowance | LS | 1 | Sixty Five Thousand Dollars and No Cents | \$ 65,000.00 | 65,000.00 |
| 11000 | Maintenance of Traffic Allowance (3% of Work Order or cost-markup) | LS | 1 | Two Hundred Fifty Thousand Dollars and No Cents | \$ 250,000.00 | 250,000.00 |
| | | | | TOTAL | | |

Computed Total Price in Words: _____
 _____ dollars and _____ cents.

Computed Total Price in Figures: \$ _____

Bidder acknowledges that the following addenda have been received and that the changes covered by the addendum(s) have been taken into account in this proposal: #1 ____ #2 ____ #3 ____ #4 ____ #5 ____ #6 ____ #7 ____ #8 ____.

Bidder acknowledges the requirements of the City of Tampa's Equal Business Opportunity Program.

Bidder acknowledges that it is aware of Florida's Trench Safety Act (Sections 553.60-553.64, Florida Statutes), and agrees that Bidder together with any involved subcontractors will comply with all applicable trench safety standards. Bidder further acknowledges that included in the various items of this Proposal and the total bid price (as applicable) are costs for complying with the Trench Safety Act. Bidder further identifies the costs and methods summarized below:

| | Trench Safety Measure (Description) | Unit of Measure (LF, SY) | Unit Quantity | Unit Cost | Extended Cost |
|-----------------------|--|-------------------------------------|--------------------------|----------------------|--------------------------|
| A. | _____ | _____ | _____ | _____ | _____ |
| B. | _____ | _____ | _____ | _____ | _____ |
| C. | _____ | _____ | _____ | _____ | _____ |
| Total Cost: \$ | | | | _____ | |

Accompanying this Proposal is a certified check, cashier's check or Tampa Bid Bond (form included herein must be used) for at least five percent (5%) of the total amount of the Proposal which check shall become the property of the City, or which bond shall become forthwith due and payable to the City, if this Proposal shall be accepted by the City and the Bidder shall fail to enter into a legally binding contract with and to furnish the required Public Construction Bond to the City within twenty (20) days after the date of its receipt of written Notice of Award by the City so to do.

FAILURE TO COMPLETE THE ABOVE MAY RESULT IN THE PROPOSAL BEING DECLARED NON-RESPONSIVE.

[SEAL] Name of Bidder: _____
 Authorized Signature: _____
 Signer's Printed Name: _____
 Signer's Title: _____

STATE OF _____
 COUNTY OF _____

For an entity: The forgoing instrument was sworn (or affirmed) before me this ____ day of _____, 20____ by _____ as _____ of _____, a/n Partnership Joint Venture LLC Corp Other: _____, on behalf of such entity. Such individual is personally known to me or produced a/n _____ state driver's license as identification.

For an individual: The forgoing instrument was sworn (or affirmed) before me this ____ day of _____, 20____ by _____, who is personally known to me or produced a/n _____ state driver's license as identification.

[NOTARY SEAL] Notary Public, State of _____
 Notary Printed Name: _____
 Commission No.: _____
 My Commission Expires: _____



Good Faith Effort Compliance Plan Guidelines

for Women/Minority Business Enterprise/Small Local Business Enterprise Participation
City of Tampa - Equal Business Opportunity Program
(MBD Form 50 – detailed instructions on page 2 of 2)

Contract Name _____ Bid Date _____

Bidder/Proposer _____

Signature _____ Date _____

Name _____ Title _____

The Compliance Plan with attachments is a true account of Good Faith Efforts (GFE) made to achieve the participation goals as specified for Women/Minority Business Enterprises/Small Local Business Enterprises (WMBE/SLBE) on the referenced contract:

The WMBE/SLBE participation **Goal is Met or Exceeded**. See DMI Forms 10 and 20 which accurately report all subcontractors solicited and all subcontractors to-be-utilized.

The WMBE/SLBE participation Goal is **Not Achieved**. The following list is an overview of the baseline GFE action steps already performed. Furthermore, it is understood that these GFE requirements are weighted in the compliance evaluation based on the veracity and demonstrable degree of documentation provided with the bid/proposal:

(Check applicable boxes below. Must enclose supporting documents accordingly with remarks)

- (1) Solicited through reasonable and available means the interest of WMBE/SLBEs that have the capability to perform the work of the contract. The Bidder or Proposer must solicit this interest within sufficient time to allow the WMBE/SLBEs to respond. The Bidder or Proposer must take appropriate steps to follow up initial solicitations with interested WMBE/SLBEs. See DMI report forms for subcontractors solicited. See enclosed supplemental data on solicitation efforts. Qualifying Remarks:
- (2) Provided interested WMBE/SLBEs with adequate, specific scope information about the plans, specifications, and requirements of the contract, including addenda, in a timely manner to assist them in responding to the requested-scope identified by bidder/proposer for the solicitation. See enclosed actual solicitations used. Qualifying Remarks:
- (3) Negotiated in good faith with interested WMBE/SLBEs that have submitted bids (e.g. adjusted quantities or scale). Documentation of negotiation must include the names, addresses, and telephone numbers of WMBE/SLBEs that were solicited; the date of each such solicitation; a description of the information provided regarding the plans and specifications for the work selected for subcontracting; and evidence as to why agreements could not be reached with WMBE/SLBEs to perform the work. Additional costs involved in soliciting and using subcontractors is not a sufficient reason for a bidder/proposer's failure to meet goals or achieve participation, as long as such costs are reasonable. Bidders are not required to accept excessive quotes in order to meet the goal. DMI Utilized Forms for sub-(contractor/consultant) reflect genuine negotiations This project is an RFO/RFP in nature and negotiations are limited to clarifications of scope/specifications and qualifications. See enclosed documentation. Qualifying Remarks:
- (4) Not rejecting WMBE/SLBEs as being unqualified without justification based on a thorough investigation of their capabilities. The WMBE/SLBEs standing within its industry, membership in specific groups, organizations / associations and political or social affiliations are not legitimate causes for rejecting or not soliciting bids to meet the goals. Not applicable. See attached justification for rejection of a subcontractor's bid or proposal. Qualifying Remarks:
- (5) Made scope(s) of work available to WMBE/SLBE subcontractors and suppliers; and, segmented portions of the work or material consistent with the available WMBE/SLBE subcontractors and suppliers, so as to facilitate meeting the goal. Sub-Contractors were allowed to bid on their own choice of work or trade without restriction to a pre-determined portion. See enclosed comments. Qualifying Remarks:
- (6) Made good faith efforts, despite the ability or desire of Bidder/Proposer to perform the work of a contract with its own forces/organization. A Bidder/Proposer who desires to self-perform the work of a contract must demonstrate good faith efforts if the goal has not been met. Sub-Contractors were not prohibited from submitting bids/proposals and were solicited on work typically self-performed by the prime. Qualifying Remarks:
- (7) Segmented portions of the work to be performed by WMBE/SLBEs in order to increase the likelihood that the goals will be met. This includes, where appropriate, breaking out contract work items into economically feasible units (quantities/scale) to facilitate WMBE/SLBE participation, even when the Bidder/Proposer might otherwise prefer to perform these work items with its own forces. Sub-Contractors were allowed to bid on their own choice of work or trade without restriction to a pre-determined portion. Sub-Contractors were not prohibited from submitting bids/proposals and were solicited on work typically self-performed by the prime. See enclosed comments. Qualifying Remarks:
- (8) Made efforts to assist interested WMBE/SLBEs in obtaining bonding, lines of credit, or insurance as required by the city or contractor. See enclosed documentation on initiatives undertaken and methods to accomplish. Qualifying Remarks:
- (9) Made efforts to assist interested WMBE/SLBEs in obtaining necessary equipment, supplies, materials, or related assistance or services, including participation in an acceptable mentor-protégé program. See enclosed documentation of initiatives and/or agreements. Qualifying Remarks:
- (10) Effectively used the services of the City and other organizations that provide assistance in the recruitment and placement of WMBE/SLBEs. See enclosed documentation. The following services were used:

Note: Provide any unsolicited information that will support the Bid/RFP Compliance Evaluation. Named Documents Are:



Participation Plan: Guidance for Complying with Good Faith Efforts Outreach
(page 2 of 2)

1. All firms on the WMBE/SLBE Goal Setting List must be solicited and documentation provided for email, fax, letters, phone calls, and other methods of outreach/communication with the listed firms. The DMI Solicited and DMI-Utilized forms must be completed for all firms solicited or utilized. Other opportunities for subcontracting may be explored by consulting the City of Tampa MBD Office and/or researching the on-line Diversity Management Business System Directory for Tampa certified WMBE/SLBE firms.
2. Solicitation of WMBE/SLBEs, via written or electronic notification, should provide specific information on the services needed, where plans can be reviewed and assistance offered in obtaining these, if required. Solicitations should be sent a minimum of a week (i.e. 5 business days or more) before the bid/proposal date. Actual copies of the bidder's solicitation containing their scope specific instructions should be provided.
3. With any quotes received, a follow-up should be made when needed to confirm detail scope of work. For any WMBE/SLBE low quotes rejected, an explanation shall be provided detailing negotiation efforts.
4. If a low bid WMBE/SLBE is rejected or deemed unqualified the contractor must provide an explanation and supporting documentation for this decision.
5. Prime shall break down portions of work into economical feasible opportunities for subcontracting. The WMBE/SLBE directory may be useful in identifying additional subcontracting opportunities and firms not listed in the "WMBE/SLBE Goal Setting Firms List."
6. Contractor shall not preclude WMBE/SLBEs from bidding on any part of work, even if the Contractor may desire to self-perform the work.
7. Contractor shall avoid relying solely on subcontracting out work-scope where WMBE/SLBE availability is not sufficient to attain the pre-determined subcontract goal set for the Bid or when targeted sub-consultant participation is stated within the RFP/RFQ.
8. In its solicitations, the Bidder should offer assistance to WMBE/SLBEs in obtaining bonding, insurance, et cetera, if required of subcontractors by the City or Prime Contractor.
9. In its solicitation, the Bidder should offer assistance in obtaining equipment for a specific job to WMBE/SLBEs, if needed.
10. Contractor should use the services offered by such agencies as the City of Tampa Minority and Small Business Development Office, Hillsborough County Entrepreneur Collaborative Center, Hillsborough County Economic Development Department's MBE/SBE Program and the NAACP Empowerment Center to name a few for the recruitment and placement of WMBEs/SLBEs.



Failure to Complete, Sign and Submit Both Forms 10 & 20 SHALL render the Bid or Proposal Non-Responsive

**Page 1 of 4 – DMI Solicited/Utilized Schedules
City of Tampa – Schedule of **All Solicited** Sub-(Contractors/Consultants/Suppliers)
(FORM MBD-10)**

Contract No.: _____ Contract Name: _____
Company Name: _____ Address: _____
Federal ID: _____ Phone: _____ Fax: _____ Email: _____

Check applicable box(es). Detailed Instructions for completing this form are on page 2 of 4.

- No Firms were contacted or solicited for this contract.
- No Firms were contacted because: _____
- See attached list of additional Firms solicited and all supplemental information (List must comply to this form)
Note: Form MBD-10 must list ALL subcontractors solicited including Non-minority/small businesses

NIGP Code Categories: Buildings = 909, General = 912, Heavy = 913, Trades = 914, Architects = 906, Engineers & Surveyors = 925, Supplier = 912-77

| S = SLBE W=WMBE O = Neither | Company Name Address Phone, Fax, Email | Type of Ownership (F=Female M=Male) BF BM = African Am. HF HM = Hispanic AF AM = Asian Am. NF NM = Native Am. CF CM = Caucasian | Trade or Services NIGP Code (listed above) | Contact Method L=Letter F=Fax E=Email P=Phone | Quote or Response Received Y/N |
|-----------------------------------|--|---|--|--|--|
| | | | | | |
| | | | | | |
| | | | | | |
| | | | | | |
| | | | | | |
| | | | | | |
| | | | | | |
| | | | | | |
| | | | | | |
| | | | | | |
| | | | | | |
| | | | | | |
| | | | | | |
| | | | | | |
| | | | | | |
| | | | | | |
| | | | | | |
| | | | | | |
| | | | | | |

Failure to Complete, Sign and Submit
this form with your Bid or Proposal
Shall render the Bid Non-Responsive
(Do Not Modify This Form)

It is hereby certified that the information provided is an accurate and true account of contacts and solicitations for sub-contracting opportunities on this contract.

Signed: _____ Name/Title: _____ Date: _____

**Failure to Complete, Sign and Submit Both Forms 10 & 20 SHALL render the Bid or Proposal Non-Responsive
Forms must be included with Bid / Proposal**



Instructions for completing The Sub-(Contractors/Consultants/ Suppliers) Solicited Form (Form MBD-10)

This form must be submitted with all bids or proposals. All subcontractors (regardless of ownership or size) solicited and subcontractors from whom unsolicited quotations were received must be included on this form. The instructions that follow correspond to the headings on the form required to be completed. Note: Ability or desire to self-perform all work shall not exempt the prime from Good Faith Efforts to achieve participation.

- **Contract No.** This is the number assigned by the City of Tampa for the bid or proposal.
- **Contract Name.** This is the name of the contract assigned by the City of Tampa for the bid or proposal.
- **Contractor Name.** The name of your business and/or doing business as (dba) if applicable.
- **Address.** The physical address of your business.
- **Federal ID.** FIN. A number assigned to your business for tax reporting purposes.
- **Phone.** Telephone number to contact business.
- **Fax.** Fax number for business.
- **Email.** Provide email address for electronic correspondence.
- **No Firms were contacted or solicited for this contract.** Checking the box indicates that a pre-determined Subcontract Goal or Participation Plan Requirement was not set by the City resulting in your business not using subcontractors and will self-perform all work. If during the performance of the contract you employ subcontractors, the City must pre-approve subcontractors. Use of the “Sub-(Contractors/Consultants/Suppliers) Payments” form (MBD Form-30) must be submitted with every pay application and invoice. Note: Certified **SLBE or WMBE firms** bidding as Primes **are not exempt** from outreach and solicitation of subcontractors.
- **No Firms were contacted because.** Provide brief explanation why no firms were contacted or solicited.
- **See attached documents.** Check box, if after you have completed the DMI Form in its entirety, you need more space to list additional firms and/or if you have supplemental information/documentation relating to the form. All DMI data not submitted on the MBD Form-10 must be in the same format and have all requested data from MBD Form-10 included.

The following instructions are for information of any and all subcontractors solicited.

- **“S” = SLBE, “W” = WMBE.** Enter “S” for firms Certified by the City as Small Local Business Enterprises and/or “W” for firms Certified by the City as either Women/Minority Business Enterprise; **“O” = Non-certified others.**
- **Federal ID.** FIN. A number assigned to a business for tax reporting purposes. This information is critical in proper identification and payment of the contractor/subcontractor.
- **Company Name, Address, Phone & Fax.** Provide company information for verification of payments.
- **Type of Ownership.** Indicate the Ethnicity and Gender of the owner of the subcontracting business.
- **Trade, Services, or Materials** indicate the trade, service, or materials provided by the subcontractor. NIGP codes aka “National Institute of Governmental Purchasing” are listed at top section of document.
- **Contact Method L=letter, F=fax, E=Email, P=Phone.** Indicate with letter the method(s) of soliciting for bid.
- **Quote or Resp. (response) Rec’d (received) Y/N.** Indicate “Y” Yes if you received a quotation or if you received a response to your solicitation. Indicate “N” No if you received no response to your solicitation from the subcontractor. Must keep records: log, ledger, documentation, etc. that can validate/verify.

If additional information is required or you have questions, please contact the Equal Business Opportunity Program - Minority and Small Business Development Office at (813) 274-5522.



Failure to Complete, Sign and Submit Both Forms 10 & 20 SHALL render the Bid or Proposal Non-Responsive

Page 3 of 4 – DMI Solicited/Utilized Schedules
City of Tampa – Schedule of All To-Be-Utilized Sub-(Contractors/Consultants/Suppliers)
(FORM MBD-20)

Contract No.: _____ Contract Name: _____
Company Name: _____ Address: _____
Federal ID: _____ Phone: _____ Fax: _____ Email: _____

Check applicable box(es). Detailed Instructions for completing this form are on page 4 of 4.

See attached list of additional Firms Utilized and all supplemental information (List must comply to this form)

Note: Form MBD-20 must list ALL subcontractors To-Be-Utilized including Non-minority/small businesses

No Subcontracting/consulting (of any kind) will be performed on this contract.

No Firms are listed to be utilized because: _____

NIGP Code General Categories: Buildings = 909, General = 912, Heavy = 913, Trades = 914, Architects = 906, Engineers & Surveyors = 925, Supplier = 912-77

Enter "S" for firms Certified as Small Local Business Enterprises, "W" for firms Certified as Women/Minority Business Enterprise, "O" for Other Non-Certified

| S = SLBE W=WMBE O =Neither | Company Name Address Phone, Fax, Email | Type of Ownership (F=Female M=Male) BF BM = African Am. HF HM = Hispanic Am. AF AM = Asian Am. NF NM = Native Am. CF CM = Caucasian | Trade, Services, or Materials NIGP Code Listed above | \$ Amount of Quote. Letter of Intent (LOI) if available | Percent of Scope or Contract % |
|----------------------------------|--|---|---|---|--|
| | | | | | |
| | | | | | |
| | | | | | |
| | | | | | |
| | | | | | |
| | | | | | |
| | | | | | |
| | | | | | |
| | | | | | |
| | | | | | |
| | | | | | |
| | | | | | |
| | | | | | |
| | | | | | |
| | | | | | |
| | | | | | |
| | | | | | |
| | | | | | |
| | | | | | |
| | | | | | |

Failure to Complete, Sign and Submit
this form with your Bid or Proposal
Shall render the Bid Non-Responsive.
(Do Not Modify This Form)

Total ALL Subcontract / Supplier Utilization \$ _____
Total SLBE Utilization \$ _____
Total WMBE Utilization \$ _____
Percent SLBE Utilization of Total Bid/Proposal Amt. _____% Percent WMBE Utilization of Total Bid/Proposal Amt. _____%

It is hereby certified that the following information is a true and accurate account of utilization for sub-contracting opportunities on this Contract.

Signed: _____ Name/Title: _____ Date: _____

Failure to Complete, Sign and Submit Both Forms 10 & 20 SHALL render the Bid or Proposal Non-Responsive
Forms must be included with Bid / Proposal



Page 4 of 4 DMI – Solicited/**Utilized**

Instructions for completing **The Sub-(Contractors/Consultants/ Suppliers) to be Utilized Form (Form MBD-20)**

This form must be submitted with all bids or proposals. All subcontractors (regardless of ownership or size) projected to be utilized must be included on this form. Note: Ability or desire to self-perform all work shall not exempt the prime from Good Faith Efforts to achieve participation.

Contract No. This is the number assigned by the City of Tampa for the bid or proposal.

- **Contract Name.** This is the name of the contract assigned by the City of Tampa for the bid or proposal.
- **Contractor Name.** The name of your business and/or doing business as (dba) if applicable.
- **Address.** The physical address of your business.
- **Federal ID. FIN.** A number assigned to your business for tax reporting purposes.
- **Phone.** Telephone number to contact business.
- **Fax.** Fax number for business.
- **Email.** Provide email address for electronic correspondence.
- **No Subcontracting/consulting (of any kind) will be performed on this contract.** Checking box indicates your business will not use subcontractors when no Subcontract Goal or Participation Plan Requirement was set by the City, but will self-perform all work. When subcontractors are utilized during the performance of the contract, the “Sub-(Contractors/Consultants/Suppliers) Payments” form (MBD Form-30) must be submitted with every pay application and invoice. Note: certified **SLBE or WMBE firms** bidding as Primes **are not exempt** from outreach and solicitation of subcontractors, including completion and submitting Form-10 and Form-20.
- **No Firms listed To-Be-Utilized.** Check box; provide brief explanation why no firms were retained when a goal or participation plan requirement was set on the contract. Note: mandatory compliance with Good Faith Effort outreach (GFECF) requirements applies (MBD Form-50) and supporting documentation must accompany the bid.
- **See attached documents.** Check box, if after completing the DMI Form in its entirety, you need more space to list additional firms and/or if you have supplemental information/documentation relating to the scope/value/percent utilization of subcontractors. Reproduce copies of MBD-20 and attach. All data not submitted on duplicate forms must be in the same format and content as specified in these instructions.

The following instructions are for information of Any and All subcontractors To Be Utilized.

- **Federal ID. FIN.** A number assigned to a business for tax reporting purposes. This information is critical in proper identification of the subcontractor.
- **“S” = SLBE, “W” = WMBE.** Enter “S” for firms Certified by the City as Small Local Business Enterprises and/or “W” for firms Certified by the City as Women/Minority Business Enterprise; **“O” = Non-certified others.**
- **Company Name, Address, Phone & Fax.** Provide company information for verification of payments.
- **Type of Ownership.** Indicate the Ethnicity and Gender of the owner of the subcontracting business.
- **Trade, Services, or Materials (NIGP code if Known)** Indicate the trade, service, or material provided by the subcontractor. Abbreviated list of NIGP is available at <http://www.tampagov.net/mbd> “Information Resources”.
- **Amount of Quote, Letters of Intent** (required for both SLBEs and WMBEs).
- **Percent of Work/Contract.** Indicate the percent of the total contract price the subcontract(s) represent. For CCNA only (i.e. Consultant A/E Services) you must indicate subcontracts as percent of total scope/contract.
- **Total Subcontract/Supplier Utilization.** – Provide total dollar amount of all subcontractors/suppliers projected to be used for the contract. (Dollar amounts may be optional in CCNA depending on solicitation format).
- **Total SLBE Utilization.** Provide total dollar amount for all projected SLBE subcontractors/Suppliers used for this contract. (Dollar amounts may be optional in CCNA proposals depending on the solicitation format).
- **Total WMBE Utilization.** Provide total dollar amount for all projected WMBE subcontractors/Suppliers used for this contract. (Dollar amounts may be optional in CCNA proposals depending on the solicitation format).
- **Percent SLBE Utilization.** Total amount allocated to SLBEs divided by the total bid/proposal amount.
- **Percent WMBE Utilization.** Total amount allocated to WMBEs divided by the total bid/proposal amount.

If additional information is required or you have questions, please contact the Equal Business Opportunity Program - Minority and Small Business Development Office at (813) 274-5522.

TAMPA BID BOND
Contract 22-C-00034; Citywide Meter, Hydrant and Valve Installation and Replacement

KNOW ALL MEN BY THESE PRESENTS, that we, _____

(hereinafter called the Principal) and _____

(hereinafter called the Surety) a Corporation chartered and existing under the laws of the State of _____, with its principal offices in the City of _____, and authorized to do business in the State of Florida, are held and firmly bound unto the City of Tampa, a Municipal Corporation of Hillsborough County, Florida, in the full and just sum of 5% of the amount of the (Bid) (Proposal) good and lawful money of the United States of America, to be paid upon demand of the City of Tampa, Florida, to which payment will and truly to be made we bind ourselves, our heirs, executors, administrators, successors, and assigns, jointly and severally and firmly these presents.

WHEREAS, the Principal is about to submit, or has submitted to the City of Tampa, Florida, a Proposal for the construction of certain facilities for the City designated Contract 22-C-00034, Citywide Meter, Hydrant and Valve Installation and Replacement.

WHEREAS, the Principal desires to file this Bond in accordance with law, in lieu of a certified Bidder's check otherwise required to accompany this Proposal.

NOW, THEREFORE: The conditions of this obligation are such that if the Proposal be accepted, the Principal shall, within twenty (20) days after the date of receipt of written Notice of Award, execute a contract in accordance with the Proposal and upon the terms, conditions and price set forth therein, in the form and manner required by the City of Tampa, Florida and execute a sufficient and satisfactory Public Construction Bond payable to the City of Tampa, Florida in an amount of one hundred percent (100%) of the total contract price, in form and with security satisfactory to said City, then this Bid Bond obligation is to be void; otherwise to be and remain in full force and virtue in law, and the Surety shall, upon failure of the Principal to comply with any or all of the foregoing requirements within the time specified above, immediately pay to the aforesaid City, upon demand, the amount thereof, in good and lawful money of the United States of America, not as a penalty, but as liquidated damages.

IN TESTIMONY THEREOF, the Principal and Surety have caused these presents to be duly signed and sealed this _____ day of _____, 20____.

Principal

BY _____

TITLE _____

BY _____

TITLE _____

(SEAL)

Producing Agent

Producing Agent's Address

Name of Agency

The addition of such phrases as "not to exceed" or like import shall render the (Bid) (Proposal) non-responsive.

AGREEMENT

For furnishing all labor, materials and equipment, together with all work incidental thereto, necessary and required for the performance of the work for the construction of Contract 22-C-00034 in accordance with your Proposal dated _____, amounting to a total of \$ _____ as completed in accordance with subsections I-2.09 and I-2.10 of the Instruction to Bidders.

This AGREEMENT, made and entered into in triplicate, between the City of Tampa, Florida, hereinafter called the City, and _____ hereinafter called the Contractor, as of the _____ day of _____, 20__ when the City Council of the City of Tampa, Florida adopted a Resolution authorizing, among other things, the Mayor's execution of this Agreement.

WITNESSETH that, in consideration of the mutual stipulations, agreements, and covenants herein contained, the parties hereto have agreed and hereby agree with each other, the Party of the First Part for itself, its successors and assigns, and the Party of the Second Part for itself, or himself, or themselves, and its successors and assigns, or his or their executors, administrators and assigns, as follows:

Contract 22-C-00034; Citywide Meter, Hydrant and Valve Installation and Replacement, shall include, but not be limited to, furnishing and installing water mains and appurtenances ranging in size from 2-inch to 16-inch diameter including concrete masonry, curbs and sidewalks; paving, landscaping, grouting, brick street construction with all associated work required for a complete project in accordance with the Contract Documents.

Contract Documents referred to in Article 1.01 of this Agreement also includes this volume, applicable standard drawings, the plans and any provisions referred to whether actually attached or not.

TAMPA AGREEMENT

SECTION 1 GENERAL

ARTICLE 1.01 THE CONTRACT

Except for titles, subtitles, headings, running headlines, and tables of contents (all of which are printed herein merely for convenience), the following, except for such portions thereof as may be specifically excluded, constitute the Contract:

The Notice to Bidders;
The Instructions to Bidders, including Special Instructions and General Instructions;
The Proposal;
The Bid Bond;
The Certification of Nonsegregated Facilities;
The Notice of Award;
The Agreement;
The Performance Bond;
The Notice To Proceed;
The Specifications, including the General Provisions, the Workmanship and Materials, the Specific Provisions or the Contract Items
The Plans;
All Supplementary Drawings Issued after award of the Contract;
All Addenda issued by the City prior to the receipt of proposals;
All provisions required by law to be inserted in this Contract, whether actually inserted or not.

ARTICLE 1.02 DEFINITIONS

The following words and terms, or pronouns used in their stead, shall, wherever they appear in this Contract, be construed as follows, unless different meaning is clear from the context:

(a)"City" shall mean the City of Tampa, Florida, represented by its Mayor and City Council, Party of the First Part, or such other City official as shall be duly empowered to act for the City on matters relating to this Contract.

(b)"Contractor" shall mean the Party of the Second Part hereto, whether corporation, firm or individual, or any combination thereof, and its, their, or his successors, personal representatives, executors, administrators, and assigns, and any person, firm or corporation who or which shall at any time be substituted in the place of the Party of the Second Part under this Contract.

(c)"Engineer" shall mean the Director of the Department or his duly authorized representative.

(d)"Consultant" shall mean the engineering or architectural firm or individual employed by the City to consult with and advise the City in the construction of the project.

(e)"Surety" shall mean any person, firm or corporation that has executed as Surety the Contractor's Performance Bond securing the performance of this Contract.

(f)"The Work" shall mean everything expressly or implied required to be furnished and done by the Contractor under the Contract, and shall include both Contract Work

and Extra Work.

(g)"Contract Work" shall mean everything expressly or implied required to be furnished and done by the Contractor by any one or more of the Contract parts referred to in Article 1.01 hereof, except Extra Work, as hereinafter defined; it being understood that, in case of any inconsistency in or between any part or parts of this Contract, the Engineer shall determine which shall prevail.

(h)"Contract" or "Contract Documents" shall mean each of the various part of the Contract referred to in Article 1.01 hereof, both as a whole and severally.

(i)"Extra Work" shall mean work other than that required either expressly or implied by the contract in its present form.

(j)"Plans" shall mean only those drawings specifically referred to as such in these documents, or in any Addendum. Drawings issued after the execution of the Contract to explain further, or to illustrate, or to show changes in the work, will be known as "Supplementary Drawings" and shall be binding upon the Contractor with the same force as the Plans.

(k)"Specifications" shall mean all of the directions, requirements, and standards of performance applying to the work, as hereinafter detailed and designated as such, or which may be issued in an addendum.

(l)"Addendum or Addenda" shall mean the additional contract provisions issued in writing prior to the receipt of bids.

(m)"Notice" shall mean written notice. Notice shall be served upon the Contractor, either personally or by leaving the said notice at his residence or with any employee found on the work, or addressed to the Contractor at the residence or place of business given in his proposal and deposited in a postpaid wrapper in any post office box regularly maintained by the United States Post Office.

(n)"Project" shall mean the entire improvement package or related work. The "project" may consist of several different, but related, contracts.

(o)"Site" shall mean, and be limited to, the area upon or in which the Contractor's operations are carried on and such other appropriate areas as may be designed as such by the Engineer.

(p)"Subcontractor" shall mean any person, firm, or corporation, other than employees of the Contractor, who or which contracts with the Contractor to furnish, or actually furnishes labor, or labor and materials, or labor and equipment or labor, materials, and equipment at the site.

(q)Whenever in the Contract the words "directed", "required", "permitted", "ordered", "designated", "prescribed", and words of like import are used, they shall imply the direction, requirement, permission, order, designation, or prescription of the Engineer; and "approved", "acceptable", "satisfactory", "in the judgement of", and words of like import shall mean approved by, or acceptable to, or satisfactory to, or in the judgment of the Engineer.

(r)Whenever in the Contract the word "day" is used, it shall mean calendar day.

(s)"Final Acceptance" shall mean acceptance of the

work as evidenced by an official resolution of the City. Such acceptance shall be deemed to have taken place only if and when an approving resolution has been adopted by the City Council. The final acceptance shall be signed only after the City has assured itself by tests, inspection, or otherwise, that all of the provisions of the Contract have been carried out to its satisfaction.

(t)"Eastern Standard Time" shall be construed as the time being observed in the City on the day proposals are received or other documents issued or signed.

SECTION 2 POWERS OF THE CITY'S REPRESENTATIVES

ARTICLE 2.01 THE ENGINEER

It is covenanted and agreed that the Engineer, in addition to those matters elsewhere herein expressly made subject to his determination, direction, or approval, shall have the power, subject to such express provisions and limitations herein contained as are not in conflict herewith, and subject to review by the Mayor and City Council:

(a)To monitor the performance of the work.

(b)To determine the amount, kind, quality, sequence, and location of the work to be paid for hereunder and, when completed, to measure such work for payment.

(c)To determine all questions of an engineering character in relation to the work, to interpret the Plans, Specifications and Addenda.

(d)To determine how the work of this Contract shall be coordinated with the work of other contractors engaged simultaneously on this project.

(e)To make minor changes in the work as he deems necessary, provided such changes do not result in a net increase in the cost to the City or to the Contractor of the work to be done under the Contract.

(f)To amplify the Plans, add explanatory information and furnish additional Specifications and Drawings consistent with the intent of the Contract Documents.

The power of the Engineer shall not be limited to the foregoing enumeration, for it is the intent of this Contract that all of the work shall be subject to his determinations and approval, except where the determination or approval of someone other than the Engineer is expressly called for herein and except as subject to review by the Mayor and City Council. All orders of the Engineer requiring the Contractor to perform work as Contract work shall be promptly obeyed by the Contractor.

The Engineer shall not, however, have the power to issue an extra work order, and the performance of such work on the order of the Engineer without previously obtaining written confirmation thereof from the Mayor in accordance with Article 7.02 hereof may constitute a waiver of any right to extra compensation therefor. The Contractor is warned that the Engineer has no power to change the terms and provisions of this Contract, except minor changes where such change results in no net increase in the Contract Price.

ARTICLE 2.02 DIRECTOR

The Director of the Department in addition to those matters

expressly made subject to his determination, direction or approval in his capacity as "Engineer", shall also have the power:

(a)To review any and all questions in relation to this Contract and its performance, except as herein otherwise specifically provided, and his determination upon such review shall be final and conclusive upon the Contractor.

(b)With the approval of the Mayor and City Council to authorize modifications or changes in the Contract so as to require: (1) the performance of extra work, or (2) the omission of Contract work whenever he deems it in the interest of the City to do so, or both.

(c)To suspend the whole or any part of the work whenever, in his judgment, such suspension is required: (1) in the interest of the City generally, or (2) to coordinate the work of the various Contractors engaged on this project, or (3) to expedite the completion of the entire project, even though the completion of this particular Contract may be thereby delayed, without compensation to the Contractor for such suspension other than extending the time for the completion of the work, as much as it may have been, in the opinion of the City, delayed by such a suspension.

(d)If, before the final acceptance of all the work contemplated herein, it shall be deemed necessary to take over, use, occupy, or operate any part of the completed or partly completed work, the Engineer shall have the right to do so and the Contractor will not, in any way, interfere with or object to the use, occupation, or operation of such work by the City after receipt of notice in writing from the Engineer that such work or part thereof will be used by the City on and after the date specified in such notice. Such taking over, use, occupancy or operation of any part of the completed or partially completed work shall not constitute final acceptance or approval of any such part of the work.

ARTICLE 2.03 NO ESTOPPEL

The City shall not, nor shall any department, officer, agent, or employee thereof, be bound, precluded, or estopped by any determination, decision, acceptance, return, certificate, or payment made or given under or in connection with this Contract by any officer, agent or employee of the City at any time either before or after final completion and acceptance of the work and payment therefor: (a) from showing the true and correct classification, amount, quality, or character of the work done, or that any determination, decision, acceptance, return certificate or payment is untrue, incorrect or improperly made in any particular, or that the work or any part thereof does not in fact conform to the requirements of the Contract Documents, and (b) from demanding and recovering from the Contractor any overpayments made to him or such damages as it may sustain by reason his failure to comply with the requirements of the Contract of Documents, or both.

ARTICLE 2.04 NO WAIVER OF RIGHTS

Neither the inspection, nor any order, measurements or certificate of the City or its employees, officers, or agents, nor by any order of the City for payment of money, nor any money, nor payments for or acceptance of the whole or any part of the work by the City, nor any extension of time, nor any changes in the Contract, Specifications or Plans, nor any possession by the City or its employees shall operate as a

waiver of any provisions of this Contract, nor any power herein provided nor shall any waiver of any breach of this Contract be held as a waiver of any other subsequent breach.

Any remedy provided in this Contract shall be taken and construed as cumulative, namely, in addition to each and every other suit, action, or legal proceeding. The City shall be entitled as of right to an injunction against any breach of the provisions of this Contract.

SECTION 3 PERFORMANCE OF WORK

ARTICLE 3.01 CONTRACTOR'S RESPONSIBILITY

The Contractor shall do all the work and furnish, at his own cost and expense, all labor, materials, equipment, and other facilities, except as herein otherwise provided, as may be necessary and proper for performing and completing the work under this Contract. The Contractor shall be responsible for the entire work until completed and finally accepted by the City.

The work shall be performed in accordance with the true intent and meaning of the Contract Documents. Unless otherwise expressly provided, the work must be performed in accordance with the best modern practice, with materials as specified and workmanship of the highest quality, all as determined by and entirely to the satisfaction of the Engineer.

Unless otherwise expressly provided, the means and methods of construction shall be such as the Contractor may choose, subject, however, to the approval of the Engineer. Only adequate and safe procedure, methods, structures and equipment shall be used. The Engineer's approval or the Engineer's failure to exercise his right thereon shall not relieve the Contractor of obligations to accomplish the result intended by the Contract, nor shall such create a cause of action for damages.

ARTICLE 3.02 COMPLIANCE WITH LAWS

The Contractor must comply with all local, State and Federal laws, rules, ordinances and regulations applicable to this Contract and to the work done hereunder, and must obtain, at his own expense, all permits, licenses or other authorization necessary for the prosecution of the work.

No work shall be performed under this Contract on Sundays, legal holidays or after regular working hours without the express permission of the Engineer. Where such permission is granted, the Engineer may require that such work be performed without additional expense to the City.

ARTICLE 3.03 INSPECTION

During the progress of the work and up to the date of final acceptance, the Contractor shall, at all times, afford the representatives of the City, the Florida Department of Environmental Regulation, and if applicable, the Federal Environmental Protection Agency and the Federal Department of Labor every reasonable, safe and proper facility for inspecting the work done or being done at the

site. The inspection of any work shall not relieve the Contractor of any of his obligations to perform proper and satisfactory work as herein specified. Finished or unfinished work found not to be in strict accordance with the Contract shall be replaced as directed by the Engineer, even though such work may have been previously approved and payment made therefor.

The City shall have the right to reject materials and workmanship which are defective or require their correction. Rejected work and materials must be promptly removed from the site, which must at all times be kept in a reasonably clean and neat condition.

Failure or neglect on the part of the City to condemn or reject bad or inferior work or materials shall not be construed to imply an acceptance of such work or materials, if it becomes evident at any time prior to the final acceptance of the work by the City. Neither shall it be construed as barring the City at any subsequent time from the recovery of damages of such a sum of money as may be needed to build anew all portions of the work in which inferior work or improper materials were used, wherever found.

Should it be considered necessary or advisable by the City at any time before final acceptance of the entire work to make examinations of work already completed, by removing or tearing out all or portions of such work, the Contractor shall, on request, promptly furnish all necessary facilities, labor, and material for that purpose. If such work is found to be defective in any material respect, due to the fault of the Contractor or his subcontractors, he shall defray all expenses of such examination and of satisfactory reconstruction. If, however, such work is found to meet the requirements of the Contract, the cost of examination and restoration of the work shall be considered an item of extra work to be paid for in accordance with the provisions of Article 7.02 hereof.

ARTICLE 3.04 PROTECTION

During performance and until final acceptance, the Contractor shall be under an absolute obligation to protect the finished and unfinished work against any damage, loss, or injury. The Contractor shall take proper precaution to protect the finished work from loss or damage, pending completion and the final acceptance of all the work included in the entire Contract, provided that such precaution shall not relieve the Contractor from any and all liability and responsibility for loss or damage to the work occurring before final acceptance by the City. Such loss or damage shall be at the risk of and borne by the Contractor, whether arising from acts or omissions of the Contractor or others. In the event of any such loss or damage, the Contractor shall forthwith repair, replace, and make good the work without extension of time therefor, except as may be otherwise provided herein.

The provisions of this Article shall not be deemed to create any new right of action in favor of third parties against the Contractor or the City.

ARTICLE 3.05 PRESERVATION OF PROPERTY

The Contractor shall preserve from damage all property along the line of the work, or which is in the vicinity of or is in anywise affected by the work, the removal or destruction of which is not called for by the Plans. This applies, but is not limited, to the public utilities, trees, lawn areas, building monuments, fences, pipe and underground structures, public streets (except natural wear and tear of streets resulting from legitimate use thereof by the Contractor), and wherever such property is damaged due to the activities of the Contractor, it shall be immediately restored to its original condition by the Contractor and at his own expense.

In case of failure on the part of the Contractor to restore such property, or make good such damage or injury, the City may, upon forty-eight (48) hour written notice, proceed to repair, rebuild, or otherwise restore such property as may be deemed necessary, and the cost thereof will be deducted from any monies due or which may become due the Contractor under this Contract. Nothing in this clause shall prevent the Contractor from receiving proper compensation for the removal, damage, or replacement of any public or private property not shown on the Plans, when this is made necessary by alteration of grade or alignment authorized by the Engineer, provided that such property has not been damaged through fault of the Contractor, his employees or agents.

ARTICLE 3.06 BOUNDARIES

The Contractor shall confine his equipment, apparatus, the storage of materials, supplies and apparatus of his workmen to the limits indicated on the plans, by law, ordinances, permits or direction of the Engineer.

ARTICLE 3.07 SAFETY AND HEALTH REGULATIONS

The Contractor shall comply with the Department of Labor Safety and Health Regulations for construction promulgated under the Occupational Safety and Health Act of 1970 (PL 91- 596) and under Section 107 of the Contract Work Hours and Safety Standards Act (PL91-54).

ARTICLE 3.08 TAXES

All taxes of any kind and character payable on account of the work done and materials furnished under this Contract shall be paid by the Contractor and shall be deemed to have been included in his bid. The laws of the State of Florida provide that sales and use taxes are payable by the Contractor upon the tangible personal property incorporated in the work and such taxes shall be paid by the Contractor and shall be deemed to have been included in his bid.

ARTICLE 3.09 ENVIRONMENTAL CONSIDERATIONS

The Contractor, in the performance of the work under this Contract, shall comply with all Local, State and Federal laws, statutes, ordinances, rules and regulations applicable to protection of the environment; and, in the event he violates any of the provisions of same, he shall be answerable to the Local, State and Federal agencies designated by law to protect the environment. In the event the City receives, from any of the environmental agencies, a citation which is occasioned by an act or omission of the Contractor or his

subcontractor or any officers, employees or agents of either, it is understood and agreed that the Contractor shall automatically become a party-respondent under said citation; and the City immediately shall notify the Contractor and provide him with a copy of said citation.

The Contractor shall comply with the requirements of the citation and correct the offending condition(s) within the time stated in said citation and further shall be held fully responsible for all fines and/or penalties.

**SECTION 4
TIME PROVISIONS**

ARTICLE 4.01 TIME OF START AND COMPLETION

The Contractor must commence work within thirty (30) days subsequent to the date of the receipt of the "Notice to Proceed" by the City unless otherwise provided in the Specific Provisions and Special Instructions. Time being of the essence of this Contract, the Contractor shall thereafter prosecute the work diligently, using such means and methods of construction as well as secure its full completion in accordance with the requirements of the Contract Documents no later than the date specified therefor, or on the date to which the time for completion may be extended.

The Contractor must complete the work covered by this Contract in the number of consecutive calendar days set forth in the Instructions to Bidders, unless the date of completion is extended pursuant to the provisions of Article 4.05 hereof.

The period for performance shall start from the date of signing of this Agreement by the City.

The actual date of completion will be established after a final inspection as provided in Article 4.07 hereof.

ARTICLE 4.02 PROGRESS SCHEDULE

To enable the work to be laid out and prosecuted in an orderly and expeditious manner, the Contractor shall submit to the Engineer a proposed progress schedule within fifteen (15) days after the award of this Contract.

The schedule shall state the Contract starting date, time for completion and date of completion and shall show the anticipated time of starting and completion of each of the various operations to be performed under this Contract, together with all necessary and appropriate information regarding sequence and correlation of work and an estimated time required for the delivery of all materials and equipment required for the work. The proposed schedule shall be revised as directed by the Engineer until finally approved by him, and, after such approval, shall be strictly adhered to by the Contractor. The approved progress schedule may be changed only with the written permission of the Engineer.

If the Contractor shall fail to adhere to the approved progress schedule or the schedule as revised, he shall promptly adopt such other or additional means and methods of construction as will make up for the time lost, and will assure completion in accordance with the contract time.

ARTICLE 4.03 APPROVAL REQUESTS

From time to time, as the work progresses and in the sequence indicated by the approved schedule, the Contractor must submit to the Engineer a specific request, in writing, for each item of information or approval required of him by the Contract. These requests must be submitted sufficiently in advance of the date upon which the information or approval is actually required by the Contractor to allow for the time the Engineer may take to act upon such submissions or resubmissions. The Contractor shall not have any right to an extension of time on account of delays due to his failure to submit his requests for the required information or the required approval in accordance with these requirements.

ARTICLE 4.04 COORDINATION WITH OTHER CONTRACTORS

During progress of the work, other Contractors may be engaged in performing other work on this project or on other projects on the site. In that event, the Contractor shall coordinate the work to be done hereunder with the work of such other Contractors in such manner as the Engineer may direct.

ARTICLE 4.05 EXTENSION OF TIME

If such an application is made, the Contractor shall be entitled to an extension of time for delay in completion of the work should the Contractor be obstructed or delayed in the commencement, prosecution or completion of any part of said work by any act or delay of the City, or by acts or omissions of other Contractors on this project, or by a riot, insurrection, war, pestilence, acts of public authorities, fire, lightning, hurricanes, earthquakes, tornadoes, floods, extremely abnormal and excessive inclement weather as indicated by the records of the local weather bureau for a five-year period preceding the date of the Contract, or by strikes, or other causes, which causes of delay mentioned in this Article, in the opinion of the City, are entirely beyond the expectation and control of the Contractor.

The Contractor shall, however, be entitled to an extension of time for such causes only for the number of days of delay which the City may determine to be due solely to such causes and only to the extent that such occurrences actually delay the completion of the project and then only if the Contractor shall have strictly complied with all of the requirements of Articles 4.01, 4.02, 4.03 and 4.04 hereof. It is hereby understood that the determination by the Engineer as to the order and sequence of the work shall not in itself constitute a basis for extension of time.

The determination made by the City on an application for an extension of time shall be binding and conclusive on the Contractor.

Delays caused by failure of the Contractor's materialmen, manufacturers, and dealers to furnish approved working drawings, materials, fixtures, equipment, appliances, or other fittings on time or failure of subcontractors to perform their work shall not constitute a basis of extension of time.

The Contractor agrees to make no claim for damages for delay in the performance of this Contract occasioned by any

act or omission to act of the City or any of its representatives or because of any injunction which may be brought against the City or its representatives and agrees that any such claim shall be fully compensated for by an extension of time to complete performance of the work as provided herein.

ARTICLE 4.06 LIQUIDATED DAMAGES

It is mutually agreed between the parties that time is the essence of this Contract and that there will be on the part of the City considerable monetary damage in the event the Contractor should fail to complete the work within the time fixed for completion in the Contract or within the time to which such completion may have been extended.

The amount per day set forth in the Instructions to Bidders is hereby agreed upon as the liquidated damages for each and every calendar day that the time consumed in completing the work under this Contract exceeds the time allowed.

This amount shall, in no event, be considered as a penalty or otherwise than as the liquidated and adjusted damages to the City because of the delay and the Contractor and his Surety agree that the stated sum per day for each such day of delay shall be deducted and retained out of the monies which may become due hereunder and if not so deductible, the Contractor and his Surety shall be liable therefor.

ARTICLE 4.07 FINAL INSPECTION

When the work has been completed in accordance with the requirements of the Contract and final cleaning up performed, a date for final inspection of the work by the Engineer shall be set by the Contractor in a written request therefor, which date shall be not less than ten (10) days after the date of such request. The work will be deemed complete as of the date so set by the Contractor if, upon such inspection, the Engineer determines that no further work remains to be done at the site.

If such inspection reveals interms of work still to be performed, however, the Contractor shall promptly perform them and then request a reinspection. If, upon such inspection, the Engineer determines that the work is complete, the date of final completion shall be deemed to be the last day of such reinspection.

**SECTION 5
SUBCONTRACTS AND ASSIGNMENTS**

ARTICLE 5.01 LIMITATIONS AND CONSENT

The Contractor shall not assign, transfer, convey, sublet or otherwise dispose of this Contract or of his right, title, or interest therein, or his power to execute such Contract, or to assign any monies due or to become due thereunder to any other person, firm or corporation unless the previous written consent of the City shall first be obtained thereto and the giving of any such consent to a particular subcontract or assignment shall not dispense with the necessity of such consent to any further or other assignment.

Before making any subcontract, the Contractor must submit a

written statement to the Engineer, giving the name and address of the proposed contractor, the portion of the work and materials which he is to perform and furnish and any other information tending to prove that the proposed subcontractor has the necessary facilities, skill, integrity, past experience and financial resources to perform the work in accordance with the terms and conditions of this Contract.

If the City finds that the proposed subcontractor is qualified, the Contractor will be notified in writing. The City may revoke approval of any subcontractor when such subcontractor evidences an unwillingness or inability to perform his work in strict accordance with these Contract Documents. Notice of such revocation of approval will be given in writing to the Contractor.

The Contractor will promptly, upon request, file with the City a conformed copy of the subcontract. The Contractor shall cause appropriate provisions to be inserted in all subcontracts relative to the work to bind subcontractors to the Contractor by the terms of these Contract Documents, insofar as applicable to the work of subcontractors, and to give the Contractor the same power as regards terminating any subcontracts that the City may exercise over the Contractor under provisions of these Contract Documents.

The Contractor shall be required to perform with his own forces at least twenty-five (25) percent of the work, unless written consent to subcontract a greater percentage of the work is first obtained from the City.

ARTICLE 5.02 RESPONSIBILITY

The approval by the City of a subcontractor shall not relieve the Contractor of any of his responsibilities, duties, and liabilities hereunder. The Contractor shall be solely responsible to the City for the acts or defaults or omissions of his subcontractor and of such subcontractor's officers, agents, and employees, each of whom shall for all purposes be deemed to be the agent or employee of the Contractor. Nothing contained in the Contract Documents shall create any contractual relationship between any subcontractor and the City.

SECTION 6 SECURITY AND GUARANTY

ARTICLE 6.01 CONTRACT SECURITY

The Contractor shall execute and deliver to the City a Performance Bond on the form as provided herein, in an amount at least equal to one hundred (100) percent of the full Contract price, such Bond to be executed by a surety company acceptable to the City. The surety on such Performance Bond shall be a surety company duly authorized to do business in the State of Florida, and the Bond shall be issued or countersigned by a local resident producing agent of such surety company who is a resident of the State of Florida, regularly commissioned and licensed in said State, and satisfactory evidence of the authority of the person or persons executing such Bond shall be submitted with the Bond. The Performance Bond shall serve as security for the faithful performance of this Contract, including

maintenance and guaranty provisions, and for the payment of all persons performing labor and furnishing materials in connection with the Contract. The premiums on the Performance Bond shall be paid by the Contractor.

If, at any time, the City shall become dissatisfied with any surety or sureties then upon the Performance Bond, or if for any other reason such bond shall cease to be adequate security for the City, the Contractor shall, within five days after notice so to do, substitute an acceptable Bond in such form and sum and signed by such other sureties as may be satisfactory to the City. The premiums on such Bond shall be paid by the Contractor. No further partial payments shall be deemed due or shall be made until the new sureties have qualified.

ARTICLE 6.02 CONTRACTORS INSURANCE

Insurance required shall be as indicated on Special Instructions pages beginning with "INS-1"

ARTICLE 6.03 AGAINST CLAIMS AND LIENS

The City may withhold from the Contractor as much as any approved payments to him as may, in the opinion of the City, be necessary to secure (a) just claims of any persons supplying labor or materials to the Contractor or any of his subcontractors for the work then due and unpaid; (b) loss due to defective work not remedied, or (c) liability, damage, or loss due to injury to persons or damages to the work or property of other contractors, subcontractors, or others, caused by the act or neglect of the Contractor or of any of his subcontractors. The City shall have the right, as agent for the Contractor, to apply any such amounts so withheld in such manner as the City may deem proper to satisfy such claims or to secure such protection. Such application of such money shall be deemed payments for the account of the Contractor.

ARTICLE 6.04 MAINTENANCE AND GUARANTY

The Contractor hereby guarantees all the work furnished under this Contract against any defects in workmanship and materials for a period of one year following the date of final acceptance of the work by the City. Under this guarantee, the Contractor hereby agrees to make good, without delay, at his own expense, any failure of any part of the work due to faulty materials or manufacture, construction, or installation, or the failure of any equipment to perform satisfactorily all the work put upon it within the limits of the Contract Documents, and further, shall make good any damage to any part of the work caused by such failure. It is hereby agreed that the Performance Bond shall fully cover all guarantees contained in this Article.

It is also agreed that all warranties, expressed or implied, inure to the benefit of the City and are enforceable by the City.

SECTION 7 CHANGES

ARTICLE 7.01 MINOR CHANGES

The City reserves the right to make such additions, deductions, or changes to this Contract from time to time as

it deems necessary and in a manner not materially affecting the substance thereof or materially changing the price to be paid in order to carry out and complete more fully and perfectly the work herein agreed to be done and performed. This Contract shall in no way be invalidated by any such additions, deductions, or changes, and no claim by the Contractor shall be made for any loss of anticipated profits thereby.

Construction conditions may require that minor changes be made in the location and installation of the work and equipment to be furnished and other work to be performed hereunder, and the Contractor when ordered by the Engineer, shall make such adjustments and changes in said locations and work as may be necessary, without additional cost to the City, provided such adjustments and changes do not alter the character, quantity or cost of the work as a whole, and provided further that Plans and Specifications showing such adjustments and changes are furnished to the Contractor by the City within a reasonable time before any work involving such adjustment and changes is begun. The Engineer shall be the sole judge of what constitutes a minor change for which no additional compensation shall be allowed.

ARTICLE 7.02 EXTRA WORK

The City may at any time by a written order and without notice to the sureties require the performance of such extra work as it may find necessary or desirable. An order for extra work shall be valid only if issued in writing and signed by the Mayor and the work so ordered must be performed by the Contractor.

The amount of compensation to be paid to the Contractor for any extra work as so ordered shall be determined as follows:

(a) By such applicable unit prices, if any, as are set forth in the Proposal; or

(b) If no such unit prices are set forth then by a lump sum or other unit prices mutually agreed upon by the City and the Contractor; or

(c) If no such unit prices are set forth in the Proposal and if the parties cannot agree upon a lump sum or other unit prices then by the actual net cost in money to the Contractor of the extra work performed, which cost shall be determined as follows:

(1) For all labor and foreman in direct charge of the authorized operations, the Contractor shall receive the current local rate of wages to be agreed upon, in writing, before starting such work for each hour that said labor and foremen are actually engaged thereon, to which shall be added an amount equal to 25 percent of the sum thereof which shall be considered and accepted as full compensation for general supervision, FICA taxes, contributions under the Florida Unemployment Compensation Act, insurance, bond, subcontractor's profit and overhead, the furnishing of small tools and miscellaneous equipment used, such as picks, shovels, hand pumps, and similar items.

(2) For all materials used, the Contractor shall receive the actual cost of such materials delivered at the site or previously approved delivery point as established by original receipted bills. No percentage shall be added to this cost.

(3) For special equipment and machinery such as power-driven pumps, concrete mixers, trucks, and tractors, or other equipment, required for the economical performance of the authorized work, the Contractor shall receive payment based on the average local area rental price for each item of equipment and the actual time of its use on the work. No percentage shall be added to this sum.

(4) Records of extra work done under this procedure shall be reviewed at the end of each day by the Contractor or his representative and the Engineer. Duplicate copies of accepted records shall be made and signed by both Contractor or his representative and the Engineer, and one copy retained by each.

Request for payment for approved and duly authorized extra work shall be submitted in the same form as Contract work or in the case of work performed under paragraph (c) (1) above upon a certified statement supported by receipted bills. Such statement shall be submitted for the current Contract payment for the month in which the work was done.

ARTICLE 7.03 DISPUTED WORK

If the Contractor is of the opinion that any work required, necessitated, or ordered violates the terms and provisions of this Contract, he must promptly notify the Engineer, in writing, of his contentions with respect thereto and request a final determination thereof. If the Engineer determines that the work in question is Contract work and not extra work or that the order complained of is proper, he will direct the Contractor to proceed and the Contractor shall promptly comply. In order, however, to reserve his right to claim compensation for such work or damages resulting from such compliance, the Contractor must, within five (5) days after receiving notice of the Engineer's determination and direction, notify the City in writing that the work is being performed or that the determination and direction is being complied with under protest. Failure of the Contractor to notify shall be deemed as a waiver of claim for extra compensation or damages therefor.

Before final acceptance by the City, all matters of dispute must be adjusted to the mutual satisfaction of the parties thereto. Final determinations and decisions, in case any questions shall arise, shall constitute a condition precedent to the right of the Contractor to receive the money therefor until the matter in question has been adjusted.

ARTICLE 7.04 OMITTED WORK

The City may at any time by a written order and without notice to the sureties require the omission of such Contract work as it may find necessary or desirable.

An order for omission of work shall be valid only if signed by the Mayor and the work so ordered must be omitted by the Contractor. The amount by which the Contract price shall be reduced shall be determined as follows:

(a) By such applicable unit prices, if any, as are set forth in the Contract; or

(b) By the appropriate lump sum price set forth in the Contract; or

(c) By the fair and reasonable estimated cost to the City

of such omitted work as determined by the Engineer and approved by the City.

SECTION 8 CONTRACTOR'S EMPLOYEES

ARTICLE 8.01 CHARACTER AND COMPETENCY

The Contractor and his subcontractors shall employ upon all parts of the work herein contracted for only competent, skillful, and trustworthy workers. Should the Engineer at any time give notice, in writing, to the Contractor or his duly authorized representative on the work that any employee in his opinion is incompetent, unfaithful, disorderly, careless, unobservant of instructions, or in any way a detriment to the satisfactory progress of the work, such employee shall immediately be dismissed and not again allowed upon the site.

ARTICLE 8.02 SUPERINTENDENCE

The Contractor shall give his personal supervision to the faithful prosecution of the work and in case of his absence shall have a competent, experienced, and reliable supervisor or superintendent, acceptable to the Engineer on the site who shall follow without delay all instructions of the Engineer in the prosecution and completion of the work and every part thereof, in full authority to supply workers, material, and equipment immediately. He shall keep on hand at all times copies of the Contract Documents.

ARTICLE 8.03 EMPLOYMENT OPPORTUNITIES

The Contractor shall, in the performance of the work required to be done under this Contract, employ all workers without discrimination regarding race, creed, color, sex or national origin and must not maintain or provide facilities that are segregated on the basis of race, color, creed or national origin.

ARTICLE 8.04 RATES OF WAGES

On federally assisted projects, the rates of wages to be paid under this Contract shall not be less than the rates of wages set forth in Section 12 of this Agreement.

On other projects, no wage rate determination is included. Florida's Prevailing Wage Law (Section 215.19, Florida Statutes) was repealed effective April 25, 1979.

ARTICLE 8.05 PAYROLL REPORTS

The Contractor and each subcontractor shall, if requested to do so, furnish to the Engineer a duly certified copy of his payroll and also any other information required by the Engineer to satisfy him that the provisions of the law as to the hours of employment and rate of wages are being observed.

Payrolls shall be prepared in accordance with instructions furnished by the City and on approved forms. The Contractor shall not carry on his payroll any persons not employed by him. Subcontractor's employees shall be carried only on the payrolls of the employing subcontractor.

SECTION 9 CONTRACTOR'S DEFAULT

ARTICLE 9.01 CITY'S RIGHT AND NOTICE

It is mutually agreed that: (a) if the Contractor fails to begin work when required to do so, or (b) if at any time during the progress of the work it shall appear to the Engineer that the Contractor is not prosecuting the work with reasonable speed, or is delaying the work unreasonably and unnecessarily, or (c) if the force of workmen or quality or quantity of material furnished are not sufficient to insure completion of the work within the specified time and in accordance with the Specifications hereto attached, or (d) if the Contractor shall fail to make prompt payments for materials or labor or to subcontractors for work performed under the Contract, or (e) if legal proceedings have been instituted by others than the City in such manner as to interfere with the progress of the work and may subject the City to peril of litigation or outside claims of (f) if the Contractor shall be adjudged a bankrupt or make an assignment for the benefit of creditors, or (g) if in any proceeding instituted by or against the Contractor an order shall be made or entered granting an extension of time of payment, composition, adjustment, modification, settlement or satisfaction of his debts or liabilities, or (h) if a receiver or trustee shall be appointed for the Contractor or the Contractor's property, or (i) if the Contract or any part thereof shall be sublet without the consent of the City being first obtained in writing, or (j) if this Contract or any right, monies, or claim thereunder shall be assigned by the Contractor, otherwise than as herein specified, or (k) if the Contractor shall fail in any manner of substance to observe the provisions of this Contract, or (l) if any of the work, machinery, or equipment shall be defective, and shall not be replaced as herein provided, or (m) if the work to be done under this Contract shall be abandoned, then such fact or conditions shall be certified by the Engineer and thereupon the City without prejudice to any other rights or remedies of the City, shall have the right to declare the Contractor in default and so notify the Contractor by a written notice, setting forth the ground or grounds upon which such default is declared and the Contractor must discontinue the work, either as a portion of the work or the whole thereof, as directed.

ARTICLE 9.02 CONTRACTOR'S DUTY UPON DEFAULT

Upon receipt of notice that his Contract is in default, the Contractor shall immediately discontinue all further operations on the work or such part thereof, and shall immediately quit the site or such part thereof, leaving untouched all plant, materials, equipment, tools, and supplies.

ARTICLE 9.03 COMPLETION OF DEFAULTED WORK

The City, after declaring the Contractor in default, may then have the work completed or the defective equipment or machinery replaced or anything else done to complete the work in strict accordance with the Contract Documents by such means and in such manner, by Contract with or without public letting, or otherwise, as it may deem advisable,

utilizing for such purpose without additional cost to the City such of the Contractor's plant, materials, equipment, tools, and supplies remaining on the site, and also such subcontractors as it may deem advisable.

The City shall reimburse all parties, including itself, for the expense of such completion, including liquidated damages, if any, and the cost of reletting. The City shall deduct this expense from monies due or to become due to the Contractor under this Contract, or any part thereof, and in case such expense is more than the sum remaining unpaid of the original contract price, the Contractor and his sureties shall pay the amount of such deficiency to the City.

ARTICLE 9.04 PARTIAL DEFAULT

In case the City shall declare the Contractor in default as to a part of the work only, the Contractor shall discontinue such part, shall continue performing the remainder of the work in strict conformity with the terms of the Contract, and shall in no way hinder or interfere with any other contractor or person whom the City may engage to complete the work as to which the Contractor was declared in default.

SECTION 10 PAYMENTS

ARTICLE 10.01 PRICES

For the Contractor's complete performance of the work, the City will pay and the Contractor agrees to accept, subject to the terms and conditions hereof, the lump sum prices or unit prices in the Contractor's Proposal and the award made therein, plus the amount required to be paid for any extra work ordered under Article 7.02 hereof, less credit for any work omitted pursuant to Article 7.04 hereof. Under unit price items, the number of units actually required to complete the work under the Contract may be more than stated in the Proposal. The Contractor agrees that no claim will be made for any damages or for loss of profits because of a difference between the quantities of the various classes of work assumed and stated in the Proposal Form as a basis for comparing Proposals and the quantities of work actually performed.

The sum as awarded for any lump sum Contract or lump sum Contract Item shall represent payment in full for all of the various classes of work, including materials, equipment, and labor necessary or required to complete, in conformity with the Contract Document, the entire work shown, indicated or specified under the lump sum Contract or lump sum Contract Item.

The amount as awarded as a unit price for any unit price Contract Item shall represent payment in full for all the materials, equipment, and labor necessary to complete, in conformity with the Contract Documents, each unit of work shown, specified, or required under the said unit price Contract Item.

No payment other than the amount as awarded will be made for any class of work included in a lump sum Contract Item or a unit price Contract Item, unless specific provision is

made therefor in the Contract Documents.

ARTICLE 10.02 SUBMISSION OF BID BREAKDOWN

Within fifteen (15) days after the execution of this Contract, the Contractor must submit to the Engineer in duplicate an acceptable breakdown of the lump sums and unit prices bid for items of the Contract, showing the various operations to be performed under the Contract, as described in the progress schedule required under Article 4.02 hereof, and the value of each of such operations, the total of such items to equal the total price bid. The Contractor shall also submit such other information relating to the bid prices as may be required and shall revise the bid breakdown as directed. Thereafter, the breakdown may be used for checking the Contractor's applications for partial payments hereunder but shall not be binding upon the City or the Engineer for any purpose whatsoever.

ARTICLE 10.03 REPORTS, RECORDS AND DATA

The Contractor shall furnish to the Engineer such schedules of quantities and costs, progress schedules, reports, invoices, delivery tickets, estimates, records, and other data as the Engineer may request concerning work performed or to be performed and the materials furnished under the Contract.

ARTICLE 10.04 PAYMENTS BY CONTRACTOR

The Contractor shall pay (a) for all transportation and utility services not later than the 20th day of the calendar month following that in which such services are rendered, (b) for all materials, tools, and equipment delivered at the site of the project, and the balance of the cost thereof not later than the 30th day following the completion of that part of the work in or on which such materials, tools, and equipment are incorporated or used, and (c) to each of his subcontractors, not later than the 5th day following each payment to the Contractor, the respective amounts allowed the Contractor on account of the work performed by his subcontractors, to the extent of each subcontractor's interest therein; and proof of such payments or releases therefor shall be submitted to the Engineer upon request.

ARTICLE 10.05 PARTIAL PAYMENTS

On or about the first of each month, the Contractor shall make and certify an estimate, on forms prescribed by the City, of the amount and fair value of the work done, and may apply for partial payment therefor. The Contractor shall revise the estimate as the Engineer may direct. When satisfactory progress has been made, and shows that the value of the work completed since the last payment exceeds one percent (1%) of the total Contract price in amount, the Engineer will issue a certificate that such work has been completed and the value thereof. The City will then issue a voucher to the Contractor in accordance with the following schedule:

FOR CONTRACT AMOUNTS UNDER \$250,000

(A) In the amount of ninety percent (90%) of the value of the work completed as certified until construction is one hundred percent (100%) complete (operational or beneficial occupancy), the withheld amount may be reduced below ten percent (10%), at the Engineer's option, to only that amount necessary to assure completion.

FOR CONTRACT AMOUNTS OVER \$250,000

(A) In the amount of ninety percent (90%) of the value of the work completed as certified until construction is fifty percent (50%) complete.

(B) When the dollar value, as determined by the Engineer, of satisfactorily completed work in place is greater than fifty percent (50%) of the original contract price, vouchers for partial payment will be issued by the City to the Contractor in the amount of one hundred percent (100%) of the value of the work, above 50%, completed as certified for that payment period.

(C) If the Contractor has performed satisfactorily and the work is substantially complete (operational or beneficial occupancy) the withheld amount may be reduced, at the Engineer's option, to only that amount necessary to assure completion.

In addition to the Conditions set forth in (A), (B), and (C) above, payments will always be less any sums that may be retained or deducted by the City under the terms of any of the contract documents and less any sums that may be retained to cover monetary guarantees for equipment, materials or progress performance.

Payment on estimates made on or about the first of the month may be expected on or about the 20th of the month.

Unless specified otherwise in the Contract Items, the delivered cost of equipment and nonperishable materials suitably stored at the site of the work and tested for adequacy may be included in the Contractor's application for partial payment provided, however, that the Contractor shall furnish evidence satisfactory to the City that the Contractor is the unconditional owner and in possession of such materials or equipment. The amount to be paid will be 90 percent of the invoice cost to the Contractor which cost shall be supported by receipted bills within 30 days of the date of payment by the City to the Contractor. Such payment shall not relieve the Contractor from full responsibility for completion of the work and for protection of such materials and equipment until incorporated in the work in a permanent manner as required by the Contract Documents.

Before any payment will be made under this Contract, the Contractor and every subcontractor, if required, shall deliver to the Engineer a written, verified statement, in satisfactory form, showing in detail all amounts then due and unpaid by such Contractor or subcontractor to all laborers, workmen, and mechanics, employed by him under the Contract for the performance of the work at the site thereof, for daily or weekly wages, or to other persons for materials, equipment, or supplies delivered at the site of the work during the period covered by the payment under consideration.

ARTICLE 10.06 FINAL PAYMENT

Under determination of satisfactory completion of the work under this Contract as provided in Article 4.07 hereof, the Engineer will prepare the final estimate showing the value of the completed work. This estimate will be prepared within 30 days after the date of completion or as soon thereafter as the necessary measurements and computations can be made.

All prior certificates and estimates, being approximate only, are subject to correction in the final estimate and payment.

When the final estimate has been prepared and certified by Engineer, he will submit to the Mayor and City Council the final certificate stating that the work has been completed and the amount based on the final estimate remaining due to the Contractor. The City will then accept the work as fully completed and will, not later than 30 days after the final acceptance, as defined in Article 1.02, of the work done under this Contract, pay the Contractor the entire amount so found due thereunder after deduction of all previous payments and all percentages and amounts to be kept and retained under provisions of this Contract; provided, however, and it is understood and agreed that, as a precedent to receiving final payment, the Contractor shall submit to the City a sworn affidavit that all bills for labor, service, materials, and subcontractors have been paid and that there are no suits pending in connection with this work. The City, at its option, may permit the Contractor to execute a separate surety bond in a form satisfactory to the City. The surety bond shall be in the full amount of the suit or suits.

Neither the final payment nor any part of the retained percentage shall be paid until the Contractor, if required, shall furnish the City with a complete release from any should remain unsatisfied after all payments are made, the Contractor shall refund to the City all monies which the City may be compelled to pay in discharging such claim, including incidental costs and attorney's fees.

ARTICLE 10.07 ACCEPTANCE OF FINAL PAYMENT

The acceptance by the Contractor, or by anyone claiming by or through him, of the final payment shall operate as and shall be a release to the City and every officer and agent thereof from any and all claims and liability to the Contractor for anything done or furnished in connection with the work or project and for any act or neglect of the Contractor or of any others relating to or affecting the work. No payment, however, final or otherwise, shall operate to release the Contractor or his sureties from any obligations under this Contract or the Performance Bond.

SECTION 11 MISCELLANEOUS PROVISIONS

ARTICLE 11.01 CONTRACTOR'S WARRANTIES

In consideration of, and to induce the award of this contract to him, the Contractor represents and warrants:

- (a) That he is not in arrears to the City upon debt or contract, and he is not a defaulter, as surety, contractor, or otherwise.
- (b) That he is financially solvent and sufficiently experienced and competent to perform the work.
- (c) That the work can be performed as called for by the Contract Documents.
- (d) That the facts stated in his proposal and the information given by him are true and correct in all respects.
- (e) That he is fully informed regarding all the conditions affecting the work to be done and labor and materials to be

furnished for the completion of this Contract, and that his information was secured by personal investigation and research.

ARTICLE 11.02 PATENTED DEVICES, MATERIAL AND PROCESSES

It is mutually understood and agreed that Contract prices include all royalties and costs arising from patents, trademarks, and copyrights in any way involved in the work. Whenever the Contractor is required or desires to use any design, device, material, or process covered by letters of patent or copyright, the Contractor shall indemnify and save harmless the City, its officers, agents and employees from any and all claims for infringement by reason of the use of any such patented design, device, tool, material, equipment, or process, to be performed under the Contract, and shall indemnify the said City, its officers, agents, and employees for any costs, expenses, and damages which may be incurred by reason of such infringement at any time during the prosecution or after completion of the work.

ARTICLE 11.03 SUITS AT LAW

In case any action at law or suit in equity may or shall be brought against the City or any of its officers, agents, or employees for or on account of the failure, omission, or neglect of the Contractor or his subcontractors, employees, or agents, to do or perform any of the covenants, acts, matters, or things by this Contract undertaken to be done or performed by the Contractor or his subcontractors, employees, or agents, or from any injuries done to property or persons and caused by the negligence or alleged negligence of the Contractor or his subcontractors, employees, or agents, or in any other manner arising out of the performance of this Contract, then the Contractor shall immediately assume and take charge of the defense of such actions or suits in like manner and to all intents and purposes as if said actions or suits have been brought directly against the Contractor, and the Contractor shall also indemnify and save harmless the City, its officers, agents, and employees from any and all loss, cost or damage whatever arising out of such actions or suits, in like manner and to all intents and purposes as if said actions or suits have been brought directly against the Contractor.

The Contractor shall and does hereby assume all liability for and agrees to indemnify the City or its Engineer against any or all loss, costs, damages, and liability for any or by reason of any lien, claims or demands, either for materials purchased or for work performed by laborers, mechanics, and others and from any damages, costs, actions, or causes of action and judgement arising from injuries sustained by mechanics, laborers, or other persons by reason of accidents or otherwise, whether caused by the carelessness or inefficiency or neglect of said Contractor, his subcontractors, agents, employees, workmen or otherwise.

ARTICLE 11.04 CLAIMS FOR DAMAGES

If the Contractor shall claim compensation for any damage sustained, other than for extra or disputed work covered by Article 7.02 and 7.03 hereof, by reason of any act or omission of the City, its agents, or any persons, he shall, within five days after sustaining such damage, make and

deliver to the Engineer a written statement of the nature of the damage sustained and of the basis of the claim against the City. On or before the 15th of the month succeeding that in which any damage shall have been sustained, the Contractor shall make and deliver to the Engineer an itemized statement of the details and amounts of such damage, duly verified by the Contractor. Unless such statements shall be made delivered within the times aforesaid, it is stipulated that and all claims for such compensation shall be forfeited and invalidated, and the Contractor shall not be entitled to payment on account of such claims.

ARTICLE 11.05 NO CLAIMS AGAINST INDIVIDUALS

No claim whatsoever shall be made by the Contractor against any officer, agent, employee of the City for, or on account of, anything done or omitted to be done in connection with this Contract.

ARTICLE 11.06 LIABILITY UNAFFECTED

Nothing herein contained shall in any manner create any liability against the City on behalf of any claim for labor, services, or materials, or of subcontractors, and nothing herein contained shall affect the liability of the Contractor or his sureties to the City or to any workmen or materialsmen upon bond given in connection with this Contract.

ARTICLE 11.07 INDEMNIFICATION PROVISIONS

Whenever there appears in this Agreement, or in the other Contract Documents made a part hereof, an indemnification provision within the purview of Chapter 725.06, Laws of Florida, the monetary limitation on the extent of the indemnification under each such provision shall be One Million Dollars or a sum equal to the total Contract price, whichever shall be the greater.

ARTICLE 11.08 UNLAWFUL PROVISIONS DEEMED STRICKEN

If this contract contains any unlawful provisions not an essential part of the Contract and which shall not appear to have a controlling or material inducement to the making thereof, such provisions shall be deemed of no effect and shall, upon notice by either party, be deemed stricken from the Contract without affecting the binding force of the remainder.

ARTICLE 11.09 LEGAL PROVISIONS DEEMED INCLUDED

Each and every provision of any law and clause required by law to be inserted in this Contract shall be deemed to be inserted herein, and the Contract shall be read and enforced as though it were included herein and if, through mistake or otherwise, any such provision is not inserted or is not correctly inserted, then upon application of either party the Contract shall forthwith be physically amended to make such insertion.

ARTICLE 11.10 DEATH OR INCOMPETENCY OF CONTRACTOR

In the event of death or legal incompetency of a Contractor who shall be an individual or surviving member of a contracting firm, such death or adjudication of incompetency

shall not terminate the Contract, but shall act as default hereunder to the effect provided in Article 9.01 hereof and the estate of the Contractor and his surety shall remain liable hereunder to the same extent as though the Contractor had lived. Notice of default, as provided in Article 9.01 hereof, shall not be required to be given in the event of such death or adjudication of incompetency.

ARTICLE 11.11 NUMBER AND GENDER OF WORDS

Whenever the context so admits or requires, all references herein in one number shall be deemed extended to and including the other number, whether singular or plural, and the use of any gender shall be applicable to all genders.

ARTICLE 11.12 ACCESS TO RECORDS

Representatives of Federal Agencies, if applicable, and the State of Florida shall have access to the work whenever it is in preparation of progress. On federally assisted projects the Federal Agency, the Comptroller General of the United States, or any authorized representative shall have access to any books, documents, papers, and records of the Contractor which are pertinent to the project for the purpose of making audit, examination, excerpts, and transcription thereof.

**SECTION 12
LABOR STANDARDS**

ARTICLE 12.01 LABOR STANDARDS

The Contractor shall comply with all of the regulations set forth in "Labor Standards Provisions for Federally Assisted Construction Contracts", which may be attached, and any applicable Florida Statutes.

ARTICLE 12.02 NOTICE TO LABOR UNIONS

If required, the Contractor shall provide Labor Unions and other organizations of workers, and shall post, in a conspicuous place available to employees or applicants for employment, a completed copy of the form entitled "Notice to Labor Unions or Other Organizations of Workers" attached to and made a part of this Agreement.

ARTICLE 12.03 SAFETY AND HEALTH REGULATIONS

The Contractor shall comply with the Department of Labor Safety and Health Regulations for construction promulgated under the Occupational Safety and Health Act of 1970 (PL 91- 596) and under Section 107 of the Contract Work Hours and Safety Standards Act (PL 91-54). Nothing in these Acts shall be construed to supersede or in any manner affect any worker's compensation law or statutory rights, duties, or liabilities of employers and employees under any law with respect to injuries, diseases, or death of employees arising out of, or in the course of, employment.

ARTICLE 12.04 EEO AFFIRMATIVE ACTION REQUIREMENTS

The Contractor understands and agrees to be bound by the equal opportunity requirements of Federal regulations which shall be applicable throughout the performance of work under this Contract. The Contractor also agrees to similarly

bind contractually each subcontractor. In policies, the Contractor agrees to engage in Affirmative Action directed at promoting and ensuring equal employment opportunity in the work force used under the Contract (and the Contractor agrees to require contractually the same effort of all subcontractors whose subcontractors exceed \$100,000). The Contractor understands and agrees that "Affirmative Action" as used herein shall constitute a good faith effort to achieve and maintain minority employment in each trade in the on-site work force used on the Contract.

ARTICLE 12.05 PREVAILING RATES OF WAGES

Florida's prevailing wage law was repealed effective April 25, 1979.

For Federally assisted projects, appropriate prevailing wage rate determinations are indicated on pages beginning with WR-1.

* * * * *

IN WITNESS THEREOF, the parties have hereunto set their hands and seals, and such of them as are corporation have caused these present to be signed by their duly authorized officers.

CITY OF TAMPA, FLORIDA

Jane Castor, Mayor
(SEAL)

ATTEST:

City Clerk

Approved as to Form:
The execution of this document was authorized
by Resolution No. _____

 Marcella T. Hamilton E/S
Marcella T. Hamilton, Assistant City Attorney

Contractor

By: _____
(SEAL)

Title:

ATTEST:

Witness

TAMPA AGREEMENT (ACKNOWLEDGMENT OF PRINCIPAL)

STATE OF _____)
) SS:
COUNTY OF _____)

For a Corporation:

STATE OF _____
COUNTY OF _____

The foregoing instrument was acknowledged before me this ____ of _____, 20__ by _____ of _____, a _____ corporation, on behalf of the corporation. He/she is ____ personally known or has ____ produced _____ as identification.

Notary

My Commission Expires:

For a Firm:

STATE OF _____
COUNTY OF _____

The foregoing instrument was acknowledged before me this ____ of _____, 20__ by _____ who signed on behalf of the said firm. He/she is ____ personally known or has ____ produced _____ as identification.

Notary

My Commission Expires:

PUBLIC CONSTRUCTION BOND

Bond No. (enter bond number) _____

Name of Contractor: _____

Principal Business Address of Contractor: _____

Telephone Number of Contractor: _____

Name of Surety (if more than one list each): _____

Principal Business Address of Surety: _____

Telephone Number of Surety: _____

Owner is The City of Tampa, Florida

Principal Business Address of Owner: _____ 306 E Jackson St, Tampa, FL 33602

_____ Contract Administration Department (280A4N)

Telephone Number of Owner: _____ 813/274-8456

Contract Number Assigned by City to contract which is the subject of this bond: _____

Legal Description or Address of Property Improved or Contract Number is: _____

General Description of Work and Services: _____

KNOW ALL MEN BY THESE PRESENTS That we, _____

(Name of Contractor)

as Principal, hereinafter called CONTRACTOR, of the State of _____, and

(Name of Surety)

a corporation organized and existing under and by virtue of the laws of the State of _____, and regularly authorized to do business in the State of Florida, as SURETY, are held and firmly bound unto the City of Tampa, a municipal corporation organized and existing under the laws of the State of Florida, hereinafter called Owner, in the penal sum of _____ Dollars and _____ Cents (\$ _____), lawful money of the United States of America, for the payment whereof well and truly to be made, we bind ourselves, our heirs, executors, and administrators, successors and assigns, jointly and severally, firmly by these presents.

THE CONDITION OF THIS BOND is that if Principal:

1. Performs the contract dated _____, _____, 20____, between Principal and Owner for construction of _____, the contract being made a part of this bond by reference, in the time and in the manner prescribed in the contract; and
2. Promptly makes payments to all claimants, as defined in Section 255.05(1) (Section 713.01), Florida Statutes, supplying Principal with labor, materials, or supplies, used directly or indirectly by Principal in the prosecution of the work provided for in the contract; and
3. Pays Owner all losses, damages, expenses, costs, and attorney's fees, including appellate proceedings, that Owner sustains because of a default by Principal under the contract; and
4. Performs the guarantee of all work and materials furnished under the contract for the time specified in the contract, then this bond is void; otherwise it remains in full force.
5. Contractor and Surety acknowledge that the Work for which this bond has been issued may be one of several such contract documents for a group of projects. This bond does not secure covenants to pay for or to perform design services survey or program management services. The Owner/Obligee is expected to reasonably account for damages that are caused to Owner with respect to Principal's (Contractor's) default in performance of the scope of the Work incorporated by reference into the bond, and notwithstanding any contractual or common law remedy permitted to Owner as against Contractor, the obligation of Surety for any damages under this bond shall be determined by the cost of completion of the Work less the contract balance unpaid upon default of Contractor for the Work plus liquidated damages at the rate of \$500.00 per day for delays by the Contractor and/or Surety in reaching substantial completion.
6. The notice requirements for claimants and conditions for entitlement to payment set forth in Section 255.05, Fla. Stat. and the limitations period to actions upon Section 255.05, Fla. Stat. bonds apply to claimants seeking payment from surety under this bond. Any action instituted by a claimant under this bond for payment must be in accordance with the notice and time limitation provisions in Section 255.05, Florida Statutes.
7. The Surety, for value received, hereby stipulates and agrees that no changes, extensions of time, alterations or additions to the terms of the contract documents or other Work to be performed hereunder, or the specifications referred to therein shall in any way affect its obligations under this bond, and it does hereby waive notice of any such changes, extensions of time, alterations or additions to the terms of the Contract or to Work or to the specifications.

8. The above SURETY states that it has read all of the Contract Documents made by the CONTRACTOR with the CITY, hereto attached, and the terms and conditions of the contract and work, and is familiar therewith and in particular those portions of the Agreement concerning the guaranty of such CONTRACTOR for a period of one year following the date of the final acceptance of the completed work under the Contract by the CITY, all of which this BOND includes.

DATED ON _____, 20__

(Name of Principal)

(Name of Surety)

(Principal Business Address)

(Surety Address)

By _____

By _____
(As Attorney in Fact)*

Title _____

Telephone Number of Surety

Telephone Number of Principal

Approved as to legal sufficiency:

Countersignature:

By Marcella T. Hamilton E/S
Marcella T. Hamilton, Assistant City Attorney

(Name of Local Agency)

(Address of Resident Agent)

By _____

Title _____

Telephone Number of Local Agency

*(As Attorney in Fact) attach Power of Attorney and Current Certificate with Original Signature

SPECIFICATIONS GENERAL PROVISIONS

SECTION 1 SCOPE AND INTENT

G-1.01 DESCRIPTION

The work to be done consists of the furnishing of all labor, materials and equipment, and the performance of all work included in this Contract.

G-1.02 WORK INCLUDED

The Contractor shall furnish all labor, superintendence, materials, plant, power, light, heat, fuel, water, tools, appliances, equipment, supplies, and other means of construction necessary or proper for performing and completing the work. He shall obtain and pay for all required permits. He shall perform and complete the work in the manner best calculated to promote rapid construction consistent with safety of life and property and to the satisfaction of the Engineer, and in strict accordance with the Contract Documents. The Contractor shall clean up the work and maintain it during and after construction, until accepted, and shall do all work and pay all costs incidental thereto. He shall repair or restore all structures and property that may be damaged or disturbed during performance of the work.

The cost of incidental work described in these General Provisions, for which there are no specific Contract Items, shall be considered as part of the overhead cost of doing the work and shall be included in the prices for the various Contract Items. No additional payment will be made therefor.

The Contractor shall provide and maintain such modern plant, tools, and equipment as may be necessary, in the opinion of the Engineer, to perform in a satisfactory and acceptable manner all the work required by this Contract. Only equipment of established reputation and proven efficiency shall be used. The Contractor shall be solely responsible for the adequacy of his plant and equipment, prior approval of the Engineer notwithstanding.

G-1.03 PUBLIC UTILITY INSTALLATIONS AND STRUCTURES

Public utility installations and structures shall be understood to include all poles, tracks, pipes, wires, conduits, house service connections, vaults, manholes, and all other appurtenances and facilities pertaining thereto whether owned or controlled by the City, other governmental bodies or privately owned by individuals, firms, or corporations, and used to serve the public with transportation, traffic control, gas, electricity, telephone, sewerage, drainage, water or other public or private property which may be affected by the work.

The Contract Documents contain data relative to existing public utility installations and structures above and below the ground surface. These data are not guaranteed as to their completeness or accuracy and it is the responsibility of the Contractor to make his own investigations to inform himself

fully of the character, condition and extent of all such installations and structures as may be encountered and as may affect the construction operations.

The Contractor shall protect all public utility installations and structures from damage during the work. Access across any buried public utility installation or structure shall be made only in such locations and by means approved by the Engineer. The Contractor shall so arrange his operations as to avoid any damage to these facilities. All required protective devices and construction shall be provided by the Contractor at his expense. All existing public utilities damaged by the Contractor which are shown on the Plans or have been located in the field by the utility shall be repaired by the Contractor, at his expense, as directed by the Engineer. No separate payment shall be made for such protection or repairs to public utility installations or structures.

Public utility installations or structures owned or controlled by the City or other governmental body which are shown on the Plans to be removed, relocated, replaced or rebuilt by the Contractor shall be considered as a part of the general cost of doing the work and shall be included in the prices bid for the various Contract Items. No separate payment shall be made therefor.

Where public utility installations or structures owned or controlled by the City or other governmental body are encountered during the course of the work, and are not indicated on the Plans or in the Specifications, and when, in the opinion of the Engineer, removal, relocation, replacement or rebuilding is necessary to complete the work under this Contract, such work shall be accomplished by the utility having jurisdiction or such work may be ordered, in writing by the Engineer, for the Contractor to accomplish. If such work is accomplished by the utility having jurisdiction it will be carried out expeditiously and the Contractor shall give full cooperation to permit the utility to complete the removal, relocation, replacement or rebuilding as required. If such work is accomplished by the Contractor, it will be paid for as extra work as provided for in Article 7.02 of the Agreement.

The Contractor shall, at all times in performance of the work, employ approved methods and exercise reasonable care and skill so as to avoid unnecessary delay, injury, damage or destruction of public utility installations and structures; and shall, at all times in the performance of the work, avoid unnecessary interference with, or interruption of, public utility services, and shall cooperate fully with the owners thereof to that end.

All City and other governmental utility departments and other owners of public utilities, which may be affected by the work, will be informed in writing by the Engineer within two weeks after the execution of the Contract or Contracts covering the work. Such notice will set out, in general, and direct attention to, the responsibilities of the City and other governmental

utility departments and other owners of public utilities for such installations and structures as may be affected by the work and will be accompanied by one set of Plans and Specifications covering the work under such Contract or Contracts.

In addition to the general notice given by the Engineer, the Contractor shall give written notice to all City and other governmental utility departments and other owners of public utilities of the location of his proposed construction operations, at least forty-eight (48) hours in advance of breaking ground in any area or on any unit of the work. This can be accomplished by making the appropriate contact with the "Underground Utility Notification Center for Excavators (Call Candy)".

The maintenance, repair, removal, relocation, or rebuilding of public utility installations and structures, when accomplished by the Contractor as herein provided, shall be done by methods approved by the Engineer.

SECTION 2 PLANS AND SPECIFICATIONS

G-2.01 PLANS

The Plans referred to in the Contract Documents bear the general project name and number as shown in the Notice To Bidders.

When obtaining data and information from the Plans, figures shall be used in preference to scaled dimensions, and large scale drawings in preference to small scale drawings.

G-2.02 COPIES FURNISHED TO CONTRACTOR

After the Contract has been executed, the Contractor will be furnished with five sets of paper prints, the same size as the original drawings, of each sheet of the Plans and five copies of the Specifications. Additional copies of the Plans and Specifications, when requested, may be furnished to the Contractor at cost of reproduction.

The Contractor shall furnish each of the subcontractors, manufacturers, and material suppliers such copies of the Contract Documents as may be required for his work.

G-2.03 SUPPLEMENTARY DRAWINGS

When, in the opinion of the Engineer, it becomes necessary to explain more fully the work to be done or to illustrate the work further or to show any changes which may be required, drawings known as Supplementary Drawings, with specifications pertaining thereto, will be prepared by the Engineer and five paper prints thereof will be given to the Contractor.

The Supplementary Drawings shall be binding upon the Contractor with the same force as the Plans. Where such Supplementary Drawings require either less or more than the estimated quantities of work, credit to the City or compensation therefor to the Contractor shall be subject to the terms of the Agreement.

G-2.04 CONTRACTOR TO CHECK PLANS AND DATA

The Contractor shall verify all dimensions, quantities, and details shown on the Plans, Supplementary Drawings, Schedules, Specifications, or other data received from the Engineer, and shall notify him of all errors, omissions, conflicts, and discrepancies found therein. Failure to discover or correct errors, conflicts or discrepancies shall not relieve the Contractor of full responsibility for unsatisfactory work, faulty construction or improper operation resulting therefrom nor from rectifying such conditions at his own expense. He will not be allowed to take advantage of any errors or omissions as full instructions will be furnished by the Engineer, should such errors or omissions be discovered. All schedules are given for the convenience of the Engineer and the Contractor and are not guaranteed to be complete. The Contractor shall assume all responsibility for the making of estimates of the size, kind, and quality of materials and equipment included in work to be done under the Contract.

G-2.05 SPECIFICATIONS

The specifications consist of four parts, the General Provisions, the Technical Specifications, the Special Provisions and the Contract Items. The General Provisions and Technical Specifications contain general requirements which govern the work. The Special Provisions and the Contract Items modify and supplement these by detailed requirements for the work and shall always govern, whenever there appears to be conflict.

G-2.06 INTENT

All work called for in the Specifications applicable to this Contract, but not shown on the Plans in their present form, or vice versa, shall be of like effect as if shown or mentioned in both. Work not specified in either the Plans or in the Specifications, but involved in carrying out their intent or in the complete and proper execution of the work, is required and shall be performed by the Contractor as though it were specifically delineated or described.

The apparent silence of the Specifications as to any detail, or the apparent omission from them of a detailed description concerning any work to be done and materials to be furnished, shall be regarded as meaning that only the best general practice is to prevail and that only material and workmanship of the best quality is to be used, and interpretation of these Specifications shall be made upon that basis.

SECTION 3 WORKING DRAWINGS

G-3.01 SCOPE

The Contractor shall promptly prepare and submit layout, detail and shop drawings to insure proper construction, assembly, and installation of the work using those materials and methods as hereafter specified under the Technical Specifications, Special Provisions and Contract Items.

These drawings shall accurately and distinctly present the following:

- a. All working and erection dimensions.
- b. Arrangements and sectional views.
- c. Necessary details, including complete information for making connections between work under this Contract and work under other Contracts.
- d. Kinds of materials and finishes.
- e. Parts listed and description thereof.

Drawings for mechanical equipment shall present, where applicable, such data as dimensions, weight and performance characteristics. These data shall show conformance with the performance characteristics and other criteria incorporated in the Plans and Specifications.

Each drawing shall be dated and shall contain the name of the project, Division number and description, the technical specifications section number, names of equipment or materials and the location at which the equipment or materials are to be installed. Location shall mean both physical location and location relative to other connected or attached material. The Engineer will return unchecked any submittal which does not contain complete data on the work and full information on related matters.

Stock or standard drawings will not be accepted for review unless full identification and supplementary information is shown thereon in ink or typewritten form.

The Contractor shall review all working drawing submittals before transmitting them to the Engineer to determine that they comply with requirements of the Specifications. Drawings which are incomplete or are not in compliance with the Contract Documents shall not be submitted for processing by the Engineer. The Contractor shall place his stamp of approval on all working drawings submitted to the Engineer to indicate compliance with the above.

G-3.02 APPROVAL

If the working drawings show departures from the Contract requirements, the Contractor shall make specific mention thereof in his letter of submittal; otherwise approval of such submittals shall not constitute approval of the departure. Approval of the drawings shall constitute approval of the subject matter thereof only and not of any structure, material, equipment, or apparatus shown or indicated.

The approval of drawings will be general and shall not relieve the Contractor of responsibility for the accuracy of such drawings, nor for the proper fitting and construction of the work, nor for the furnishing of materials or work required by the Contract and not indicated on the drawings. No work called for by working drawings shall be done until such drawings have been approved by the Engineer.

The procedure in seeking approval of the working drawings shall be as follows:

1. The Contractor shall submit four complete sets of drawings

and other descriptive data together with one copy of a letter of transmittal to the Engineer for approval. The letter of transmittal shall contain the name of the project, contract number, technical specifications section number, the name of the Contractor, a list of drawings with numbers and titles, and any other pertinent information.

2. Drawings or descriptive data will be stamped "Approved", "Approved Subject to Corrections Marked", or "Examined and Returned for Correction" and one copy with a letter of transmittal will be returned to the Contractor.

3. If a drawing or other data is stamped "Approved", the Contractor shall insert the date of approval on five additional copies of the document and transmit the five copies to the Engineer together with one copy of a letter of transmittal containing substantially the same information as described in Instruction 1. above.

4. If a drawing or other data is stamped "Approved Subject to Corrections Marked", the Contractor shall make the corrections indicated and proceed as in Instruction 3., above.

5. If a drawing or data is stamped "Examined and Returned for Correction", the Contractor shall make the necessary corrections and resubmit the documents as set forth in Instruction 1., above. The letter of transmittal shall indicate that this is a resubmittal.

The Contractor shall revise and resubmit the working drawings as required by the Engineer, until approval thereof is obtained.

SECTION 4 MATERIALS AND EQUIPMENT

G-4.01 GENERAL REQUIREMENTS

All materials, appliances, and types or methods of construction shall be in accordance with the Specifications and shall, in no event, be less than that necessary to conform to the requirements of any applicable laws, ordinances, and codes.

All materials and equipment shall be new, unused, and correctly designed. They shall be of standard first grade quality, produced by expert personnel, and intended for the use for which they are offered. Materials or equipment which, in the opinion of the Engineer, are inferior or of a lower grade than indicated, specified, or required will not be accepted.

The quality of Workmanship and Materials entering into the work under this Contract shall conform to the requirements of the pertinent sections, clauses, paragraphs, and sentences, both directly and indirectly applicable thereto, of that part of the Technical Specifications, whether or not direct reference to such occurs in the Contract Items.

Equipment and appurtenances shall be designed in conformity with ANSI, ASME, IEEE, NEMA and other

generally accepted standards and shall be of rugged construction and of sufficient strength to withstand all stresses which may occur during fabrication, testing, transportation, installation, and all conditions of operation. All bearings and moving parts shall be adequately protected against wear by bushings or other approved means and shall be fully lubricated by readily accessible devices. Details shall be designed for appearance as well as utility. Protruding members, joints, corners, gear covers, and the like, shall be finished in appearance. All exposed welds shall be ground smooth and the corners of structural shapes shall be mitered.

Equipment shall be of the approximate dimensions as indicated on the Plans or as specified, shall fit the spaces shown on the Plans with adequate clearances, and shall be capable of being handled through openings provided in the structure for this purpose. The equipment shall be of such design that piping and electrical connections, ductwork, and auxiliary equipment can be assembled and installed without causing major revisions to the location or arrangement of any of the facilities.

Machinery parts shall conform exactly to the dimensions shown on the working drawings. There shall be no more fitting or adjusting in setting up a machine than is necessary in assembling high grade apparatus of standard design. The equivalent parts of identical machines shall be made interchangeable. All grease lubricating fittings on equipment shall be of a uniform type. All machinery and equipment shall be safeguarded in accordance with the safety codes of the ANSI and applicable state and local codes.

G-4.02 MANUFACTURER

The names of proposed manufacturers, suppliers, material, and dealers who are to furnish materials, fixtures, equipment, appliances or other fittings shall be submitted to the Engineer for approval, as early as possible, to afford proper investigation and checking. Such approval must be obtained before shop drawings will be checked. No manufacturer will be approved for any materials to be furnished under this Contract unless he shall be of good reputation and have a plant of ample capacity. He shall, upon the request of the Engineer, be required to submit evidence that he has manufactured a similar product to the one specified and that it has been previously used for a like purpose for a sufficient length of time to demonstrate its satisfactory performance.

All transactions with the manufacturers or subcontractors shall be through the Contractor, unless the Contractor shall request, in writing to the Engineer, that the manufacturer or subcontractor deal directly with the Engineer. Any such transactions shall not in any way release the Contractor from his full responsibility under this Contract.

Any two or more pieces of material or equipment of the same kind, type or classification, and being used for identical types of service, shall be made by the same manufacturer.

G-4.03 REFERENCE TO STANDARDS

Whenever reference is made to the furnishing of materials or

testing thereof to conform to the standards of any technical society, organization or body, it shall be construed to mean the latest standard, code, specification or tentative specification adopted and published at the date of advertisement for proposals, even though reference has been made to an earlier standard, and such standards are made a part hereof to the extent which is indicated or intended.

Reference to a technical society, organization or body may be made in the Specifications by abbreviations, in accordance with the following list:

AASHTO for American Association of State Highway and Transportation Officials (formerly AASHO)
ACI for American Concrete Institute
AGMA for American Gear Manufacturer's Association
AFBMA for Anti-Friction Bearing Manufacturer's Association
AISC for American Institute of Steel Construction
AISI for American Iron and Steel Institute
ANSI for American National Standards Institute
ASCE for American Society of Civil Engineers
ASTM for American Society for Testing and Materials
ASME for American Society of Mechanical Engineers
AWS for American Welding Society
AWWA for American Water Works Association
AWPA for American Wood Preservers Association
CEMA for Conveyor Equipment Manufacturers Association
CIPRA for Cast Iron Pipe Research Association
IEEE for Institute of Electrical and Electronic Engineers
IPCEA for Insulated Power Cable Engineers Association
NEC for National Electrical Code
NEMA for National Electrical Manufacturers Association
SAE for Society of Automotive Engineers
SHBI for Steel Heating Boiler Institute
Fed.Spec. for Federal Specifications
Navy Spec. for Navy Department Specifications
U.L.,Inc. for Underwriters' Laboratories, Inc.

When no reference is made to a code, standard or specification, the Standard Specifications of the ANSI, the ASME, the ASTM, the IEEE, or the NEMA shall govern.

G-4.04 SAMPLES

The Contractor shall, when required, submit to the Engineer for approval typical samples of materials and equipment. The samples shall be properly identified by tags and shall be submitted sufficiently in advance of the time when they are to be incorporated into the work, so that rejections thereof will not cause delay. A letter of transmittal, in duplicate, from the Contractor requesting approval must accompany all such samples.

G-4.05 EQUIVALENT QUALITY

Whenever, in the Contract Documents, an article, material, apparatus, equipment, or process is called for by trade name or by the name of a patentee, manufacturer, or dealer or by reference to catalogs of a manufacturer or dealer, it shall be understood as intending to mean and specify the article, material, apparatus, equipment or process designated, or any

equal thereto in quality, finish, design, efficiency, and durability and equally serviceable for the purposes for which it is intended.

Whenever material or equipment is submitted for approval as being equal to that specified, the decision as to whether or not such material or equipment is equal to that specified shall be made by the Engineer.

Upon rejection of any material or equipment submitted as the equivalent of that specifically named in the Contract, the Contractor shall immediately proceed to furnish the designated material or equipment.

Neither the approval by the Engineer of alternate material or equipment as being equivalent to that specified nor the furnishing of the material or equipment specified, shall in any way relieve the Contractor of responsibility for failure of the material or equipment, due to faulty design, material, or workmanship, to perform the functions required of them by the Specifications.

G-4.06 DELIVERY

The Contractor shall deliver materials in ample quantities to insure the most speedy and uninterrupted progress of the work so as to complete the work within the allotted time. The Contractor shall also coordinate deliveries in order to avoid a delay in, or impediment of, the progress of the work of any related Contractor.

G-4.07 CARE AND PROTECTION

The Contractor shall be solely responsible for properly storing and protecting all materials, equipment, and work furnished under the Contract from the time such materials and equipment are delivered at the site of the work until final acceptance thereof. He shall, at all times, take necessary precautions to prevent injury or damage by water, freezing, or by inclemencies of the weather to such materials, equipment and work. All injury or damage to materials, equipment, or work resulting from any cause whatsoever shall be made good by the Contractor.

The Engineer shall, in all cases, determine the portion of the site to be used by the Contractor for storage, plant or for other purposes. If, however, it becomes necessary to remove and restack materials to avoid impeding the progress of any part of the work or interference with the work to be done by any other Contractor, the Contractor shall remove and restack such materials at his own expense.

G-4.08 TOOLS AND ACCESSORIES

The Contractor shall, unless otherwise stated in the Contract Documents, furnish with each type, kind or size of equipment, one complete set of suitably marked high grade special tools and appliances which may be needed to adjust, operate, maintain, or repair the equipment. Such tools and appliances shall be furnished in approved painted steel cases, properly labeled and equipped with good grade cylinder locks and duplicate keys.

Spare parts shall be furnished as specified.

Each piece of equipment shall be provided with a substantial nameplate, securely fastened in place and clearly inscribed with the manufacturer's name, year of manufacture, serial number, weight and principal rating data.

G-4.09 INSTALLATION OF EQUIPMENT

The Contractor shall have on hand sufficient proper equipment and machinery of ample capacity to facilitate the work and to handle all emergencies normally encountered in work of this character.

Equipment shall be erected in a neat and workmanlike manner on the foundations at the locations and elevations shown on the Plans, unless directed otherwise by the Engineer during installation. All equipment shall be correctly aligned, leveled and adjusted for satisfactory operation and shall be installed so that proper and necessary connections can be made readily between the various units.

The Contractor shall furnish, install and protect all necessary anchor and attachment bolts and all other appurtenances needed for the installation of the devices included in the equipment specified. Anchor bolts shall be as approved by the Engineer and made of ample size and strength for the purpose intended. Substantial templates and working drawings for installation shall be furnished.

The Contractor shall, at his own expense, furnish all materials and labor for, and shall properly bed in non-shrink grout, each piece of equipment on its supporting base that rests on masonry foundations. Grout shall completely fill the space between the equipment base and the foundation.

G-4.10 OPERATING INSTRUCTIONS

The Contractor, through qualified individuals, shall adequately instruct designated employees of the City in the operation and care of all equipment installed hereunder, except for equipment that may be furnished by the City.

The Contractor shall also furnish and deliver to the Engineer three complete sets for permanent files, identified in accordance with Subsection G-3.01 hereof, of instructions, technical bulletins and any other printed matter, such as diagrams, prints or drawings, containing full information required for the proper operation, maintenance, and repair, of the equipment installed and the ordering of spare parts, except for equipment that may be furnished by the City.

In addition to the above three copies, the Contractor shall furnish any additional copies that may be required for use during construction and start-up operations.

G-4.11 SERVICE OF MANUFACTURER'S ENGINEER

The Contract prices for equipment shall include the cost of furnishing a competent and experienced engineer or superintendent who shall represent the manufacturer and shall assist the Contractor, when required, to install, adjust, test and place in operation the equipment in conformity with the Contract Documents. After the equipment is placed in

permanent operation by the City, such engineer or superintendent shall make all adjustments and tests required by the Engineer to provide that such equipment is in proper and satisfactory operating condition, and shall instruct such personnel as may be designated by the City in the proper operation and maintenance of such equipment.

SECTION 5 INSPECTION AND TESTING

G-5.01 GENERAL

The Contractor's attention is hereby directed to Article 3.03 of the Agreement.

Inspection and testing of materials will be performed by the City unless otherwise specified.

For tests specified to be made by the Contractor, the testing personnel shall make the necessary inspections and tests and the reports thereof shall be in such form as will facilitate checking to determine compliance with the Contract Documents. Five copies of the reports shall be submitted and authoritative certification thereof must be furnished to the Engineer as a prerequisite for the acceptance of any material or equipment.

If, in the making of any test of any material or equipment, it is ascertained by the Engineer that the material or equipment does not comply with the Contract, the Contractor will be notified thereof and he will be directed to refrain from delivering said material and equipment, or to remove it promptly from the site or from the work and replace it with acceptable material, without cost to the City.

Tests of electrical and mechanical equipment and appliances shall be conducted in accordance with recognized test codes of the ANSI, ASME, or the IEEE, except as may otherwise be stated herein.

The Contractor shall be fully responsible for the proper operation of equipment during tests and instruction periods and shall neither have nor make any claim for damage which may occur to equipment prior to the time when the City formally takes over the operation thereof.

G-5.02 COSTS

All inspection and testing of materials furnished under this Contract will be performed by the City or duly authorized inspection engineers or inspection bureaus without cost to the Contractor, unless otherwise expressly specified.

The cost of shop and field tests of equipment and of certain other tests specifically called for in the Contract Documents shall be borne by the Contractor and such costs shall be deemed to be included in the contract price.

Materials and equipment submitted by the Contractor as the equivalent to those specifically named in the Contract may be tested by the City for compliance. The Contractor shall reimburse the City for the expenditures incurred in making

such tests on materials and equipment which are rejected for noncompliance.

G-5.03 INSPECTIONS OF MATERIALS

The Contractor shall give notice, in writing to the Engineer, sufficiently in advance of his intention to commence the manufacture or preparation of materials especially manufactured or prepared for use in or as part of the permanent construction. Such notice shall contain a request for inspection, the date of commencement and the expected date of completion of the manufacture or preparation of materials. Upon receipt of such notice the Engineer will arrange to have a representative present at such times during the manufacture as may be necessary to inspect the materials or he will notify the Contractor that inspection will be made at a point other than the point of manufacture, or he will notify the Contractor that inspection will be waived. The Contractor must comply with these provisions before shipping any material. Such inspection shall not release the Contractor from the responsibility for furnishing materials meeting the requirements of the Contract Documents.

G-5.04 CERTIFICATE OF MANUFACTURE

When inspection is waived or when the Engineer so requires, the Contractor shall furnish to him authoritative evidence in the form of Certificates of Manufacture that the materials to be used in the work have been manufactured and tested in conformity with the Contract Documents. These certificates shall be notarized and shall include copies of the results of physical tests and chemical analyses, where necessary, that have been made directly on the product or on similar products of the manufacturer.

G-5.05 SHOP TESTS OF OPERATING EQUIPMENT

Each piece of equipment for which pressure, duty, capacity, rating, efficiency, performance, function, or special requirements are specified shall be tested in the shop of the maker in a manner which shall conclusively prove that its characteristics comply fully with the requirements of the Contract Documents. No such equipment shall be shipped to the work until the Engineer notifies the Contractor, in writing, that the results of such tests are acceptable.

Five copies of the manufacturer's actual test data and interpreted results thereof, accompanied by a certificate of authenticity sworn to by a responsible official of the manufacturing company, shall be forwarded to the Engineer for approval.

The cost of the shop tests and of furnishing manufacturer's preliminary and shop test data of operating equipment shall be borne by the Contractor.

G-5.06 PRELIMINARY FIELD TESTS

As soon as conditions permit, the Contractor shall furnish all labor, materials, and instruments and shall make preliminary field tests of equipment. If the preliminary field tests disclose any equipment furnished under this Contract which does not comply with the requirements of the Contract Documents, the Contractor shall, prior to the acceptance tests, make all changes, adjustments, and replacements required.

TEMPORARY STRUCTURES

G-5.07 FINAL FIELD TESTS

Upon completion of the work and prior to final payment, all equipment and appliances installed under this Contract shall be subjected to acceptance tests as specified or required to prove compliance with the Contract Documents.

The Contractor shall furnish labor, fuel, energy, water and all other materials, equipment, and instruments necessary for all acceptance tests, at no additional cost to the City.

G-5.08 FAILURE OF TESTS

Any defects in the materials and equipment or their failure to meet the tests, guarantees or requirements of the Contract Documents shall be promptly corrected by the Contractor by replacements or otherwise. The decision of the Engineer as to whether or not the Contractor has fulfilled his obligations under the Contract shall be final and conclusive. If the Contractor fails to make those corrections or if the improved materials and equipment, when tested, shall again fail to meet the guarantees or specified requirements, the City, notwithstanding its partial payment for work, and materials and equipment, may reject the materials and equipment and may order the Contractor to remove them from the site at his own expense.

In case the City rejects any materials and equipment, then the Contractor shall replace the rejected materials and equipment within a reasonable time. If he fails to do so, the City may, after the expiration of a period of thirty calendar days after giving him notice in writing, proceed to replace such rejected materials and equipment, and the cost thereof shall be deducted from any compensation due or which may become due the Contractor under this Contract.

The City agrees to obtain other equipment within a reasonable time and the Contractor agrees that the City may use the equipment furnished by him without rental or other charges until the new equipment is obtained.

Materials or work in place that fails to pass acceptability tests shall be retested at the direction of the construction engineer all such retests shall be at the Contractor's expense. The rates charged shall be in accordance with the Department of Public Works current annual inspection contract which is available for inspection at the offices of the Department of Public Works.

G-5.09 FINAL INSPECTION

The procedures for final inspection shall be in accordance with the provisions of Article 4.07 of the Agreement. During such final inspections, the work shall be clean and free from water. In no case will the final estimate be prepared until the Contractor has complied with all the requirements set forth and the Engineer has made his final inspection of the entire work and is satisfied that the entire work is properly and satisfactorily constructed in accordance with the requirements of the Contract Documents.

SECTION 6

G-6.01 GENERAL

All false work, scaffolding, ladders, hoistways, braces, pumping plants, shields, trestles, roadways, sheeting, centering forms, barricades, drains, flumes, and the like, any of which may be needed in the construction of any part of the work and which are not herein described or specified in detail, must be furnished, maintained and removed by the Contractor, and he shall be responsible for the safety and efficiency of such works and for any damages that may result from their failure or from their improper construction, maintenance, or operation.

G-6.02 PUBLIC ACCESS

At all points in the work where public access to any building, house, place of business, public road, or sidewalk would be obstructed by any action of the Contractor in executing the work required by this Contract, the Contractor shall provide such temporary structure, bridges or roadway as may be necessary to maintain public access at all times. At least one lane for vehicular traffic shall be maintained in streets in which the Contractor is working. Street closure permits are required from the Department of Public Works.

The Contractor shall provide suitable temporary bridges, as directed by the Engineer, at street intersections when necessary for the maintenance of vehicular and pedestrian traffic.

Prior to temporarily cutting of access to driveways and garages, the Contractor shall give twelve (12) hours notice to affected property owners. Interruptions to use of private driveways shall be kept to a minimum.

G-6.03 CONTRACTOR'S FIELD OFFICE

The Contractor shall erect, furnish and maintain a field office with a telephone at the site during the entire period of construction. He or an authorized agent shall be present at this office at all times while his work is in progress. Readily accessible copies of both the Contract Documents and the latest approved working drawings shall be kept at this field office.

G-6.04 TEMPORARY FENCE

If, during the course of the work, it is necessary to remove or disturb any fence or part thereof, the Contractor shall, at his own expense, if so ordered by the Engineer, provide a suitable temporary fence which shall be maintained until the permanent fence is replaced. The Engineer shall be solely responsible for the determination of the necessity for providing a temporary fence and the type of temporary fence to be used.

G-6.05 RESPONSIBILITY FOR TEMPORARY STRUCTURES

In accepting the Contract, the Contractor assumes full responsibility for the sufficiency and safety of all temporary structures or work and for any damage which may result from their failure or their improper construction, maintenance, or operation and will indemnify and save harmless the City from

all claims, suits or actions and damages or costs of every description arising by reason of failure to comply with the above provisions.

SECTION 7 TEMPORARY SERVICES

G-7.01 WATER

The Contractor shall provide the necessary water supply at his own expense. He shall, if necessary, provide and lay necessary waterlines from existing mains to the place of using, shall secure all necessary permits and pay for all taps to water mains or hydrants and for all water used at the established rates.

G-7.02 LIGHT AND POWER

The Contractor shall provide, at his own expense, temporary lighting and power facilities required for the proper prosecution and inspection of the work. If, in the opinion of the Engineer, these facilities are inadequate, the Contractor will not be permitted to proceed with any portion of the work affected thereby.

G-7.03 SANITARY REGULATIONS

The Contractor shall prohibit and prevent the committing of nuisances on the site of the work or on adjoining property and shall discharge any employee who violates this rule.

Ample washrooms and toilet facilities and a drinking water supply shall be furnished and maintained in strict conformity with the law by the Contractor for use by his employees.

G-7.04 ACCIDENT PREVENTION

Precautions shall be exercised at all times for the protection of persons and property. The safety provisions of applicable laws, building and construction codes shall be observed. The Contractor shall comply with the U. S. Department of Labor Safety and Health Regulations for construction promulgated under the Occupational Safety and Health Act of 1970 (PL 91-596), and under Section 107 of the Contract Work. Hours and Safety Standards Act (PL 91-54), except where state and local safety standards exceed the federal requirements and except where state safety standards have been approved by the Secretary of Labor in accordance with provisions of the Occupational Safety and Health Act.

G-7.05 FIRST AID

The Contractor shall keep upon the site, at each location where work is in progress, a completely equipped first aid kit and shall provide ready access thereto at all times when men are employed on the work.

G-7.06 HEATING

The Contractor shall provide temporary heat, at his own expense, whenever required on account of work being carried on during cold weather and to prevent freezing of water pipes and other damage to the work.

SECTION 8

LINES AND GRADES

G-8.01 GENERAL

All work done under this Contract shall be constructed in accordance with the lines and grades shown on the Plans, or as given by the Engineer. The full responsibility for keeping alignment and grade shall rest upon the Contractor.

The Engineer will establish bench marks and base line controlling points. Reference remarks for lines and grades as the work progresses will be located to cause as little inconvenience to the prosecution of the work as possible. The Contractor shall so place excavation and other materials as to cause no inconvenience in the use of the use of the reference marks provided. He shall remove any obstructions placed by him contrary to this provision.

G-8.02 SURVEYS

The Contractor shall furnish and maintain, at his own expense, stakes and other such materials, and give such assistance, including qualified helpers, as may be required by the Engineer for setting reference marks. The Contractor shall check such reference marks by such means as he may deem necessary and, before using them, shall call the Engineer's attention to any inaccuracies. The Contractor shall, at his own expense, establish all working or construction lines and grades as required from the reference marks set by the Engineer, and shall be solely responsible for the accuracy thereof. He shall, however, be subject to the check and review of the Engineer.

The Contractor shall keep the Engineer informed a reasonable time in advance as to his need for line and grade reference marks, in order that they may be furnished and all necessary measurements made for record and payment with the minimum of inconvenience to the Engineer or of delay to the Contractor.

It is the intention not to delay the work for the establishment of reference marks but, when necessary, working operations shall be suspended for such reasonable time as the Engineer may require for this purpose.

G-8.03 SAFEGUARDING MARKS

The Contractor shall safeguard all points, stakes, grade marks, monuments and bench marks made or established on the work, bear the cost of reestablishing them if disturbed, and bear the entire expense of rectifying work improperly installed due to not maintaining or protecting or to removing without authorization such established points, stakes and marks.

The Contractor shall safeguard all existing and known property corners, monuments and marks adjacent to but not related to the work and, if required, shall bear the cost of reestablishing them if disturbed or destroyed.

G-8.04 DATUM PLANE

All elevations indicated or specified refer to the Mean Sea Level Datum of the U.S.C. & G.S. (N.O.S.) which is 0.80 feet above the Mean Low Water Datum of the U. S. Army

Corps of Engineers.

SECTION 9 ADJACENT STRUCTURES AND LANDSCAPING

G-9.01 RESPONSIBILITY

The responsibility for removal, replacement, relocation, repair, rebuilding or protection of all public utility installations, including poles, tracks, pipes, wires, conduits, house service connections, vaults, manholes, sewers, traffic control and fire alarm signal circuit installations and other appurtenances and facilities shall be in accordance with G-1.02 and G-1.03.

The Contractor shall also be entirely responsible and liable for all damage or injury as a result of his operations to all other adjacent public and private property, structures of any kind and appurtenances thereto met with during the progress of the work. The cost of protection, replacement in their original locations and conditions or payment of damages for injuries to such adjacent public and private property and structures affected by the work, whether or not shown on the Plans, and the removal, relocation, and reconstruction of such items called for on the Plans or specified shall be included in the various Contract Items and no separate payment will be made therefor. Where such public and private property, structures of any kind and appurtenances thereto are not shown on the Plans and when, in the opinion of the Engineer, removal or relocation and reconstruction is necessary to avoid interference with the work, payment therefor will be made as provided for extra work in Article 7.02 of the Agreement.

G-9.02 PROTECTION OF TREES

All trees and shrubs shall be adequately protected by the Contractor with boxes or otherwise and, within the City of Tampa, in accordance with ordinances governing the protection of trees. No excavated materials shall be placed so as to injure such trees or shrubs. Trees or shrubs destroyed by negligence of the Contractor or his employees shall be replaced by him with new stock of similar size and age, at the proper season, and at the sole expense of the Contractor.

Beneath trees or other surface structures, where possible, pipelines may be built in short tunnels, backfilled with excavated materials, except as otherwise specified, or the trees or structures carefully supported and protected from damage.

The City may order the Contractor, for the convenience of the City, to remove trees along the line of trench excavation. If so ordered, the City will obtain any permits required for removal of trees. Such tree removal ordered shall be paid for under the appropriate Contract Items.

G-9.03 LAWN AREAS

Lawn areas shall be left in as good condition as before the starting of the work. Where sod is to be removed, it shall be carefully removed and later replaced, or the area where sod has been removed shall be restored with new sod in the

manner described in the Technical Specifications section.

G-9.04 RESTORATION OF FENCES

Any fence, or part thereof, that is damaged or removed during the course of the work shall be replaced or repaired by the Contractor and shall be left in as good a condition as before the starting of the work. The manner in which the fence is repaired or replaced and the materials used in such work shall be subject to the approval of the Engineer. The cost of all labor, materials, equipment, and work for the replacement or repair of any fence shall be deemed included in the appropriate Contract Item or Items, or if no specific Item is provided therefor, as part of the overhead cost of the work, and no additional payment will be made therefor.

SECTION 10 PROTECTION OF WORK AND PUBLIC

G-10.01 TRAFFIC REGULATIONS

The Contractor shall arrange his work to comply with Article G-6.02. The work shall be done with the least possible inconvenience to the public and to that end the work may be confined by the Engineer to one block at a time.

G-10.02 BARRIERS AND LIGHTS

During the prosecution of the work, the Contractor shall put up and maintain at all times such barriers, and lights, as will effectually prevent accidents. The Contractor shall provide suitable barricades, red lights, "danger" or "caution" or "street closed" signs and watchmen at all places where the work causes obstructions to the normal traffic or constitutes in any way a hazard to the public. Such barriers and signs shall be constructed to State of Florida Department of Transportation standards and placed as recommended by the Traffic Division of the City's Department of Public Works.

No open fires will be permitted.

G-10.03 SMOKE PREVENTIONS

The Contractor shall use hard coal, coke, oil or gas as fuel for equipment generating steam. A strict compliance with ordinances regulating the production and emission of smoke will be required.

G-10.04 NOISE

The Contractor shall eliminate noise to as great an extent as practicable at all times. Air compressing plants shall be equipped with silencers and the exhaust of all gasoline motors or other power equipment shall be provided with mufflers. In the vicinity of hospitals and schools, special care shall be used to avoid noise or other nuisances. The Contractor shall strictly observe all local regulations and ordinances covering noise control.

Except in the event of an emergency, no work shall be done between the hours of 7:00 p.m. and 7:00 a.m., or on Sundays. If the proper and efficient prosecution of the work requires operations during the night, the written permission of the Engineer shall be obtained before starting such items of the work.

**SECTION 13
CLEANING**

G-10.05 ACCESS TO PUBLIC SERVICES

Neither the materials excavated nor the materials or plant used in the construction of the work shall be so placed as to prevent free access to all fire hydrants, valves or manholes.

G-10.06 DUST PREVENTION

The Contractor shall prevent dust nuisance from his operations or from traffic by keeping the streets sprinkled with water at all times.

G-10.07 PRIVATE PROPERTY

The Contractor shall so conduct the work that no equipment, material, or debris will be placed or allowed to fall upon private property in the vicinity of the work unless he shall have obtained the owner's written consent thereto and shall have shown this consent to the Engineer.

**SECTION 11
SLEEVES AND INSERTS**

G-11.01 COORDINATION

When the Contract requires the placing of conduits, saddles, boxes, cabinets, sleeves, inserts, foundation bolts, anchors, and other like work in floors, roofs, or walls of buildings and structures, they shall be promptly installed in conformity with the construction program. The Contractor who erects the floors, roofs, and walls shall facilitate such work by fully cooperating with the Contractors responsible for installing such appurtenances. The Contractor responsible for installing such appurtenances shall arrange the work in strict conformity with the construction schedule and avoid interference with the work of other contractors.

G-11.02 OPENINGS TO BE PROVIDED

In the event timely delivery of sleeves and other materials cannot be made and to avoid delay, the affected Contractor may arrange to have boxes or other forms set at the locations where the appurtenances are to pass through or into the floors, roofs, walls, or other work. Upon the subsequent installation of these appurtenances, the Contractor erecting the structure shall fill around them with materials as required by the Contract. The necessary expenditures incurred for the boxing out and filling in shall be borne by the Contractor or Contractors required to furnish the sleeves and inserts. Formed openings and later installation of sleeves will not be permitted at locations subject to hydrostatic pressure.

**SECTION 12
CUTTING AND PATCHING**

G-12.01 GENERAL

The Contractor shall do all cutting, fitting, or patching of his portion of the work that may be required to make the several parts thereof join and coordinate in a manner satisfactory to the Engineer and in accordance with the Plans and Specifications. The work must be done by competent workmen skilled in the trade required by the restoration.

G-13.01 DURING CONSTRUCTION

During construction of the work, the Contractor shall, at all times, keep the site of the work and adjacent premises as free from material, debris, and rubbish as is practicable and shall remove the same from any portion of the site if, in the opinion of the Engineer, such material, debris, or rubbish constitutes a nuisance or is objectionable.

The Contractor shall remove from the site all of his surplus materials and temporary structures when no further need therefor develops.

G-13.02 FINAL CLEANING

At the conclusion of the work, all erection plant, tools, temporary structures and materials belonging to the Contractor shall be promptly taken away, and he shall remove and promptly dispose of all water, dirt, rubbish or any other foreign substances.

The Contractor shall thoroughly clean all equipment and materials installed by him and shall deliver such materials and equipment undamaged in a bright, clean, polished, and new appearing condition.

**SECTION 14
MISCELLANEOUS**

G-14.01 PROTECTION AGAINST SILTATION AND BANK EROSION

The Contractor shall arrange his operations to minimize siltation and bank erosion on construction sites and on existing or proposed watercourses and drainage ditches.

G-14.02 EXISTING FACILITIES

The work shall be so conducted to maintain existing facilities in operation insofar as is possible. Work shall be scheduled to minimize bypassing during construction. Requirements and schedules of operations for maintaining existing facilities in service during construction shall be as described in the Special Provisions.

G-14.03 USE OF CHEMICALS

All chemicals used during project construction or furnished for project operation, whether herbicide, pesticide, disinfectant, polymer, reactant or of other classification, must show approval of either EPA or USDA. Use of all such chemicals and disposal of residues shall be in strict conformance with instructions.

SPECIFIC PROVISIONS

S-1.01 GENERAL

The Specific Provisions are intended as modifications or supplements to Instructions to Bidders, General Provisions, and the Tampa Agreement. All costs associated with the requirements set forth in the specific provisions shall be incidental to the items of work. No additional compensation will be provided. To the extent such provisions are not modified or supplemented herein, all provisions remain in full force and effect.

The work will be performed in various locations in the City's water service area and will be given out on a work order by work order basis. A separate set of plans or work directives will be provided for each work order.

The City of Tampa reserves the right to require the Contractor to change his "Contractor Superintendent" at any time.

S-2.01 DEFINITIONS

Add or amend the Definitions in Article 1.02 of the Agreement to these documents as follows:

"Department"

Add the following: "Whenever the word "Department" is used in the Contract Documents, it shall mean the "City of Tampa Water Department".

"Red-line Drawing" refers to drawing maintained by the Contractor depicting changes (as constructed) from original plans.

"Work Order Work" is defined as all work required to be performed pursuant to the terms of this contract and a Work Order issued in accordance with these Contract Documents.

S-4.01 DESCRIPTION OF WORK & WORK ORDERS

It is anticipated that the work to be performed under this Contract may include, but is not limited to, the following three (3) categories: Meter service installations, scheduled construction services, and non-scheduled construction services.

A. Meter Services. Install new potable and reclaimed water meter services in accordance with TWD Standard Meter Construction Details, to include tapping a water main, installing a City provided meter, and performing required restoration.

The Department expects 1,000 new meter service installations will be required annually - typically half each of long-side services (when the source water main is more than 15 ft. from the proposed meter location) and short-side services (source water main is 15 ft. or less from the proposed meter location). Meter installation work orders issued to a Contractor will depend on performance and timeliness of completion on previous meter installation work orders issued to that Contractor, to include satisfactory restoration.

B. Scheduled and C. Non-scheduled (Emergency) Work Orders shall include:

- i. repair and/or replacement of broken water mains;
- ii. removal and/or replacement or installation of isolated distribution or transmission water main valves;
- iii. potable or reclaimed water main relocations due to conflicts with construction proposed by others within the public rights-of-way;
- iv. restoration within the public rights-of-way for isolated water main repair jobs performed by others, or as directed by the Engineer;
- v. removal and/or replacement or installation of fire hydrant assemblies;
- vi. removal of below grade large DDCVA/Meter Vaults and/or installation of DDCVA/Large Meter Assemblies above- or below-grade per Water Department Standard Construction Details;
- vii. other miscellaneous water construction/repair projects required to maintain the water distribution and transmission systems.

The Contractor shall furnish all labor, materials and equipment for the accomplishment of all work as described in the Specifications, as shown on Plans if provided, and as directed by the Engineer in accordance with the expressed or obvious intent of the Contract. Work will be located throughout the City of Tampa and in adjacent portions of Hillsborough County where the City's water service area extends beyond City limits.

The City reserves the right to assign quantities of work to the contractor based on performance criteria, including but not necessarily limited to, the ability to meet acceptable schedules, the ability to satisfactorily complete leakage/pressure tests and other construction testing, and timeliness of satisfactory restoration.

Primary City concerns when awarding this contract are Contractor capability and commitment to performing and maintaining the service levels defined in Specific Provisions section S-4.02 Provisions For Time Sensitive Work Orders. City expectation is Contractor compliance with the specified service levels at least 98% of the time - for the six types of work orders listed therein.

Work Orders will typically originate from the Department's Distribution Division and will generally be isolated construction projects not associated with significant pipeline construction projects - such as individual meter service installations, single fire hydrant installations/removals/replacements, restoration jobs, valve installations and/or replacements, water distribution/transmission system components maintenance repairs or replacements, etc. As noted above, certain Work Orders will require expedited construction. Work Orders issued for construction other than the six expedited types described will not require expedited scheduling – completion time will instead be as agreed by the Contractor and City Engineer when the work order is issued.

Emergency Work Orders issued through the Contract will be in response to water main breaks, emergency valve replacements, or other water facilities emergency work required of the Department by others, as directed by the Engineer. Compensation for Emergency Work shall be provided based on Sub-Contractor cost and Contractor time (labor), equipment, and materials expended to accomplish the emergency construction required, as verified by the Engineer. The Contractor may include a 10% mark-up to Sub-Contractor cost. Payment for labor shall be based on actual hours expended for emergency construction, as reported in monthly certified payroll reports (including Contractor burden) provided to the City by the Contractor and will include a 15% OH&P mark-up. Compensation for equipment utilized for emergency construction shall be via applicable FHWA Rates taken from the current Rental Rate Blue Book for Construction and will include a 15% OH&P mark-up if not included in the Blue Book rate. Materials used for emergency construction will be compensated via invoices provided by the Contractor and will include a 15% OH&P mark-up.

Because Emergency Work Orders will generally require immediate response from the Contractor, initial notification for such work will be via telephone contact from an authorized Department representative. Following telephone notification, and as soon as is practicable, a confirming e-mail will be sent from the Department to the Contractor documenting the directed Emergency Work.

In the event of an emergency or urgent work, as identified by the Engineer or his designee, the Contractor will be required to respond to the request of the Engineer or his designated representative and mobilize as required or agreed.

Work Orders for non-Emergency construction services shall be issued to the Contractor in writing for each project requested by the City. All such notices shall indicate the date of issuance and include a cost estimate for the work required. Within seven (7) calendar days of receiving a Work Order (for non-expedited and non-Emergency construction) the Contractor shall provide the City a schedule for completing that work. Work Orders issued requiring expedited construction (i.e., requiring completion within 1-day to 2-weeks of release to the Contractor) will not require schedule submittals.

The Contractor's work schedule (when provided for non-expedited work orders) shall contain the detail and duration of all required work tasks, including delivery of as-built drawings. The City shall review the work schedule and return it for correction or review the work schedule and acknowledge its receipt.

Though the City will generate its own cost estimate for non-Emergency Work Orders, the Contractor shall review the plans and produce a cost estimate for all non-expedited Work Orders. If items are listed or shown for construction in the plans that are not in the Contract, or a price has not previously been agreed for those items, the Contractor shall propose costs to furnish and install the non-contract items.

Once the City acknowledges receipt of a schedule and cost estimate, it will become the official schedule for that work order and the City will issue the Notice to Proceed (a work order authorization) for that project. Upon receipt of a Notice to Proceed (work order authorization) from the City, the Contractor shall mobilize to the site and begin work within twenty (20) calendar days. For any work order with a total estimated value equal to or less than \$50,000 and for which the contractor does not mobilize to the site and begin work within twenty (20) calendar days of the start date delineated in the work order authorization (unless otherwise directed by the Engineer), the Department will assess liquidated damages of \$500.00 per day for each calendar day that their actual mobilization and start work date exceeds the aforementioned twenty (20) calendar day window.

Non-expedited Work Orders shall be constructed within the time frame outlined in the official work schedule for that work order. When the City determines that work on a particular work order is not progressing in a satisfactory manner and at a reasonable speed, it may, at its discretion, authorize the completion of the work by others. The Contractor will only be compensated for the work completed and the City is not obligated to the Contractor for uncompleted work remaining on the work order or contract

S-4.02 PROVISIONS FOR TIME SENSITIVE WORK ORDER WORK

When issued to the Contractor for construction, new meter installation, restoration, and fire hydrant (relocation, replacement, or isolated new installation) work orders will have expedited level of service (L.O.S.) requirements - for each, construction must be completed within a specified time. Maximum completion times allowed for each are as follows:

| | |
|--|---------|
| New Meter Installations | 2 weeks |
| Restoration - State roads | 1 day |
| Restoration - Streets, non-State roads | 7 days |
| Restoration - Driveways | 8 days |
| Restoration - Sidewalks | 10 days |
| Fire Hydrants | 10 days |

The Contractor is expected to meet service levels specified for these types of work orders at least 98% of the time.

S-4.03 EXTRA WORK

Compensation for Extra Work (i.e., construction work required to complete an issued work order but that is not included or addressed within the Contract) shall be in accordance with Tampa Agreement Article 7.02 EXTRA WORK. If City and Contractor cannot agree on acceptable unit rates or lump sum price for required Extra Work and compensation must instead be provided per sub-paragraph (c) in Article 7.02, labor rates shall be taken from the Contractor’s certified payroll, and equipment rates shall be taken from the current Rental Rate Blue Book for Construction Equipment.

S-4.04 AVAILABLE RESOURCES

The Contractor shall have sufficient resources, including but not necessarily limited to crews, subcontractors, equipment, and materials, to concurrently perform work on a minimum of three (3) separate Expedited Work Orders, one (1) Non-Expedited Work Order, and one (1) Emergency Work Order, while allocating a minimum of one crew per work order.

Each bidder will be required to present satisfactory evidence that he has the necessary competency, capability, credit, integrity, perseverance, and tenacity to complete this Contract as specified, to include providing information which delineates the number and type of each crew (pipe laying, testing, sodding, paving, etc.) to be allocated to this contract, the number of workers assigned to the crew and the company by whom they are employed. The inability to meet construction schedule deadlines for work order assignments shall be grounds for termination of the Contract.

S-5.01 LICENSES AND PERMITS

If not previously acquired by the Department, the Contractor must obtain at his own expense, all construction-related permits, licenses, or other legal authorization necessary for the execution of each project or work order issued by the Department. The Contractor must comply with all regulations, building and construction codes as may be required by law. Copies of all permits must be kept at the job site during construction. The Contractor shall comply with all the terms and requirements of the permits and will be held liable for the violation of any and all such permits.

Though generally not applicable to work orders to be issued through this Contract, where applicable (if project/work order work results in one acre or more of disturbed earth) the Contractor shall file a Notice of Intent (NOI) to access the generic NPDES permit administered by the Florida Department of Environmental Protection (FDEP). All document preparation, monitoring, reporting and other compliance with the NOI requirements shall

be the responsibility of the Contractor and no separate payment shall be made.

If Hillsborough County right-of-way permit is required it will be obtained by the City - or alternately, the Contractor will be directed to complete the simple pdf-application and approval process with Hillsborough County, typically completed in a day or two. If an FDOT right-of-way permit is required it will be obtained by the City - or, if FDOT notification only is sufficient, the Contractor will be directed to notify FDOT of the impending work. For work to be performed within City of Tampa limits, the contractor shall apply for a City of Tampa right-of-way permit. The Contractor shall provide traffic control plans to all right-of-way owners as required

In addition to the license requirements of the Instructions to Bidders and as stated above, the Contractor or Subcontractor performing the work on any water/reclaimed water systems must hold a current State Underground Utility and Excavation Contractor License issued by the Construction Industry Licensing Board of the State of Florida.

S-7.01 WORK DIRECTIVE CHANGE

A Work Directive Change is a written directive to the Contractor, issued on or after the date of the execution of the Agreement, and signed by the Engineer on behalf of the City, ordering an addition, deletion, or revision in the work, or responding to an emergency. A Work Directive Change will not change the contract price or the time for completion but is evidence that the parties expect that the change directed or documented by a Work Directive Change will be incorporated in a subsequently issued Change Order following negotiations by the parties as to its effect, if any, on the contract price or the time of completion.

Without invalidating the Agreement, additions, deletions, or revisions in the work may, at any time or from time to time, be authorized by a Change Order or a Work Directive Change. Upon receipt of any such document, the Contractor shall promptly proceed with the work involved.

S-8.01 ORDER AND TIME OF WORK

The work shall begin at such points as the Department shall designate and shall be prosecuted in the order it directs. This applies to both locations and items of construction. Where any of the work requires an interruption of service or water treatment plant operation, permission must be received from the Department and the work performed at times designated by it. The Contractor shall not be allowed to file claims for extra compensation of work prescribed by the Department. The Contractor shall make whatever arrangements are necessary and provide temporary lines and connections where designated by the Department.

S-9.01 DEFECTIVE MATERIALS

All pipe, fittings, valves, etc., except as defined herein, shall be furnished by the Contractor, and it shall be the responsibility of the Contractor to examine each item to ensure that it is new, unused, and in first class condition. Should a defect be discovered after the item has been placed in the trench, the replacement will be at the Contractor's expense. It will further be required of the Contractor that materials be hauled in a safe and careful manner to avoid possible damage. Should any damage be done, the Contractor shall be fully responsible. Materials may be stored along the installation routes in a manner acceptable to the Department. At no time shall materials for more than one week's work be stacked in the right-of-way. Materials shall not remain in the right-of-way during weekends, unless authorized by the Engineer. Contractor shall leave the site clean with no trash

when workers are not present.

Any materials that are furnished by the Department to the Contractor shall be obtained at the Department's storage yard. The Contractor shall furnish all labor and equipment necessary to load, transport, and unload the materials in the manner directed by the Department.

Materials accepted by the Contractor must be signed for by his authorized representative. After acceptance, the Contractor will be held accountable and responsible for the materials. No materials will be issued or returned without a written directive from the Department.

S-10.01 WORK PERFORMED ON SATURDAYS, SUNDAYS, LEGAL HOLIDAYS, OR AFTER REGULAR WORKING HOURS

With the exception of certain Emergency Work Orders issued, the work shall normally be discontinued on Saturdays, Sundays, all City and State designated holidays, and after regular working hours (7:30 A.M. to 4:00 P.M., Monday through Friday). Due to the work schedules of the City forces who may be involved, all work shall be conducted during normal work hours and days (Monday through Friday) and prior authorization must be requested by the Contractor for any work he feels is necessary to be accomplished on Saturdays, Sundays, or Holidays. Any overtime for Contractor convenience for weekend or holiday work requiring City forces will require reimbursement to the City by the Contractor for the cost of City personnel time required. The Contractor must request permission in writing at least 2 working days prior to performing work beyond regular work hours or on weekends or holidays as stated above. Written approval must be obtained from the Engineer.

When nighttime work has been approved or directed by the Engineer, it shall be the responsibility of the Contractor to provide adequate artificial lighting – additional compensation will be provided to the Contractor for said lighting, based on equipment rates in the current “Rental Rate Blue Book for Construction Equipment”. The Contractor shall be responsible for the safety of all employees during night work.

Jack and bore of FDOT maintained roadways must be started and completed during regular working hours of the FDOT's employees. Consequently, such operations must be initiated and completed in a continuous operation on Monday through Thursday when an FDOT inspector can be present.

S-11.01 COMMENCEMENT OF WORK

Upon receipt of the Contract Notice to Proceed, as specified in Tampa Agreement Article 4.01, the Contractor will be immediately authorized to receive work orders. The Contractor will be issued a separate work order authorization (notice to proceed for the work order) with each work order given to him. Non-Emergency work order authorizations shall stipulate the number of calendar days within which the Contractor must both commence and complete the work for the specific work order. The time for final completion shall be based on the approved work schedule for that specific work order.

Non-Expedited and Non-Emergency Work Order Work will not be allowed to commence until the Contractor has an approved project schedule, cost estimate and maintenance of traffic permit (if required).

S-12.01 PARTIAL PAYMENTS

The City shall have the option of making monthly partial payments on those work orders that exceed \$50,000.00. Payment of these partial payment requests shall be for the approved and accepted amount of work that the Contractor has accomplished in the previous month for that specific work order. The approved amount of work is defined as that amount of work associated with an active work order project which, in the opinion of the Engineer, is progressing at a satisfactory rate of completion. Satisfactory rate of completion is interpreted to mean that once a work order project is started by the Contractor, the job must be actively pursued to include site preparation, utility and agency coordination, installation of all pipe and appurtenances, restoration, clean up, all necessary testing, disinfecting, and final acceptance. Final acceptance shall include as-built drawings and necessary paperwork to close out the work order.

S-14.01 LAYOUT DATA

The City will provide horizontal and vertical control or reference points for each project, if required. From these control or reference points, the Contractor will set construction layout stakes and/or offsets necessary to complete the required work. All work shall be subject to field changes as directed by the Engineer. Compensation for construction layout will be included in the price of the various respective pay items for pipeline installation. Prior to commencement of construction, the Contractor shall obtain the Engineer's acceptance of the layout. It shall be the Contractor's responsibility to protect said stakes and/or offsets until (in the opinion of the Engineer) they have served their designated purpose. If re-staking and/or re-offsetting are required, the cost of re-staking and/or re-offsetting will be at the Contractor's expense.

S-15.01 CONFLICTS WITH PROPOSED WORK

It shall be the Contractor's responsibility to alert the Engineer to any conflicts or potential conflicts with the proposed work the day they are discovered, including but not limited to conflicts with existing utilities. Failure of the Contractor to review the job site and alert the Engineer to any conflicts shall relieve the Department from compensating the Contractor for any cost arising from any remedial action necessary to resolve conflict with the proposed work.

S-15.02 EXISTING UTILITIES

Any costs incurred as a result of damage to an "incorrectly" marked existing utility structure or appurtenances (except sanitary laterals – see S-20.01) are to be resolved with the owner of the damaged utility and are not the responsibility of the Water Department. "Incorrectly" marked (as defined in F.A.C. 556, the Underground Facility Damage Prevention and Safety Act) shall mean the hit location was more than 24" either side of the marking for 6" or smaller diameter pipe, or 24" outside of the marking (or double lines, if so marked) for pipes larger than 6" diameter.

S-16.01 TEMPORARY FACILITIES AND CONTROLS

A) Temporary Water Supply

As per Section G-7.01 of the General Provisions, temporary water required by the Contractor for the construction under this Agreement will be furnished by the City from the existing water system. The Contractor shall request temporary hydrant meters with backflow prevention devices when connecting to existing water system hydrants. A minimum of two business days are required to process temporary hydrant meter application. A security deposit for the meter is required. The deposit will be returned when the meter is returned to the City. City Crews will

install the meter with backflow-preventer on the hydrant. The Contractor shall make any necessary water supply connections at his own expense at a point designated by the City. The connections shall be maintained by the Contractor, who shall furnish all pipe, valves, and such other equipment as necessary. Temporary piping may run above ground, if done safely at the discretion of the Engineer. Otherwise, it must run underground and, in such manner, as to meet the approval of the Engineer. Temporary water shall only be used for approved purposes.

At the discretion of the Engineer, unnecessary waste of water after notification will be cause for use of water to be discontinued. After temporary lines have served their purpose, they shall be removed by the Contractor and all connections closed or plugged to the satisfaction of the City.

B) Temporary Sanitary Facilities

Necessary sanitary conveniences for the use of all employees shall be erected and maintained in a satisfactory and sanitary condition, per G-7.03. Upon completion of the work, the temporary facilities shall be removed leaving the premises clean.

S-17.01 MAINTENANCE AND RESTORATION OF JOB SITE

The Contractor shall conduct his operations in such a manner that will result in a minimum of inconvenience to occupants of adjacent homes and business establishments and shall provide temporary access as directed or as conditions in any specific location may require as determined by the Engineer. All restoration must be performed to an equal or better condition than that which existed prior to construction.

Good housekeeping on this project is extremely important and the Contractor will be responsible for keeping the construction site neat and clean, with debris being removed daily as the work progresses or as otherwise directed by the Engineer. Good housekeeping at the job site shall include removing all tools and temporary structures, dirt, rubbish, etc.; hauling all excess dirt, rock, etc. from excavations to a dump provided by the Contractor; and worksite clean-up shall be accomplished to the satisfaction of the Engineer. Immediately after construction is completed in an area or part thereof (including restoration), barricades, construction equipment and surplus and discarded materials shall be removed by the Contractor.

When the Engineer determines that the timely clean-up and restoration of the job site is not accomplished in a satisfactory manner, the Engineer may proceed to schedule and coordinate the necessary clean-up by others. The Contractor shall be back charged for these costs. If such action becomes necessary on the part of and in the opinion of the Engineer, the Department shall not be responsible for the inadvertent removal from the worksite of materials which the Contractor would not normally have disposed of had the Contractor completed the required clean-up.

At the completion of each workday, the Contractor shall fill all open trenches and pits. Trenches and pits may remain open only if the Contractor has obtained permission from the appropriate permitting agency and all protection and warning devices are in place in working order.

The Contractor shall replace all open-cut road pavements with a temporary compacted surface capable of supporting sustained vehicular loads as soon as possible once the trench or pit has been filled and compacted in 6-inch lifts. The temporary surface shall be maintained by the Contractor at the elevation of the adjacent road surfaces.

The Contractor is responsible for the security of all tools, materials and equipment required for this project and

must make all arrangements for safeguards he may deem necessary. The City will assume no liability for any such security or losses resulting from lack of security.

S-18.01 CONTRACTOR'S SCHEDULE & CSOPM

The Contractor shall submit a weekly schedule and clearance sequencing overview plan map (CSOPM) to the Engineer for review and approval. The weekly schedule shall reflect the work plan for all proposed water mains in the forthcoming week. The weekly schedule shall be provided to the Engineer by noon each Friday preceding the week that work is planned for. Unless other arrangements have been made between the Engineer and Contractor. The Clearance Sequencing Overview Plan Map (CSOPM) shall be highlighted to identify clearance or partial clearance sequence details for the project and note chlorination point(s), sample point(s), pressure test(s), and flushing stationing locations. The CSOPM shall be submitted for review prior to the start of the project and re-submitted as sequence adjustment are made. The Engineer shall advise the digital format style of the weekly schedule & CSOPM for submittal purposes.

S-19.01 USE OF EXPLOSIVES

Explosives shall not be used on the work except when authorized by the Engineer. If authorized, the use of explosives shall conform to laws or ordinances which may pertain to the use of same, and the utmost care will be exercised by the Contractor so as not to endanger life or property. The Contractor shall assume full responsibility in connection with the use of any explosives even though authorized. Explosives will not be stored within City limits.

S-20.01 SANITARY HOUSE CONNECTION CONFLICTS

Where sanitary house laterals are damaged or broken because of Contractor performed water construction, such laterals shall be restored by the Contractor according to the City of Tampa Sanitary Sewer Department's specifications and to the satisfaction of the Engineer.

If City Wastewater Department was contacted (notified of impending construction) a minimum of two (2) full business days prior to the excavation that resulted in damage to the facility, and if the facility hit was marked incorrectly (meaning the hit location was more than 24" either side of the marking for 6" or smaller diameter pipe, or 24" outside of the double lines marked (if double lines were marked) for pipe larger than 6" diameter), then the Contractor shall receive compensation for the replacement based on the applicable unit rates provided in the Contract.

If the damaged lateral was correctly marked in the field by City Wastewater forces, no extra compensation shall be paid for this work.

Additional compensation for damaged lateral replacement is contingent upon Contractor compliance with Sunshine State One Call of Florida (SSOCOF) guidelines for excavating. If determined that the Contractor's excavation was not in compliance with SSOCOF Guidelines, additional compensation will not be allowed for the lateral replacement.

Where laterals not denoted on plans nor field located, it shall be contractor responsibility to locate and avoid sewer laterals. Payments of sewer laterals may be authorized by Engineer where conflict of sewer laterals cannot be avoided.

S-23.02 PIPE INSTALLATION VIA HORIZONTAL DIRECTECIONAL DRILLING (HDD)

1.0 General

Directional drilling method is a multi-stage process that involves site preparation and restoration; equipment set-up; drilling a pilot hole as shown on an approved pilot bore plan, then enlarging the pilot hole to not larger than 1.5 times the outer diameter of the pullback pipe or pipe joint/coupling; and then pulling the product back through the drilled space. Installation shall be in accordance with the approved NASTT “HDD Good Practices Guideline, latest edition.

The General Contractor shall submit experience record, any design exception prior to installation, testing and disinfection plan, shop drawings (including not limited to all pipe, fittings, restraint joints and appurtenances), working drawings, bore plan, and records drawings to the City for review and approval.

The recommended Safe Pulling Force shall be supplied by the pipe manufacturer. The HDD Contractor shall utilize appropriate instrumentation to ensure that these loads are never exceeded.

The HDD Contractor shall have a minimum of three (3) years of experience and be licensed to provide trenchless services with the specified technology involving work of a similar nature. River crossing installations and cable, or phone duct installations are not considered similar installations due to the significantly different techniques involved. Only experienced personnel shall be used to install pipe. This includes the foreman, drill technician, and locator. A competent and experienced supervisor for the HDD Contractor must always be present during the actual drilling operations. A responsible representative who is thoroughly familiar with the equipment and type of work to be performed must always be in direct charge and control of the operation.

The HDD contractor shall have all applicable permits in hand prior to construction and all work shall be performed in the presence of the City representative.

1.1 Responsibility

The HDD Contractor shall be full responsible to perform the directional drilling work in strict conformance with the requirements of the agency in whose right-of-way or easement the work is being performed. Any special requirements of the agency such as insurance, flagmen, etc., shall be strictly adhered to during the performance of work. The special requirements shall be performed by the Contractor at no additional cost to the Owner.

It will be the Contractor's responsibility to locate all nearby utilities (including water/sewer service laterals) or other subsurface obstructions that may interfere with the work by contacting Sunshine One Call, excavating windows along the pipeline drill alignment, or other means.

All exploratory, entrance, exit and slurry pits shall be restored by the Contractor to the preconstruction condition or better at no additional cost. Care shall be taken to avoid unnecessary construction equipment traffic on sidewalks, driveways and green spaces. Damage to these areas shall be repaired by the Contractor, at his expense.

2.0 Directional Drilling Operations

The Directional Boring operation is to be operated in a manner to eliminate the discharge of water, drilling

mud, and cuttings to nearby water bodies or to the land areas involved during the construction process.

i) Pipe shall be handled, stored, and joined in accordance with manufacturer and City specifications.

ii) Survey and staking

a. Survey the entire drill path with entry and exit stakes placed at the appropriate locations as indicated on the drawings. A pipe marker (example PVC pipe/conduit) shall be inserted by the HDD Contractor at the beginning and end of each horizontal directional drill (HDD). The HDD Contractor shall provide a report and bore log, certified by an authorized company representative, to the Engineer for Construction indicating the horizontal and vertical location every 10 linear feet or less along the pipe.

iii) Excavation

a. Required directional drilling pits shall be excavated and maintained to minimum dimension. Said excavations shall be adequately barricaded, sheeted, braced and dewatered, as required, in accordance with the applicable portions of these Specifications.

b. Excavation adjacent to the road pavement shall be performed in a manner to adequately support these facilities.

c. Pre-excavate pipe entry and receiving areas to provide a gradual entry of the pipe without stress to the pipe or joints and to allow free movement into the bore hole at an acceptable depth. Carefully guide pipe in such a manner as to avoid deformation of, or damage to, the pipe. Do not use chains, cables or hooks inserted into the pipe ends. Handle the pipe in such a manner that the pipe is not damaged by dragging it over sharp and cutting objects. Slings or pipe rollers shall be used for pipe assembly during final product pull back.

iv) Guidance System

The guidance system shall:

a. use an electronic “walkover” tracking system, a Magnetic Guidance System (MGS), or a proven gyroscopic probe and interface for a continuous and accurate determination of the location of the drill head during the drilling operation.

b. be capable of tracking in any soil condition, including hard rock. It shall enable the driller to guide the drill head by providing immediate information on the tool face, azimuth (horizontal direction), and inclination (vertical direction);

c. be capable to be remotely steered and permit electronic monitoring of tunnel depth and location;

d. be accurate and calibrated to the manufacturer's specifications of the vertical depth. The system shall be accurate to within 2% vertically and two feet horizontally.

v) Every effort shall be made to maintain pipe installations at the proper alignment and at a depth of 42 inches (minimum) for potable water. Where deeper installations are shown on the plans, or required by the Owner, the HDD Contractor shall make such adjustments without additional cost to the Owner. Deviations from the plans may be made ONLY with the approval of City.

vi) The drilling mud shall be bentonite slurry or approved equal and shall be contained and disposed of in accordance with state/federal regulations and permit conditions. The Contractor shall install erosion and sedimentation control measures including, but not limited to, straw bales to prevent drilling mud from inadvertently spilling out of the entrance/exit pit and pressure relief vents.

vii) The pipe shall be installed in a manner that does not cause upheaval, settlement, cracking, frac-outs, movement, or distortion of surface features (include not limited to driveways, sidewalks, roads, etc.). If unexpected subsurface conditions are encountered during the bore, the procedure shall be stopped. The installation shall not continue until approval has been given by the City.

viii) Equipment shall be fitted with a permanent alarm system capable of detecting an electrical current. The system shall have an audible alarm to warn the operator if the drill head contacts electrified cables.

ix) Drill the pilot bore on the bore path with no deviations greater than 4% of the depth over the length of the bore. If the pilot does deviate from the bore path by more than 4% of depth over the length of the bore, the pilot must be pulled back and re-drilled from a location along the bore path before the deviation. The Contractor shall provide a means for accurately verifying the location of the pilot bore at certain points throughout the bore, when electronic detection alone is used, such device shall be accurate within 2 inches.

x) Upon completion of the pilot hole, submit a set of as-drilled records showing the pilot bore path plan and profile, as well as all directional survey reports as recorded during the drilling operation. Upon written approval (including time and date) by the Engineer of Record of the pilot bore location, back reaming (enlarging) of the bore opening can begin. Contractor shall maintain a daily project log of drilling operations and a guidance system log with a copy given to Engineer at completion of boring. As built drawings in AUTOCAD format with x, y, z

coordinates of the pipe shall be certified by the Contractor for accuracy and shall be provided to the Engineer within 48 hours after completion of the boring (see as-built plan provision).

xi) The carrier pipe shall be pulled back through using the wet insertion construction technique. At the HDD Contractor's option, the pipe may be installed ballasted with water during installation.

xii) When back reaming, the bore hole shall not exceed 1.5 times the outside diameter of the pipe or pipe joint/coupling for pipe up to 12 inches in diameter. For greater than 12-inch diameters the bore hole shall not exceed the maximum outside diameter of the pipe, plus six inches.

xiii) All nonmetallic pipes shall be installed with two insulated 10-gauge hard drawn copper clad steel core locating wires per City specifications. A continuity test shall be performed by the HDD Contractor in the presence of the City's representative. Wires shall be installed on terminal water lines leading to fire hydrant. Access to tracer wires at the hydrant valve shall be provided when the hydrant is more than 10 feet from the water main.

xiv) The annular space between the pipe and the bore hole shall be filled with an approved material (Bentonite or equal) to support and stabilize the pipe. If pressure grouting is used, caution should be exercised to insure that excess grout pressure does not distort or collapse the pipe.

xv) Pipe shall be installed in a manner that will insure that external loads will not subsequently cause a decrease of more than five percent in the vertical cross-section dimension. When changes in direction are necessary, these shall be accomplished gradually such that the ratio of bend radius to nominal pipe size is not less than 300.

xvi) In the case of a pull-back where the bore will be abandoned, the HDD Contractor shall inject an approved grout into the annular space. This action will be in conjunction with the removal of the bore tool to insure against collapse of the cover material

2.1 Reference Documents

Florida Department of Transportation (FDOT) Utility Accommodation Guide
National Utility Contractor's Association (NUCA)
North American Society for Trenchless Technology (NASTT)
Plastic Pipe Institute (PPI)

S-25.01 REQUIREMENTS FOR CONTROL OF THE WORK

Prior to the start of non-expedited or non-emergency work order work included in this contract, a preconstruction meeting will be held by the Engineer to be attended by the Contractor and representatives of the various utilities and others for the purpose of establishing a schedule of operations which will coordinate the work to be done under this contract with all related work to be done by others within the limits of the project. The contractor shall provide the baseline schedule for all items of work, key emergency contact list, project schedule of values, and submittal log.

For construction progress meetings the contractor shall provide a three-week schedule.

The Contractor shall conduct his operations in such a manner as will result in a minimum of inconvenience to occupants of adjacent homes and business establishments and shall provide temporary access as directed or as conditions in any specific location may require as determined by the Engineer.

S-26.01 ENVIRONMENTAL PROTECTION

The Contractor will be held liable for the violation of any and all environmental regulations and permit conditions. Violation citations related to environmental regulations and permit conditions carry civil penalties and, in the event of willful violation, criminal penalties. The fact that the permits are issued to the City does not relieve the Contractor in any way of his environmental obligations and responsibilities.

The Contractor shall evaluate and assess the impact of any adverse effects on the natural environment which may result from construction operations and shall operate to minimize pollution of air, ground or surface waters and vegetation and afford the neighboring community the maximum protection during and upon completion of the construction. The Contractor shall comply with Article 14.01 of the General Provisions and submit a plan to the Engineer for review and acceptance prior to implementation of the plan. Such plan can be combined with other control plan submittals and shall address protective measures to be taken along the route during pipeline construction.

The Contractor shall take sufficient precautions to prevent pollution of streams, lakes, ponds and other water sources with fuels, oils, bitumen, calcium hypochlorite (HTH) or other harmful materials. The Contractor shall conduct and schedule operations to avoid pollution or siltation of streams, lakes, etc., including the use of silt barriers, straw bales, or other related control methods, as outlined in the FDOT Standard Specifications. Where there is a high potential for erosion, the Contractor shall not expose, by construction operations, a larger area of erosive land at any one time than the minimum necessary for efficient construction operations, and the duration of exposure of the uncompleted construction to the elements shall be as short as practicable. Erosion control features shall be constructed concurrently with other work and at the earliest practicable time.

S-27.01 USE OF PRIVATE PROPERTY

In accordance with Section 10, Paragraph G-10.07 of the General Provisions, all construction activities required to complete Work Order Work in accordance with the plans and specifications shall be confined to public rights-of-way, unless the Contractor makes specific arrangements with private property owners for his use of their property. The City assumes no responsibility for damage to private property in such instances. The Contractor is responsible for protection of private property abutting the work areas on this project.

S-28.01 TREE REMOVAL

The Contractor shall be extremely careful and make all efforts to preserve existing trees, plants, and shrubs within

the construction area.

Any existing trees, plants, and shrubs to be removed shall be with the prior approval of the Engineer and in accordance with City of Tampa Landscape Ordinance No. 89-262, latest edition, or the requirements of the local agency responsible for overseeing those activities. Separate payment shall be made to the Contractor for the tree removal under the appropriate pay item.

S-29.01 STANDARD DETAILS

In addition to the various details applicable to the project included in the plans, there are Standard Details of the City of Tampa Water Department that shall apply to this work. The details that are to supplement those shown in the plans are included herein.

S-30.01 MAINTENANCE OF CONTINUOUS WATER SERVICE

At the conclusion of every workday, the Contractor is responsible for ensuring that all water services within his effective work area are in service. If a water customer contacts the Department to advise that they have no water service and it is determined to be within the Contractor's work area, the Contractor will be notified of the interrupted service through the Department dispatcher and/or inspection division. Upon notification, the Contractor must mobilize to the site and reinstate the customer's water service.

If the Contractor fails to mobilize his forces to make the repairs, the Department will mobilize its own forces to reinstate the customer's water services. In this event, the Contractor shall be charged a five hundred dollar (\$500.00) flat rate fee plus actual direct department costs for labor, materials, and equipment used to reinstate the water service. This five-hundred-dollar fee and Department cost will be charged for each additional service reinstated. The amount charged will be deducted from the Contractor's payment.

S-31.01 SHUTDOWNS

Unless otherwise approved by the Engineer in an emergency situation, scheduled shutdowns may only occur on Mondays, Tuesdays and Wednesdays. The Contractor shall notify the Engineer at least two weeks in advance of the need for a scheduled shutdown.

Where connections are made to the existing mains, or where other occurrences require a shutdown, the Contractor shall work with the City to perform the work necessary to complete the shutdown. The City will make every effort in advance to perform pre-valve shutdowns, but there are no guarantees as to whether or not all valves will properly seat in order to guarantee a complete shutdown. In the event of an emergency, the Contractor shall immediately notify the City.

S-34.01 ASBESTOS REMOVAL

The Contractor shall secure the services of a State of Florida licensed asbestos abatement contractor for the performance of any and all work involving the cutting, removal, transportation and proper disposal of asbestos containing materials.

The asbestos abatement work must be performed by a contractor having not less than 10 years of experience in work of this type and magnitude. The asbestos abatement contractor must submit a listing of the last ten (10)

projects performed with the name and telephone number of a contact person. Additionally, the asbestos abatement contractor shall submit a certified letter indicating compliance with the following:

- a) Job supervisor's names and confirmation of State of Florida licensure, valid for the period of the contract.
- b) Pollution Liability Insurance with a minimum limit of \$1,000,000 bodily injury and property damage combined single limit each occurrence to cover its liability as an asbestos abatement contractor. Such policy shall be issued in accordance with the insurance specifications contained in this bid, including naming the City and Contractor (if different than the asbestos abatement contractor) as additional insureds.
- c) Statements indicating no pending lawsuits.
- d) An acceptable disposal facility is required. Documentation must be submitted to the City Engineer that the proposed disposal site is approved to receive and deposit asbestos waste materials. After deposition, receipts must be submitted to the Engineer to demonstrate that the waste was properly disposed of.

The submittal shall be in sufficient detail to show compliance with the above qualification specification.

S-36.01 CONTRACTOR'S PRESENCE

The Contractor or his authorized representative shall be present at the job site at all times while the work is in progress. Contractor shall make readily accessible copies of both the Contract Documents and the latest approved working drawings at the job site.

S-37.01 FIELD OFFICE

Field offices will not be required per G6.03 as most of the work required will be in City streets.

S-38.01 TEMPORARY FENCING

Whenever temporary site fencing is required per contract plans, the fencing will be added to the project through a change order. Temporary fencing is not required on every work order.

S-38.02 PERMANENT FENCE RESTORATION

When required to remove permanent fence to permit construction, the Contractor shall remove and store fence to prevent damage. Subsequent to construction, the Contractor shall restore fence to its original location and condition, repair damaged fence, or replace with applicable in-kind material.

Whenever permanent fencing is agreed by the Engineer to be removed by the Contractor to facilitate water construction, fence removal and restoration shall be performed per G-9.04 – except compensation will be provided to the Contractor, based on either 1) the fencing sub-contractor's invoice, plus 15% OH&P; or, 2) if fence restoration is executed by the Contractor, compensation shall be provided in accordance with Specific Provision S-4.04. The fence restoration will be added to the project through a Work Directive Change (WDC).

Permanent fencing is not required on every work order.

S-40.01 AS-BUILT PLANS

During construction, installation and testing, records shall be created and maintained of all work performed. All changes or adjustments (red-lines) made in the work should be incorporated into the As-Built.

The City will provide the Contractor with the approved contract drawings in AutoCAD Civil 3D or other electronic format for use in creating the As-Built. The Contractor/Surveyor is responsible and shall verify the AutoCAD version to be utilized with the City prior to starting the survey for the record drawings.

At the discretion of Engineer, As-Built can be requested with a deadline for submittal at any point during construction. Failure to meet the deadline will result in the halt of construction. Construction shall continue by Engineer's discretion.

A) AutoCAD drawing requirements

- i) The As-Built shall be geo-referenced to the Florida State Plane Coordinate System, Traverse Mercator, West Zone of 1983 in feet (NAD 83-90 FT). All vertical elevations shall be referenced to the North American Vertical Datum of 1988 (NAVD88),
- ii) All x, y, and z coordinates [Easting(x), Northing (y), and Elevation (z)] shall be shown to two decimal (0.xx') accuracy,
- iii) All drawing revision shall be consistent in style, color, line weight, font, symbol and layer with the original construction documents.

B) As-Built requirements

The As-Built shall indicate the pipe size (diameter), material type, and AWWA/ASTM/ASNSI classification. It also shall include the x, y, and z coordinates at:

- i) All water fittings,
- ii) Water meter service (corporation stop, center of meter box top, center of housekeeping pad if applicable),
- iii) The operating nut of all valves and hydrants,
- iv) Top of pipe for one side where the pipe goes into the valve spigot,
- v) Top center of pipe at no greater than every fifty (50) feet interval along all water pipelines (transmission and distribution) including the beginning and ending connection points to the TWD water system,
- vi) Top center of the casing ends for pipes installed via Jack and Bore construction method,
- vii) Top center of the pipe at all excavated locations for pipes installed via pipe bursting,

- viii) Top center of the pipe at the limits and all excavated locations of the abandoned pipe method of abandonment must also be provided on the As Built,
- ix) The pipe locations as contained in the bore log for pipes installed via Horizontal Directional Drill (HDD). Bore log must also be submitted.
- x) Other utilities found not shown on approved constructions plans,
- xi) Cross-section details where utilities cross.

C) Deliverables

As-Built shall be Signed and Sealed by a Registered Surveyor and/or Professional Engineer (P.E.) licensed to practice in the State of Florida. If certified by a Surveyor, P.E. will sign off Stating that the As-Built were reviewed by the engineer, verifying that the P.E. or Engineer have some involvement in inspecting the work.

1) Partial Submittals

a. Partial submittal for DEP clearance:

Per agreed (city and contractor) upon construction sequence and prior to connecting to the City of Tampa Water Distribution System. All installed mains shall be cleared to meet DEP clearance requirements.

Partial submittal for DEP clearance shall include:

- i) One (1) digitally signed and sealed 11"x17" (paper size) in portable document format (PDF) of partial As-Built drawing.

b. Partial submittal for As-Built payment application:

The contractor shall submit 30, 60, & 90 percent (%) As-Built in correlation to project completion percentage (%). Payment shall be disbursed upon Engineer's review and acceptance of the partial As-Built. Payments shall be released in increments of 30, 60, & 90 percent (%) in association to As-Built submittal percentage (%).

Partial submittal for As-Built payment shall include:

- i) One (1) digitally signed and sealed 11"x17" (paper size) in portable document format (PDF) of partial As-Built drawing;
- ii) One (1) unlocked AutoCAD (Civil 3D preferred) drawing electronic file (.dwg format) with an updated and accurate pipe network(s) that depicts field conditions.

2) Final Submittal

The Contractor shall submit "final submittal" to the Engineer for review within three (3) weeks to the agreed (City & Contractor) upon substantial completion date. The

“Certificate of Completion” and/or Final payment for the project shall be withheld until the Engineers review and acceptance of the Final As-Builts.

The final submittal shall include:

- i) One (1) digitally signed and sealed 11”x17” (paper size) in portable document format (PDF) of final As-Built drawing;
- ii) One (1) unlocked AutoCAD (Civil 3D preferred) drawing electronic file (.dwg format) with an updated and accurate pipe network(s) that depicts field conditions;
- iii) One (1) Signed & Sealed 11”x17” (paper size) hard copy.

S-50.01 HYDROSTATIC TESTING

1. Pressure Testing

All newly laid pipe, including fittings, valves and service lines shall be pressure tested in accordance with latest version of AWWA Standard C600 (for Ductile Iron Pipe) and C605 (for PVC) and these documents where applicable.

The Contractor shall provide all necessary equipment and instrumentation (pressure gauges, volume gauges, hoses, pumps, test pipe, test fittings, etc.) required for flushing and testing of the piping systems. Pressure gauges shall be marked in graduated increments that do not exceed 2 pounds per square inch. Gauges used to measure the volume of water necessary to raise post-test line pressure back to the highest pressure achieved during the test duration will be marked in graduated increments which do not exceed 5 ounces. If requested by the Engineer, the Contractor shall furnish to the Engineer certified test data for the pressure gauges and recorders used on hydrostatic equipment. Water for test purposes will be supplied by the Contractor. Tests shall be made in sections not to exceed 1/2 mile. Testing shall be conducted in the presence of and to the satisfaction of the Engineer as a condition precedent to the approval and acceptance of the system. Not less than 3 working days a written request shall be given prior to start of such tests, and such testing shall not be scheduled until preliminary testing by the Contractor has indicated that the test section is ready for testing. The written request shall include bacteriological test date, partial as-built depicting chlorine injection point(s), sample point(s), and pipe length totals. The schedule and procedures for testing shall be determined by the Contractor and reviewed with the Engineer prior to testing.

The duration of each pressure test shall be at least 2 hours with a minimum test pressure more than 150 psi. At no time shall the test or line pressure exceed 190 psi. If required by the Engineer, pump test equipment will be equipped with pressure relief valves pre-set to 190 psi. Each valved section of pipe shall be slowly filled with water and a pump shall be connected to the low point of the section being tested.

Before conducting the test, the Contractor shall backfill all pipe and reaction blocking unless the Engineer directs certain joints or connections to be left uncovered. When reaction blocking is provided, the pressure test shall not be made until adequate curing time for the blocking has been allowed.

Before application of the test pressure, all air shall be expelled from the pipe. To accomplish this, taps will be made, if necessary, at points of highest elevation and afterward tightly stopped with tapered brass plugs, all at the Contractor's expense.

At the end of the 2-hour test period, the Contractor will be required to pump the lines back up to the highest pressure obtained during the duration of the test period.

Pressure tests shall be made between valves to demonstrate the ability of the valve to sustain pressure. All piping systems shall be tested in accordance with these test methods in addition to any other tests required by local plumbing codes or building authorities.

Throughout the duration of the test, the Contractor is required to maintain a minimum pressure more than 150 psi. The Contractor is advised that, should the test pressure fall to or below 150 psi any time during the 2 hour test, the test will be considered invalid and a retest will be required. Therefore, it is advised that the Contractor should pump water into the line as the test pressure approaches 150 psi.

The Contractor is warned that pressure testing against existing valves is done at his own risk. Failure of these valves to hold test pressure will not relieve the Contractor of the pressure testing.

All exposed pipe, fittings, valves, and joints shall be carefully examined for leaks. Any cracked or defective pipe, fittings, valves, or other appurtenances discovered because of the pressure test shall be removed and replaced with acceptable material. All leaking or defective joints shall be repaired, corrected, or replaced. After all necessary replacements and corrections have been made; the test shall be repeated to the satisfaction of the Engineer.

If the pipeline fails the pressure test twice, then the Contractor shall be required to retest the pipeline and provide to the Department certification by a Professional Engineer registered in the State of Florida, that the pipeline has passed the test in accordance with these standards prior to the Water Department scheduling and witnessing the pressure test.

2. Leakage Tests for Pipelines

Concurrently with pressure testing, pipelines shall be subjected to leakage tests.

Leakage measurements shall not be started until a constant test pressure has been established more than 150 psi.

The duration of each leakage test shall be at least 2 hours and the test pressure shall be as specified for the pressure tests. Leakage is defined as the quantity of water that must be supplied into the pipeline or section thereof to maintain the established test pressure after the air in the pipeline has been expelled and the pipe filled with water plus that volume of water required at the conclusion of the test to bring the line pressure back up to the highest pressure obtained during the duration of the test period.

For DIP, the maximum allowable leakage shall not exceed the number of gallons per hour (gph) as determined by the following formula:

$$L = \frac{SD\sqrt{P}}{148,000}$$

Where:

- L= testing allowance (makeup water), in gph
- S= length of pipeline tested, in feet
- D= nominal diameter of the pipe, inches
- P= average test pressure during the leakage test, in psi (gauge)

For PVC, the maximum allowable limits for Leakage shall not exceed the number of gallons per hour (gph) as determined by the formula:

$$Q = \frac{LD\sqrt{P}}{148,000}$$

Where:

- Q = Quantity of makeup water, allowable leakage, in gph
- L = Length of pipe section being tested, in feet
- D = Nominal diameter of pipe, in inches
- P = Average test pressure during the test, in psi (gauge)

When leakage exceeds the allowable limit, the defective pipe or joints shall be located and repaired. All visible leaks are to be repaired regardless of the amount of leakage. If the defective portions cannot be located, the Contractor shall remove and reconstruct as much of the work as is necessary until the leakage is within the allowable limits. Such corrective work or damages to other parts of the work because of such work shall be at the Contractor's expense.

Leakage detection at mechanical joints shall be stopped by tightening the gland (not to exceed required torque) and leaking slip joints shall be cut out and entirely replaced or if permission is given by the Engineer, it may be repaired by a suitable clamp. Any split, cracked or defective pipe, fittings, valves, or hydrants discovered as a result of this test shall be removed and replaced by the Contractor with sound material and then test shall be repeated.

If the pipeline fails the test twice, the Contractor shall be required to retest the pipeline and provide the Department certification by a Professional Engineer registered in the State of Florida that the pipeline has passed the test in accordance with these standards.

S-50.02 DISINFECTION AND BACTERIOLOGICAL TESTING

A. Scope

All new, temporary, and re-introduced water lines must be cleaned, disinfected, flushed, and must pass tests for chlorine concentration and coliform absence before being put into use.

Upon completion of satisfactory cleaning, chlorination, and flushing, water samples for bacteriological tests shall be taken. A clearance package including but not limited to as-built, pressure test results, and bacteriological test results shall be submitted to the City representative. Once accepted and approved by City and/or DEP, City representative will give written approval or disapproval prior to placing the main into service.

B. Contractor Responsibility

The contractor shall furnish properly trained personnel, appropriate equipment and materials, and transportation, for the disinfection of domestic water systems, fire lines, and any lines connected to them. The contractor shall post warning signs at each outlet. The contractor shall be prepared to dispose of wasted water in a way that will cause no harmful effects. The contractor shall be prepared to measure chlorine residuals, at both high and low range, using appropriate techniques. The City representative will oversee the work and must verify all pertinent chlorine residuals.

A minimum of 3 working days' notice must be given to the City representative prior to the chlorination procedure.

C. Disinfectant (Chlorinating Agent)

- i) Either sodium hypochlorite solution or liquid chlorine (gas) is acceptable.
- ii) Any other disinfectant must receive prior approval from the City.

D. Disinfection Procedure

1. Preliminary Preparation

- i) During the entire construction period, care shall be taken to keep the inside of pipes and appurtenances as clean as possible.
- ii) A suitable service cock or valve within three (3) feet of the supply line shall be installed to introduce the disinfecting agent into the lines. The line(s) to be treated shall be isolated from the rest of the distribution system with cross-connection control devices or other appropriate isolation devices.
- iii) After final pressure tests and before chlorination, each fixture or outlet shall be flushed until the flow shows only clear water.

2. Disinfection / Chlorination

The system must be full of potable water and under "Main" pressure during chlorination. The Contractor shall disinfect the water mains in accordance with the applicable section of the latest AWWA Specification C-651, as summarized below. The Contractor, if directed, shall use the method specified by the Engineer.

A. Slug Method

The slug method consists of: a) Completely filling the main in order to remove air pockets, b) flushing the main with a velocity of not less than 2.5 feet per second (fps) in order to remove particles, c) at a point not more than 10 feet downstream of the water source flushing the new

main; chlorine is to be continuously injected for a sufficient period to develop a solid column or "slug" of chlorinated water, d) the slug of chlorinated water is to move through the main exposing all interior surfaces to a chlorine concentration of approximately 100 mg/L for at least a 3 hour period.

B. Continuous Feed Method

The continuous feed method consists of: a) completely filling the main to remove air pockets, b) flushing the main with a velocity not less than 2.5 fps, c) at a point not more than 10 feet downstream of the water source flushing the new main; chlorine is to be injected in the new main at a constant rate sufficient to establish a 25 mg/L chlorine concentration throughout the main, d) Note table for amount of sufficient chlorine required for each 100 foot section of pipe of various diameters.

| Pipe Diameter (in) | 100 % Chlorine (lb) | 1% Chlorine Solution (gal) |
|--------------------|---------------------|----------------------------|
| 4 | 0.013 | 0.16 |
| 6 | 0.030 | 0.36 |
| 8 | 0.054 | 0.65 |
| 10 | 0.085 | 1.02 |
| 12 | 0.120 | 1.44 |
| 16 | 0.217 | 2.60 |

The chlorinated water shall be retained in the main for at least 24 hours and warning signs must be posted at each outlet, during which time valves and hydrants in the treated section shall be operated to ensure disinfecting the appurtenances.

At the end of the 24-hr holding period, the treated water in all portions of the main shall have a residual of not less than 10 mg/L of free chlorine. If it does not, the test should be repeated.

E. Bacteriological testing

After disinfection, final flushing, and before watermain is placed into service, representative water samples shall be taken by contractor or his designated personnel and submitted to an approved State Department of Health Laboratory for the detection of coliform and non-coliform bacteria. The results shall be submitted to the Engineer. A successful test result will indicate the absence of total E. Coli in 100 ml. The standard laboratory test method requires 24 hours to complete. Occupancy and/or clearance approval will take at least that long. If the laboratory analysis shows the water is unsafe to use, (presence of any coliform bacteria) disinfection procedure and analysis shall be repeated until the standards are met.

The number of samples required shall be as indicated in AWWA C-651 Section 5 which follows:

1. Standard Condition – Two consecutive sets of acceptable samples shall be collected from the new main for total coliform analysis using either following options:

Option A: Take an initial set of samples then resample again at least 24 hours apart

Option B: Let the treated water sit in the main for at least 24 hours without any use, take an initial sample then resample again after a minimum of 15 minutes while sampling taps are left running.

In either option, both sets of samples must pass for the main to be approved for release. Sets of samples shall be collected from every 1200 ft of the new water main, plus one set from the end of the line and at least one set from each branch.

2. Special Condition - If trench water, quantities of dirt, or debris has entered the new main during construction. Samples shall be taken of water that stood in the new main for at least 24 hours after final flushing has been completed. Bacteriological samples shall be taken at intervals of approximately 200 ft and shall be identified by location.

Due to the requirements from the FDEP, the Contractor may be required to remobilize to the job site thirty to forty-five days after the samples have been cleared to perform necessary meter transfers and/or cut and plugs.

After completing the testing and sterilizing and regardless of ground conditions, all sample taps and corporation stops shall be removed from the pipe and replaced with tapered brass plug.

S-60.01 TREE PROTECTION

The Contractor is responsible to protect all trees (public and private) within the vicinity of proposed construction in accordance with Chapter 13 of the City of Tampa code, and standards therein. Excavation within the protective radius of trees requires root pruning with the appropriate equipment to assure roots are severed clean at the approved radius. Excavations shall not be performed in tree root zones without cutting roots cleanly -- cutting roots via backhoe is unacceptable. Branch or root pruning is not authorized without prior approval from the City of Tampa Planning and Development Department, Natural Resource Section, and if authorized shall be completed by a certified arborist and in compliance with ANSI A-300 tree trimming standards.



Page 1 of 2 –DMI Payment
City of Tampa – DMI Sub-(Contractors/Consultants/Suppliers) Payments
(FORM MBD-30)

[] Partial [] Final

Contract No.: _____ WO#,(if any): _____ Contract Name: _____

Contractor Name: _____ Address: _____

Federal ID: _____ Phone: _____ Fax: _____ Email: _____

GC Pay Period: _____ Payment Request/Invoice Number: _____ City Department: _____

Total Amount Requested for pay period: \$ _____ Total Contract Amount(including change orders):\$ _____

Type of Ownership - (F=Female M=Male), BF BM = African Am., HF HM = Hispanic Am., AF AM = Asian Am., NF NM = Native Am., CF CM = Caucasian S = SLBE

| Type | Trade/Work Activity | Total Sub Contract Or PO Amount | Amount Paid To Date | Amount To Be Paid For This Period |
|-----------------------|---------------------|---------------------------------|------------------------------------|-----------------------------------|
| []Sub []Supplier | | | Amount Pending Previously Reported | Sub Pay Period Ending Date |
| Federal ID | | | | |
| | | | \$ | \$ |
| | | | | |
| | | | \$ | \$ |
| | | | | |
| | | | \$ | \$ |
| | | | | |
| | | | \$ | \$ |
| | | | | |
| | | | \$ | \$ |
| | | | | |
| | | | \$ | \$ |
| | | | | |

(Modifying This Form or Failure to Complete and Sign May Result in Non-Compliance)

Certification: I hereby certify that the above information is a true and accurate account of payments to sub – contractors/consultants on this contract.

Signed: _____ Name/Title: _____ Date: _____



Page 2 of 2 – DMI Payment

Instructions for completing The DMI Sub-(Contractors/Consultants/ Suppliers) Payment Form (Form MBD-30)

This form must be submitted with all invoicing or payment requests where there has been subcontracting rendered for the pay period. If applicable, after payment has been made to the subcontractor, “Waiver and Release of Lien upon Progress Payment”, “Affidavit of Contractor in Connection with Final Payment”, or an affidavit of payment must be submitted with the amount paid for the pay period. The following will detail what data is required for this form. The instructions that follow correspond to the headings on the form required to be completed. **(Modifying or omitted information from this form my result in non-compliance).**

- **Contract No.** This is the number assigned by the City of Tampa for the bid or proposal.
- **W.O.#** If the report covers a work order number (W.O.#) for the contract, please indicate it in that space.
- **Contract Name.** This is the name of the contract assigned by the City of Tampa for the bid or proposal.
- **Contractor Name.** The name of your business.
- **Address.** The physical address of your business.
- **Federal ID.** A number assigned to a business for tax reporting purposes.
- **Phone.** Telephone number to contact business.
- **Fax.** Fax number for business.
- **Email.** Provide email address for electronic correspondence.
- **Pay Period.** Provide start and finish dates for pay period. (e.g. 05/01/13 – 05/31/13)
- **Payment Request/Invoice Number.** Provide sequence number for payment requests. (ex. Payment one, write 1 in space, payment three, write 3 in space provided.)
- **City Department.** The City of Tampa department to which the contract pertains.
- **Total Amount Requested for pay period.** Provide all dollars you are expecting to receive for the pay period.
- **Total Contract Amount (including change orders).** Provide expected total contract amount. This includes any change orders that may increase or decrease the original contract amount.
- **Signed/Name/Title/Date.** This is your certification that the information provided on the form is accurate.
- **See attached documents.** Check if you have provided any additional documentation relating to the payment data. Located at the bottom middle of the form.
- **Partial Payment.** Check if the payment period is a partial payment, not a final payment. Located at the top right of the form.
- **Final Payment.** Check if this period is the final payment period. Located at the top right of the form.

The following instructions are for information of any and all subcontractors used for the pay period.

- **(Type) of Ownership.** Indicate the Ethnicity and Gender of the owner of the subcontracting business or SLBE.
- **Trade/Work Activity.** Indicate the trade, service, or material provided by the subcontractor.
- **SubContractor/SubConsultant/Supplier.** Please indicate status of firm on this contract.
- **Federal ID.** A number assigned to a business for tax reporting purposes. This information is critical in proper identification of the subcontractor.
- **Company Name, Address, Phone & Fax.** Provide company information for verification of payments.
- **Total Subcontract Amount.** Provide total amount of subcontract for subcontractor including change orders.
- **Amount Paid To Date.** Indicate all dollars paid to date for the subcontractor.
- **Amount Pending, Previously Reported.** Indicate any amount previously reported that payments are pending.
- **Amount To Be Paid for this Period.** Provide dollar amount of dollars requested for the pay period.
- **Sub Pay Period Ending Date.** Provide date for which subcontractor invoiced performed work.

Forms must be signed and dated or will be considered incomplete. The company authorized representative must sign and certify the information is true and accurate. Failure to sign this document or return the document unsigned can be cause for determining a company is in non-compliance of Ordinance 2008-89.

If any additional information is required or you have any questions, you may call the Minority Business Development Office at (813) 274-5522.

0 1 2 3 4 5 6 7 8

Sign Information

Building a Better Tampa

**David L. Tippin Water Treatment Facility
Caustic Soda Piping Improvements**

Project provides for Improvements at the David L. Tippin Water Treatment Facility to Improve the reliability and safety of the Sodium Hydroxide System of the water distribution system within the facility.

\$TBD investment
Scheduled for completion in TBD 2014

TBD

Colors

Blue: Sherwin Williams Naval SW6244
Green: Sherwin Williams Center Stage SW 6920
White: Sherwin Williams Pure White SW7005

Font

Franklin Gothic

SIGN EXAMPLE ONLY GRAPHIC TO BE DEVELOPED BY CONTRACTOR

not to scale

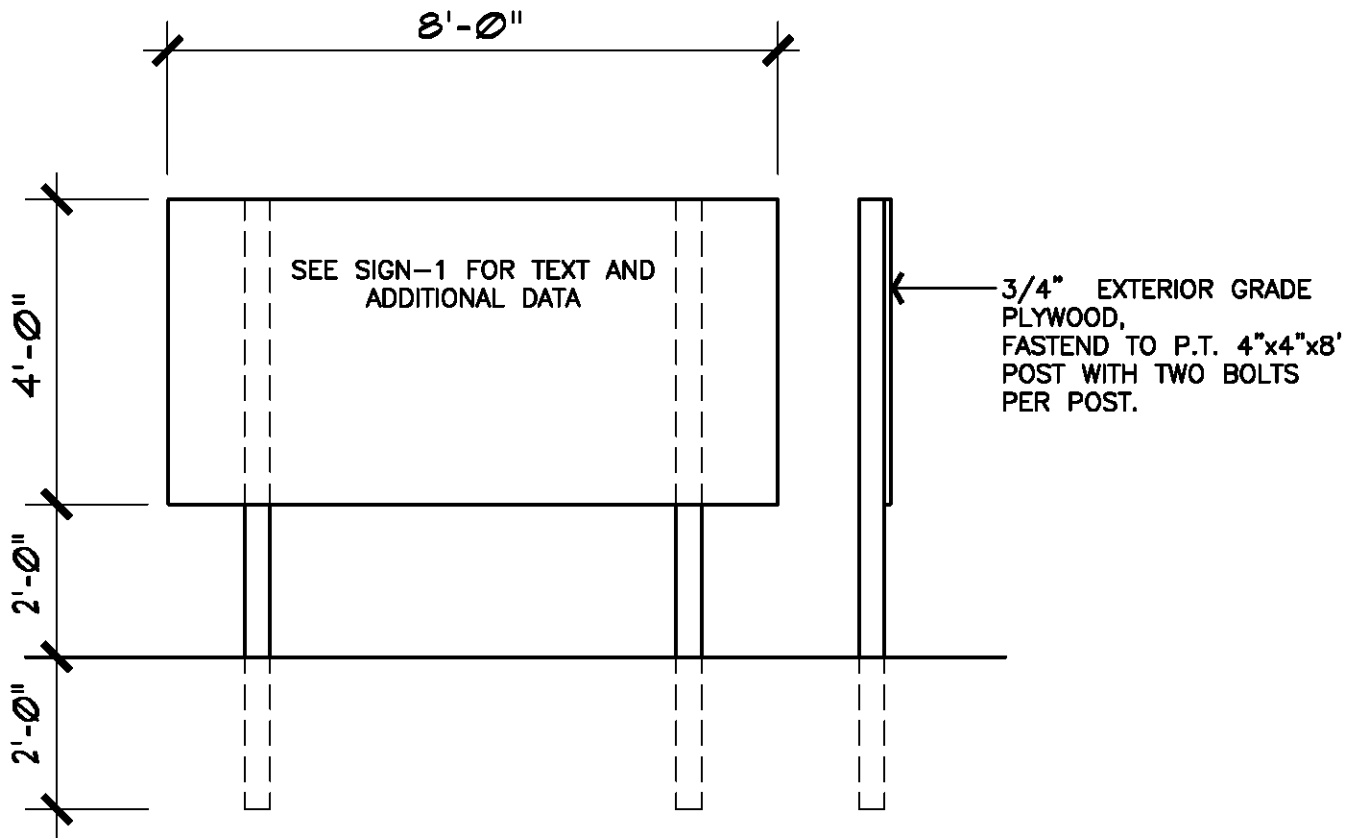

CONTRACT PAY ITEMS

C1.00 General

The Contractor shall receive and accept the compensation provided in the Proposal and the Agreement as full payment for furnishing all materials and all labor, tools and equipment, for performing all operations necessary to complete the work under the Agreement, and also in full payment for all loss or damages arising from the nature of the work, or from any discrepancy between the actual quantities of work and quantities herein estimated by the Engineer, or from the action of the elements or from any unforeseen difficulties which may be encountered during the prosecution of the work until the final acceptance by the Department.

It is the intent of these contract documents that any cost for which compensation is not directly provided by a bid item shall be prorated and included in the bid item for which they are required. Failure of the Contractor to follow this procedure shall be basis for rejection of his bid.

The prices stated in the Bid Proposal include all costs and expenses for taxes, labor, equipment, commissions, transportation charges and expenses, patent fees and royalties, labor for handling material during inspection together with any and all other costs and expenses for performing and completing the work as shown on the plans and specified herein. The basis of payment for any item at the unit price shown in the Proposal shall be in accordance with the description of that item in this Section.

No separate payment will be made for the following items; the cost of such work shall be included in the applicable contract pay items of work, including separate mobilization/demobilization charges for compliance with FDEP or any other agency:

1. Separate mobilization charges for each work order except as noted in Section C9.96;
2. Clearing and grubbing;
3. Excavation, including necessary pavement/slab removal;
4. Shoring and sheeting as required by OSHA trench excavation safety standards unless specifically provided for in a pay item;
5. Dewatering and proper disposal of all water unless specifically provided for in a pay item;
6. Backfill and proper compaction, including suitable fill;
7. Grading;
8. Replacement or restoration of paved or unpaved roadways, grass and shrubbery plots outside of established pay limits;
9. Temporary facilities and controls during construction such as water/sanitary facilities, traffic control, informational signs and environmental protection, unless specifically provided for in a pay item;
10. Providing and maintaining silt barriers for drainage structures and silt fences for the duration of the project;
11. Removing and legally disposing of waste material due to construction, including but not limited to valve boxes that need to be removed from abandoned water mains;
12. Cleanup and restoring the job site to its original condition, which includes but is not necessarily limited to restoring the ground surface to its original grade;
13. Testing and placing system in operation, including re-mobilization for FDEP testing;
14. Any material and equipment required to be installed and used for the tests;
15. Maintaining the existing quality of service during construction, including flushing mains that are

- cleared but not put into service after the bacteriological (bac-T) tests are complete;
16. Repair of sanitary sewer house laterals that were properly marked (see Specific Provision S-20.01)
 17. Repair of water services damaged during construction;
 18. Adjusting new or existing water meter boxes to grade which are affected by construction;
 19. Appurtenant work as required for a complete and operable system;
 20. Coordination with all utilities and all Federal, State and Local agencies;
 21. Cutting of existing or new pipe for purposes of abandonment or installation of new pipe, valves or fittings;
 22. Tree trimming as required by the City of Tampa Parks Department or any other agency unless specifically provided for as a contract item;
 23. Verification of pipe elevation as stated in Section 8 of the General Provisions and Section S-23.01 the Specific Provisions;
 24. Repair of private irrigation systems damaged during construction;
 25. Furnishing and installing suitable temporary fences, as directed by the Engineer, to adequately secure areas protected by a permanent fence when that permanent fence must be removed. The temporary fence shall remain in place until the permanent fence is replaced;
 26. Furnishing and installing all HDPE MJ adapters or HDPE flanged adapters;
 27. Maintaining red-line drawings of changes to construction plans, to be submitted for FDEP clearance;
 28. Furnishing record drawings based on the redline drawings in AutoCAD 2015 or higher and one set of drawings on paper. The City will provide the AutoCAD plans used for the design. **Final Payment will not be made for work orders until as-built drawings are received and accepted by the City.**
 29. Furnishing and installing polyethylene encasement per Standard Detail 2.05 for all buried ductile iron pipe, all fittings and tapping sleeves.

The Contractor's attention is again called to the fact that the quotations for the various items of work are intended to establish a total price for completing the work in its entirety. Should the Contractor feel that the cost for any item of work has not been established by the Proposal or Contract Pay Items, he shall include the cost for that work in some other applicable bid item, so that his proposal for the project does reflect his total price for completing the work in its entirety.

The Contractor may be authorized to receive payment after each work order is complete, approved, accepted, and administratively processed by the City.

The City shall have the option of making monthly partial payments on those work orders that exceed \$50,000.00. Payment of these partial payment requests shall be for the approved and accepted amount of work that the Contractor has accomplished in the previous month for that particular work order. The approved amount of work is defined as that amount of work associated with an active work order project which, in the opinion of the Engineer, is progressing at a satisfactory rate of completion. Satisfactory rate of completion is interpreted to mean that once a work order project is started by the Contractor, the job must be actively pursued to include site preparation, utility and agency coordination, installation of all pipe and appurtenances, restoration, clean up, testing, disinfection, and final acceptance.

Following final payment by the City, the Contractor shall maintain the surface of the unpaved trenches, shrubbery, fences, sod, and other surfaces disturbed for a period of six (6) months thereafter and shall maintain the repaved areas, curbs, gutters and sidewalks, trees, if replaced by the Contractor, for one (1) year after acceptance. The cost of maintaining the restored areas is considered incidental to the cost of

restoring the areas disturbed by the Contractor. These costs shall be prorated and included in the cost for the bid item for which it is required.

The quantities for payment under this Agreement shall be determined by actual measurement of the completed items, in place, ready for service and accepted by the City, in accordance with the applicable method of measurement therefore contained herein. A representative of the Contractor shall witness all field measurements.

All work shall be in accordance with the Technical Specifications and Standard Details herein. All materials shall be in accordance with the Material Specifications herein.

C2.00 Pipeline Installation

C2.10 Ductile Iron and PVC Pipe via Open-cut

The Contractor shall provide all labor, equipment, and materials to furnish and install the ductile iron pipe or PVC pipe.

Furnishing and/or installing ductile iron or PVC pipe shall include, but may not be limited to:

1. Furnishing all construction layouts as outlined in Section S-14.01 and S-23.01;
2. Field locating all utilities to confirm horizontal and vertical location in areas of possible conflict;
3. Furnishing all labor equipment and materials to excavate the trench;
4. Maintaining the trench which shall include dewatering and sheeting and bracing as required by OSHA or as directed by the Engineer standards unless specifically provided for in a pay item;
5. Cleaning dirt and foreign material from within pipe and bell;
6. Beveling field-cut joints and pipe shorts;
7. Furnishing and installing EPDM gaskets for all DIP and PVCP;
8. Furnishing and installing Department approved pipe and any pipe shorts as part of the pipeline;
9. Furnishing and installing Department approved pipe in casing pipe when shown on the plans;
10. Installing push-on joint restraint gaskets for DIP as shown on the plans or as directed by the Engineer (furnishing push-on restraint gaskets will be compensated under appropriate pay items);
11. Furnishing and installing blue polyethylene encasement for D.I. Pipe and Fittings, per standard Detail 2.05;
12. Furnishing and installing 2-, 4-, 6-, 8-, 12-, and 16-inch nominal diameter PVC pipe or 4-, 6-, 8-, 12-, 16-inch nominal diameter ductile iron pipe at various depths;
13. Furnishing and installing 2-inch PVC fittings when necessary at various depths;
14. Furnishing and installing on all PVC pipe and fittings, a continuous double-run of 12-gauge CCS tracer wire attached to the top of the pipe with duct tape. The wire shall be looped around each bell. There shall be no dead ends, and the locator wire shall be brought into tracer wire boxes installed within a valve box's concrete pad, in an isolated concrete pad (if no valve present), or in asphalt without a concrete pad. Tracer wire for direct bury installations shall be approved insulated copper clad steel (CCS) wire such as Copperhead High Strength Tracer Wire or Pro-Trace HF-CCS PE45 Tracer Wire. Wire splices must be with wire connectors suitable for buried service, and be corrosion and moisture-proof, such as DBR Kit by 3M, Snakebite by Copperhead Industries or equal;
15. Cleaning up and removing excess water main pipe and appurtenances;
16. Pressure testing the water main pipe;

17. Furnishing and installing temporary pipe shorts, valves and bends for full port flushing;
18. Furnishing and installing valve location protection devices per Standard Detail 3.05 whenever needed to keep valve locations visible;
19. Disinfecting the water main pipe and bacteriological testing;
20. Furnish and apply paint for any above ground or aerial crossing pipe and appurtenances. Paint to be high-grade enamel, OSHA blue for potable water or purple for reclaim water as directed by the Engineer;
21. Backfilling and compacting the trench;
22. Cleaning up and restoring the job site which shall include re-grading the terrain; and
23. Removing and legally disposing all waste materials.
24. Furnishing and installing 10-gauge tracer wire on ductile iron water mains 16" diameter and larger. Wire shall be double-strand, with the ends of each wire terminating in tracer wire boxes, per Detail 3.02.

Cover over pipe shall be defined as the vertical distance from the top of the pipe to the surface grade above the main. Trench depth shall be defined as the vertical distance from the bottom of the barrel of the pipe to the surface grade above the main.

Payment for connecting new water mains to existing water mains will be made utilizing the contract unit price for installing the fittings, polywrap, or valves used in the connection.

The cost to hydrostatically test and disinfect the ductile iron or PVC water mains shall be prorated and included in the pipeline construction unit prices. The prorated cost should include, but may not be limited to furnishing and installing all:

- 1) Material;
- 2) Labor;
- 3) Necessary pumps;
- 4) Recorder charts;
- 5) Gages (300PSIG limit, oil filled);
- 6) Chemicals;
- 7) Temporary valves;
- 8) Temporary plugs;
- 9) Sample taps, (including installation of brass dry main plugs after tap removal);
- 10) Blow off assemblies (including removal after disinfection is complete);
- 11) Dry main plugs.

necessary to pressure test and disinfect various sizes and depths of ductile iron pipe or PVC pipe. Furthermore, no extra compensation shall be paid to the Contractor for:

1. Furnishing and installing brass, dry main plugs at the locations of all removed sample taps, or
2. Removing existing "end of line" or blow-off valves after the pipeline has been disinfected and prior to connecting the newly installed pipeline to the existing water main.

All temporary materials or materials not remaining in the ground after the completion of the disinfection and pressure testing shall remain the property of the Contractor.

The pipe quantities to be paid for under this section shall be based on the size and the horizontal distance

in linear feet of ductile iron pipe, PVC pipe, or steel casing pipe measured along the top centerline of the pipe in place complete and acceptable to the Engineer.

Payment shall be made under:

| <u>Item No.</u> | <u>Description</u> | <u>Unit</u> |
|-----------------|--|-------------|
| 2100 | Furnish and install 4" ductile iron pipe | LF |
| 2102 | Furnish and install 6" ductile iron pipe | LF |
| 2104 | Furnish and install 8" ductile iron pipe | LF |
| 2105 | Furnish and install 10" ductile iron pipe | LF |
| 2106 | Furnish and install 12" ductile iron pipe | LF |
| 2108 | Furnish and install 16" ductile iron pipe | LF |
| 2149 | Furnish and install 2" PVC pipe and fittings at various depths | LF |
| 2150 | Furnish and install 4" PVC pipe | LF |
| 2152 | Furnish and install 6" PVC pipe | LF |
| 2154 | Furnish and install 8" PVC pipe | LF |
| 2156 | Furnish and install 12" PVC pipe | LF |
| 2158 | Furnish and install 16" PVC pipe | LF |

C2.20 Furnish and Install HDPE Pipe by Horizontal Directional Drilling

The Contractor shall provide all labor, equipment, and materials to furnish and install the HDPE pipe using horizontal directional drilling (HDD) as a work method. The furnishing and installation of the HDPE pipe shall include, but may not be limited to:

1. Furnish and install construction layout by a registered professional land surveyor;
2. Field locating all utilities, except existing water lines not shown properly on the plans, to confirm horizontal and vertical location in areas of possible conflict;
3. Excavating the access pits;
4. Maintaining the pits which shall include dewatering and sheeting and bracing as required by OSHA or as directed by the Engineer;
5. Joining HDPE pipe sections by butt fusion;
6. Pigging, cleaning or flushing the line to remove dirt, debris if directed by the engineer;
7. Furnishing and installing temporary valve, pipe shorts and bends to accomplish full port flushing of mains;
8. Furnishing and installing Department approved pipe and any pipe shorts as part of the pipeline;
9. Furnishing and installing 4-, 6-, and 8-inch nominal diameter HDPE pipe and 2-inch HDPE tubing at various depths by horizontal directional drilling;
10. Furnishing and installing on all HDPE pipe/tubing two continuous 10-gauge wires along the top of the pipe. There shall be no dead ends, and each locator wire shall be brought into tracer wire boxes installed within a valve box's concrete pad, in an isolated concrete pad (if no valve present), or in asphalt without a concrete pad. Connections between wire ends shall be made using an approved connection as shown in the standard details;
11. Tracer wire for directional drill installations shall be approved insulated copper clad steel (CCS) wire such as Copperhead SoloShot Extra HS or Pro-Trace HD-CCS PE45. For directional drilled HDPE pipe, a 1" conduit may be pulled back with the locating wires to ease installation and to prevent the wires from breaking. Wire splices made must be with wire connectors suitable for

buried service and be corrosion and moisture-proof, such as DBR Kit by 3M, Snakebite by Copperhead Industries or equal;

12. Removing ancillary water main pipe and/or appurtenances;
13. Pressure testing the water main pipe;
14. Disinfecting the water main pipe;
14. Backfilling and compacting the trenches or pits including re-grading the terrain;
15. Cleaning up and restoring the job site which shall include re-grading the terrain; and
16. Removing and legally disposing of all waste materials.

Cover over pipe shall be defined as the vertical distance from the top of the pipe to the surface grade above the main. Trench depth shall be defined as the vertical distance from the bottom of the barrel of the pipe to the surface grade above the main.

Payment for connecting new water mains to existing water mains will be made utilizing the contract unit price for installing the tapping sleeves, restraints, fittings or valves used in the connection.

The cost to hydrostatically test and disinfect the water mains shall be prorated and included in the pipeline construction unit prices. The prorated cost should include, but may not be limited to furnishing and installing all:

- 1) Material
- 2) Labor
- 3) Necessary pumps
- 4) Recorder charts
- 5) Gages (200 PSIG limit, oil filled)
- 6) Chemicals
- 7) Temporary valves
- 8) Temporary plugs
- 9) Sample Taps, (including furnishing and installation of brass dry main plugs in corporation saddles after sample tap removal)
- 10) Blow off assemblies (including removal after disinfection is complete)
- 11) Dry main plugs installed in the corporation saddles.

necessary to pressure test and disinfect various sizes and depths of HDPE pipe. Furthermore, no extra compensation shall be paid to the Contractor for:

1. Furnishing and installing brass, dry main plugs in HDPE electrofusion corporation saddles at the locations of all removed sample taps, or
2. Removing existing "end of line" or blow off valves after the pipeline has been disinfected and prior to connecting the newly installed pipeline to the existing water main.

All temporary materials or materials not remaining in the ground after the completion of the disinfection and pressure testing shall remain the property of the Contractor.

The pipe quantities to be paid for under this section shall be based on the size and the horizontal distance in linear feet of HDPE pipe measured along the top centerline of the pipe in place complete and acceptable to the Engineer.

Payment shall be made under:

| <u>Item No.</u> | <u>Description</u> | <u>Unit</u> |
|-----------------|---|-------------|
| 2200 | Furnish & install 2" HDPE tubing w/HDPE transition adapters at various depths | LF |
| 2201 | Furnish & install 4" HDPE pipe at various depths | LF |
| 2202 | Furnish & install 6" HDPE pipe at various depths | LF |
| 2203 | Furnish & install 8" HDPE pipe at various depths | LF |

C2.30 Temporary Service Lines

The Contractor shall provide all labor, equipment and materials necessary to furnish, install and remove temporary 2-inch service lines, connect the existing meters to the temporary service lines, and remove and dispose of all waste materials. The cost to reconnect the meters to the new mains will be paid under the appropriate meter set item.

Work shall include but may not be limited to:

1. Making all necessary excavations;
2. If necessary, burying the pipe to prevent a tripping hazard or securing the pipe to prevent damage during construction;
3. Making necessary taps to existing main or service line;
4. Making all necessary taps (2 may be required) that are required to affect the tie-in connection;
5. Furnishing and installing all necessary materials required to make the tie-in connections;
6. Furnishing and installing 2-inch high density polyethylene (HDPE) tubing; and
7. Furnishing and installing cap(s) or plug(s) and restraints adequate to withstand a working pressure of 150 psi, on all in-service open end(s) of pipe;
8. Furnishing all labor equipment and materials to remove the temporary service when no longer needed;
9. Backfilling, compacting, and re-grading the terrain;
10. Cleaning up and restoring the job site which shall include re-grading the terrain; and
11. Removing and legally disposing of all waste materials.

| <u>Item No.</u> | <u>Description</u> | <u>Unit</u> |
|-----------------|--|-------------|
| 2300 | Furnish, install and remove 2-inch temporary service lines | LF |

C2.40 Casing Installation

The Contractor shall provide all labor, equipment and materials to furnish and install steel casing pipe. The installation of steel casing pipe shall include, but may not be limited to:

1. Excavating the jacking and recovery pits;
2. Maintaining the jacking and recovery pits that shall include dewatering and sheeting and bracing where required or as directed by the Engineer;
3. Dewatering the roadway;
4. Furnishing, cutting and full depth welding the steel casing pipe;
5. Jacking the steel casing pipe;

6. Furnishing and installing the pipe "casing spacers" on the carrier pipe;
7. Furnishing and installing bulkheads inside the casing pipe ends to seal the inner space;
8. Backfilling and compaction of jacking and recovery pits;
9. Cleaning up and restoring the job site which shall include re-grading the terrain; and
10. Removing and legally disposing all waste materials.

Compensation for installing the carrier pipe in the casing pipe will be made under the appropriate pipeline construction pay item. The Engineer can exercise his authority and elect to have the Contractor install only the casing pipe, thereby waiving installation requirements for the carrier pipe.

Payment shall be made under: (no items)

| <u>Item No.</u> | <u>Description</u> | <u>Unit</u> |
|-----------------|--------------------|-------------|
|-----------------|--------------------|-------------|

C2.50 Removal and Abandonment of Pipe

The Contractor shall provide all labor, equipment and materials to remove the abandoned pipeline and appurtenances (such as valves, fittings, and other materials) as designated on the plans or directed by the Engineer.

The removal of the abandoned pipe shall include, but may not be limited to:

1. Furnishing all equipment, labor, tools and equipment to excavate the trench;
2. Maintaining the trench;
3. Removing the abandoned pipeline and appurtenances;
4. Furnishing and installing a restrained cap to plug any abandoned open-end pipe;
5. Furnishing and installing a cap or plug and restrain adequately to withstand a working pressure of 150 psi, on all pipe ends remaining in service;
6. Transporting the removed pipe and appurtenances, without delay, to a location designated by the Engineer;
7. Unloading the removed pipeline and appurtenances at the designated location;
8. Cutting of any existing pipe to accommodate abandonment;
9. Backfill and compacting the trench;
10. Cleaning up and restoring the job site which shall include re-grading the terrain; and
11. Removing and legally disposing of all waste materials.

Payment shall be made based on the size and horizontal distance in linear feet of pipeline removed measured along the top centerline. At the Department's option, all abandoned pipe and appurtenances shall remain the property of the Department. If the Department opts not to remain owner of the removed facilities, then the Contractor shall remove and properly dispose of the facilities at his expense.

Payment shall be made under:

| <u>Item No.</u> | <u>Description</u> | <u>Unit</u> |
|-----------------|---|-------------|
| 2500 | Remove 3" and smaller diameter abandoned pipe | LF |

2501 Remove 4" - 12" diameter abandoned pipe LF

C2.60 Cutting and Plugging

The Contractor shall provide all labor, equipment and materials to cut and plug 16-inch and smaller pipe as designed on the plans or as directed by the Engineer. To cut and plug pipe shall include, but may not be limited to:

1. Excavating and maintaining the trench;
2. Performing a minimum of two complete cuts of the pipe to facilitate the plugging.
3. Removing of pipe or appurtenances to allow for the installation of plugs on 8" or less open ends of pipe;
4. Furnishing and installing grout to plug any abandoned open end(s) pipe;
5. Furnishing and installing cap(s) or plug(s) and restraints to adequately withstand a working pressure of 150 psi, on all in-service open end(s) of pipe;
6. Backfill and compacting the trench;
7. Cleaning up and restoring the job site which shall include re-grading the terrain; and
8. Removing and legally disposing of all waste materials.

Payment shall be made for each cut and plug accomplished and accepted by the Engineer.

Payment shall be made under:

| <u>Item No.</u> | <u>Description</u> | |
|-----------------|---|----|
| 2600 | Cut and Plug 3-in. and smaller pipe, to include meter service lines | EA |
| 2601 | Cut and Plug 4-, 6- and 8-in. Pipe | EA |
| 2602 | Cut and Plug 10-, 12-, and 16-in. Pipe | EA |

C2.80 Incidental Tapped Connections

The Contractor shall provide all labor, equipment and material to connect existing 3-inch and smaller water mains to the newly installed water mains (see Standard Detail 5.06). The incidental tapped connections shall include, but may not be limited to:

1. All necessary excavations;
2. Maintaining the excavation which shall include dewatering, bracing and sheeting where required or as directed by the Engineer;
3. Making a minimum of two cuts into the existing pipe to facilitate the connection to the existing pipe;
4. Making all necessary taps (2 may be required) that are required to affect the tie-in connection;
5. Furnishing and installing all necessary material, including reducers and increasers approved by the Water Department, which is/are required to construct the tie-in connections;
6. Furnishing and installing a 2-inch gate valve and box close to the larger main;
7. Furnishing and installing 2-inch high density polyethylene (HDPE) tubing;
8. Furnishing and installing cap(s) or plug(s) and restraints adequate to withstand a working pressure of 150 psi, on all in-service open end(s) of pipe;
9. Backfill and compacting the trench;

10. Cleaning up and restoring the job site which shall include re-grading the terrain; and
11. Removing and legally disposing of all waste materials.

Payment shall be made for each 3-inch and smaller tapped connection furnished and installed into the piping system complete and working to the satisfaction of the Engineer. Payment for 2-inch gate valve and box will be made under the appropriate pay item number.

Payment shall be made under:

| <u>Item No.</u> | <u>Description</u> | <u>Unit</u> |
|-----------------|---|-------------|
| 2800 | Furnish and install 3" and smaller tapped connection (0-15' long) | EA |
| 2801 | Furnish and install 3" and smaller tapped connection (15' and longer) | EA |

C3.00 Thrust Restraint

The Contractor shall provide for all labor, equipment and materials to completely furnish and/or install thrust restraint. The furnishing and installation of the thrust restraint shall include but not be limited to:

1. Excavating the trench;
2. Maintaining the trench that shall include dewatering and bracing and sheeting where required or as directed by the Engineer;
3. Furnishing and installing approved wedge action restraint fitting or flange joint restraint;
4. Furnishing and installing manufactured restrained joints;
5. Furnishing of approved push-on restraint EPDM rubber gasket-type restraining devices (gaskets with stainless steel locking segments vulcanized into the rubber) on new push-on ductile iron pipe;
6. Furnishing and installing approved restraining devices on proposed PVC push-on joint pipe;
7. Furnishing and installing approved restraining devices on joints of existing pipe;
8. Backfill and compacting the trench;
9. Cleaning up and restoring the job site which shall include re-grading the terrain; and
10. Removing and legally disposing of all waste materials.

Payment for installation of manufactured restrained joints shall be for each bell and spigot joint assembled.

No additional compensation shall be made to the Contractor for field poured concrete in excess of the amount detailed in the Technical Specification or Standard Details without approval by the Engineer.

Payment will not be credited for restraining devices installed in conjunction with fire hydrant installations. Payment for installation of thrust restraints for fire hydrants (and for pipe on fire hydrant leads) shall be included in the price quoted for installation of fire hydrant assemblies.

Payment shall be made under:

| <u>Item No.</u> | <u>Description</u> | <u>Unit</u> |
|-----------------|--|-------------|
| 3000 | Furnish & install 4" wedge-action MJ or FL restraint | EA |
| 3001 | Furnish & install 6" wedge-action MJ or FL restraint | EA |

| | | |
|------|---|----|
| 3002 | Furnish & install 8" wedge-action MJ or FL restraint | EA |
| 3003 | Furnish & install 10" wedge-action MJ or FL restraint | EA |
| 3004 | Furnish & install 12" wedge-action MJ or FL restraint | EA |
| 3005 | Furnish & install 14" wedge-action MJ or FL restraint | EA |
| 3006 | Furnish & install 16" wedge-action MJ or FL restraint | EA |
| 3040 | Furnish & install 4" bell or MJ restraint on existing pipe | EA |
| 3041 | Furnish & install 6" bell or MJ restraint on existing pipe | EA |
| 3042 | Furnish & install 8" bell or MJ restraint on existing pipe | EA |
| 3043 | Furnish & install 10" bell or MJ restraint on existing pipe | EA |
| 3044 | Furnish & install 12" bell or MJ restraint on existing pipe | EA |
| 3045 | Furnish & install 16" bell or MJ restraint on existing pipe | EA |
| 3050 | Furnish & install 4" wedge-action MJ restraint on new PVC pipe | EA |
| 3051 | Furnish & install 6" wedge-action MJ restraint on new PVC pipe | EA |
| 3052 | Furnish & install 8" wedge-action MJ restraint on new PVC pipe | EA |
| 3053 | Furnish & install 12" wedge-action MJ restraint on new PVC pipe | EA |
| 3054 | Furnish & install 16" wedge-action MJ restraint on new PVC pipe | EA |
| 3070 | Furnish 4-inch push-on-joint gasket-type (gripper) restraint | EA |
| 3071 | Furnish 6-inch push-on-joint gasket-type (gripper) restraint | EA |
| 3072 | Furnish 8-inch push-on-joint gasket-type (gripper) restraint | EA |
| 3073 | Furnish 12-inch push-on-joint gasket-type (gripper) restraint | EA |
| 3074 | Furnish 16-inch push-on-joint gasket-type (gripper) restraint | EA |

C4.00 Fittings

The Contractor shall provide all labor and equipment to completely install plugs, caps, bends, sleeves, reducers, tees, crosses, and offsets. The installation of ductile iron fittings shall include, but not be limited to:

1. Excavating the trench;
2. Maintaining the trench which shall include dewatering and bracing and sheeting where required or as directed by the Engineer;
3. Furnishing and installing the appropriate fitting;
4. For HDPE pipe, furnishing and installing the appropriate HDPE mechanical joint adapters and back-up rings or mechanical joint glands, or SS inserts (if approved by the Engineer);
5. Backfill and compacting the trench;
6. Cleaning up and restoring the job site which shall include re-grading the terrain; and
7. Removing and legally disposing of all waste materials.

Additional compensation shall not be made for restraining devices used in conjunction with hydrant installations. Payment will be made for the number of each size and type of fittings installed and incorporated into the piping system complete, working, and operating to the satisfaction of the Engineer.

Payment shall be made under:

| <u>Item No.</u> | <u>Description</u> | <u>Unit</u> |
|-----------------|--|-------------|
| 4000 | Furnish and install 4" DI MJ plug or cap | EA |
| 4001 | Furnish and install 4" DI MJ bend, sleeve or reducer | EA |

| | | |
|--------|--|----|
| 4002 | Furnish and install 4" DI MJ tee | EA |
| 4003 | Furnish and install 4" (x 12") DI MJ offset | EA |
| 4004 | Furnish and install 6" DI MJ plug or cap | EA |
| 4005 | Furnish and install 6" DI MJ bend, sleeve or reducer | EA |
| 4006 | Furnish and install 6" DI MJ tee | EA |
| 4007 | Furnish and install 6" (x 12") DI MJ offset | EA |
| 4008 | Furnish and install 8" DI MJ plug or cap | EA |
| 4009 | Furnish and install 8" DI MJ bend, sleeve or reducer | EA |
| 4010.1 | Furnish and install 8" x 4" DI MJ tee | EA |
| 4010.2 | Furnish and install 8" x 6" DI MJ tee | EA |
| 4010.3 | Furnish and install 8" x 8" DI MJ tee | EA |
| 4011 | Furnish and install 8" (x 12") DI MJ offset | EA |
| 4012 | Furnish and install 12" DI MJ plug or cap | EA |
| 4013 | Furnish and install 12" DI MJ reducer | EA |
| 4013.1 | Furnish and install 12" DI MJ 11.25° (or 22.5°) bend or sleeve | EA |
| 4013.2 | Furnish and install 12" DI MJ 45° bend | EA |
| 4013.3 | Furnish and install 12" DI MJ 90° bend | EA |
| 4014.1 | Furnish and install 12" x 4" (or 6") DI MJ tee | EA |
| 4014.2 | Furnish and install 12" x 8" DI MJ tee | EA |
| 4014.3 | Furnish and install 12" x 12" DI MJ tee | EA |
| 4015 | Furnish and install 12" (x 12") DI MJ offset | EA |
| 4016 | Furnish and install 16" DI MJ plug or cap | EA |
| 4017 | Furnish and install 16" DI MJ reducer | EA |
| 4017.1 | Furnish and install 16" DI MJ 11.25° bend or sleeve | EA |
| 4017.2 | Furnish and install 16" DI MJ 22.5° bend | EA |
| 4017.3 | Furnish and install 16" DI MJ 45° bend | EA |
| 4017.4 | Furnish and install 16" DI MJ 90° bend | EA |
| 4018.1 | Furnish and install 16" x 4" (or 6") DI MJ tee | EA |
| 4018.2 | Furnish and install 16" x 8" DI MJ tee | EA |
| 4018.3 | Furnish and install 16" x 12" DI MJ tee | EA |
| 4018.4 | Furnish and install 16" x 16" DI MJ tee | EA |
| 4019 | Furnish and install 16" (x 12") DI MJ offset | EA |

C5.00 Fire Hydrants

The Contractor shall provide all labor, equipment and specified materials to completely furnish and/or install full and complete fire hydrant assembly on existing water main, or relocate existing fire hydrant assembly, as shown on the construction plans or as directed by the Engineer.

As notified in Specific Provision S4.02, each fire hydrant installation (replacement, relocation, or new isolated installation) issued for construction **must be completed within 10 calendar days** of issuance to the Contractor.

The standard fire hydrant assembly (FHA) to be furnished includes up to 10 lf of 6-in. DIP, hydrant elbow, hydrant barrel extension, and hydrant barrel as shown in Standard Detail 4.01. The standard "full" hydrant assembly to be furnished further includes a hydrant valve and a tee or tapping sleeve. When agreed by the Engineer, a Gradelok offset fitting may be used to adjust hydrant elevation, and will be compensated for separately.

(Note that whenever a Gradelok fitting is used with a fire hydrant installation, the standard 3 ft. to 5 ft. depth of bury required at the hydrant must be maintained.)

Hydrant assembly installation work order work shall include, but may not be limited to:

1. Excavation of hydrant assembly trench;
2. Maintaining the trench that shall include dewatering, bracing and sheeting where required or as directed by the Engineer;
3. As directed, installation either by:
 - a) cutting an existing hydrant tee out of an existing water main to remove and replace the tee, valve and hydrant assembly, or
 - b) removing existing hydrant assembly and/or valve for relocation or replacement, or
 - c) removing hydrant lead and hydrant assembly (downstream of existing hydrant valve) to facilitate hydrant relocation, or new valve and hydrant assembly installation
 - d) Tapping an existing main for a new fire hydrant installation;
4. Anchoring the hydrant to existing or new main;
5. Furnish and install up to and including ten (10) foot of 6-inch ductile iron pipe;
6. Remove any plugs, caps, restraining devices, etc. from existing water mains to facilitate the connection;
7. Furnish and install any and all mechanical thrust restraint required downstream of the hydrant valve in accordance with the Technical Specifications or as directed by the Engineer;
8. Furnish and install polyethylene encasement for all buried pipe and fittings;
9. Furnish and install hydrant in the plumb position, with 4.5 ft. clearance in the back and 7 ft. clearance in the front and on each side, from walls, poles and obstructions;
10. Furnish and install a concrete thrust collar around the barrel of the hydrant and 12 in. below grade as shown in Standard Detail 4.01;
11. Furnish and install a concrete "support block" under each hydrant;
12. Furnish and install a concrete support cradle under each hydrant tee on PVC mains;
13. Backfill and compact hydrant assembly trench;
14. Furnish high grade enamel OSHA yellow paint and paint hydrant barrel as required in the Technical Specifications;
15. Furnish high grade enamel OSHA green paint and paint the hydrant bonnet;
16. Furnish and install one blue, reflective pavement marker (RPM) in the street adjacent to the hydrant at a location to be determined by the Engineer. The RPM shall meet or exceed all provisions of the Florida Department of Transportation, Standard Specifications for Road and Bridge Construction, Section 706;
17. Furnish and install an approved blue VALVE curb marker on the adjacent curb (or edge of pavement if no curb is present, for each valve installed;
18. Pressure test the hydrant assembly in conformance with these documents;
19. Backfill and compact the trench;
20. Cleaning up and restoring the job site which shall include re-grading the terrain; and
21. Removing and legally disposing of all waste materials.

The Contractor shall do all things necessary to completely install a fire hydrant assembly in accordance with the Technical Specifications, Standard Details or as directed by the Engineer.

Additional compensation will be provided for any Maintenance of Traffic (MOT) devices required to complete a given work order, via either:

- 1) the MOT sub-contractor's invoice for that work (corroborated by count records the Contractor shall provide to the Engineer daily), plus 10% OH&P; or
- 2) if installations are self-performed by the Contractor, MOT will be paid at 7% of the work order sub-total.

Restoration required shall be compensated in accordance with the restoration contract pay items.

In addition, it will be the Contractor's responsibility to determine the correct size (bury depth) of each hydrant installed so that the requirements of the Technical Specifications are satisfied. Any hydrant not installed to the proper grade shall be replaced with one of the correct size by the Contractor at his expense prior to final approval and acceptance

Fittings required because of contractor convenience, (i.e. installed because the contractor elected to install a shallow bury hydrant) shall be furnished and installed at the contractor's expense.

Payment will be based on the number of hydrant assemblies installed complete and working to the satisfaction of the Engineer. Payment for Tees, Valves, Taps, Fittings (except the hydrant elbow which is part of the hydrant assembly), and Restoration will be made utilizing the appropriate contract pay items. Separate payment will be made for any 6-inch ductile iron pipe in excess of 10-feet required to connect the hydrant gate valve to the hydrant.

Payment shall be made under:

| <u>Item No.</u> | <u>Description (see C5.00, 3rd paragraph for definition of FHA & Full FHA)</u> | <u>Unit</u> |
|-----------------|---|-------------|
| 5000 | F&I Full FHA on new or ex. main – via Tee or Tap <i>(valve and tee/tap paid separate)</i> | EA |
| 5010 | F&I 6" Gradelok fitting | EA |
| 5011 | F&I 12" Gradelok fitting | EA |
| 5012 | F&I 24" Gradelok fitting | EA |

5.10 Fire Hydrants: Removal Only

The Contractor shall provide all labor, equipment, and material for work orders directing removal and salvage of existing fire hydrant assemblies from existing water mains. Hydrant removal and salvage includes, but may not be limited to:

1. Excavate the hydrant pit;
2. Furnish and install restraining devices to anchor the existing hydrant shut-off valve to the pipeline tee;
3. Remove hydrant from hydrant lead (or, remove hydrant and lead);
4. Furnish & install restrained plug or cap, and/or thrust block (if required and agreed by the Engineer) behind the cap or plug; or,
5. Furnish & install new spool-piece of appropriate diameter pipe, sleeve & restraints to restore the main line after Tee is removed;
6. Remove any hydrant protection post(s);
7. Backfill and compact the hydrant pit;

8. Clean up and restore the job site which shall include re-grading the terrain;
9. Remove and legally dispose of all waste materials;
10. Transport removed hydrant without delay to the location designated by the Engineer or legally dispose the hydrant; and
11. Unload the removed hydrant at the designated location.

Contractor shall be paid for each hydrant removed, salvaged, returned or disposed. All hydrants removed shall remain the property of the City unless otherwise directed by the Engineer. If the City opts not to remain the owner, the Contractor shall remove and properly dispose of the hydrant at his expense.

Costs of the fittings and thrust block (if required) shall be included in the unit price quoted for the removal pay item.

The Contractor shall receive additional compensation for the new pipe spool-piece, solid sleeve, and restraint devices required to restore the mainline, in accordance with the applicable contract pay item unit prices.

Compensation will be provided for any Maintenance of Traffic (MOT) devices required to complete a given work order, via either:

- 1) the MOT sub-contractor's invoice for that work (corroborated by count records the Contractor shall provide to the Engineer daily), plus 10% OH&P; or
- 2) if installations are self-performed by the Contractor, MOT will be paid at 7% of the work order sub-total.

Restoration required shall be compensated in accordance with the restoration contract pay items.

Payment shall be made under:

| <u>Item No.</u> | <u>Description</u> | <u>Unit</u> |
|-----------------|----------------------------|-------------|
| 5101 | Remove and salvage hydrant | EA |

C5.30 Protection Post

The Contractor shall provide all labor, equipment, and material for furnishing and installing protection posts as part of the hydrant, meter or fire line installation as shown on the plans or as directed by the Engineer. Hydrant protection post installation shall include, but may not be limited to, the following:

1. Excavation of protection post pit;
2. Furnishing and installing of 6-in. diameter ductile iron protection post in a plumb position with all of the hose nozzles clear of the posts;
3. Furnishing and installing the necessary concrete as called for in the Technical Specifications;
4. Furnishing OSHA yellow paint and painting protection post
5. Cleaning up and restoring the job site which shall include re-grading the terrain; and
6. Removing and legally disposing of all waste materials.

Payment shall be for each protection post that is installed and accepted by the Engineer.

Payment shall be made under:

| <u>Item No.</u> | <u>Description</u> | <u>Unit</u> |
|-----------------|-------------------------------------|-------------|
| 5300 | Furnish and install protection post | EA |

C6.00 Valves

The Contractor shall provide all labor, equipment and materials to completely furnish and install 2-inch through 16-inch gate valves, and 16-inch butterfly valves, including all accessories and incidentals.

Valve installation shall include, but may not be limited to:

1. Excavate the trench for installation and/or removal;
2. If existing valve located in vault, remove and dispose of the concrete lid/cover of a below-grade masonry vault, and remove top row of masonry blocks;
3. Maintaining the trench shall include dewatering and bracing and sheeting where required or as directed by the Engineer;
4. If valve replacement, remove and dispose of existing valve;
5. Furnish and install a specified valve onto an existing mainline with a valve box, including making two cuts of the existing pipe to remove the broken valve or to install the new valve;
6. Furnish and install a valve in a mainline with a valve box or a tapping valve on a tapping sleeve with a valve box;
7. Furnish and install an appropriately sized solid-sleeve, up to 4-ft. spool piece of pipe, and restraint devices necessary to install the valve or replacement, or (if not replacing a valve) to sleeve the pipe back together;
8. Polywrap all buried DIP and fittings installed;
9. Backfilling and compacting the trench or the vault;
10. Furnishing, forming and pouring a 6-inch thick concrete pad around each valve box installed in non-paved areas;
11. Furnishing paint and painting valve box cover;
12. Furnishing and installing or forming and pouring concrete support blocks under valves installed on PVC and HDPE pipeline;
13. Furnishing and installing valve curb markers and brass ID tags for each valve installed;
14. Cleaning up and restoring the job site which shall include re-grading the terrain; and
15. Removing and legally disposing of all waste materials.

Payment shall be made for the number of each size valve and valve box installed and incorporated into the piping system complete, working and operating to the satisfaction of the Engineer. Separate compensation shall be provided for MJ restraints, and any valve nut extension required, installed and accepted by the Engineer, per length of extension installed.

Payment shall be made under:

| <u>Item No.</u> | <u>Description</u> | <u>Unit</u> |
|-----------------|--------------------|-------------|
|-----------------|--------------------|-------------|

| | | |
|------|---|----|
| 6000 | F&I 2" gate valve and box | EA |
| 6001 | F&I 4" gate or tapping valve and box | EA |
| 6002 | F&I 6" gate or tapping valve and box | EA |
| 6003 | F&I 8" gate or tapping valve and box | EA |
| 6004 | F&I 10" gate or tapping valve and box | EA |
| 6005 | F&I 12" gate or tapping valve and box | EA |
| 6006 | F&I 16" gate or tapping valve (wow) and box on new main | EA |
| 6020 | F&I 16" butterfly valve (wow) and box on new main | EA |
| 6080 | F&I valve nut extension | EA |

C6.20 Line Stops

The Contractor shall furnish all labor, equipment, tools and materials to install line stops on existing water mains.

The line stop installation shall include but is not limited to:

1. Excavating the trench;
2. Maintaining the trench that shall include dewatering and bracing and sheeting where required or as directed by the Engineer;
3. Furnishing and installing the line stop;
4. Furnishing and installing polywrap on line stop appurtenances remaining on the pipe after the line stop is removed;
5. Furnishing and installing reverse dead-man restraint with split wedge action restraints as shown in Standard Detail 2.12A, as applicable, or pouring concrete encasement around the sleeve as directed by the Engineer;
6. Compacting soil in trench around dead-man and line stop to a minimum 98% modified proctor density;
7. Excavating the trench to remove line stop;
8. Backfilling and compacting the trench;
9. Cleaning up and restoring the job site which shall include re-grading the terrain; and
10. Removing and legally disposing of all waste materials.

Payment shall be made under:

| <u>Item No.</u> | <u>Description</u> | <u>Unit</u> |
|-----------------|---|-------------|
| 6200 | F&I 2" or 2-1/2" Line Stop on Existing Water Main | EA |
| 6201 | F&I 4" Line Stop on Water Main | EA |
| 6203 | F&I 6" Line Stop on Water Main | EA |
| 6205 | F&I 8" Line Stop on Water Main | EA |
| 6207 | F&I 10" Line Stop on Water Main | EA |
| 6208 | F&I 12" Line Stop on Water Main | EA |
| 6209 | F&I 16" Line Stop on Water Main | EA |
| 6210 | F&I 24" Line Stop on Water Main | EA |
| 6211 | F&I 30" Line Stop on Water Main | EA |
| 6212 | F&I 36" Line Stop on Water Main | EA |

Thrust restraint required for linestop installation shall be paid for under the appropriate contract pay items, i.e., split wedge-action restraints and forming, placing, and pouring reinforced concrete for deadmen, or forming, placing, and pouring reinforced concrete for concrete encasement. Restoration for linestop installations shall be paid for under the appropriate restoration contract pay item.

C6.30 Insertion Valves

The Contractor shall furnish all labor, equipment, tools and materials to install TEAM insertion valves on existing water mains that are under pressure

Insertion valve installation shall include but is not limited to:

1. Excavating the trench;
2. Maintaining the trench that shall include dewater and bracing and sheeting where required or as directed by the Engineer;
3. Cleaning the pipe;
4. Furnishing and installing the appropriate insertion valve;
5. Furnishing and installing polywrap on valve and pipe;
6. Backfilling and compacting the trench;
7. Cleaning up and restoring the job site which shall include re-grading the terrain; and
8. Removing and legally disposing of all waste materials.

Payment shall be made under: (no items)

C7.00 Taps

The Contractor shall provide all labor and equipment for installing tapping sleeves and making the appropriate **full port** tap complete and operable. The tapping sleeve installation shall include:

1. Excavating the trench;
2. Maintaining the trench that shall include dewatering and bracing and sheeting where required or as directed by the Engineer;
3. Furnishing and installing the tapping sleeve;
4. Pressure testing the tapping sleeve and valve;
5. Making the full port tap, up to and including 36-inch;
6. Furnishing and installing mechanical joint tapping sleeves for size on size pipe taps or as directed by the engineer;
7. Furnishing, installing and sealing the tapping sleeve with blue polyethylene encasement of not less than 8 mils thick;
8. Backfilling and compacting the trench;
9. Cleaning up and restoring the job site which shall include re-grading the terrain; and
10. Removing and legally disposing of all waste materials.

Payment shall be based on the number and size of tapping sleeves installed and incorporated into the piping system complete, working and operating to the satisfaction of the Engineer. Valves and valve boxes shall be paid for by the appropriate pay item.

Payment shall be made under:

| <u>Item No.</u> | <u>Description</u> | <u>Unit</u> |
|-----------------|--|-------------|
| 7001.0 | F&I 4" x 4" MJ tapping sleeve and make tap | EA |
| 7001.1 | F&I 6" x 4" Steel tapping sleeve and make tap | EA |
| 7001.2 | F&I 6" x 6" MJ tapping sleeve and make tap | EA |
| 7002.1 | F&I 8" x 4" Steel tapping sleeve and make tap | EA |
| 7002.2 | F&I 8" x 6" Steel tapping sleeve and make tap | EA |
| 7002.3 | F&I 8" x 8" MJ tapping sleeve and make tap | EA |
| 7003.1 | F&I 12" x 4" Steel tapping sleeve and make tap | EA |
| 7003.2 | F&I 12" x 6" Steel tapping sleeve and make tap | EA |
| 7003.3 | F&I 12" x 8" Steel tapping sleeve and make tap | EA |
| 7003.4 | F&I 12" x 12" MJ tapping sleeve and make tap | EA |
| 7004.1 | F&I 16" x ($\leq 8"$) MJ tapping sleeve and make tap | EA |
| 7004.2 | F&I 16" x 12" Steel tapping sleeve and make tap | EA |
| 7004.3 | F&I 16" x 16" MJ tapping sleeve and make tap | EA |

C8.00 Water Meter and Fire Line Service Installation

C8.10 Metered Services (Two-Inch and Less) with Pipe Work

The Contractor shall provide all labor, materials and equipment for the installation and/or transfer of ¾" (single or dual service), 1", 1½", and 2" meters, and 2" double detector check valves, as specified.

New meter service installations and/or transfers issued to the Contractor through work orders will be independent of pipeline construction projects – typically issued in response to customer applications for water service. Most will be isolated single installations, in varied locations across the City of Tampa water service area, which extends from South Tampa to New Tampa, from 50th Street to Memorial Highway.

As notified in Specific Provision S4.02, each new meter service installation issued through a work order **must be completed within fourteen (14) calendar days** of issuance to the Contractor.

Based on Department performance expectations from the Mayor, meter installations must be completed within 2 weeks of work order issuance **at least 98% of the time**.

Given the time constraints for these installations, the Contractor should expect some nighttime and/or weekend work will be required to complete meter installations issued through work orders – and that should be factored into unit prices quoted for these installations. Additional compensation for working non-standard hours or days will not be provided for meter service installation work orders. Unit prices quoted shall include all costs required to complete the services requested, as specified.

Meter service lengths (as described in the pay items) are defined as follows:

- 0-15' service line required from main to meter is up to 15' long
- +15-80' service line required is greater than 15', up to and including 80'
- +80-150' service line required is greater than 80', up to and including 150'

All water meters and double detector check valve assemblies will be furnished by the City, for installation

by the Contractor.

Meter service installation shall include, but may not be limited to:

1. Excavating and maintaining the trench;
2. Making the appropriate size tap;
3. When directed by the Engineer or as indicated in the standard details, furnish and install an appropriately sized steel, PVC or HDPE sleeve under paved areas for long-side meter service by open cut, horizontal directional drilling/directional bore or "moling", as directed by the Engineer or as indicated in the standard details. If steel is provided for sleeves it shall be SCH 40 pipe, PVC shall be SCH 80 solvent weld pipe, HDPE pipe shall be as specified elsewhere in the Contract per pipe size, i.e., 2" HDPE shall meet the HDPE tubing specification, 4" and above HDPE shall meet the HDPE pipe specification;
4. Furnish and install the appropriate size and type of corporation stop, HDPE tubing, PVC pipe, any required service fittings, curb stop, meter box and lid, and tail piece extension as designated by the Department's Technical Specifications and Standard Details;
5. For all long-side HDPE service lines, furnish and install two continuous 12-gauge wires along the top of the pipe, inside the sleeve. If a steel casing sleeve is used, tracer wire shall be taped every 12-inches to the top outside of the sleeve. There shall be no dead ends and each locator wire shall be routed from the corporation to the meter box. Connections between wire ends shall be made using approved connections at each end as shown in the standard details;
6. Installation of the appropriately sized (City furnished) meter, or transferring an existing meter to the new service line;
7. Relocating existing meters and/or adjusting existing meter boxes to grade;
8. Backfilling and compacting of all excavations;
9. Clean-up and return the job site to its original condition which includes but is not limited to restoring the elevation of surface to its original grade;
10. Removing and legally disposing of all waste materials.

Payment shall be made for each meter service furnished and installed and accepted by the Engineer.

Additional compensation will be provided for any Maintenance of Traffic (MOT) devices required to complete a given work order, via either:

- 1) the MOT sub-contractor's invoice for that work (corroborated by count records the Contractor shall provide to the Engineer daily), plus 10% OH&P; or
- 2) if installations are self-performed by the Contractor, MOT will be paid at 7% of the work order sub-total.

Additional compensation shall be provided for restoration in accordance with the contract restoration pay items.

Payment shall be made under:

| <u>Item No.</u> | <u>Description for Services</u> | <u>Unit</u> |
|-----------------|---------------------------------|-------------|
|-----------------|---------------------------------|-------------|

| | | |
|------|--|----|
| 8100 | Furnish, tap, & install 3/4" or 1" meter service (0-15') | EA |
| 8101 | Furnish, tap, & install 3/4" meter service (+15-80') | EA |
| 8102 | Furnish, tap, & install 3/4" meter service (+80-150') | EA |
| 8103 | Furnish, tap, & install 3/4" or 1" Dual meter service (0-15') | EA |
| 8104 | Furnish, tap, & install 3/4" Dual or 1" Dual meter service (+15-80') | EA |
| 8105 | Furnish, tap, & install 3/4" Dual meter service (+80-150') | EA |
| 8106 | Furnish, tap, & install 1" Dual meter service (+80-150') | EA |
| 8107 | Furnish, tap, & install 1" or 1-1/2" meter service (+15-80') | EA |
| 8108 | Furnish, tap, & install 1" or 1-1/2" meter service (+80-150') | EA |
| 8109 | Furnish, tap, & install 1 1/2" or 2" meter service (0-15') | EA |
| 8110 | Furnish, tap, & install 2" DDCV & service (0-15') | EA |

C8.30 Service Installations 3-inch and Larger

The Contractor shall provide for all the labor, equipment and materials for installing 3-inch and larger meters and/or installing double detector check valve assemblies (DDCVA) into a large service. The large service installation may be located in an above-ground vault, a below-ground vault, or may be an above-ground installation in accordance with the construction plans or as directed by the Engineer. The large service installation shall include, but is not limited to:

1. Obtaining from the Tampa Water Department, 26th Avenue Warehouse, a large meter assembly and/or double detector check valve assembly as directed by the Engineer or as shown the plans;
2. Installing a City-furnished double detector check valve assembly including the detector check bypass metered assembly;
3. Excavating and maintaining the trench;
4. Installing the furnished, large meter including furnishing and installing a 2-inch meter by-pass assembly and the-furnished by-pass meter; and
5. Furnishing and installing bolts, nuts, gaskets and all appurtenances necessary to install either the large meter or double detector check valve assembly;
6. Backfilling and compacting the trench;
7. Cleaning up and restoring the job site which shall include re-grading the terrain; and
8. Removing and legally disposing of all waste materials.

The Department shall provide the appropriate size meter and by-pass meter for all large meter services or appropriate size double detector check valve assembly. The Contractor shall furnish and install all bolts, nuts, gaskets, by-pass piping (large meter only) and appurtenances necessary to install a large meter or double detector check valve assembly.

Payment will be made for each large meter service installed or double detector check valve assembly installed and accepted by the Engineer.

Additional compensation will be provided for any Maintenance of Traffic (MOT) devices required to complete a given work order, via either:

- 1) the MOT sub-contractor's invoice for that work (corroborated by count records the Contractor shall provide to the Engineer daily), plus 10% OH&P; or

- 2) if installations are self-performed by the Contractor, MOT will be paid at 7% of the work order sub-total.

Additional compensation shall be provided for restoration required, in accordance with the contract restoration pay items.

Payment shall be made under:

| <u>Item No.</u> | <u>Description</u> | <u>Unit</u> |
|-----------------|--|-------------|
| 8300 | Install city-provided 3" meter (slab or vault to be paid separate) | EA |
| 8301 | Install city-provided 4" meter (slab or vault to be paid separate) | EA |
| 8302 | Install city-provided 6" meter (slab or vault to be paid separate) | EA |
| 8303 | Install city-provided 8" meter (slab or vault to be paid separate) | EA |
| 8320 | Install 4" double detector check valve assembly | EA |
| 8321 | Install 6" double detector check valve assembly | EA |
| 8322 | Install 8" double detector check valve assembly | EA |
| 8323 | Install 10" double detector check valve assembly | EA |
| 8324 | Install 12" double detector check valve assembly | EA |

C8.40 Vaults and Auxiliary Above-Ground Installation Materials

The Contractor shall provide for all labor, equipment, and materials for furnishing and installing an above-ground vault or below-ground vault and all auxiliary materials for an above-ground large service.

The vault and auxiliary materials shall include, but may not be limited to:

1. Excavating the trench;
2. Maintaining the excavations that shall include dewatering, sheeting and bracing where required or as directed by the Engineer;
3. Furnishing, installing, and constructing an above-ground vault per Standard Details 6.09 and 6.10 or below-ground vault incorporating one or more large service installation within the construction, per Standard Details 6.04 – 6.08;
4. Furnishing and installing a 6-inch concrete slab, reinforcing steel and pipe supports incorporating one or more free-standing above-ground large services within the construction, per Standard Details 6.01 - 6.03;
5. Backfilling and compacting the excavation;
6. Furnishing paint and painting the above-ground large service installation and;
7. Sealing top of vault to sides of vault with an approved material;
8. Cleaning up and restoring the job site which shall include re-grading the terrain; and
9. Removing and legally disposing of all waste materials.

The Contractor shall furnish and install the appropriate size pre-cast traffic bearing vault top and bottom slabs to construct a large service vault. If the Engineer determines that either part or all of any vault or other structure requires pouring concrete in-place (including reinforcing steel), then the Contractor shall pour a slab at no additional cost to the City.

The Contractor shall furnish all other material to complete construction of a large service vault.

Vaults shall be of various sizes. Payment shall be made for each vault installed and accepted by the Engineer.

Each above-ground assembly installed and accepted by the Engineer will be paid at the applicable line item. The pay item for furnishing and installing auxiliary materials shall include but not necessarily be limited to painting all above-ground facilities, furnishing and installing all required flanged bolt sets, furnishing and installing pipe supports for large meters and/or DDCVs and furnishing and installing the concrete pad as shown in the details.

Payment shall be made under:

| <u>Item No.</u> | <u>Description</u> | <u>Unit</u> |
|-----------------|---|-------------|
| 8404 | Furnish and install auxiliary materials for above-ground large service w/ 12' x 5' concrete slab | EA |
| 8405 | Furnish and install auxiliary materials for above-ground large service w/ 12' x 9' concrete slab | EA |

C9.00 Restoration and Miscellaneous Incidental Items

C9.10 General

Restoration services will be required through this Contract for Roadway and Roadside. These services will include both restoration work required incidental to Work Orders performed by the Contractor, and restoration work performed in response to a City-issued Work Order to restore areas (roadway or roadside) disturbed by other contractor(s) (others) performing water construction work for the City.

The Contractor shall furnish all labor, equipment, and materials to restore construction areas (to include streets, curbs, sidewalks, and driveways) to an equal or better condition than surfaces adjacent to the disturbed areas, and in conformance with the appropriate agency having jurisdiction over the restored area. Restoration services provided shall be in accordance with Contract Document's Technical Specifications Section T4.00 RESTORATION.

The Contractor shall restore areas to those limits as directed in the work order or by the Engineer and shall be compensated in conformance with the appropriate restoration contract pay items, for actual quantities furnished and installed or measured.

As stated herein, upon final payment by the Department, the Contractor shall maintain the surface of the unpaved trenches, shrubbery, trees, fences, sod, and other surfaces disturbed for a period of 6 months thereafter, and shall maintain the repaved areas, curbs, gutters, and sidewalks, if replaced by the Contractor, for one year after final acceptance of the respective item. The cost of maintaining the restored areas shall be incidental to the cost of restoring the areas disturbed by the Contractor. These costs shall be prorated and included in the cost for the respective contract pay item.

C9.20 Pavement - Roadway

The Contractor shall provide all labor, equipment and materials to remove and restore pavement and

pavement bases that were cut and removed during the course of construction. Pavement and pavement base restoration shall include roadways, driveways, parking lots, etc. Under this section, payment shall be made for:

1. Furnishing, placing, grading, and compacting approved lime rock base course;
2. Furnishing, placing, grading, and compacting approved crushed concrete base course;
3. Furnish and placing approved flowable fill;
4. Furnishing, placing, grading and compacting approved Superpave Type SP-12.5 asphalt concrete – Base or Surface Course;
5. Furnishing, placing, grading and compacting asphalt patch with approved Superpave Type SP-12.5 or Type SP-9.5;
6. Restoring 6" thick concrete driveway;
7. Furnishing and installing brick pavement;
8. Installing brick pavement;
9. Furnishing and installing Thermoplastic Striping;
10. Furnishing, placing, grading and compacting Superpave Type SP-9.5 asphaltic concrete Overlay;
11. Mechanical milling of 1-inch of existing asphalt including proper disposal of the milled material;
12. Mobilization required for mechanical milling operations;
13. Furnishing and installing traffic loops as specified and directed by the Engineer;
1. 15 Furnishing and installing signalization loops as specified and directed by the Engineer;
16. Furnishing Traffic Control Officer (Off-Duty Law Enforcement);
17. Furnishing and installing work zone signs;
18. Furnishing and installing traffic control devices to right-of-way permit requirements;
19. Removing, transporting and disposing of pavement, concrete curb, asphaltic curb and other items removed during construction;
20. Cleaning up and restoring the job site which shall include re-grading the terrain; and
21. Removing and legally disposing of all waste materials;
22. Prepare and provide site specific traffic control plans that have been signed-and-sealed by a licensed Florida Professional Engineer when required for MOT, in accordance with the applicable ROW-owning agency's requirements.

All surface restoration shall be as directed by the Engineer or the regulatory agency having jurisdiction over the roadway. All areas requiring pavement restoration shall be saw cut prior to construction pavement removal. The costs to mechanically saw cut pavement joints are considered incidental to pavement restoration and should be included in the cost.

Asphalt shall be measured for payment based on the number of SY-IN for patches with a surface area less than 8 square yards or larger areas with less than one and a half tons installed. Asphalt shall be measured based on tonnage for larger areas requiring greater than 1.5 tons of asphalt furnished and installed. Pavement, concrete curb, asphaltic concrete curb or other items removed during the course of pipeline construction shall be disposed of by the Contractor in a manner satisfactory to the Department. The cost of removal and disposal associated with all items shall be included in the assigned restoration item.

When required and authorized by the City based on project conditions, flowable fill may be utilized for bedding and backfilling utility trenches and paving subbase as an alternative to installing compacted granular fill. Flowable fill mix and installation shall conform to FDOT Standard Specifications for Road and Bridge Construction (2014), Section 121-1 through 121-6. Mix design must be approved by the City prior to jobsite delivery.

City street pavement shall be in accordance with of Tampa’s PAVEMENT/RIGHT OF WAY RESTORATION REQUIREMENTS – REV-2012 guidelines - see contract Technical Specification Section T4.07.

Bricks shall be replaced in accordance with the of Tampa’s PAVEMENT/RIGHT OF WAY RESTORATION REQUIREMENTS – REV-2012 guidelines. See Technical Specification Section T4.07.

Mobilization shall only be paid for milling operations and shall only be paid once per job site unless otherwise approved in advance by the Engineer. Milling shall be made in thickness increments of one inch and shall include proper disposal of the milled material.

The Contractor shall furnish all labor, materials and equipment, necessary to replace and maintain complete traffic signalization loops as specified and directed by the Engineer. The work includes all saw-cutting of pavement, placement of loop wires and lead-in cables, non-metallic wire hold downs, wire identification tags and sealants, splicing and termination strips, testing and all other work incidental to the installation of a signalization loop complete in place. All signalization loops shall conform to the requirements of the latest edition of the Florida Department of Transportation Standard Specifications for Road and Bridge Construction. Payment for traffic signalization loops will be made at the appropriate contract item unit price per signalization loop installed.

The Contractor shall be compensated for any thermoplastic striping required based on the striping sub-contractor’s invoice for work done for a given work order, plus 10% OH&P, or by the applicable contract pay items.

The Contractor shall be compensated for Maintenance of Traffic (MOT) installations required to complete a given order, based on the MOT sub-contractor’s invoice for the work order (corroborated by count records the Contractor shall provide to the Engineer daily) plus 10% OH&P, or if installations are self-performed by the Contractor, MOT will be paid at 7% of the work order sub-total.

When and if required for maintenance of traffic, the Contractor shall be compensated for signed-and-sealed MOT traffic control plans based on the Engineer’s invoice plus 10% OH&P.

Asphalt restoration quantities shall be paid per square-yard per inch or tonnage as applicable.

Payment shall be made under:

| <u>Item No.</u> | <u>Description</u> | <u>Unit</u> |
|-----------------|--|-------------|
| 9200 | Furnish, place, and compact lime rock base | CY |
| 9201 | Furnish, place, and compact crushed concrete base | CY |
| 9202 | Furnish and place approved flowable fill | CY |
| 9203 | Furnish, place, and compact asphalt patch (Superpave Type B-12.5 or Type B-9.5 w/ , 8 SY or < 1.5 Tons) | SY-IN |
| 9205 | Furnish and install asphalt concrete base or surface course Superpave Type SP-12.5 | TN |
| 9207 | Furnish, place and grade Superpave Type SP-9.5 asphaltic concrete overlay | TN |
| 9208 | Mobilization to perform milling operations | EA |
| 9209 | Mechanical milling of asphalt roadways in 1-inch increments | SY-IN |

| | | |
|------|---|----|
| 9210 | Furnish and install 6" thick concrete driveway | SY |
| 9211 | Restore brick pavement, including base material | SY |
| 9212 | Install brick pavement furnished by City, Contractor F&I base | SY |
| 9250 | Furnish and install signalization loops | EA |

C9.30 Roadside Restoration

The Contractor shall provide for all labor, equipment and materials to restore the roadside areas disturbed during the course of the pipeline construction. Under this section, payment shall be made for:

1. Restoring typical concrete curb and gutter including stabilization of sub-base and installation of curb pads;
2. Restoring stone or pre-cast curb;
3. Furnishing and placing asphaltic concrete curb;
4. Remove and restoring 4-inch thick concrete sidewalk, including applicable sidewalk ramps;
5. Restoring paver block sidewalk or driveways;
6. Restoring the roadside areas with approved sod. Restoring the roadside area and ditch bottoms and sides with sod shall include furnishing, grading, and placing the sod; and
7. Restoring the roadside areas with approved sprig and seed. Restoring the roadside area with sprig and seed shall include furnishing, grading, placing, fertilizing, mulching, sprigging and seeding.
8. Furnishing and installing detectable warning walking surfaces as directed by Engineer. The detectable warning surface will conform to the Florida Department of Transportation Standard Specifications for Road and Bridge Construction, current edition. The detectable warnings shall be installed in conformance with FDOT Standard Indexes 304 and 310 or in conformance with the requirements of the right-of-way regulatory agency with responsibility of the affected right-of-way. (Payment for curb and sidewalk associated with pedestrian access ramps will be made under the appropriate sidewalk and curb pay items.)
9. Cleaning up and restoring the job site which shall include re-grading the terrain; and
10. Removing and legally disposing of all waste materials.

Sidewalk and curb replacement pay quantities shall have maximum limits as specified in these documents, as shown in the plans or as directed by the Engineer. All linear foot units shall be measured along the curb line. In all cases, the sod or seed placed is to conform in kind to the existing at the particular location.

Permanent fence agreed to be removed or disturbed for water or stormwater main construction shall be replaced in-kind, to match existing, subsequent to construction. Fence restoration shall be coordinated with the property owner and the City and shall be to the satisfaction of the Engineer. Compensation for permanent fence restoration shall be based on the fencing sub-contractor's invoice plus 15% OH&P; or if restoration is executed by Contractor, in accordance with Specific Provision 4.05.

Payment shall be made under:

| <u>Item No.</u> | <u>Description</u> | <u>Unit</u> |
|-----------------|--|-------------|
| 9300 | Furnish and install Type "D" concrete curb | LF |
| 9301 | Furnish and install valley curb | LF |
| 9302 | Furnish and install Miami curb | LF |
| 9303 | Furnish and install Type "F" concrete curb | LF |

| | | |
|------|---|----|
| 9304 | Furnish and install stone or precast curb | LF |
| 9305 | Remove and install existing stone curb | LF |
| 9306 | Furnish and install asphaltic concrete curb | LF |
| 9307 | Furnish and install 4" thick concrete sidewalk | SY |
| 9308 | Furnish and install paver block sidewalk or driveway | SY |
| 9309 | Grade and sod roadside, ditch bottoms and sides - Bahia | SY |
| 9310 | Grade and sod roadside, ditch bottoms and sides – St. Augustine | SY |
| 9311 | Grade, fertilize, sprig, and hydro-seed roadside | SY |
| 9312 | Furnish and install detectable warnings on concrete sidewalk disability ramps | EA |

C9.40 Grouting Abandoned Pipe

The Contractor shall provide all labor and material necessary to grout abandoned pipes in place including but not limited to taps, caps, plugs, pipes, valves and fittings necessary to complete the work in a manner acceptable to the Engineer. Under this section, payment shall be made for:

1. Excavating the trench;
2. Maintain the trench;
3. Furnishing and installing the appropriate fittings necessary to inject and blow-off the grout in a manner acceptable to the Engineer;
4. Completely filling the designated pipe with an approved grout material;
5. Removing injection and blow-off pipes and fittings, and plugging tapped plugs and caps;
6. Removing excess concrete from the trench; and
7. Backfilling and compacting the trench.
8. Cleaning up and restoring the job site which shall include re-grading the terrain; and
9. Removing and legally disposing of all waste materials.

Restoration shall be paid separately under the appropriate pay item.

Payment shall be made under:

| <u>Item No.</u> | <u>Description</u> | <u>Unit</u> |
|-----------------|----------------------|-------------|
| 9400 | Grout abandoned pipe | CY |

C9.41 Miscellaneous Backfill

When authorized by the Engineer, the Contractor shall provide all labor, equipment and materials to place and compact replacement backfill soils picked-up from the Water Department Distribution Yard (or furnish, place, and compact Contractor-provided backfill soils) as required to: 1) complete Restoration Work Orders; or 2) to replace excavated backfill soils removed from the site by others; or 3) to backfill voids created whenever large service vaults or large meters are removed (per Contract Pay Items 9600 or 9601); or as otherwise authorized by the Engineer. Acceptable soils materials and installation shall be as specified in Technical Specifications section T2.04 Trenching, Backfilling and Compacting.

Payment for backfill provided shall be per compacted cubic yard. Contractor shall provide digital photographs of excavations to be backfilled, taken prior to fill placement, depicting measuring tools

(measuring tape for length and width, rod or stick for depth) clearly indicating the length, width and depth of the trench backfilled.

Payable limits for backfill shall exclude depth (thickness) of required base course and surface course – photos provided should clearly show these exclusions.

Payment shall be made under:

| <u>Item No.</u> | <u>Description</u> | <u>Unit</u> |
|-----------------|---|-------------|
| 9410 | Place and compact backfill soils | CY |
| 9411 | Furnish, place and compact backfill soils | CY |

C9.50 Incidentals

The Contractor shall provide all labor, equipment and material for reinforced concrete construction and repairs and repair of sanitary laterals hit but that were improperly marked (“improperly”, as defined in the SSOCOF “Damage Prevention Guide” and Chapter 556, F.S.). See Contract Documents Specific Provision Section S-20.01.

Reinforced concrete construction can include concrete pads, concrete vault walls, ditch pavement, headwalls, manholes, inlets, shocks pads, concrete "dead-man" restraints, etc.

For any pipeline construction work orders issued, if requested by the Engineer, the Contractor shall provide all labor, equipment and materials for professional quality video photography documentation of the preconstruction site condition along the proposed pipeline route.

Under this Section, payment shall be made for:

1. Furnishing, forming and placing min. 3,000 psi concrete with reinforcement as required;
2. Restoring sanitary sewer service lines (laterals) by furnishing and installing the necessary C-900, DR 18 green PVC pipe and flexible couplings, in accordance with City Wastewater Department requirements <Pay Item No. 9504>;
3. Furnishing professional quality video photography of pre-construction site conditions along proposed pipeline route as specified in these contract documents and as required.
4. Backfilling and compacting the excavation;
5. Cleaning up and restoring the job site which shall include re-grading the terrain; and
6. Removing and legally disposing of all waste materials.

Payment shall be made under:

| <u>Item No.</u> | <u>Description</u> | <u>Unit</u> |
|-----------------|--|-------------|
| 9500 | Furnish, form, place reinforced concrete | CY |
| 9504 | Replace damaged but not marked sanitary laterals, with PVC | LF |
| 9505 | Furnish video photography | LF |

C9.60 Removal and Demolition of Large Service Vaults and Concrete Slabs

The Contractor shall provide all labor, materials, equipment and incidentals required to demolish and remove existing large service vaults and/or concrete slabs as shown in the plans or as directed by the Engineer. "Large service" herein refers to vaults or slabs housing or supporting DDCVAs or larger than 3-in. meters, as shown in the appropriate applicable Water Department Standard Construction Details.

The removal and demolition of large service vaults and slabs shall include, but may not be limited to:

1. Excavating the trench;
2. Removing existing large service fittings, including but not limited to valves, check valves and meters;
3. Demolishing concrete vaults including, cutting and removal of top slabs and manholes, cutting and removal of exterior walls to the elevation described in the plans;
4. Demolishing and/or removal of vault bottoms;
5. Demolishing and/or removal of large service concrete slabs;
6. Backfilling and restoring demolished areas;
7. If designated by the Engineer, transporting removed large service fittings to a designated location;
8. Backfilling and compacting the excavation;
9. Cleaning-up and restoring the job site which shall include re-grading the terrain; and
10. Removing and legally disposing of all waste materials.

Pipe and fittings installed in place of the large service fittings removed shall be compensated per the appropriate contract pay items. Payment shall be made for each large service vault demolished and accepted by the Engineer. Payment for fill dirt required will be made under the Pay Items 9410 or 9411.

Payment shall be made under:

| <u>Item No.</u> | <u>Description</u> | <u>Unit</u> |
|-----------------|---|-------------|
| 9600 | Demolish and Remove large service vaults | EA |
| 9601 | Demolish and Remove large service concrete slab | EA |

C9.70 Muck Removal

The Contractor shall provide all labor, equipment and materials to remove and replace unsuitable or unstable trench materials with suitable materials. The removal and replacement of trench materials shall include, but may not be limited to:

1. Removing trench muck or other unsuitable materials encountered within the trench below the pipe invert elevation; and
2. Backfilling and compacting the excavation with acceptable backfill soils;
3. Cleaning up and restoring the job site which shall include re-grading the terrain; and
4. Removing and legally disposing of all waste materials.

Payment shall be made for each cubic yard of muck material excavated and removed, and replaced.

Payment shall be made under:

| <u>Item No.</u> | <u>Description</u> | <u>Unit</u> |
|-----------------|--------------------------------|-------------|
| 9701 | Excavation and removal of muck | CY |

C9.80 Tree Removal, Planting and Protection

The Contractor shall provide all labor, equipment, and materials to remove tree roots. The removal of a tree roots shall include but may not be limited to:

1. Removal of all roots inside the trench;
2. Removal of all roots outside the trench to 12 inches below finished grade;
3. Removing and legally disposing of all waste materials.

Tree diameter shall be determined by measuring the circumference of the trunk 4-½ feet above existing ground level.

Trees less than 5-inches in diameter will be considered as part of the normal trench excavation and will be prorated and included under the appropriate pipeline installation contract item.

Tree protection shall include, but may not be limited to:

1. Root pruning all tree roots along the tree-ward side of the trench with a clean vertical cut as shown on the plans or as indicated by the Engineer.
2. Furnishing and installing orange fencing for a 1-foot radius around grand oaks in areas where work is being done with heavy equipment;
3. Backfilling and compacting the excavation;
4. Cleaning up and restoring the job site which shall include re-grading the terrain; and
5. Removing and legally disposing of all waste materials.

Root pruning shall be performed in accordance with City standards and requirements, and to the satisfaction and approval of the Engineer.

Tree planting shall include, but may not be limited to:

1. Excavation of the tree pits;
2. Furnishing and installing the required number of 2-inch diameter Oak trees including replacing and compacting backfill, as indicated on the plans or as directed by the Engineer;
3. Furnishing and installing required fertilizer or chemical required for planting of trees;
4. Backfilling and compacting the excavation;
5. Cleaning up and restoring the job site which shall include re-grading the terrain; and
6. Removing and legally disposing of all waste materials.

Payment shall be made under:

| <u>Item No.</u> | <u>Description</u> | <u>Unit</u> |
|-----------------|--------------------|-------------|
| 9801 | Root prune | LF |

C9.90 Exploratory Pits

The Contractor shall provide all labor, materials and equipment to excavate exploratory pits at locations designated on the plans or as directed by the Engineer **for the sole purpose of locating existing water lines. This item shall not be used to locate utilities other than water lines.** Payment for the location of utilities other than water lines shall be included in other applicable pay items with no separate compensation.

Additional exploratory pits shall only be allowed, when agreed by the Engineer, to locate water main(s) in areas where uncertainty of pipe location is high, or where its location is (or might be) critical – based on other known utilities in the area. The excavation of the exploratory pits shall include, but may not be limited to:

1. Excavating the pits;
2. Maintaining the pits that include sheeting and bracing or dewatering as may be required or as directed by the Engineer;
3. Backfilling and compacting the excavation;
4. Cleaning up and restoring the job site which shall include re-grading the terrain; and
5. Removing and legally disposing of all waste materials.

All work shall be for exploratory pits of **various sizes and depths**. The excavating of exploratory pits shall be paid for per each pit excavated, refilled to original grade and accepted by the Engineer.

Compensation for exploratory pits shall be provided at a fixed rate of \$650.00 per agreed and accepted pit.

Payment shall be made under:

| <u>Item No.</u> | <u>Description</u> | <u>Unit</u> |
|-----------------|--------------------|-------------|
| 9900 | Exploratory Pits | EA |

C9.92 Miscellaneous Incidentals

The Contractor shall provide all labor, equipment and materials for the installation of blow-off assemblies.

The work shall include but is not limited to:

1. Furnishing and installing standard blow-off assembly (per Standard Detail 2.16: Blow-off Valve Assembly w/2” PVC or HDPE Pipe, and Detail 2.17: Blow-off Valve Assembly for ≥4” Mains) with the proper size cap or plug and restraint, a two-inch threaded tap, all brass, HDPE or PVC pipe and fittings necessary to adjust the blow-off assembly to proper grade;
2. Furnishing and installing 2” gate valve and valve box with concrete pad;
3. Furnishing and installing a #37 HDPE meter box in conformance with the Standard Detail 5.10;
4. Backfilling and compacting the excavation;
5. Cleaning up and restoring the job site which shall include re-grading the terrain; and
6. Removing and legally disposing of all waste materials.

Payment shall be made under:

| <u>Item No.</u> | <u>Description</u> | <u>Unit</u> |
|-----------------|--------------------|-------------|
|-----------------|--------------------|-------------|

| | | |
|------|---|----|
| 9920 | Furnish and install blow-off assembly w/valve and meter box per Detail 2.16 | EA |
| 9921 | Furnish and install blow-off assembly w/valve and meter box per Detail 2.17 | EA |

Additional compensation shall be allowed for the appropriate sized cap and restraint required for blow-offs installed per Detail 2.17, in accordance with the applicable Contract Pay Item.

C9.93 Concrete Block Thrust Restraint

The Contractor shall provide for all labor, equipment and materials to completely furnish and install concrete thrust restraint when authorized by the engineer. The installation of the concrete thrust restraint shall include but not be limited to:

1. Excavating the trench;
2. Maintaining the trench that shall include dewatering and bracing and sheeting where required or as directed by the Engineer;
3. Furnishing and installing approved pre-cast thrust blocks;
4. Furnishing, forming, and pouring thrust blocks;
5. Backfilling and compacting the excavation;
6. Cleaning up and restoring the job site which shall include re-grading the terrain; and
7. Removing and legally disposing of all waste materials.

No additional compensation shall be made to the Contractor for field poured concrete in excess of the amount detailed in the Technical Specification or Standard Details without prior approval by the Engineer.

Payment will not be credited for restraining devices installed in conjunction with fire hydrant installations. Installation of thrusting units for fire hydrants is to be included in the price quoted for installation of fire hydrant assemblies.

Payment shall be made under:

| <u>Item No.</u> | <u>Description</u> | <u>Unit</u> |
|-----------------|---|-------------|
| 9930 | Furnish and Install pre-cast thrust blocks | EA |
| 9931 | Furnish, form and pour concrete thrust blocks | CY |

C9.94 Asbestos Concrete Pipe

The Contractor shall provide all labor, equipment and materials to cut the pipeline and remove appurtenances (such as valves, fittings, and other materials) as designated in the plans or directed by the Engineer. The Contractor shall provide certification that he is properly licensed with all appropriate Federal, State and Local agencies to perform such work. Cutting asbestos concrete pipe shall include, but may not be limited to:

1. Cutting full circle asbestos concrete pipe with required safeguards against airborne asbestos particles (minimum of 2 cuts);
2. Removal and proper disposal of asbestos concrete pipe;
3. Abandonment of asbestos concrete pipe site, if appropriate;

4. Furnishing and installing grout or cap to plug open ends of buried pipe;
5. When applicable, connecting new pipe to existing asbestos concrete pipe, including furnishing and installing a maximum of two applicable transition couplings as needed to make the connections;
6. Backfilling and compacting the trench including re-grading the terrain;
7. Cleaning up and removing excess water main pipe and appurtenances; and
8. Removal and disposal of all waste materials.

Payment shall be made based on each complete cut into asbestos containing pipe, necessary to replace or remove the pipe. Transition couplings shall be paid for under appropriate fittings item. All appurtenances removed shall remain the property of the Tampa Water Department except the Asbestos Concrete Pipe that shall be the responsibility of the Contractor to provide for proper disposal or transport and disposal.

Payment shall be made under:

| <u>Item No.</u> | <u>Description</u> | <u>Unit</u> |
|-----------------|-------------------------------------|-------------|
| 9940 | Asbestos Concrete Pipe Complete Cut | EA |

C9.98 Contingency Allowance

The contingency allowance shall be used by the City of Tampa as directed by the Engineer. Payment shall be made as a lump sum to pay for furnishing and installing items required for construction but not listed in the Contract. Contractor shall provide an invoice listing the items and quantities along with the lump sum price. The Engineer may request a cost estimate for a contingency item from the Contractor prior to construction.

Payment shall be made under:

| <u>Item No.</u> | <u>Description</u> | <u>Unit</u> |
|-----------------|-----------------------|-------------|
| 9980 | Contingency Allowance | LS |

C9.99 Crew Day Allowance – NOT USED

C10.00 Payment and Performance Bond Allowance

The Payment and Performance Bond Allowance shall be paid to the Contractor as a lump sum reimbursement of the actual premium paid for the Bond. Contractor shall provide the payment performance bond as part of the contract agreement and will be reimbursed with the first work order. Reimbursement for the invoice cost of these bond(s) shall be made upon receipt of a certified copy of the invoice for the bond(s) from the Bonding Company to the Contractor.

Payment shall be made under:

| <u>Item No.</u> | <u>Description</u> | <u>Unit</u> |
|-----------------|--|-------------|
| 10000 | Payment and Performance Bond Allowance | LS |

C11.00 Maintenance of Traffic Allowance

The Maintenance of Traffic (MOT) Allowance shall be paid to the Contractor as a lump sum reimbursement on each Work Order using one, and only one of the following methods:

- 1) the MOT sub-contractor's invoice for that work (corroborated by count records the Contractor shall provide to the Engineer daily), plus 10% markup; or
- 2) if MOT installations are self-performed by the Contractor, MOT will be paid at 3% of the work order sub-total as calculated when the work associated with the Work Order has been completed.

Reimbursement for the invoice cost of the MOT shall be made upon receipt of a certified copy of the invoice from the MOT Company to the Contractor.

Payment shall be made under:

| <u>Item No.</u> | <u>Description</u> | <u>Unit</u> |
|-----------------|----------------------------------|-------------|
| 11000 | Maintenance of Traffic Allowance | LS |

WATER TECHNICAL AND MATERIAL SPECIFICATIONS

W-00 GENERAL REQUIREMENTS

All materials shall be in accordance with these Material Specifications and shall, in no event, be less than that necessary to conform to the requirements of any applicable law, ordinances and codes. All materials or products that will be in contact with potable water shall be listed by the National Science Foundation (NSF-61 listed) or by an approved certifying agency as conforming to the requirements of ANSI/NSF-61.

Materials provided for construction on or for the City's reclaimed water distribution system shall be in accordance with color coding specifications provided in the Florida Administrative Code (F.A.C.), Chapter 62-610. All piping, pipeline appurtenances (including valves and outlets) shall be color coded to differentiate reclaimed water from domestic or other water. Underground piping which is not manufactured of metal shall be color coded or marked for reclaimed water distribution systems using Pantone Purple 522C using light stable colorants - underground metal pipe shall be color coded using purple as a predominant color. Visible, above-ground portions of the reclaimed water distribution system shall be clearly color coded or marked. All reclaimed water valves shall be appropriately tagged or labeled (bearing the words in English and Spanish: "Do not drink" together with the equivalent standard international symbol) to warn the public and employees that the water is not intended for drinking.

Items designated to be "domestically manufactured" shall be manufactured, assembled, and tested in their entirety within the United States of America or its territories. Items designated to be "domestically assembled" may be foreign manufactured but shall be assembled and tested in their entirety within the United States of America or its territories. Items requiring a "domestic presence" may be foreign-manufactured and/or assembled and/or tested, but the manufacturer shall have a designated representative or agent located within the United States of America, and that representative or agent shall be available to provide on-site service if required by the City of Tampa Water Department (Department).

All materials shall be new, unused, and correctly designed. They shall be of standard first grade quality, produced by expert workmen, and intended for the use for which they are offered. Materials or equipment which, in the opinion of the Department, are inferior or are lower grade than indicated, specified, or required, shall not be accepted. All materials used in this contract must be approved in advance by the Engineer. In conformance with section G-4.02 of these contract documents, any two items of the same kind, type, or classification, and being used for identical types of service, shall be made by the same manufacturer. Unless approved in advance by the engineer, only one manufacturer may be used for each item under this contract.

W-10 DUCTILE IRON PIPE

1. GENERAL

Ductile iron pipe shall be domestically manufactured in accordance with the latest revision of ANSI/AWWA C-151/A21.51. Pipe shall be furnished in 18- or 20-foot laying lengths. Pipe shall be lined with a standard thickness cement mortar lining and seal coated in accordance with the latest revision of ANSI/AWWA C-104/A21.4 and NSF 61. Pipe outside coating shall be an asphaltic coating in accordance with ANSI/AWWA C-151/A21.51, latest revision. All pipe materials used in potable water systems shall comply with NSF Standard 61. Unrestrained joint pipe shall be either the rubber-ring compression-type push-on joint or mechanical joint.

2. PRODUCTS

a) Push-on Joint Pipe

- i) Push-on joint pipe shall be supplied with all joint accessories. Accessories shall include gaskets and lubricant in sufficient quantity for the proper assembly of each joint. Gaskets for push-on joints shall be made of ethylene propylene diene monomer (EPDM) rubber, except: Acrylonitrile butadiene (NBR) gaskets shall be used for potable water mains that are located in soil that is contaminated with low molecular-weight petroleum products or non-chlorinated organic solvents or non-aromatic organic solvents. Fluorocarbon (FKM) gaskets shall be used for potable water mains that are located in soil that is contaminated with aromatic hydrocarbons or chlorinated hydrocarbons. Fluorocarbon (FKM) gaskets shall be used for potable water mains if the soil is contaminated with aromatic hydrocarbons or chlorinated hydrocarbons, and is also contaminated with low molecular-weight petroleum products or organic solvents. All plain ends shall be painted with a circular stripe on the pipe barrel to allow a visual means of checking proper assembly.
- ii) All push-on joints shall be in accordance with ANSI/AWWA C-111/A21.11, latest revision.
- iii) Pressure Class shall be as follows:

| <u>Diameter</u> | <u>Min. Pressure Class</u> |
|-----------------|----------------------------|
| 4" to 16" | 350 |
| > 16" | 250 |

b) *Mechanical Joint Pipe*

- i) Mechanical joint pipe shall be supplied with all joint accessories. Accessories shall include lubricant, gaskets, ductile iron glands, bolts, and nuts, all in sufficient quantity for the assembly of each joint. The bolts and nuts shall be manufactured of high-strength, low-alloy steel such as "Corten", "Usalloy", or "Acipalloy". The follower gland shall be ductile iron. Gaskets for mechanical joints shall be made of ethylene propylene diene monomer (EPDM) rubber.
- ii) All mechanical joints shall be in accordance with ANSI/AWWA C-111/A21.11, latest revision.
- iii) Pressure Class shall be as follows:

| <u>Diameter</u> | <u>Min. Pressure Class</u> |
|-----------------|----------------------------|
| 4" - 16" | 350 |
| >16" | 250 |

c) *Flanged Flexible Joint Pipe*

- i) Flexible-joint pipe shall be push-on, ball-and-socket, freely deflecting, and restrained using a corrosion resistant locking device. Accessories shall include locking segments, rubber retainers, lubricant, and gaskets. Thickness class shall be as follows:

| <u>Diameter</u> | <u>Min. Thickness Class</u> |
|-----------------|-----------------------------|
| 6" | 54 |
| 8" | 55 |
| 12" | 56 |
| WM-2 | |

- ii) The joint shall be capable of a full 15° free deflection with no reduction in the waterway.

d) *Flanged Pipe*

- i) Flanged pipe shall conform to the requirements of AWWA C115, in nominal 18- or 20-foot lay lengths. The pipe shall be minimum Special Thickness Class 53 rated for a maximum working pressure of 250 psi.
- ii) Flanges shall be ductile iron and shall have long hubs. There shall be no leakage through the pipe threads, and the flanges shall be designed to prevent corrosion of the threads from outside.
- iii) Flanges shall meet the requirements of ASME B16.1, class 125 flanges. Flanges, flange facing, drilling, and protecting shall be as specified for flanged pipe. Bolts and nuts for flanged joints shall be Type 316 stainless steel unless otherwise stated on the Plans or directed by the Engineer.
- iv) Except where otherwise directed by the Engineer, gaskets for flanged joints shall be of the full-face type, meeting the requirements of ANSI B16.21. Gaskets shall be EPDM rubber.

e) *Manufactured Restrained Joint Pipe*

- i) Joints shall be push-on in accordance with ANSI/AWWA C-111/A21.11. Joints shall be secured by wedged locking shims or a follower gland which shoulder against a retaining ring permanently fastened to the spigot end of the pipe within the joint. Gaskets for manufactured restrained pipe joints shall be made of EPDM rubber.
- ii) Pressure Class shall be as follows:

| <u>Diameter</u> | <u>Min. Pressure Class</u> |
|-----------------|----------------------------|
| 4” -16” | 350 |
| >16” | 250 |

3. QUALITY CONTROL AND TESTING

- a) All pipe shall meet or exceed all hydrostatic, performance and acceptance tests as set forth in ANSI/AWWA C-151/A21.51, latest revision.
- b) Submittals shall include manufacturer drawings and brochures that clearly indicate size, dimensions, weights, pressure class or thickness class, performance standards, etc. If this documentation is omitted, the ductile iron pipe may be rejected at the sole option of the City.

4. MANUFACTURER

- a) Ductile iron pipe, unless specified below, shall be by U.S Pipe, American (aka American Cast Iron Pipe Company), McWane Cast Iron Pipe Company, Griffin Pipe Products Company, or approved equal.
- b) Flexible Joint pipe shall be “Flex-Lok Boltless Ball Joint Pipe” (American), “USI FLEX Boltless Flexible Joint Pipe” (U.S. Pipe), “Snap-Lok River Crossing Pipe” Griffin Pipe Products), or approved equal.

- c) Manufactured Restrained Joint pipe shall be “Flexring” (American), “TR-Flex” (U.S. Pipe), “Super-Lock” (20-in. & 24-in. pipe) and “Thrust-Lock” (30-in. & 36-in.) (McWane Cast Iron Pipe Company), “Snap-Lok” (Griffin Pipe Products), or approved equal.
- d) Ductile iron pipe shall be domestically manufactured in the United States.

W-11 HDPE (HIGH DENSITY POLYETHYLENE) PIPE

1. GENERAL

HDPE pipe shall be manufactured in accordance with the latest edition of AWWA C906. Pipe shall be furnished in 40-foot laying lengths.

2. PRODUCTS

- a) Pipe outside diameter shall be ductile iron pipe size.
- b) Standard dimension ratio shall be DR-11. Pressure class shall be 160 psi.
- c) All HDPE pipe, sizes 4-inch and larger, shall meet the requirements of AWWA Standard C 906-99 (or latest revision).
- d) The piping shall be permanently blue-coded to provide water main identification. When pipe is striped, stripes shall be blue, along the entire outside length of the pipe 90 or 120 degrees apart, and shall be made by co-extrusion or impregnation. Fully colored blue pipe co-extruded from permanently pigmented HDPE is also acceptable.
- e) All service taps on HDPE mains shall require a service saddle, manufactured specifically for HDPE pipe, equal to or better than Ford FS- or FC-202, or JCM 406. The cutting tool shall be a shell type for HDPE pipe (hole) cutter with internal teeth or double slots and be designed to accommodate AWWA C-906 pipe (twist drill bits and auger bits shall be prohibited). The saddles used should provide full support around the circumference of the pipe and provide a bearing area of sufficient width along the axis of the pipe (2” minimum), ensuring that the pipe will not be distorted when the saddle is tightened.
- f) Pipe shall have manufactured markings as following:
 - i) Nominal size and OD base
 - ii) Standard material code designation
 - iii) Dimension
 - iv) Pressure class
 - v) AWWA designation (AWWA C906-99)
 - vi) Material test category of pipe
 - vii) Manufacturer’s test code
- g) All HDPE pipe shall be installed with tracer wire, per the *Tracer Wire* specifications.
- h) Stainless steel inserts are required in HDPE pipe ends to facilitate connections to fittings or valves.

3. QUALITY CONTROL AND TESTING

- a) All pipe shall meet or exceed all hydrostatic performance and acceptance tests as set forth in AWWA C906, latest edition. Manufacturer shall furnish an affidavit that all materials delivered comply with standards set forth in these specifications.
- b) HDPE pipe shall be made of resin approved by the National Sanitation Foundation (NSF).
- c) All HDPE pipe shall meet the requirements of NSF Standard 61.
- d) All HDPE pipe shall be made of materials conforming to polyethylene code designation PE 4710, with a minimum cell classification of PE 454474 C or higher.

4. MANUFACTURER

HDPE Pipe provided shall be better than or equal to: CRS "PolyPipe", PE 4710;

Quail Piping, PE 4710; Performance Pipe "DriscoPlex 4000 Series", PE-4710, 4"- 12" diameter

W-12 HDPE TUBING

1. GENERAL

All water service lines two (2) inches in diameter and smaller shall be constructed of high-density polyethylene (HDPE) pressure tubing.

2. PRODUCT

- a) The standard dimension ratio (SDR) shall be 9 for CTS tubing sizes. The average outside diameter, minimum wall thickness and respective tolerances for any cross-section shall be as specified in ASTM D2737. The average inside diameter, minimum wall thickness, and respective tolerances for any cross-section shall be as specified in ASTM D2239.
- b) Polyethylene extrusion compound from which the PE tubing are extruded shall comply with the applicable requirements for the Type III, color and U.V. code E, Class C, PE 4710, very high molecular weight polyethylene plastic material manufactured in accordance with AWWA C-901, latest revision, as specified in ASTM D1248.
- c) HDPE pressure tubing shall have a color and ultraviolet code E and a minimum cell classification of PE 454474 E as specified in ASTM D3350.
- d) The polyethylene extrusion compound shall be of virgin quality approved for potable water service by the National Sanitation Foundation. The polyethylene extrusion compound shall be manufactured with sufficient and proper ultra-violet color stabilizers.
- e) Polyethylene tubing shall be blue and have U.V. color stabilizers so that the pipe is not affected in color or flexibility for a minimum of four (4) years.

3. QUALITY CONTROL AND TESTING

- a) Environmental stress cracking resistance testing shall be performed in accordance with ASTM D1693, Condition C, and shall have no failures after 5000 hours duration.

- b) When submitting for approval of HDPE not listed in Section 4, include manufacturer drawings and brochures that clearly indicate size, dimensions, weights, performance standards, etc. If this documentation is omitted, the HDPE may be rejected at the sole option of the City.

4. MANUFACTURER

All HDPE tubing shall be manufactured by Performance Pipes "DriscoPlex", Endot EndoPure", Vanguard "Bruiser", Charter Plastics "Blue Ice" or approved equal.

W-13 PVC (POLYVINYL CHLORIDE) PIPE

1. GENERAL

All PVC pressure pipe shall be manufactured in accordance with AWWA Standard C-900, latest revision

2. PRODUCT

- i) PVC pipe, 4" through 16", shall be DR-18 pressure class 235 with ductile iron pipe equivalent ODs. The pipe shall be approved by the National Sanitation Foundation for use as a potable water main. The pipe color shall be blue and the nominal laying length per pipe section shall be 20 ft. Shall be DR-18 pressure class 235 psi with ductile iron pipe equivalent ODs.
- ii) Joints shall be "push-on" and shall be made by joining pipe spigot end and integral wall-thickened bell end. All joints shall meet all requirements of ASTM Standard D3139. Each bell shall be an integral-wall section joint assembly using elastomeric-gasket seals. All gaskets shall meet all requirements for performance as specified by ASTM F-477. All integral joint gaskets shall be made of EDPM rubber. Each bell shall be an integral-wall section joint assembly using elastomeric-gasket seals.
- iii) When required for fitting and valve connection, restraints used shall be mechanical devices designed specifically for PVC pipe, per the Restraints specification.
- iv) All service taps on PVC mains shall require a service saddle, manufactured specifically for PVC pipe, equal to or better than Ford FS- or FC-202, or JCM 406. The cutting tool shall be a shell type for PVC pipe (hole) cutter with internal teeth or double slots and be designed to accommodate AWWA C-900 pipe (twist drill bits and auger bits shall be prohibited). The saddles used should provide full support around the circumference of the pipe and provide a bearing area of sufficient width along the axis of the pipe (2" minimum), ensuring that the pipe will not be distorted when the saddle is tightened.
- v) All PVC pipe shall be installed with tracer wire, per the Tracer Wire specifications.
- vi) Pipe shall be homogeneous throughout and be free of visible cracks, holes, foreign material, blisters, or other visible deleterious faults.

3. QUALITY CONTROL AND TESTING

- a) All pipe shall meet or exceed all hydrostatic, performance and acceptance tests as set forth in AWWA C-900, latest revision.
- b) If requested by the Engineer, prior to shipment of the pipe to the project site, the Contractor shall submit to the Engineer, test reports and certifications as described below duly certified by the manufacturer's testing facility or

an independent certified testing laboratory demonstrating full compliance with AWWA C-900. Certification from the supplier is not acceptable.

- c) If requested by the Engineer, notarized certificates of conformance shall be provided by the manufacturer that each lot of pipe has been manufactured, sampled, and tested per AWWA C-900. The City shall be provided in writing the means to cross-reference the markings with the certification and test reports (i.e. date of manufacturer, a lot number and shift number etc.) If this information is marked on the pipe in a code, the markings shall be decoded in writing.

4. MANUFACTURER

- a) All push-on joint (and unrestrained) C-900 PVC DR18 pipe shall be domestically manufactured and shall be equal to or better than: Vasallo C-900; Diamond Plastics C-900; North American Pipe Corporation C-900; or JM C-900 PVC pipe.
- b) Restrained joint PVC pipe shall be: JM Eagle "Eagle Loc 900", CertainTeed Certa-Lok C900/C905 RJ PVC, or approved equal.

W-20 VALVES

1. GENERAL

This section includes all valves to be owned and maintained by the City of Tampa Water Department. Requirements of this section apply to all valves unless exceptions are shown or stated on the plans or specific provisions.

Resilient Seat Gate Vales ("Valves") provided under this specification shall be suitable for installation on ductile iron or cast iron pipe, and C-900 PVC. Valves shall be manufactured in accordance with AWWA C-509 or AWWA C-515, latest editions, as applicable, and as specified herein.

Plug valves "valves" shall be of non-lubricating, eccentric type, shall meet or exceed the latest revision of AWWA Standard C517, and shall meet or exceed the requirements of this specification

2. PRODUCT

a) *Valve Boxes*

- i) Shall be designed to provide access to an underground valve's 2-inch operating nut at a depth of two-feet or greater. Valve boxes shall be suitable for installation in areas subject to heavy vehicle traffic loading.
- ii) Shall include removable valve box cover with "WATER" label as shown on the Standard Dimension Detail titled "Valve Box".
- iii) Shall be manufactured of Class 30 or 35 grey iron.
- iv) Shall consist of four parts: valve box cover, riser, top section, and bottom section.
- v) Shall be the same dimension, within manufacturing tolerances, as shown in Standard Dimension Detail "Valve Box".

b) *Gate Valves (4-inch and larger)*

- i) Gate valve operation
 - (1) Valves installed in public rights-of-way shall be right-hand (clockwise) open.
 - (2) Valves installed on the David L. Tippin Water Treatment Plant property (or at remote pumping locations) shall be left-hand (counter clockwise) open.
- ii) Valve installed below grade shall have mechanical joint ends. Valves installed above grade shall be flanged.
- iii) Mechanical joints and accessories shall be manufactured in accordance with AWWA Standards C-110 and C-111.
- iv) Mechanical joint bolts-and-nuts shall be manufactured of high-strength, low-alloy steel such as "Corten", "USalloy", or "ACIPalloy".
- v) Valves stems shall be non-rising and manufactured from stainless steel in accordance with AWWA C-509/C-515.
- vi) Stems, stem-nuts and wedges shall act independently. Stems shall be sealed by at least two O-ring seals, one located both above and below the thrust collar, and shall be replaceable with the valve full open and while subjected to full rated pressure. Stems shall be provided with low-friction torque-reducing thrust bearings located both above and below the stem collar. Thrust washers may be used to separate the thrust collar from iron surfaces.
- vii) Valve bodies and gates shall be cast iron or ductile iron manufactured in accordance with ASTM A126 or ASTM A536 respectively, and AWWA C-509 or AWWA C-515 as applicable.
- viii) All internal and external exposed ferrous surfaces of the valve body and gate shall have an epoxy coating applied to a minimum of eight mils, in accordance with AWWA C-550.
- ix) The wedge shall be bronze manufactured in accordance with ASTM B62. It shall be fully encapsulated with rubber molded in place and bonded in accordance with ASTM D429 A or B as specified in AWWA C-509/C-515. Mechanically attached seats will not be accepted.
- x) Hollow gates shall be provided with a drain in the bottom to flush the internal cavity of foreign material and stagnant water each time the valve is operated.
- xi) Gate valves provided under this specification shall be suitable for installation on ductile iron or cast iron pipe, and C-900 PVC.
- xii) Gate Valves shall have an EPDM Resilient seat.
- xiii) All bonnet bolts, gland bolts, nuts and other trim hardware exposed to the outside environment shall be stainless steel. Thrust collar tie-rod bolts shall be stainless steel.

c) *Tapping Valves*

(Note: Tapping Valve materials specifications shall be equivalent to those listed herein for Gate Valves, except as alternately specified below.)

- i) Tapping valves shall be resilient seat gate valves with one end mechanical joint, and one end flanged.

- ii) Tapping valve interior waterway shall be a full-opening and capable of passing a full-sized shell cutter through the valve.
- iii) Tapping valve shall be provided with a tapping-flange and flanged joint accessories.
- iv) Tapping-flange shall have a raised face or lip designed to engage a corresponding recess in a tapping sleeve as defined in MSS SP-60.
- v) Tapping-flanges shall conform to dimensions and drillings of ANSI B16.1, Class 125, ANSI/AWWA C110/A21.10.
- vi) All tapping valves shall be interchangeable with multiple makes of tapping sleeves.

d) *2-inch Gate Valves*

(Note: 2-inch Gate Valve materials specifications shall be equivalent to those listed herein for Gate Valves, except as alternately specified below.)

- i) 2" Gate Valves shall be resilient seat, have push-on or threaded ends, and be manufactured in accordance with AWWA C-509.
- ii) Valve Ends:
 - (1) Valve ends for push-on joint valves shall conform to AWWA C-111 and shall be suitable for use with iron pipe size plastic pipe as well as iron pipe.
 - (2) Valve ends for threaded joint valves shall have female iron pipe connections compatible with N.P.T. threads as specified in AWWA C-800.

e) *Plug Valves (16" and larger)*

- i) Valves shall be of the non-lubricated eccentric type and shall be furnished with end connections as shown on the plans. Flanges shall be per the ANSI B16.1 125 lb. standard. End-to-end length of flanged valves shall be per AWWA C517, Table 1. Mechanical joint ends shall be to the AWWA Standard C111-64. Mechanical joint gaskets shall be made of Ethylene Propylene Diene Monomer (EPDM) rubber. External nuts and bolts shall be 316 stainless steel (SS).
- ii) Body shall be of ASTM 536, Grade 65-45-12, ductile iron (DI). Port area shall be 100% of standard pipe area. Valve port area shall meet or exceed standard pipe area per ASME/ANSI B36.10M. The body shall have minimal pooling designed specifically with a flushing side port to provide complete flushing of the valve every time it cycles. Port of valve shall be rectangular and of one design throughout the entire size range.
- iii) Seats shall be rectangular ported, 1/8" thick welded overlay of not less than 95% pure nickel. Seat area shall be at least 1/2" wide and raised. The raised surface shall be completely covered with nickel to ensure that the plug face contacts only the nickel seat.
- iv) Plug shall be one-piece castings of ASTM 536, Grade 65-45-12; ductile iron. The plug shall have a cylindrical seating surface eccentrically offset from the center of the shaft. Plug shall not contact the seat until at least 90% closed. The interference between the plug face and body seat, with the plug in the closed

position, shall be externally adjustable in the field with the valve in the line under pressure. Plugs shall be faced with EPDM rubber. Spherical shaped plugs are not acceptable.

- v) Bearings shall be sleeve type and made of sintered, oil impregnated permanently lubricated type 316 SS ASTM A743, Grade CF8M, Welded-In nickel seat. Non-metallic bearings shall not be acceptable.
- vi) Packing shall be Polytetrafluoroethylene (PTFE) braided and multiple V-Ring with external adjustment, - 20 to 450 Degree F. Packing gland shall permit inspection, adjustment or complete replacement of packing without disturbing any part of the valve or actuator assembly, except the gland follower. Non-adjustable packing or packing requiring actuator removal to replace the packing is not acceptable.
- vii) Grit Excluders in the form of PTFE washers at the upper and lower journals shall be provided to prevent the entry of grit and foreign solids into the bearing areas.
- viii) Shaft Seals shall be multiple V-ring type with a packing gland follower. Shaft seals shall be externally adjustable and repackable under pressure without removing the actuator or bonnet from the valve. All Flanged and MJ plug valves shall have an air gap between shaft packing and bottom of actuator for visual inspection, adjustment or complete replacement of packing without disturbing any portion of the valve or actuator except the packing gland follower. This valve shaft packing design must have been used successfully within the county for the past 10 years. Valves utilizing O-ring seals or non-adjustable packing shall not be acceptable.
- ix) Pressure ratings shall be 150 psi to face of plug, tested per AWWA C504. Every valve shall be given a hydrostatic shell test and seat test, with test results being certified and to be provided upon request.
- x) Worm Gears shall be constructed in accordance AWWA C517 and shall be IP68 rated continuous duty to 50 ft. Test certificates, signed by chief engineer of gear operator manufacturer, must be supplied showing full compliance to AWWA C517.
 - (1) Actuator type shall be G Series for 16” and MG series for 18” or larger, buriable worm gear with 2 inch square nut operator.
 - (2) Worm gear operators shall be enclosed in a ductile iron housing with outboard seals to protect the bearings and other internal components. The actuator shaft and the quadrant shall be supported on permanently deep-groove ball bearings. Input shaft and fasteners shall be made of stainless steel. Gears shall be efficiency optimized 3 stage gear reduction type. Worm gear operators shall be sized at full bidirectional at 150 psi.
 - (3) Externally adjustable open and closed position stops shall be provided. The adjustable closed position stop shall be used to set closing torque and provide adjustment to compensate for change in pressure differential or flow direction. Gears shall incorporate the use of a Rotorlok Device for backwinding protection to prevent undesired reverse rotation of the gear train at the extents (i.e. fully closed position) of travel when holding a residual applied torque.
 - (4) Gears shall have a two-year warranty from date of shipment and shall have a metal tag containing a serial number, ratio; number of turns shall be riveted to the gear for future identification. Gears shall be Rotork Model IW-RL-MD-RAW.

- (5) Manual operators shall be provided with completely enclosed mounting brackets or adapters. The operators shall be equipped with adjustable stops to prevent over-travel in both the open and closed position with standard 2-inch square operating nuts with skirts as listed elsewhere herein, or with handwheel if for above ground service.
- (6) All plug valves shall open by turning the operating nut or handwheel clockwise (open-right). Orient operators with horizontal plug shafts such that the plug rotates upward upon opening.
- (7) Buried valves shall incorporate the use of an Aunspach Model D86 overtorg protector.
- (8) All operator components between the operating nut and the adjustable stops shall be designed to withstand, without damage, an input torque of 300 pound-foot (lbf. ft). The operator shall also be able to apply output torque required to operate the valve under adverse conditions without exceeding input torque as allowed under AWWA Standard C517.
- (9) Coating shall be 4-mils minimum Blue Epoxy Tnemec 141 (NSF Std. 61) on non-stainless steel interior/exterior surfaces. Interior/exterior standard surface prep (SP10) shall meet AWWA C550 standard.
- (10) Valves shall be NSF/ANSI 372 certified lead-free and NSF/ANSI 61 certified for drinking water.

f) *Insertion Valve (4" to 12")*

- i) be installed in live cast iron, ductile iron, C-900 PVC, and asbestos cement pipelines without requiring the shutdown of water flow through the pipe. The design should allow the insertion valve to be installed into an existing pressurized pipeline while maintain constant pressure and service. Insertion valves provided shall be true resilient seat gate valves that will remain in the water distribution piping system after insertion. Insertion valves must safely operate in balanced and unbalanced pressure situations- pressure equalization on the downstream (or upstream) side of the closed valve shall not be necessary to open the valve
- ii) be capable of pressure-tight assembly to the exterior of the pipe in which flow is to be stopped at a working pressure not to exceed 250 psi
- iii) have a valve body that provides full mechanical protection of the pipe, and that is permanently restrained to the pipe
- iv) have a ductile iron wedge, encapsulated with EPDM rubber
- v) have a triple O-ring seal stuffing box (2 upper and 1 lower O-rings)
- vi) have stainless steel fasteners and valve stem (min. 304SS)
- vii) operate at 250 psi maximum working pressure
- viii) have all gaskets and O-rings hat are to remain with the valve upon completion made of EPDM rubber

- ix) have a ¾” NPT test plug on the outlet throat of the sleeve for pressure testing the sealed sleeve at 150 psi prior to cutting the pipe
- x) extract the coupon from the cut pipeline.

have a ductile iron body, bonnet and wedge that provide strength and pressure ratings that meet or exceed the requirements of AWWA C-515 or C-509 Standards.

open right (clockwise).

be capable of working on Cast/Grey Iron or Ductile Iron Class A B C and D, IPS PVC, C900 and C909 PVC, Steel, AC pipe diameters without changing either top or bottom portion of split valve body.

be suitable for working pressures up to 250 psi. The pressure rating designation must be cast into the body of the insertion valve.

have stuffing box, operating stem, and resilient wedge that are removable, repairable, and/or replaceable under pressure.

have valve body that provides full mechanical protection of the pipe, and that is permanently restrained to the pipe.

have a body of two-piece ductile iron casting manufactured to specifications of ASTM A536, latest revision, min. Grade 65-45-12, with 8-mil (min.) epoxy coating inside and out that meets or exceeds ANSI\AWWA C-550 Standards, and is certified to ANSI\NSF 61.

have a ductile iron wedge, fully encapsulated with EPDM rubber by high pressure and high temperature compression or injection mold process. There shall be no exposed iron. EPDM rubber shall be ANSI\AWWA NSF-61 certified.

have a wedge that seats on the valve body and not on the pipe. The wedge shall be totally independent of the carrier pipe – it shall not come into contact with the carrier pipe or depend on the carrier pipe to create a seal.

have a wedge that rides inside the body channels to maintain wedge alignment throughout its travel control, regardless of high- or low-flow pressure or velocity.

the wedge shall be symmetrical and seal equally well with flow in either direction.

have gate valve stem and wedge nut made of copper alloy in accordance with Section 4.4.5.1 of AWWA Standard C-515.

have a 2” standard (square), NRS (non-rising stem) operating nut in accordance with ASTM A126, Class B.

have a NRS stem with integral thrust collar in accordance with Section 4.4.5.3 of AWWA Standard C-515. Two piece stem collars are not acceptable.

open and close through AWWA standard turns per inch.

have a triple O-ring stem seal with two O-rings located above and one O-ring located below the thrust collar.

have mechanical joint (MJ) ends for connection of the valve to the pipeline.

the stuffing box, operating stem and resilient wedge (complete bonnet and all moving parts) shall be removable, repairable and/or replaceable under pressure. So that, in the event the valve stem is broken or damaged, the bonnet can be removed under pressure.

All bolting materials shall meet or exceed the physical strength requirements of ASTM A307 with dimensions conforming to ANSI B18.2.1 (304 SS min.).

The sleeve shall be pressure tested prior to cutting the pipe, either through the use of the temporary knife gate installed on the valve body or through a blind flange installed on the valve body, to 150 psi.

The tapping cutter shall extract the coupon from the cut pipeline.

3. QUALITY CONTROL AND TESTING

a) *Valve Boxes*

- i) All valve boxes shall be manufactured of Class 35 grey iron

b) *Gate and Tapping Valves*

- i) The Gate Valve's resilient seat shall be bubble-tight against a 200-psi water working pressure and maintain zero leakage at all times.
- ii) The wedge shall be bronze manufactured in accordance with ASTM B62. It shall be fully encapsulated with rubber molded in place and bonded in accordance with ASTM D429. The wedge rubber coating shall be ethylene propylene diene (EPDM) rubber. Rubber mechanically attached with screws rivets and similar fasteners shall not be acceptable.

c) *2-inch Gate Valves*

- i) Valves shall meet or exceed all testing requirements set forth in AWWA C-509

d) *Plug Valve (16" and LARGER)*

- i) Supplier shall have been manufacturing eccentric plug valves for a period of at least ten (10) years. At the engineer's request, supplier shall provide a list of installations involving equipment of similar size and application.
- ii) Each valve and actuator shall be assembled, adjusted and tested as a unit by the valve manufacturer. Manufacturer shall provide certified copies of reports describing the procedures and results of the test for each model and the torque rating of the actuator.
- iii) Eccentric plug valves shall have a two-year warranty from date of shipment and at least 18 months from installation date. Manufacturer's name shall be cast into the body of valve and a metal tag containing a serial number shall be riveted to the valve for future parts identification.

e) *Insertion Valve (4" to 12")*

- i) Valves shall meet or exceed test specifications as set forth in AWWA C-515, latest revision, excluding in Section 5.1 Testing: 5.1.13 (leakage test), and 5.1.2.3 (seat test).

ii)

4. MANUFACTURER

a) *Valve Boxes*

- i) Valve box manufacturers shall have a domestic presence. Valve boxes shall be equal to or better than those made by Bingham & Taylor, Union Foundry, Sunshine Foundry, or Pipeline Components, Inc.

b) *Gate Valve*

- i) Standard valves shall be domestically assembled and shall be Clow F-6100, U. S. Pipe Metroseal 250, AVK Series 25, Mueller Co. (2360 for 2"-12", 2361 for 14"-24"), American Flow Control Series 500 or Series 2500, Kennedy KenSeal 4571, or approved equal.
- ii) Valves shall be domestically assembled and shall be equal to or better than Clow F-6136 OS&Y, U.S. Pipe Metroseal 250, or American Flow Control Series 2500-1.

c) *Tapping Valves*

- i) Tapping valves shall be domestically assembled and shall be equal to or better than Clow F-6114, U. S. Pipe Metroseal 250, Mueller Co. (2360 for 2"-12", 2361 for 14"-24"), American Flow Control Series 500 or Series 2500, Kennedy KenSeal 7571, American AVK Series 25, or approved equal.

d) *2-inch Gate Valves*

- i) All valves shall be domestically assembled and shall be equal to or better than the following:
 - (1) Push-on end valves - Clow 6110 (for PVC)/6100 (for MJ); Waterous Series 500 - P.O.; AVK Series 45
 - (2) Threaded end valves - Clow 6103; Waterous Series 500; American Flow Control Series 2500; AVK Series 03

e) *Plug Valve (16" and LARGER)*

- i) Valves shall be domestically assembled, DeZURIK 100 % Port Eccentric Plug Valve, PEF.

f) *Insertion Valve*

- i) Insertion valves shall be domestically manufactured. Insertion valves shall be Team Industrial Services "Team InsertValve", or approved equal.

W-30 RESTRAINT DEVICES

1. GENERAL

This section includes all restraint devices on pipe to be owned and maintained by the City of Tampa Water Department. Requirements of this section apply to all restraint devices unless exceptions are shown or stated on the plans or specific provisions.

Mechanical restraint devices shall be used to restrain plain ends of ductile iron or PVC pipe to push-on, mechanical, or flange joints which meet ANSI/AWWA C-110/A21.10 and ANSI/AWWA C-111/A21.11, or to restrain joints on existing installed pipes.

2. PRODUCT

a) *Ductile Iron Pipe Restraints*

i) Push-on Joint pipe Restraint (for 4" - 36" pipe only)

(1) Restraint shall be produced by "locking gaskets" consisting of an EPDM rubber gasket with high-strength stainless steel locking elements vulcanized into the gasket, which when activated develop wedging action between the pairs of stainless steel elements spaced around the gasket.

(2) Shall withstand the following working pressures:

(i) 4" - 16" = min. 350 psi

(ii) >16" = min. 250 psi

(3) Restraint gaskets shall be UL Listed and FM approved.

ii) Flange Joint Restraint

(1) Shall attach to the plain end of a pipe by wedge screws to produce a flange which joins to an existing integral companion flange.

(2) Shall be constructed of ductile iron meeting ASTM A536 and manufactured in accordance with ANSI/AWWA C-110/A21.10 and C-111/A21.11.

(3) Shall meet ANSI/AWWA C-110/A21.10 and ANSI/AWWA C-111/A21.11, latest revisions.

(4) Flanges shall have bolt circle and bolt holes which match a Class 125 flange and are compatible with ANSI/AWWA C-115/A21.15.

(5) Gaskets shall be full faced and made of EPDM rubber.

(6) Shall withstand 250 psi working pressure.

iii) Mechanical Joint Restraint

(1) Restraint shall be provided with wedge action devices.

(2) Restraint shall be incorporated in the design of the follower gland and shall include a restraining mechanism (the lug) which, when activated, imparts multiple wedging actions against the pipe, thereby increasing its restraint on the pipe as the joint tries to separate. "Twist-off nuts" shall be used to ensure proper actuating of the restraining device.

(3) Follower glands shall be manufactured of ductile iron conforming to ASTM A536-80.

(4) Wedging lug and bolt shall be manufactured of ductile iron which has been heat-treated to a minimum hardness of 370 BHN.

(5) Glands shall be dimensioned such that they can be used with standard mechanical joints and have tee-head bolts conforming to ANSI/AWWA C-111/A21.11 and ANSI/AWWA C-153/A21.53, latest revision.

(6) Pipe restrained with retainer glands specified shall be capable of withstanding twice the rated pressure of the restraint device for five minutes with no leakage or movement.

(7) Wedge action restraints shall withstand the following working pressures:

(i) 4" - 16" = min. 350 psi

(ii) >16" = min. 250 psi

iv) Existing Pipe Joint Restraint

(1) Restraint shall be provided with wedge action mechanical devices.

(2) Split-restraint fittings for mechanical joints on existing pipe installations shall be segmented.

(3) Split-restraint fittings for existing pipe bell-and-spigot joints shall consist of a split restraint ring installed on the pipe barrel behind the bell.

(4) Restraint devices shall be ductile iron per ASTM A536, latest revision, min. Grade 60-42-12. Threaded rods shall be high strength low-alloy steel per ANSI/AWWA C-111/A21.11.

b) *PVC Pipe Restraints*

i) Push-on Joint Restraint is not approved for PVC pipe. New PVC pipe longitudinal installations requiring restraint shall be with PVC pipe manufactured to provide restraint when the pipe's bell-and-spigot is assembled (i.e., manufactured restrained joint PVC pipe, such as Eagle Loc 900 or Certa-Lok).

ii) Restraints connecting and appurtenances shall be the following:

(1) Restraint provided shall be incorporated in the design of the follower gland and shall utilize multiple wedge segments acting against the pipe and increasing their resistance as the line pressure increases. The assembled joint shall maintain the maximum flexibility and deflection of all nominal pipe sizes after burial.

(2) Restraining gland, wedge segments, and actuating bolts shall be manufactured of high strength ductile iron conforming to the requirements of ASTM A536, Grade 65-45-12.

(3) Restraining rods & nuts shall be made of high strength, low alloy steel meeting AWWA/ANSI C111/A21.11 with minimum 65,000 psi tensile strength and 45,000 psi yield strength.

(4) Dimensions shall be compatible with standardized mechanical joints conforming to the requirements AWWA C111/ANSI A21.11 and AWWA C153/ANSI 21.53).

(5) Breakaway tops shall be incorporated in the design of the actuating bolts to visually ensure proper torque.

(6) The manufacturing of the actuating bolt must incorporate a quality control procedure deemed acceptable to positively assure precise and consistent operating torque of the breakaway top.

(7) Restraining devices shall have a working pressure rating of 235 psi and provide no less than a safety factor of 2:1.

(8) Restraint shall be FM approved in applicable sizes.

(9) Coating shall be with MEGA-BOND®, or an Alkyd paint.

iii) Restraints for existing push-on PVC pipe joints (bell-and-spigots) shall be the following:

- (1) Restraint shall be provided by two split retainer rings having a series of machined (not “as cast”) serrations that provide positive restraint and full support of the pipe wall. One split serrated clamping ring shall be installed on the spigot (plain end) pipe for connection to a second clamping ring to be located on the pipe barrel, immediately behind the gasketed bell, with necessary restraining rods and nuts connecting the bell ring to the gripping ring. Devices shall carry a minimum 2:1 safety factor.
- (2) Manufactured of ductile iron conforming to ASTM A536, grade 65-45-12.
- (3) Coated with MEGA-BOND®, or an Alkyd paint.

3. QUALITY CONTROL AND TESTING

When submitting for approval of restraint devices not listed in Section 4, include manufacturer drawings and brochures that clearly indicate size, dimensions, weights, performance standards, etc. If this documentation is omitted, the restraint fittings may be rejected at the sole option of the City.

a) *Ductile Iron Pipe Restraints*

i) Coatings

- (1) Flange Adapters shall be provided with painted "shop coat", or approved equal.
- (2) Retainer glands shall be provided with a bituminous coat.
- (3) Existing pipe push-on joint restraint fittings shall be provided with a bituminous coat.

ii) Burst pressure tests shall be performed as specified in ANSI/AWWA111/A21.11, latest revision.

b) *PVC Pipe Restraints*

- i) Restraining devices shall meet or exceed all requirements of ASTM F1674 “Standard Test Method for Joint Restraint Products for Use with PVC Pipe”.
- ii) Pipe restrained with retainer glands specified shall be capable of withstanding twice the rated pressure of the restraint device for five minutes with no leakage or movement.

4. MANUFACTURER

a) *Ductile Iron Pipe Restraints*

- i) Ductile iron pipe push-on joint restraint devices shall be U.S. Pipe "Field-Lok” Gasket, American "Fast-Grip" Gasket, or approved equal.
- ii) Ductile iron pipe flange joint restraint devices shall be approved, equal to, or better than EBAA Iron “Megaflange Series 2100” or “1000 EZ Flange”, or Ford Meter Box Company “Uni-flange Series 400-C”, or approved equal.
- iii) Wedge action restraint for ductile iron pipe mechanical joints shall be equal to or better than EBAA Iron “Megalug, Series 1100”, Tyler/Union TUF Grip TLD, Sigma One-Lok Model SLD, or approved equal.
- iv) Split, wedge-action restraints devices for restraint of existing pipe and fitting joints shall be approved, equal to, or better than EBAA Iron “Megalug, Series 1100SD or HD”, or approved equal.

b) *PVC Pipe Restraints*

- i) Restraint of Existing PVC pipe bell-and-spigots, such as the Uniflange 1350C, Uniflange 1390C, Megalug 1600, Sigma PV-Lok Series PVP, or approved equal.
- ii) Restraint of PVC pipe spigot-end to mechanical joint of fittings or valves, such as the Megalug 2000PV, Tyler/Union TUF Grip TLP, Uniflange 1300C, Sigma One-Lok Models SLC or PVM, or approved equal.
- iii) Manufactured restrained joint PVC pipe shall be Eagle Loc 900, Certa-Lok, or approved equal.

W-40 BRASS FITTINGS

1. GENERAL

All brass fittings for service lines shall be included under this specification.

2. PRODUCT

- a) All fittings shall be manufactured of brass, cast and machined in accordance with AWWA Standard C-800, latest revision.
- b) All fittings shall perform in accordance with AWWA C-800, latest revision.
- c) All brass fittings shall be made of a “No-Lead Brass”, defined for this specification as brass alloy containing not more than one fourth of one percent (0.25% or less) total lead when used with respect to the wetted surfaces of the fitting, as defined by NSF/ANSI 61.
- d) All fittings shall be certified as suitable for contact with drinking water in accordance with ANSI/NSF Standard 61, Drinking Water Components – Health Effects, Section 8. Certification shall be by an accredited certification organization or by a laboratory able to demonstrate that the NSF 61 lead testing protocol was followed.
- e) All brass fittings shall comply with Florida Administrative Code (F.A.C.) 62-555 (latest revision), the Safe Water Drinking Act, as amended, and the U.S Environmental Protection Agency (E.P.A.).
- f) All brass fittings shall be integrally stamped or cast with the manufacturer's name and a marking or trademark identifying that the fitting contains a “no lead” brass alloy (as defined herein), e.g., ‘NL’, ‘EB2’, or ‘FED’, etc.
- g) Curb Stops & Meter Valves
 - i) All curb stops shall be full-port and have a flow passage area equivalent to the fitting outlet flow area.
 - ii) Curb stops shall be of the ball valve design with a full-port opening ball no less than 3/4-inch. 3/4-inch curb stops shall be provided without padlock wings.
 - iii) 1-in. and larger curb stops shall be provided with padlock wings cast on stop body and operating tee cap to provide for locking the stop in closed position.
 - iv) Curb stops for use with copper or plastic service shall have an inlet connection with a pack-joint compression nut (w/ set screw) and an outlet connection with female iron pipe thread (FIP), or shall have an Inside Iron Pipe Thread (FIP) inlet connection and an Inside Iron Pipe Thread outlet connection.

v) Meter valves shall be of the ball valve design with a full-port opening ball no less than 3/4-inch. Meter valves shall be provided with padlock wings cast on stop body and operating tee cap to provide for locking the stop in closed position. Meter valves for use with copper or plastic service shall have an inlet connection with a compression joint and a swivel nut outlet connection, or shall have an Inside Iron Pipe Thread (FIP) inlet connection and an Inside Iron Pipe Thread outlet connection.

h) Corporation Stops

i) Corporation stops shall be of the ball valve design. Corporation stop inlet connection shall be the AWWA Taper thread. The outlet connection shall be CTS pack-joint (w/ set screw) for copper or plastic tubing.

i) Brass Fittings

i) Branch connections shall be brass construction with copper compression joint inlet and male iron pipe size outlets.

ii) Meter re-setters shall be designed for use with standard 5/8"x3/4" and 1" water meters. Re-setters shall be constructed from brass fittings conforming to the specifications herein, with copper riser pipes. An angle ball valve shall be provided on the inlet riser, saddle nuts and gaskets on inlet and outlet. Pipe connections shall be (nominal) male iron pipe size meter thread on both inlet and outlet.

iii) Threaded fittings

(1) Threaded brass fittings ("Fittings") provided shall be manufactured in accordance with ANSI B16.15, 125 lb.

(2) Fittings shall be of material conforming to ASTM B62 or B584.

(3) Threads on all fittings shall be N.P.T. in conformance with ANSI B1.20.3, right hand and shall be smooth, clean and true to form.

(4) Fittings shall be legibly cast or dye stamped such that the manufacturer's name, initial or other mark can be easily identified.

3. QUALITY CONTROL AND TESTING

a) Manufacturer shall provide a copy of a letter from NSF International (on NSF letterhead) documenting compliance with NSF/ANSI 61 Annex F.

b) Certification of the standards must be available and provided, if requested by the City. If requested, an Affidavit of Compliance to these standards and specifications shall be signed and submitted by an officer of the manufacturing firm.

When submitting for approval of brass fittings not listed, include manufacturer drawings and brochures that clearly indicate size, dimensions, weights, performance standards, etc. If any of this documentation is omitted, the brass fittings may be rejected at the sole option of the City.

4. MANUFACTURER

a) Brass fittings and threaded brass fittings shall be domestically manufactured by Mueller Company, Ford Meter Box Company, A.Y. McDonald Mfg. Company, or approved equal.

- b) Curb stops with compression nut inlet connection and female iron pipe thread (FIP) outlet connection:
 - i) FMBC: B41-333-378-NL (for ¾-in), B41-xxx-W-NL (for ≥1-in)
 - ii) A.Y. McDonald: 76102-22 (for ¾-inch), and 76102-22-W (for ≥1-inch)
 - iii) Mueller: P-2517(2 or 0) N (as applicable) or approved equal.
- c) Curb stops with Inside Iron Pipe Thread (FIP) inlet connections and an Inside Iron Pipe Thread outlet connections shall be:
 - i) FMBC: B11-333-NL (for ¾-in), and B11-xxx-W-NL (for ≥1-in)
 - ii) A.Y. McDonald: 76101 (for ¾-in), and 76101-W (for ≥1-in)
 - iii) Mueller: B-20283N (for ¾-in), B-20200N (for ≥1-in), or approved equal.
- d) Meter valves:
 - i) Angle meter valve: FBMC BA43W, Mueller P-24258N, A.Y. McDonald 4602B-22, or approved equal.
 - ii) Straight meter valve (compression x swivel): FBMC B43W, Mueller P-24351N, A.Y. McDonald 6101MW-22, or approved equal.
 - iii) Straight meter valve (FIP x swivel nut): FBMC B13W, Mueller P-24350N, A.Y. McDonald 6100MW-22, or approved equal
- e) Corporation stops for sizes ¾” – 2” shall be:
 - i) FMBC FB-1000, A.Y. McDonald 4701B-22, Mueller P-25008N, or approved equal.
- f) Branch connections shall be:
 - i) FMBC U48, Mueller P-15363N, A.Y. McDonald 08U2M, or approved equal.
- g) Meter re-setters shall be:
 - i) FMBC VB40 Series, Mueller B-24118R, A.Y. McDonald Series 18, or approved equal.

W-41 MECHANICAL JOINT BOLTS-AND-NUTS

1. GENERAL

All mechanical joint bolts and nuts shall be manufactured in accordance with ANSI/AWWA C-111/A21.11, latest revision, and shall also adhere to the following specification.

2. PRODUCT

- a) All mechanical joint bolts shall be a Tee-head design with hexagonal nuts. Dimensions shall be in accordance with ANSI/AWWA C-111/A21.11.

- b) All bolts and nuts shall be manufactured of high-strength, low alloy steel in conformance with ANSI/AWWA C-111/A21.11 and ASTM A242, latest revisions.
- c) All bolts shall be designed for internal and external threads to conform to ANSI/ASME B1.1 and B1.2. Thread form shall conform to the standards and dimensions of the coarse-thread series Unified Coarse (UNC); external threads shall be made in compliance with Class 2A limits, and internal threads shall be made in compliance with Class 2B limits. The Contractor is advised that various HDPE MJ adapters may require longer than standard bolts to complete the installation.

3. QUALITY CONTROL AND TESTING

When submitting for approval of mechanical joint bolts and nuts not listed in Section 4, include manufacturer drawings and brochures that clearly indicate size, dimensions, weights, performance standards, etc. If this documentation is omitted, the mechanical joint bolts and nuts may be rejected at the sole option of the City.

4. MANUFACTURER

Mechanical joint bolts and nuts specified herein shall be domestically manufactured of Cor-Ten or approved equal by Birmingham Foundry, National Set Screw Corporation or approved equal.

W-42 OFFSETS

1. GENERAL

All ductile iron mechanical joint offsets shall be of ductile iron and manufactured in accordance with and ANSI/AWWA Standards C-110/A21.10 (or C-153/A21.53) and C-111/A21.11, latest revisions.

2. PRODUCT

- a.) Ductile iron mechanical joint offsets shall have a minimum pressure rating of 350 psi.
- b.) Joints shall be mechanical joints in accordance with C-111/A21.11, latest revision. All joint accessories shall be furnished with the fittings. Mechanical joint bolts and nuts shall be domestically manufactured of high-strength, low-alloy steel such as "Corten", "Usalloy", or "ACIPalloy". The follower gland shall be manufactured from ductile iron. The gasket shall be made of EPDM rubber.
- c.) Mechanical Joint fittings furnished shall have either of the exterior coating and interior lining systems described below:
 - (1) Cement Mortar Lining: Fittings furnished shall have a standard thickness cement mortar lining and be seal coated in accordance with ANSI/AWWA C-104/A21.4, latest revision. Fittings shall be listed NSF or by an approved certifying agency as conforming to all requirements of ANSI/NSF 61 and shall have an asphalt exterior coating which conforms to ANSI/AWWA C-110/A21.53.
 - (2) Fusion-bonded epoxy: Fittings shall be coated inside and out with a minimum 8 mils of fusion-bonded epoxy, and be in conformance with the requirements of ANSI/AWWA C-116/A21.16 and AWWA C-550, latest revisions. Fittings shall be listed by an approved certifying agency as conforming to all requirements of ANSI/NSF 61.

3. QUALITY CONTROL AND TESTING

- a) Ductile iron mechanical joint offsets shall meet or exceed pressure, hydrostatic and all other tests set forth in ANSI/AWWA C-110/A21.10 (or C-153/A21.53), latest revision.
- b) Submit in duplicate notarized certificates of conformance that all tests and inspections performed on ductile iron mechanical joint offsets as required by the ANSI/AWWA standards C-110/A21.10 (or C153/A21.53) have been satisfied.
- c) When submitting for approval of ductile iron mechanical joint offsets not listed in Section 4, include manufacturer drawings and brochures that clearly indicate size, dimensions, weights, performance standards, etc. If this documentation is omitted, the ductile iron mechanical joint offsets may be rejected at the sole option of the City.

4. MANUFACTURER

Ductile iron mechanical joint offsets shall be manufactured by U.S. Pipe and Foundry Co., American Ductile Iron Pipe, Sigma, Tyler-Union, Union Foundry, or approved equal.

W-43 SOLID SLEEVES

(Ductile Iron, Compact, MJ)

1. GENERAL

Solid sleeves shall be used to join two plain ends of pipe or repair a damaged pipe.

2. PRODUCT

- a.) Solid sleeve lengths shall be up to 24-inches. The solid sleeve shall be capable of having two plain ends of pipe inserted into opposite ends of the sleeve. The sleeve is then to be sealed to the pipe by a mechanical joint at each end of the sleeve.
- b.) All sleeves shall be manufactured of ductile iron. Solid sleeves shall be manufactured in accordance with ANSI/AWWA Standard C-153/A21.53, latest revision. All sleeves shall be rated for a minimum working pressure of 350 psi.
- c.) All solid sleeve sealing ends shall be mechanical joints in accordance with ANSI/AWWA C-111/A21.11, latest revision. All joint accessories shall be furnished with the fittings. All bolts and nuts shall be made of high-strength, low-alloy steel such as "Corten", "Usalloy", or "Acipalloy". The gasket shall be for a standard Mechanical Joint, in accordance with ANSI/AWWA C-111/A21.11, latest revisions, and be made of EPDM rubber. The follower gland shall be manufactured from ductile iron at least ASTM A536, Grade 70-50-05 in accordance with ANSI/AWWA C-111/ A21.11, latest revision
- d.) All ductile iron compact solid sleeves shall be furnished with a standard thickness cement mortar lining and seal coating in accordance with AWWA Standard C-104, latest revision.
- e.) Fittings shall have an exterior, asphaltic coating which conforms to ANSI/AWWA C-153/A21.53.

3. QUALITY CONTROL AND TESTING

- a) All solid sleeves shall meet or exceed all testing requirements of ANSI/AWWA C-153/A21.53.
- b) When submitting for approval of solid sleeves not listed in Section 4, include manufacturer drawings and brochures that clearly indicate size, dimensions, weights, performance standards, etc. If this documentation is omitted, the solid sleeves may be rejected at the sole option of the City.

4. MANUFACTURER

All ductile iron mechanical joint solid sleeves shall be manufactured by U.S Pipe, Sigma, Tyler/Union, American Cast Iron Company, Clow, or approved equal.

W-44 COMPACT ANCHOR FITTINGS - DUCTILE IRON

1. GENERAL

Ductile Iron Compact Anchor Fittings ("Fittings") provided under this specification shall be manufactured in accordance with AWWA Standard C-153 and C-111, latest editions, and as specified herein. Joint accessories shall be provided with fittings.

2. PRODUCT

- a) Tees
 - i) Both joints on the run of all anchor tees shall be mechanical joint in accordance with AWWA Standard C-111, latest edition.
 - ii) All mechanical joints shall be supplied with a joint accessories package (bolts, nuts and gasket) as part of the anchor fitting. MJ Gaskets shall be made of EPDM rubber formulated to resist chloramine degradation. All anchor fittings shall be compatible with mechanical joint connections in accordance with AWWA C-111, latest edition, and shall be capable of mechanical restraint so as to eliminate the need for additional thrust restraints.
 - iii) The standard anchor tee branch shall have an anchoring "plain end" which includes an integral or split follower gland, suitable for connecting to mechanical joint fitting meeting ANSI/AWWA C-111/A 21.11.
- b) Anchor Elbow and Anchor Coupling
 - i) The Anchor x Anchor elbows and anchor couplings shall have for both ends anchoring "plain ends". These "plain ends" shall have integral or split follower glands, suitable for mechanical joint fittings meeting ANSI/AWWA C-111/A 21.11.
- c) Joint Accessories
 - i) All T-head bolts and nuts for joints shall be domestically manufactured high-strength, low-alloy steel such as "Corten", "Usalloy," or "ACIPalloy."

ii) All joint accessories shall be furnished with anchoring fittings.

iii) All gaskets shall be EPDM rubber.

(1) All anchoring fittings shall be furnished with either: i) a standard thickness cement mortar lining seal coated in accordance with AWWA Standard C-104, latest edition, and an exterior, asphalt coating which conforms to ANSI/AWWA C-151/A21.51; or, ii) have factory-applied fusion bonded epoxy coatings both inside and outside, in accordance with AWWA C550.

(2) All fittings shall have a minimum pressure rating of 350 psi.

3. QUALITY CONTROL AND TESTING

- a) All anchor fittings shall meet or exceed acceptance, performance and hydrostatic testing in accordance with AWWA Standard C-153 and C-111, latest editions.
- b) When submitting for approval of ductile iron compact anchor fittings not listed in Section 4, include manufacturer drawings and brochures that clearly indicate size, dimensions, weights, performance standards, etc. If this documentation is omitted, the ductile iron compact anchor fittings may be rejected at the sole option of the City.

4. MANUFACTURER

Ductile iron compact anchor fittings shall be manufactured by U.S. Pipe and Foundry Company, Clow, American Ductile Iron Pipe, McWane, Pipeline Components, Inc. or approved equal.

W-45 COMPACT MECHANICAL JOINT FITTINGS-DUCTILE IRON

1. GENERAL

- a) Ductile iron compact mechanical joint fittings shall be manufactured in accordance with ANSI/AWWA C-153/A21.53, latest revisions and the specifications stated herein. Fittings shall be listed by the National Sanitation Foundation (NSF) and shall conform to the requirements of NSF-61.
- b) Whenever the word "fitting" is used in this specification, it shall mean "Compact Ductile Iron Mechanical Joint Fitting".

2. PRODUCT

- a) For fittings larger than 16-inches physical and chemical properties shall be in accordance with ANSI/AWWA C153/A21.53, latest revision. The minimum working pressure for fittings shall be 350. The minimum wall thickness shall not be less than that of pressure class 350 ductile iron pipe.
- b) Joints shall be Mechanical Joint in accordance with ANSI/AWWA C111/A21.11 and C153/A21.53, latest revision, with exceptions noted herein. Mechanical Joint bolts and nuts shall be domestically manufactured of high-strength, low-alloy steel such as "Corten", "Usalloy", or "ACIPalloy". Joints requiring a shorter bolt than called for in ANSI/AWWA C111/A21.11 shall be supplied as required. Gaskets for mechanical joints shall be made of ethylene propylene diene (EPDM) rubber.

c) Exterior Coating and Interior Lining

Mechanical Joint fittings furnished shall have either of the exterior coating and interior lining systems described below:

- i) Cement Mortar Lining: Fittings furnished shall have a standard thickness cement mortar lining and be seal coated in accordance with ANSI/AWWA C-104/A21.4, latest revision. Fittings shall be listed by an approved certifying agency as conforming to all requirements of ANSI/NSF 61 and shall have an asphalt exterior coating which conforms to ANSI/AWWA C-153/A21.53.
- ii) Fusion-bonded Epoxy: Fittings shall be coated inside and out with fusion-bonded epoxy, and be in conformance with the requirements of ANSI/AWWA C-116/A21.16 and AWWA C-550, latest revisions. Fittings shall be listed by NSF or by an approved certifying agency as conforming to all requirements of ANSI/NSF 61.

3. QUALITY CONTROL AND TESTING

- a) All fittings specified herein shall meet or exceed all hydrostatic, performance, and acceptance tests in accordance with ANSI/AWWA C153/A21.53 latest revision.
- b) When submitting for approval ductile iron compact MJ fittings not listed in Section 4, include manufacturer drawings and brochures that clearly indicate size, dimensions, weights, performance standards, etc. If this documentation is omitted, the ductile iron compact MJ fittings may be rejected at the sole option of the City.

4. MANUFACTURER

- a) All manufacturers of ductile iron compact MJ fittings specified herein shall have a domestic presence. The fittings shall be manufactured by U.S. Pipe, Clow, Tyler/Union Pipe, American Ductile Iron Pipe, McWane, Pipeline Components, Inc., Sigma, Star Pipe, or approved equal.

W-46 DUCTILE IRON FITTINGS

1. GENERAL

This section includes all fittings to be owned and maintained by the City of Tampa Water Department. Requirements of this section apply to all fittings unless exceptions are shown or stated on the plans or specific provisions.

2. PRODUCT

- a) All fittings shall be manufactured of ductile iron.
- b) All fittings below grade shall be mechanical joint.
- c) All mechanical joint bolts shall be a Tee-head design with hexagonal nuts, dimensioned in accordance with ANSI/AWWA C-111/A21.11.

- d) All bolts and nuts shall be manufactured of high-strength, low alloy steel in conformance with ANSI/AWWA C-111/A21.11 and ASTM A242.
- e) All fittings above grade shall be AWWA C110 flanges with a drilling that matches AWWA C115 and ANSI B16.1 class 125 flanges.
- f) Minimum Working Pressure
 - i) Mechanical Joint = 350 psi
 - ii) Flanged Joint = 250 psi
- g) Fitting shall be factory furnished with standard thickness cement lined interiors and asphaltic coated exteriors, or have fusion-bonded epoxy coating inside and out.
- h) Anchor tee branches shall have an anchoring "plain end" which includes an integral or split follower gland, suitable for connecting to mechanical joint fitting meeting ANSI/AWWA C-111/A 21.11.
- i) Anchor x Anchor elbows and anchor couplings shall have for both ends anchoring "plain ends". These "plain ends" shall have integral or split follower glands, suitable for mechanical joint fittings meeting ANSI/AWWA C-111/A 21.11.
- j) Gasket material shall be made of EPDM rubber.

3. QUALITY CONTROL AND TESTING

- a) Fittings shall be listed by the National Sanitation Foundation (NSF), or by an approved certifying agency as conforming to all requirements of ANSI/NSF 61.
- b) All mechanical joint fittings shall meet or exceed ANSI/AWWA C153/A21.53 or ANSI/AWWA C110/A21.10
- c) All flanged fittings shall meet or exceed ANSI/AWWA C110/C115/C153 and ANSI/ASME B16.1
- d) Cement lining shall be in accordance with AWWA C104/A21.04
- e) Asphaltic coatings shall meet or exceed ANSI/AWWA C110/A21.10
- f) Fusion-bonded coating and lining shall conform with AWWA C-116 and AWWA C-550, and be listed by NSF (or by an approved certifying agency as conforming to all requirements of ANSI/NSF 61).
- g) Gasket material shall be made of EPDM, in accordance with ANSI/AWWA C-111/A21.11, latest revisions. The follower gland shall be manufactured from ductile iron at least ASTM A536, Grade 70-50-05 in accordance with ANSI/AWWA C-111/ A21.11, latest revision
- h) Mechanical joint bolts and nuts shall be manufactured in accordance with ANSI/AWWA C-111/A21.11. All bolts shall be designed for internal and external threads to conform to ANSI/ASME B1.1 and B1.2. Thread form shall conform to the standards and dimensions of the coarse-thread series Unified Coarse (UNC); external threads shall be made in compliance with Class 2A limits, and internal threads shall be made in compliance with Class 2B limits.

4. MANUFACTURER

- a) Ductile iron fittings shall be manufactured by U.S Pipe, Sigma, McWane, Tyler/Union, American Cast Iron Pipe Company, Clow, or approved equal.
- b) Mechanical joint bolts and nuts shall be domestically manufactured of Cor-Ten or approved equal by Birmingham Foundry, National Set Screw Corporation, or approved equal.

W-47 FLANGED FITTINGS

(Standard Class 125)

1. GENERAL

All standard class 125 flanged fittings shall be manufactured in accordance with ANSI/AWWA Standard C-110/A21.10 and NAPF 200, latest revision.

2. PRODUCT

- a) Standard class 125 flanged fittings shall have a minimum pressure rating of 250 psi. Flanges shall be round type, faced and drilled and shall conform to ANSI B16.1 for cast-iron or bronze pipe flange Class 125.
- b) The joints shall be flanged in accordance with ANSI/AWWA C-110/A21.10 and NAPF 200, latest revision. All necessary hex-head bolts and nuts, and full-faced gaskets for each joint shall be furnished as a Flange Accessory Package and shall conform to ANSI B18.2.2; threads shall be manufactured in accordance with ANSI B1.1. Bolts and nuts shall be high-strength, low-alloy steel such as "Corten", "Usalloy", or "ACIPalloy". Bolt circle and bolt holes shall be drilled and faced to match American National Standard Institute (ANSI) B16.1, Class 125 Flanges.
- c) All standard class 125 flanged fittings shall have a standard thickness cement mortar lining and shall be seal coated in accordance with AWWA Standard C-104, latest revision.

3. QUALITY CONTROL AND TESTING

- a) All standard class 125 flanged fittings shall meet or exceed all test standards set forth in AWWA C-110.
- b) When submitting for approval of standard class 125 flanged fittings not listed in Section 4, include manufacturer drawings and brochures that clearly indicate size, dimensions, weights, performance standards, etc. If this documentation is omitted, the standard class 125 flanged fittings may be rejected at the sole option of the City.

4. MANUFACTURER

Standard class 125 flanged fittings shall be manufactured by U.S. Pipe and Foundry Co., American Ductile Iron Pipe, PCI, Tyler-Union, Sigma, or approved equal.

W-60 FIRE HYDRANT ASSEMBLY

1. GENERAL

This section includes all hydrants to be owned and maintained by the City of Tampa Water Department. Requirements of this section apply to all hydrant assemblies unless exceptions are shown or stated on the plans or specific provisions.

2. PRODUCT

a) Pipe

i) See *Ductile Iron Pipe* Specifications

b) Valve

i) See *Valve* Specifications

c) Fittings

i) See *Fittings* Specifications

d) Hydrant

i) Hydrants shall have a 5¼-inch main valve opening. The main valve shall be of compression-design and shall open against and closing with pressure. The hydrant shall comply with the requirements of Associates Factory Mutual Insurance Companies and have the "FM" symbol cast into the barrel. The hydrant shall be listed with Underwriter's Laboratories. Hydrants shall open by turning the operating nut counterclockwise.

ii) The hydrant shall be provided with a breakable traffic feature designed so that the nozzle section of the hydrant can be rotated a full 360 degrees. Break couplings shall be made of cast iron, epoxy coated steel, or forged stainless steel. The lower barrel and shoe shall be made of ductile iron, manufactured in accordance with AWWA C-502, latest revision.

iii) All hydrants shall have two 2½-inch bronze nozzles, 180 degrees apart, and one 4½-inch bronze nozzle. All nozzle centerlines shall be at the same elevation. Nozzle outlet threads to be National Standard fire hose coupling screw thread, as described in Appendix A of AWWA C-502. After being coated with an approved anti-seize compound as specified herein, hydrant nozzle shall thread or twist-lock into the hydrant nozzle section; a locking device secures the nozzle. Cast iron or ductile iron nozzle caps provided, with gaskets; nozzle cap nut configuration matches hydrant operating nut. Chains are not provided on nozzle caps.

iv) Hydrant design shall be such that removal of the seat valve drain mechanism, internal rod and all working parts can be accomplished through the top of the hydrant without disturbing the ground-line joint or nozzle section. The shoe inlet shall be mechanical joint, in accordance with AWWA C-111, latest revision. The interior of the shoe and (and upper and lower valves plates, if utilized in design) shall be epoxy-coated in accordance with AWWA C550, latest revision. Accessory kits shall be provided with MJ bolts and nuts and gasket. Mechanical joint nuts and bolts to be manufactured of high-strength, low-alloy steel equal to or better than "Cor-Ten". Main valve gasket and mechanical joint (MJ) gasket made of EPDM.

- v) All above-ground external bolts, studs, and nuts made of low-zinc bronze or stainless steel. Below-ground bolts, studs and nuts shall be made of high-strength, low-alloy steel as specified herein, or of stainless steel. When bolts are used at the break coupling, they shall not be frangible.
- vi) Unless the operating rod is made of stainless steel, the rod shall be sheathed where it passes through a double O-ring seal, sealing the operating threads from the water in the hydrant at all times when the valve is in the open or closed position. Another O-ring shall prevent water from passing between the operating shaft and the sheath. Downward travel of the operating rod and valve assembly shall be controlled by a travel stop device (located in the bonnet only), to prevent the bottom of the main valve from making contact with the epoxy coating of the shoe. Travel stop devices located on the bottom of the operating rod are not acceptable. Bronze operating nuts shall be fully covered with a cast iron or ductile iron weather shield and shall have at least one anti-friction thrust washer to reduce the operating torque when opening the hydrant. The hydrant's bronze main valve seat ring shall thread into a bronze sub-seat or drain ring. The drain outlet for the hydrant shall be eliminated as part of the casting or machining process.
- vii) Hydrant operating threads shall be lubricated with anti-seize compound paste upon assembly. Approved anti-seize compounds are Bostik Never-Seez food-grade (888-603-8558), or Permatex part #82448 (food-grade anti-seize compound). (877-376-2839), or MobilGrease FM102 (food-grade). Approval for other anti-seize compounds shall be requested in writing to the Tampa Water Department, accompanied with a Material Safety Data Sheet from the manufacturer of the compound for review. Anti-seize compound shall not contain any heavy metals.
- viii) When the hydrant is tested for head-loss as described in AWWA C502, Section 5, latest revision, the maximum head-loss shall not exceed 2.5 psi when flowing at 1000 gpm through the 4 ½-inch nozzle.
- ix) Hydrant coatings shall be as specified in AWWA C502 Section 4.02. Additionally, above-ground exterior hydrant coatings shall be minimum 4 mil Dry Film Thickness white primer coating, compatible with Porter high-grade enamel final paint to be applied in the field. Color will be specified by inspector.
- x) If manufacturer uses locking keys to secure the lower barrel to the shoe, all locking keys to be fully coated with a Water Department approved anti-seize compound applied upon assembly

3. QUALITY CONTROL AND TESTING

- a) Pipe
 - i) See *Ductile Iron Pipe* Specifications
- e) Valve
 - i) See *Valve* Specifications
- f) Fittings
 - i) See *Fittings* Specifications
- g) Hydrant
 - i) The following shall be provided upon request of the Engineer:

- (1) Certified affidavit from an officer of the manufacturer that hydrant conforms to AWWA C502, latest revision, and these specifications.
- (2) Certified test results from an independent testing laboratory indicating that the hydrant conforms to Section 2.8 of this specification.
- (3) Certification of Underwriter's Laboratories listing.
- (4) Certification of compliance with Associates Factory Mutual Fire Insurance Companies specifications.

2) MANUFACTURER

- a) Pipe
 - i) See *Ductile Iron Pipe* Specifications
- b) Valve
 - i) See *Valve* Specifications
- c) Fittings
 - i) See *Fittings* Specifications
- d) Hydrant
 - i) Hydrants shall be assembled and tested in their entirety within the United States of America or its territories. The manufacturer of hydrants shall have continuously manufactured, catalogued, sold, and had in service the hydrants in the size proposed for a minimum of five years.

Hydrants shall be manufactured by American (Darling B-84-B 5¼), U.S. Pipe (Metro 250 M94, 5 ¼), Kennedy (Guardian K81-D, 5¼), American AVK (Series 2780, Nostalgic, 5¼), or approved equal.

W-70 TAPPING SLEEVES

(Steel, "O-Ring" Type)

1. GENERAL

Tapping sleeves (steel/"O-ring" type) shall be constructed of high strength steel and shall be manufactured in accordance with ASTM A285. Steel tapping sleeves shall be suitable for tapping ductile iron pipe, C-900 PVC pipe, and all pipe manufactured in accordance with ANSI A21 Standards, AWWA, and these specifications.

2. PRODUCT

- a) All tapping sleeves (steel or "O-ring" type) shall be split sleeve design; one half shall contain the outlet hub, gasket and tapping flange; the other half shall form the back. A ¾" NPT test plug shall be provided on the outlet throat of the sleeve for pressure testing the sealed sleeve at 150 psi prior to tapping the pipe. All tapping sleeves shall allow a full-size cutting head to pass through the outlet of the hub.
- b) All bolts and nuts joining the two halves of the sleeve shall be high strength, low alloy steel, such as Cor-Ten, in accordance with AWWA C-111, latest revision.

- c) All tapping sleeve connection flanges shall be a Class 125 flanged joint, conforming to AWWA C207 Class D, ANSI 150 lb. with a counter bore per MSS SP-60 dimensions.
- d) Tapping sleeves shall seal to the pipe by the use of a confined "O-ring" gasket around the tap opening between the sleeve and pipe or by a full circumferential gasket between the sleeve and pipe. Gasket shall be made of EPDM rubber.
- e) All steel tapping sleeves shall be finished with fusion-bonded epoxy coating both inside and outside, in accordance with AWWA C-550, latest revisions.

3. QUALITY CONTROL AND TESTING

When submitting for approval tapping sleeves ("O-ring" type) not listed in Section 4, include manufacturer drawings and brochures that clearly indicate size, dimensions, weights, performance standards, etc., which completely substantiates the tapping sleeves compliance with this specification. If this documentation is omitted, the tapping sleeves may be rejected at the sole option of the City.

4. MANUFACTURER

Tapping sleeve (steel/"O-ring" type) manufactures shall be domestically assembled. Tapping sleeves (steel/"O-ring" type) shall be manufactured by JCM 412, Smith Blair 622, Ford Meter Box FTSC, Dresser 610, Mueller H615, U.S. Pipe T9, or approved equal.

W-71 TAPPING SLEEVES

(Mechanical Joint)

1. GENERAL

Tapping sleeves (mechanical joint) shall be constructed of ductile iron. All tapping sleeves shall be suitable for tapping cast iron, ductile iron pipe, C-900 PVC pipe, and all pipe manufactured in accordance with ANSI A21 Standard, AWWA, and these specifications.

2. PRODUCT

- a) Tapping sleeves shall be of the split sleeve design; one half shall contain the outlet hub, gasket, and tapping flange; the other shall form the back of the sleeve. A ¾" NPT test plug shall be provided on the outlet throat of the sleeve for pressure testing the sealed sleeve at 150 psi prior to tapping the pipe. All tapping sleeves shall allow a full-size cutting head to pass through the outlet of the hub.
- b) Tapping sleeves shall be constructed of ductile iron and shall be manufactured in accordance with ASTM A536.
- c) All bolts and nuts joining the two halves of the sleeve shall be high strength, low alloy steel, such as Cor-Ten, in accordance with AWWA C-111, latest revision.

- d) Tapping sleeve connection flanges shall conform to AWWA C-110/ANSI B16.1 Class 125 with counter bore per MSS SP-60 dimensions.
- e) Mechanical joint tapping sleeves shall form a mechanical joint at each end of the sleeve after bolting the halves together. The sleeve shall then be sealed to the pipe by assembling the mechanical joint using split gaskets and follower glands.
- f) All ductile iron sleeves shall have an outside bituminous coating in accordance with AWWA C-110, latest revision.
- g) End and side gaskets shall be made of EPDM rubber.

3. QUALITY CONTROL AND TESTING

When submitting for approval of tapping sleeves (mechanical joint) not listed in Section 4, of this specification include manufacturer drawings and brochures that clearly indicate size, dimensions, weights, performance standards, etc. If this documentation is omitted, the tapping sleeves (mechanical joint) may be rejected at the sole option of the City.

4. MANUFACTURER

Tapping sleeve (mechanical joint) shall be domestically assembled. Tapping sleeves (mechanical joint) shall be manufactured by U.S. Pipe Mechanical Joint Tapping Sleeve, Mueller Co. H-615, American Flow Control or approved equal.

W-80 METER SET ASSEMBLY

1. GENERAL

This section includes all meters to be owned and maintained by the City of Tampa Water Department. Requirements of this section apply to all meters unless exceptions are shown or stated on the plans or specific provisions.

2. PRODUCTS

- a) Meter laterals
 - i) See *HDPE Tubing* specification
- b) Curb and Corporation Stop
 - i) See *Brass Fittings* specification
- c) Meter
 - i) Shall be capable of operating at 150 psi
 - ii) The unit of measure shall be in 100 Cubic Feet (ccf)
 - iii) Shall have a life expectancy of 20 years
 - iv) Shall be magnetic-driven, positive displacement meters of the flat nutating disc type

- v) All meters must be adaptable to a field programmable absolute encoder register without interruption of the customer's service.
- vi) All main case bolts shall be of 300 series non-magnetic stainless steel to prevent corrosion.
- vii) End connections for 1½" and 2" meters shall be either spud type in accordance with ANSI 1.20.1 or oval flange type with gaskets at the City's option.
- viii) Numerals on odometer shall be black on white background except for the two right most numerals which shall be white on black background.
- ix) Direct Read Standard Register
 - (1) The register shall be of the straight reading sealed magnetic drive type and shall contain six (6) numeral wheels.
 - (2) Registers must be hermetically sealed.
 - (3) All direct reading register cups shall be copper to prevent corrosion and be covered with a high strength, impact resistant flat glass lens to prevent breakage.
 - (4) The lens shall be positioned above the register box to allow for run-off of debris. The register lid shall overlap the register box to protect the lens.
 - (5) Registers shall have a bronze or synthetic polymer register box enclosure with the manufacturer's serial number imprinted on top of a hinged reading lid.
 - (6) All registers shall have the size, model and date of manufacture stamped on the dial face. The dial shall have a red center sweep hand and shall contain one hundred (100) equally divided graduations at its periphery.
 - (7) The register must contain a low flow (leak detection) indicator with a 1:1 ratio to disc nutation's to provide leak detection.
 - (8) Registers shall be secured to the maincase by means of a plastic tamper-proof seal to allow for inline service replacement. Register seal screws are only accepted when supplied with attached sealing wire to at least one bottom cap bolt with seal wire holes of not less than 3/32" in diameter.
 - (9) Registers shall be guaranteed for at least ten (10) years. All meters will be guaranteed for one year on material and workmanship.
- x) Measuring Chamber
 - (1) The measuring chamber shall be of a two-piece snap-joint type with no fasteners allowed. The chamber shall be made of a non-hydrolyzing synthetic polymer.
 - (2) The control block shall be the same material as the measuring chamber and be located on the top of the chamber. The control block shall be located after the strainer.
 - (3) The measuring chamber outlet port shall be sealed to the maincase outlet port by means of an "O" ring gasket.

(4) The flat nutating disc shall be a single piece made from non-hydrolyzing synthetic polymer and shall contain a type 316 stainless steel spindle. The nutating disc shall be equipped with a synthetic polymer thrust roller located within the disc slot. The thrust roller head shall roll on the buttressed track provided by the diaphragm.

d) Meter Box & Covers

- i) Water meter boxes (“Meter Boxes”) and covers (“Covers) shall be manufactured in accordance with these specifications. Covers provided shall be designed to withstand incidental traffic or heavy traffic (“extra-heavy”) loading.
- ii) Meter boxes and covers provided shall be in accordance with City of Tampa Water Department “Standard Details” for meter boxes (see Std. Details 5.10A, 5.11A, 5.12A & 5.13).
- iii) Meter boxes and covers provided for potable water service shall be black in color.
- iv) Meter boxes and covers provided for reclaimed water (RCW) service shall be colored Pantone purple. Covers for RCW meter boxes shall include “NO BEBER”, and the universal symbol for DO NOT DRINK [the glass with a line (or “x”) through it].

e) Meter Boxes

- i) Meter boxes shall be LLD- or HD-polyethylene of one-piece molded construction, with dimensions as shown in the referenced drawings. The boxes shall be designed to meet the requirements for AASHTO Incidental Traffic H-10 loading.
- ii) All edges shall be clean and smooth for safety during handling. Exterior wall shall be of smooth finish, black in color, and have ultraviolet degradation protection properties for above ground storage (except reclaimed water meter boxes shall be purple). Interior wall shall be of smooth finish and black or white color (except reclaimed water meter boxes shall be purple).
- iii) Meter boxes shall not exceed 25 lbs. in weight, shall have pre-cut pipe entry areas, and be designed to be securely stackable.

f) Meter Box Covers

Meter box covers shall:

- i) be made of modified polyethylene or bulk molded compound composite material to prevent floating in high water conditions; be one-piece molded construction, with dimensions and lettering as shown in the referenced meter box Std. Detail drawings;
- ii) be designed to meet the requirements for AASHTO Incidental Traffic H-10 loading;
- iii) be “anti-float”, demonstrated by having a specific gravity $>1.0 \text{ gm/cm}^3$ (ASTM D792);
- iv) include snap-lock pockets (slide mounts) on the underside to receive an AMR/AMI device endpoint. Snap-lock slot shall be of size sufficient to allow for a finger force install of an AMI transmitter, and pocket height shall be sufficient to allow a minimum 1/8” air gap;

- v) include minimum #3 rebar or other tested and proven means of enabling magnetic location of the cover when it is buried;
- vi) be sized to fit the appropriate Brooks Products, Inc., Orlando, Florida concrete meter boxes, numbers 36, 37, 66 and Dual H:

| Description | ¾" Dual | ¾" or 1" Single | 1½"-2" Single | Dual w/BFP |
|-----------------|----------------|-------------------|-------------------|---------------|
| Meter Box Type | Dual H | #37 | #66 | 13 x 24 |
| Meter Box Cover | 16-9/16" x 14- | 18-1/8" x 11-1/4" | 30-1/2" x 17-1/2" | 13 ¾" x 23 ¼" |

- vii) Composite covers shall have a minimum coefficient of friction of >0.5 (ASTM 1028), to prevent pedestrian slip hazard.
- viii) Polyethylene covers shall have a molded tread-pattern for skid resistance.
- ix) "Extra-heavy" covers provided shall be designed to meet the requirements for AASHTO Full Traffic H-20 loading.

3. QUALITY CONTROL AND TESTING

- a) Laterals
 - i) See *HDPE Tubing* specification
- b) Curb and Corporation stop
 - i) See *Brass Fittings* specification
- c) Meter
 - i) Brass shall meet SDWA Section 1417 lead free requirements and comply with NSF/ANSI Standard 61.
 - ii) Must provide documentation of compliance with NSF/ANSI Standard 61. Certification of meter compliance to the NSF performance standard shall be by NSF, UL, or any other ANSI-accredited laboratory.
 - iii) To ensure accuracy, each meter must be accompanied by a factory test tag certifying the accuracy at the flows required by AWWA C700.
 - iv) Markings on the upper portion of the casing shall be cast raised and shall indicate size, model, direction of flow, and NSF 61 certification.
 - v) Shall conform to AWWA Standard C700 (latest revision)
 - vi) Shall be manufactured in a ISO 9001 facility
- d) Meter Box Cover
 - i) All covers must offer a minimum of a full 10-year warranty against defects, breakage, etc., under normal use conditions.

- ii) All HDPE “standard” meter box covers shall be designed to meet the requirements for AASHTO Incidental Traffic H-10 loading. All HDPE “extra-heavy” covers shall meet the requirements for AASHTO Full Traffic H-20 loading.
- iii) All covers shall have UL/FM approvals.

4. MANUFACTURER

a) Laterals

- i) See *HDPE Tubing* specification

b) Curb and Corporation stop

- i) See *Brass Fittings* specification

c) Meter

- i) Meters and meter parts shall be manufactured, assembled, and tested within the United States. Manufacturers may be required to provide proof of where and what percentage of the meter register, chamber, and maincase is manufactured in the United States. Manufacturers shall have a minimum of fifteen (15) years of field and production experience with all sizes and models provided.

d) Meter Box & Covers

Water meter boxes and meter box covers provided shall be equal to or better than:

i) Meter Boxes:

- (1) DFW Plastics, models: DFW37C-12-BODY; DFW39C-12-BODY; DFW1730CH-12-BODY; DFW 1324C-12-BODY (for RCW boxes, insert a 5 after the “C “or “CH” in the model name)
- (2) 1015-12 Oldcastle Enclosure Solutions, models: CFXL (#36); 1118-12 BCFXL (#37); 1416-12 BCFXL (Dual); 1730-12 BCFXL (#66); 1324-12 BCFXL (Dual Meter & w/BFPs).

ii) Meter Box Covers:

- (1) DFW Plastics, models: DFW37C-AF1EA TPA-LID; DFW39C-AF1EATPA-LID; DFW1730C-AF1EA TPA LID; DFW1324C-AF1EA TPA-LID (for DFW RCW covers, change the 1 to a 5 in the model name)
- (2) Oldcastle Enclosure Solutions “Fibrelyte”, models: FL9X (36), FL12 (37), FL1416 (Dual), FL36 (66), FL30 (Dual BFP)

W-90 BLOW-OFF ASSEMBLY

1. GENERAL

This section includes all blow-off assemblies to be owned and maintained by the City of Tampa Water Department. Requirements of this section apply to all blow-off assemblies unless exceptions are shown or stated on the plans or specific provisions.

Blow-off assemblies shall be used to remove sediments and stagnant water from non-looping or dead-end water lines.

2. PRODUCT

- a) There are two approved Std. Construction Details for blow-off assemblies - one for four-inch and larger pipe, the second for two-inch pipe.
- b) The Contractor shall furnish all parts for the complete assembly, including but not necessarily limited to gate valves, hydrant adapters, meter boxes, valve boxes, caps or plugs on the water main, a cap on the hydrant adapter, one MJ restraining device or MJ adapter for the cap or plug on the main and all related appurtenances.
- c) The outlet shall have 2-1/2-inch fire hydrant threads and a cap.
- d) Blow-Off Assembly for 4-Inch and Larger Pipe
 - i) Blow-off assembly shall connect to the end of the existing pipe through a tapped plug or cap. A two-inch corporation shall be threaded into the tapped cap/plug. Two-inch HDPE tube shall run from the two-inch corporation to a two-inch gate valve.
 - ii) The gate valve shall have a standard operating nut and have a standard valve box, brought to grade in conformance with the appropriate standard detail.
 - iii) Two-inch HDPE tubing shall run from the gate valve and terminate in 2-1/2-inch NST by 2-inch MIP brass hydrant adapter. The adapter shall have a threaded cap and shall be placed in a #37 meter box, set to grade.
- e) Blow-Off Assembly for 2-Inch Pipe
 - i) A two-inch gate valve shall be installed on the two-inch pipe.
 - ii) The gate valve shall have a standard operating nut and have a standard valve box, brought to grade, in conformance with the appropriate standard detail.
 - iii) Two-inch HDPE tubing shall run from the gate valve and terminate in 2-1/2-inch NST by 2-inch MIP brass hydrant adapter. The adapter shall have a threaded cap and shall be placed in a #37 meter box, set to grade.

3. QUALITY CONTROL AND TESTING

None specified. The installation shall conform to the appropriate Standard Detail.

4. MANUFACTURER

None specified. The installation shall conform to the appropriate Standard Detail.

W-100 AIR RELEASE VALVE

1. GENERAL

This section includes all air release valves to be owned and maintained by the City of Tampa Water Department. Requirements of this section apply to all air release valves unless exceptions are shown or stated on the plans or specific provisions.

2. PRODUCT

- a) The air release valve shall be of the float operated, compound leverage type, and be capable of automatically releasing accumulated air from a fluid system while that system is in operation and under pressure.
- b) To ensure drip-tight shut off, a buna-n orifice button shall be used to seal the valve discharge orifice. The orifice diameter must be sized for use within a given operation pressure range to insure maximum discharge capacity.
- c) Air release valves shall be provided with a vacuum check to prevent air from re-entering the system on negative pressure.
- d) All internal trim metal subject to wetting shall be stainless steel. The float shall be of stainless-steel construction and capable of withstanding a pressure of 1,000 p.s.i.
- e) Air release valves shall be installed inside of a Charles Industries fiber optic pedestal (Part No. CP210-NLP), in accordance with Department Details 2.14 (Automatic Air Release Valve) and 2.15 (Pedestal for Automatic Air Release Valve), having a buried, split, square base with a low-profile above-grade dome.

3. QUALITY CONTROL AND TESTING

When submitting for approval of air release valve not listed in Section 4, the Contractor shall include drawings and brochures that clearly indicate size, dimensions, weights, performance standards, etc. If this documentation is omitted, the air release valve may be rejected at the sole option of the City.

4. MANUFACTURER

Air release valves shall be Val-Matic Valve and Manufacturing Corp. "Model No. 38VC"; APCO "Model 200, with vacuum check", or approved equal. Pedestal shall be Charles Industries fiber optic pedestal (Part No. CP210-NLP).

W-110 LINE STOPS (4"-42")

1. GENERAL

Line stops shall be used to isolate sections of water mains in order to keep customers in service during water main tie-ins, water main repairs and to compensate for broken valves. The water mains shall remain under pressure during the installation and use.

Line stops shall be constructed of ductile iron or stainless steel (carbon steel is acceptable subject to Engineer approval). All line stop bodies shall be suitable for tapping cast iron, asbestos cement pipe (12" and smaller), ductile iron pipe, C-900 PVC pipe, and all pipe manufactured in accordance with ANSI A21 Standard, AWWA, and these specifications. Line stops on asbestos cement pipe, on pipe greater than 8" and on pipe with taps the same size shall be mechanical joint.

Line stops (steel/"O-ring" type) shall be constructed of high strength steel and shall be manufactured in accordance with ASTM A285. Line stops shall be suitable for tapping ductile iron pipe, C-900 PVC pipe, and all pipe manufactured in accordance with ANSI A21 Standards, AWWA, and these specifications.

2. PRODUCT

- a) Line stop fitting shall be full encirclement, pressure retention type split tee. It shall consist of two segments – an upper flange saddle plate and a lower saddle plate. All bodies shall have a 3/4" NPT test plug to verify all seals are secure prior to tapping. Cover plate gasket shall be EPDM. Completion plug O-ring shall be EPDM. Gasket shall

be molded from elastomer compounds that resist compression setting and are compatible with water in the 32 to 120 deg. F temperature range.

- b) Line stop sleeve shall have a full-circle rubber gasket and a flanged outlet for bolting to the line stop tapping valve. Sealing may be accomplished by either split end gaskets and mechanical joint ends or a single rubber gasket around the tap opening.
- c) Nuts-and-bolts shall be stainless steel.
- d) Outlet flange shall be ductile iron, stainless steel, or machined from a 150 lb. forged steel flange (ASTM A181 or A105) or from pressure vessel quality steel plate (ASTM A285, Grade C), be flat-faced and drilled per ANSI B16.5

3. QUALITY CONTROL

- a) Catalogs and manufacturer data shall be provided as required by the Engineer. The catalogs and maintenance data shall contain sufficient detail to serve as a guide in the line stop installation and the ordering of repair parts.
- b) The Water Department may request samples of proposed line stops. Samples shall be supplied and/or returned to the Contractor at the Contractor's expense.
- c) Failure to submit samples within 10 calendar days after the date of a written request shall result in rejection of that item.
- d) The sleeves shall be rated at 150 psi hydrostatic with a test pressure of 200 psi. And maintain zero leakage at all times.

4. MANUFACTURER

Line stops shall be domestically assembled equivalent to or better than Advanced Valve Technologies EZ Valve II, Hydra-Stop, JCM 440 Line Stop, or approved equal.

W-120 CASING SPACERS

1. GENERAL

Casing spacer sleeves shall be used to cradle carrier pipe through casing pipe.

2. PRODUCT

Casing spacer sleeves provided shall be either:

- a) Two-piece, 12-gauge stainless steel strap which is heat fused PVC coated. Sleeve runners shall be an ultra-high molecular weight polymer with high resistance to abrasion and sliding wear. Runners shall be 2-inch or 2-½ inch in height. Or,
- b) Projection type spacers composed of a single-piece HDPE strap providing constant projections around the entire circumference of the carrier pipe. The minimum number of projections to be provided around the circumference

shall total the number of diameter inches of the carrier pipe. Manufacturer-provided double-backed tape shall be used to fasten the HDPE casing spacer strap tightly to the carrier pipe so that the spacers do not move during installation. Selection of spacer type and installation shall be in accordance with manufacturer's installation guidelines and recommendations.

- c) Projection type spacers shall be ISO 9002 certified for strength and quality.

3. QUALITY CONTROL AND TESTING

When submitting for approval of a casing spacer not listed in Section 4, include manufacturer drawings/brochures that clearly indicate size, dimensions, weights, performance standards, etc. If this documentation is omitted, the casing spacer sleeves may be rejected at the sole option of the City.

4. MANUFACTURER

Casing spacer sleeves shall be Raci Spacers North America Inc "RACI Projection-type HDPE Casing Spacer", Cascade Manufacturing "CCS-450-1740" or "CCS-ER", PSI CG-2 series, or approved equal.

W-130 POLYETHYLENE ENCASEMENT

1. GENERAL

Polyethylene encasement shall conform to the requirements of ANSI/AWWA C-105/A21.5 Method A and shall be 8-mil thick. Polyethylene encasement shall be installed on all buried ductile iron pipe, fittings, valves, and appurtenances where shown on the drawings or as directed by the Water Department as dictated by field conditions. It shall be blue in color.

2. PRODUCT

The raw material used to manufacture polyethylene encasement shall be Type 1, Class A Grade E-1 in accordance with ASTM D-1248

The polyethylene encasement shall meet the following test requirements:

- Tensile Strength → 1200 psi minimum
- Elongation → 300% minimum
- Dielectric Strength → 800 V/Mil thickness, minimum
- Thickness → 0.008" (8-mils minimum nominal, with minus tolerance < 10% of nominal)
- Melt Index → 0.4 maximum

3. QUALITY CONTROL AND TESTING

When submitting for approval polyethylene not listed in Section 4, manufacturer shall include drawings and brochures that clearly indicate size, dimensions, weights, performance standards, etc. If this documentation is omitted, the polyethylene may be rejected at the sole option of the City.

4. MANUFACTURER

All polyethylene encasement shall be domestically manufactured.

W-131 LOCATING (TRACER) WIRE & BOXES

1. GENERAL

All tracer wire installed shall be insulated, blue coated, solid UF (Underground Feeder per National Electric Code Article 339) copper tracer wires for water main location purposes by means of an electronic line tracer.

Curb stop boxes (“boxes”) shall be provided to house the ends of tracer wires installed along a pipe and shall be installed directly over the pipe the wire is tracing. Tracer wire ends shall terminate in the curb stop box such that they can be accessed and charged to facilitate locating the buried pipe. Boxes installed in roadways shall be suitable for installation in areas subject to heavy vehicle traffic loading (be H-20 rated) and shall have cast iron rims. Boxes installed out of roadway or sidewalk shall be installed within reinforced concrete pads poured around valve boxes per the Standard Details, or in a separate 12”x12” (min.) x 6” reinforced concrete pad.

2. PRODUCT

- a) Tracer wire for direct bury installations shall be approved insulated copper clad steel (CCS) wire. Wire insulation shall be minimum 30 mil high-density, high molecular weight polyethylene (HDPE) colored to meet the APWA color code standard for identification of buried utilities. Conductor must be at 21% minimum conductivity for locate purposes, and be able to withstand a minimum 450 lb. break load.
- b) Sizes (gauges) for direct bury pipe tracer wire shall be as follows:
 - i) 16-in. and larger ductile iron pipe: 10 AWG
 - ii) PVC pipe: 12 AWG
 - iii) Long-side meter service line (direct bury and directional drilled): 12 AWG
 - iv) Tracer wire for directional drilled or bored-in pipe shall be approved insulated **10 AWG** copper clad steel wire insulated with 45 mil, high-density, high molecular weight polyethylene (HDPE), and rated for direct burial use at 30 volts minimum. Conductor must be at 21% minimum conductivity for locate purposes and be able to withstand a minimum 1150 lb. break load.
 - v) Tracer wire for Pipe Bursting shall be approved insulated copper clad steel wire, insulated with a 50 mil, high-density, high molecular weight polyethylene (HDPE) insulation, and rated for direct burial use at 30 volts minimum. Conductor must be at 21% minimum conductivity for locate purposes and be able to withstand a minimum 4700 lb. break load.
 - vi) Wire splices shall be with wire connectors suitable for buried service (i.e., be corrosion and moisture-proof).

vii) Stop boxes shall include locking lids lettered with "WATER" and shall be blue in color. All stop boxes shall be manufactured of high impact ABS plastic; cast iron roadway rims shall exceed ASTM A-48 Class 30. All stop boxes shall consist of a telescoping top and bottom section, with flared or square bottom to prevent settling or pull out of the box.

3. MANUFACTURER

Manufacturer shall be as indicated below or approved equal.

a) Tracer wire shall be:

- i) for direct bury pipe: Copperhead High Strength Tracer Wire, or Pro-Trace High-Flex Copper-clad Steel (HF-CCS) PE45
- ii) for directional drilled pipe: Copperhead SoloShot™ extra-high-strength copper-clad steel (EHS-CCS)
- iii) for pipe bursting: Copperhead Industries SoloShot™ *Xtreme*, 7x7 stranded Copper Clad Steel

b) Wire splices for tracer wire shall be: DBR Kit (by 3M), Snakebite (by Copperhead Industries)

c) Tracer wire boxes shall be: Bingham & Taylor Cathodic Protection Test Boxes (model P200NFG for non-roadway applications, P4HHD for roadway applications)

W-140 ASPHALTIC CONCRETE

1. GENERAL

Follow the latest FDOT standards Road and Bridge Construction for all asphaltic concrete including but not limited to pay items 9205 & 9207.

2. QUALITY CONTROL AND TESTING

The Contractor will be responsible for providing copies of all necessary plant production tests. The Contractor will be responsible for retesting of any failed sections. The contractor is responsible for all materials testing in section W-171.

W-141 BASE MATERIAL

1. GENERAL

Follow the latest FDOT standards Road and Bridge Construction for all base material.

2. QUALITY CONTROL AND TESTING

The Contractor will be responsible for retesting of any failed sections. The contractor is responsible for all materials testing in section W-171.

W-150 CONCRETE

1. GENERAL

Follow the latest FDOT standards Road and Bridge Construction referencing section 346 for sidewalk, curb and gutter, driveways, and any other associated flat work.

2. QUALITY CONTROL AND TESTING

The Contractor will be responsible for retesting of any failed sections. The contractor is responsible for all materials testing in section W-171.

W-160 ROOT PRUNING

1. GENERAL

The Contractor shall make provisions for tree protection to the satisfaction of the Engineer prior to any excavation. All applicable site inspections by the Planning and Development Department, and permits, shall be obtained prior to commencing work.

The Contractor shall provide root pruning services as directed by the Engineer.

2. PERFORMANCE OF WORK

All root pruning shall be performed by a qualified, licensed tree professional as approved by the Engineer.

All roots designated to be removed shall be severed leaving a smooth, uniform section at the remaining root end to prevent root damage.

Root pruning shall be performed with a chain saw, Dosco root pruner, or equal, as approved by the Engineer.

Root pruning shall not occur within 6 feet of the base of the tree without guidance from Planning and Development Department staff, and no excavation shall occur inside the circumference of the root-pruned area.

W-170 RESTORATION

1. GENERAL

- a) The various street surfaces disturbed, damaged, or destroyed during the performance of the work under this Contract shall be restored and maintained as shown, specified, and directed. Included in this classification are permanent pavement surfaces of all types, pavement bases, curb, curb and gutter, alleys, driveways, and sidewalks.
- b) Service boxes, manhole frames and covers, and similar structures not conforming to the new work shall be set to established grade at the Contractor's expense, and no separate payment will be made therefor.
- c) All portland cement and asphaltic concrete pavements shall be removed in rectangular sections with sawed vertical cuts, or to existing joints, or as directed by the Engineer. Asphaltic concrete pavements and concrete pavement shall be saw cut parallel perpendicular straight line or as directed by the Engineer. The edges shall be trimmed to which a roller may follow. Where reinforced concrete pavement is removed, one foot of existing reinforcement on each side of the excavation shall be left exposed and tied to the replaced reinforcing steel.

2. TEMPORARY RESTORATION

- a) Upon completion of backfilling, the street or sidewalk surface damaged or destroyed shall be promptly placed in condition for safe temporary use. Temporary work shall be maintained in a suitable and safe condition for traffic and pedestrians until the permanent pavement is laid, or until final acceptance of the work.
- b) Pavement surfaces shall be temporarily restored by placing thereon, to proper line, grade and transverse profile, a layer or layers of compacted base material, as specified, conforming to all requirements regarding configuration, thickness, and density as detailed in the Plans, specified, and directed by the Engineer.
- c) Curbs, where possible, shall be temporarily reset in place, as part of the work of temporary restoration of pavement.
- d) Damaged or destroyed sidewalks shall be temporarily restored, immediately upon placing of the backfill.
- e) The temporary pavement shall be maintained by the Contractor and all holes and depressions filled until the permanent pavement is placed.
- f) Crushed concrete or similar material placed in areas where the existing pavement is shell, limerock, crushed stone, or other similar material shall be classified as nonpermanent pavement, will not be measured for separate payment.
- g) Temporary sand and asphalt wearing courses placed on base on which a permanent pavement surface will be constructed shall be incidental to the permanent pavement base work, and no separate payment will be made therefor.
- h) Materials for temporary sidewalk surface shall be incidental to sidewalk replacement, and no separate payment will be made therefor.

3. REPLACEMENT OF CURB, CURB & GUTTER, SIDEWALK & DRIVEWAYS

- a) All permanent restoration of street curb or curb and gutter shall be of the same type and thickness as the curb or curb gutter which abuts. The grade of the restored curb and curb and gutter shall conform with the grade of the existing adjacent curb or curb and gutter.
- b) Except as otherwise specified herein or detailed in the Plans, all permanent restoration of driveways and sidewalks shall conform to the manner of construction as originally placed and to the lines and grades as given by the Engineer. No patching of concrete driveway areas will be allowed between joints or dummy joints.
- c) Where sidewalks are replaced, the replacement shall be the full width of the walk and minimum lengths shall be 60 inches. Restoration of adjacent lawn is incidental to sidewalk replacement, and no separate payment will be made therefor.

4. REPLACEMENT OF TRAFFIC MARKINGS & SIGNALIZATION LOOPS

- a) The Contractor shall furnish all labor, equipment and materials to replace, test and maintain all traffic markings (temporary and permanent) and signalization loops removed or damaged by pipeline construction and appurtenance work as shown on the Plans, specified and directed by the Engineer.
- b) The replacement of traffic markings (temporary and permanent), signalization loops and all appurtenant work shall be replaced by the Contractor in kind.

- c) It shall be the Contractor's responsibility to field verify before construction begins all markings and signalization loops to be replaced.
- d) All traffic markings and signalization loops shall conform to the Workmanship and Materials standards set forth in the latest edition of the Florida Department of Transportation Standard and Supplemental Specifications.
- e) Payment for the replacement of temporary and permanent traffic markings, signalization loops and all appurtenant work shall be included in the unit bid price for Permanent Pavement Surface Replacement, Asphaltic Concrete, or as part of the Lump Sum price and no separate payment shall be made therefor.

W-171 CITY MATERIALS TESTING FREQUENCY

1. GENERAL

- a) Contractor is responsible for all testing including costs.

2. TABLE

- a) Shows frequency by materials

| Item | Test | | Test Frequency |
|--|--|--|--|
| Embankment | Optimum Moisture/Maximum Dry Density of soil (proctor) as determined by AASHTO T180. | | Per Soil Type |
| | Density Test within Right-of-Way (R.O.W.). | 98% of Maximum Dry Density as determined by AASHTO T180 | One per 200' horizontally, in one-foot lifts (1) |
| | . Density Test Outside of R.O.W | 95% of Maximum Dry Density as determined by AASHTO T180. | One per 200' horizontally, in one-foot lifts (1) |
| | Gradation (Sieve Analysis) AASHTO T 27, T 11, ND T 89, ND T90. | | Per Soil Type |
| Utility Trench Backfill – over pipelines and around structures from R.O.W. line to R.O.W. line | Optimum Moisture/Maximum Dry Density of soil by AASHTO T180. | | Per Soil Type |
| | 98% of Maximum Dry Density (proctor). Soil mix by AASHTO T180. | | (1)(2) |
| Utility Trench Backfill – over | Optimum Moisture/Maximum Dry Density (proctor). Soil Mix by AASHTO T180. | | Per Material Type |

| | | | |
|---|--|------------------------------|---------------------------------|
| pipelines and around structures outside R.O.W. line | 95% of Maximum Dry Density as determined by AASHTO T180. | (1)(2) | |
| Stabilized Subgrade | Limerock Bearing Ratio (LBR) as per FM 5-515. | Per Soil Type | |
| | Minimum 40 LBR. | Per Material Type (3) | |
| | Minimum 20 LBR (For Soil Cement Only). | Per Material Type | |
| | Subgrade to be used under soil cement shall have a minimum 20 LBR. | Per Material Type | |
| | Moisture/Maximum Dry Density of soil (proctor). Proctor as per FM 5-515. | Per Material Type | |
| | 98% of Maximum Dry Density as determined by FM 5-515. No tolerance. Soil Cement - 97% of Maximum Dry Density as determined by AASHTO-T134. No tolerance | (3)(4) | |
| Base (Other than soil cement or crushed concrete) | Limerock Bearing Ratio (FM 5-515). Minimum LBR 100. | Per Material Type/Per Source | |
| | 98% of Maximum Dry Density as determined by FM 5-515. No tolerance. | (3)(4) | |
| Item | Test | Test Frequency | |
| Superpave Asphalt | Mix Design | One per FDOT Approved type | |
| | Temperature | (6) | |
| | Maximum Specific Gravity (FM 1-T209) | One per day. | |
| | Extraction/Gradation (FM5-563/FM 1-T030) | | |
| | Thickness. No core shall be less than the specified thickness. | | Three cores per production day. |
| | Straightedge (FM 5-509) | | (7) |
| | Bulk Specific Gravity (MF 1-T166) 90% of Lab Density for Local Roadways (Remove and Replace if not met); and | | (3) see Nuclear Density Testing |

| | 92% of Lab Density for Collectors and Arterials (Remove and Replace if not met). | | |
|-----------------------|--|------------|--|
| Item | Test | | Test Frequency |
| Soil Cement Base | | Mix Design | Per Material Type |
| | Moisture/Maximum Dry Density of soil (proctor) AASHTO T134 | | Per Material Type |
| | 97% of Maximum Dry Density as determined by AASHTO T134. No tolerance. | | (3)(4) |
| | Compressive Strength of Specimens | | One set of three per material type daily |
| | Cores Thickness Test | | (3) |
| Crushed Concrete Base | Gradation | | Per Type of Material/Source (5) |
| | Abrasion per FM 1-T096 | | Per Type of Material/Source |
| | Limerock Bearing Ratio (LBR) as per FM 5-515. Minimum LBR 150. | | Per Type of Material/Source |
| | 98% of Maximum Dry Density as determined by FM 5-515. No tolerance. | | (4) |
| Concrete | Temperature (ASTM C1064) | | One per set of cylinders |
| | | | |
| | Slump (ASTM C143) | | One per set of cylinders |
| | Air Content (ASTM C231 or C173 as applicable) | | One per set of cylinders |
| | Compressive Strength Cylinders (ASTM C31 and C39) | | One set of four (6x12) inch or one set of five (4x8) inch cylinders for 100 cubic yards or fraction thereof, per class of concrete. Tested as follows: 1 at 7 days, 2 at 28 days, and 1 as reserve tested 56 days is necessary. Three cylinders shall be tested at 28 days if 4x8 inch cylinders are used. |

1) Recommend testing methods: FM 1-T238, FM- T204, ASTM D6938, and ASTM D2937.

2) Tests shall be located no more than 200 feet apart. Tests shall be performed on each lift, except that tests shall not be further apart than one foot vertically. Field Densities shall be taken over all road crossings. Field Densities for Sanitary Lines shall be staggered to include results over service laterals. There shall be a minimum of one test series for each one foot of lift over pipeline between manholes. Tests around structures shall be spiraled in one-foot lifts. For all type pipe, fill to be compacted beneath the haunches using suitable tampers. For pipe less than 24 inches in diameter, backfill in appropriate lifts and test from the top of the pipe and every one foot vertically thereafter. For pipe 24 inches to 72 inches in diameter, backfill in appropriate lifts and test from the springline and every one-foot vertically thereafter. For pipe larger than 72 inches, tests shall begin one foot above the base of the trench.

- 3) *Tests for base material shall be located no more than 200 feet apart. Tests for asphalt pavement shall be located no more than 500 feet apart. There shall be no less than one test per street. No core shall be less than specified minimum thickness. Nuclear Density Tests may be acceptable if approved by the City Engineer/Engineer of Record.*
- 4) *Testing for the subgrade and base compaction shall be located no more 200 feet apart and shall be staggered to the left, right, and on the centerline of the roadway. The City Engineer may reserve the right to sample and test any material utilized in the construction of the roadway. Testing shall be in accordance with the Testing Schedule and applicable City of Tampa Standard Specifications and latest FDOT Standard Specifications for Road and Bridge Construction. Inspection of the subgrade and base shall be conducted by the City Inspector, and shall be approved by the City Engineer/Engineer of Record prior to the base and asphalt construction respectively. Note: The City reserves the right to sample and test any material during construction.*
- 5) *Materials requirements as per latest FDOT Standard Specifications for Road and Bridge Construction*
- 6) *Continuous for the five first loads if the temperature is within the master range take a temperature measurement every five (5) loads thereafter or as directed by the Engineer.*
- 7) *For City local roads the straightedge test will be required only if requested by the City Engineer/Engineer of Record.*

CITY OF TAMPA WATER DEPARTMENT STANDARD DETAILS

| DETAIL NO. | DETAIL TITLE |
|------------|--|
| 2.01A | TRENCHING, BEDDING AND BACKFILL DETAIL FOR NON-PERVIOUS (PAVED) AREAS |
| 2.01B | STANDARD DETAIL FOR RESTORATION WITHIN COT ROADWAY – FLEXIBLE PAVEMENT |
| 2.02 | TRENCHING, BEDDING AND BACKFILL DETAIL FOR PERVIOUS (NON-PAVED) AREAS |
| 2.03 | JACKING & BORING FOR PAVEMENT CROSSING |
| 2.04 | JACKING & BORING FOR RAILROAD CROSSINGS |
| 2.05 | POLYETHYLENE ENCASEMENT INSTALLATION DETAIL |
| 2.06 | REINFORCED CONCRETE SHOCK PAD (FOR COVER LESS THAN 2.5') |
| 2.11 | RESTRAINED JOINT STANDARD FOR BENDS, PLUGS, CAPS, AND VALVES |
| 2.12A | RESTRAINED JOINT STANDARD FOR TEES AND REDUCERS |
| 2.12B | DEADMAN THRUST BLOCK |
| 2.13A | TAPPED CONNECTION FROM DI, CI, OR PVC PIPE TO <4" WATER MAINS |
| 2.14A | AUTOMATIC AIR RELEASE VALVE |
| 2.14B | AUTOMATIC AIR RELEASE VALVE/AIR VACUUM VALVE |
| 2.17A | BLOW-OFF VALVE ASSEMBLY FOR ≥ 4" MAINS W/DI, CI, OR PVC PIPE |
| 2.17C | BLOW-OFF VALVE ASSEMBLY FOR 4" & 6" MAINS W/DI, CI, OR PVC PIPE – LATERAL CONNECTION |
| 2.18A | TEMPORARY SAMPLE TAP INSTALLATION W/DI, CI, OR PVC PIPE |
| 2.18B | TEMPORARY SAMPLE TAP INSTALLATION W/HDPE PIPE |
| 2.19A | TEMPORARY SAMPLE TAP INSTALLATION FOR END OF LINE W/DI, CI, OR PVC PIPE |
| 2.20 | DUCTILE IRON PIPE IDENTIFICATION DETAIL |
| 3.01 | VALVE INSTALLATION W/VALVE BOX & PAD FOR DI OR CI PIPE |
| 3.02 | VALVE INSTALLATION W/VALVE BOX & PAD FOR PLASTIC PIPE WITH DOUBLE COPPER TRACER WIRE ON PIPE |
| 3.03 | BUTTERFLY/PLUG (≥16") VALVE INSTALLATION W/VALVE BOX & PAD |
| 3.04 | VALVE BOX, SLIP TYPE |
| 3.05 | VALVE BOX (V. BOX) ADJUSTMENTS FOR GRADE CHANGE |
| 4.01 | FIRE HYDRANT INSTALLATION |
| 4.02 | FIRE HYDRANT METHODS OF INSTALLATION |
| 5.01A | TAPPING DETAIL FOR 3/4", 1", 1-1/2", & 2" W/DI, CI, OR PVC PIPE |
| 5.02 | SINGLE METER SET DETAIL 3/4", 1", 1-1/2", 2" |
| 5.04A | SINGLE & DUAL METERED SERVICE – SHORT SIDE 3/4", 1", 1-1/2" & 2" |
| 5.05A | SINGLE & DUAL METERED SERVICE – LONG SIDE 3/4", 1", 1-1/2" & 2" |
| 5.10 | 3/4" OR 1" SINGLE SERVICE HDPE METER BOX |
| 5.11 | 3/4" OR 1" DUAL SERVICE HDPE METER BOX |
| 5.12 | 1-1/2" & 2" SINGLE SERVICE HDPE METER BOX |
| 6.01A | ABOVE GROUND LARGE METER ASSEMBLY (3" OR LARGER) |
| 6.03 | ABOVE GROUND PIPE SUPPORTS |
| 6.04 | METER IN VAULT |
| 6.07 | VAULT CONSTRUCTION DETAIL FOR METER/DDCVA |
| 6.08 | VAULT CONCRETE SLAB DETAIL FOR METER/DDCVA |
| 6.09 | METER W/STRAINERS IN ABOVE GROUND VAULT |
| 6.12 | ABOVE GROUND VAULT CROSS SECTION |
| 6.13 | 2" BY-PASS LINE |
| 7.01R | VALVE INSTALLATION W/VALVE BOX & PAD FOR DR OR CI PIPE - RECLAIMED |
| 7.02R | 1-1/2" & 2" SINGLE SERVICE HDPE METER BOX – RECLAIMED |
| 8.01 | HDPE PIPE TO MJ FITTING TRANSITION |
| 8.02 | HDPE PIPE TO D.I.P./PVCP SPIGOT-TO-SPIGOT TRANSITION |
| 8.03 | HDPE PIPE TO DI MJ FITTING TRANSITION (4" OR LARGER) |

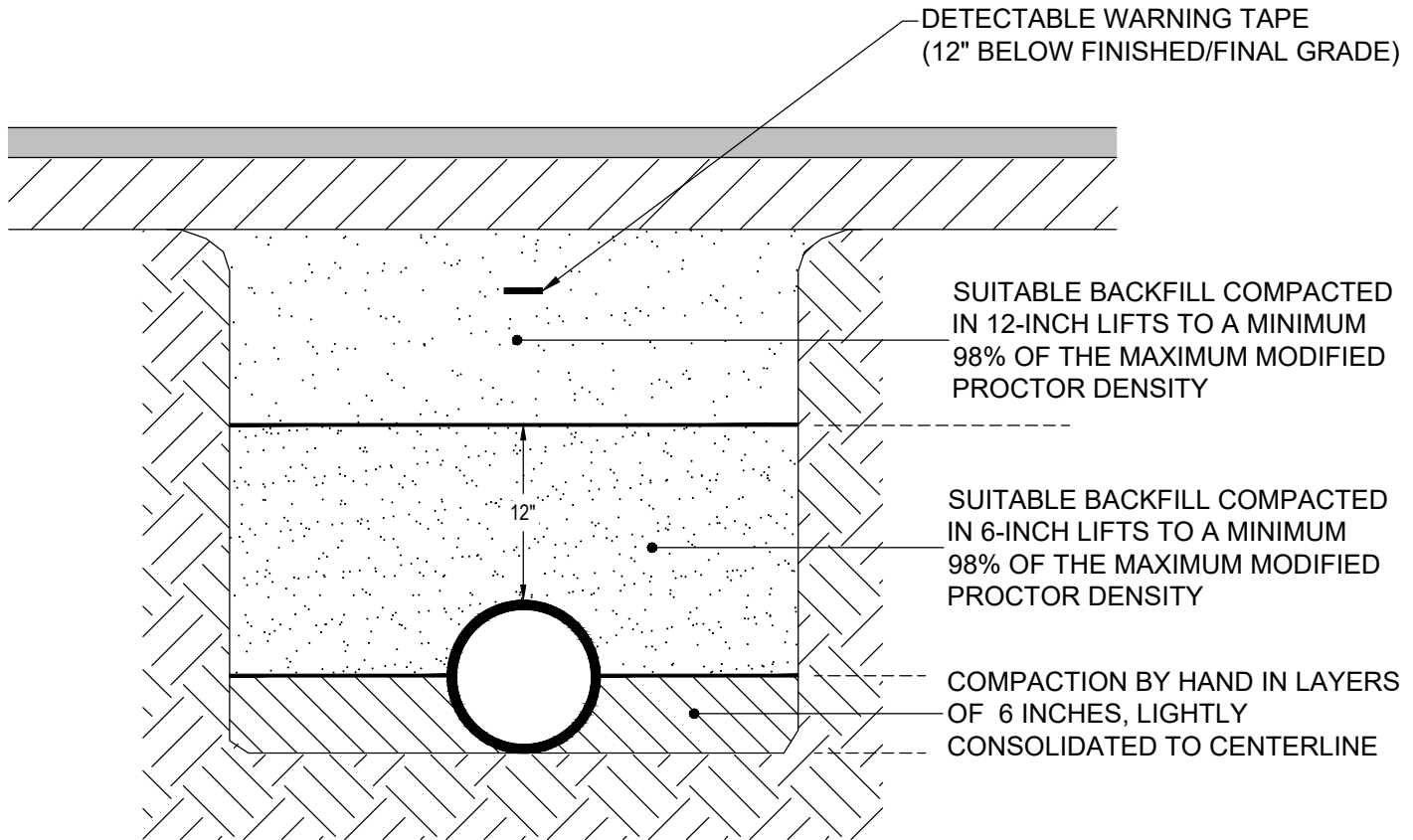

NOTES:

1. TRENCH IS DEFINED AS A FLAT-BOTTOM TRENCH. LIGHTLY CONSOLIDATE BACKFILL TO CENTERLINE OF PIPE.
2. THIS STANDARD SHALL BE UTILIZED IN THE ABSENCE OF SPECIFIC STANDARDS. THE STANDARD OF THE AGENCY CONTROLLING THE RIGHT-OF-WAY SHALL GOVERN UNLESS OTHERWISE DIRECTED BY CITY ENGINEER.
3. SUITABLE BACKFILL SHALL BE DEFINED AS MATERIAL FREE FROM CINDERS, ASHES, REFUSE, CLAY, ORGANIC MATTER, BOULDERS, ROCKS OR STONES, OR OTHER MATERIAL THAT IN THE OPINION OF THE CITY ENGINEER IS UNSUITABLE.
4. NON-PERVIOUS AREAS SHALL MEAN ANY CONCRETE OR ASPHALT CURB, SIDEWALK, TRAIL, DRIVEWAY, OR ROADWAY.

| | | | |
|--|-----------------------------------|--|--------------|
|  | <p>LAST REVISION MAY 2021</p> | <p>TRENCHING, BEDDING AND BACKFILL DETAIL FOR NON-PERVIOUS (PAVED) AREAS</p> | <p>2.01A</p> |
|--|-----------------------------------|--|--------------|

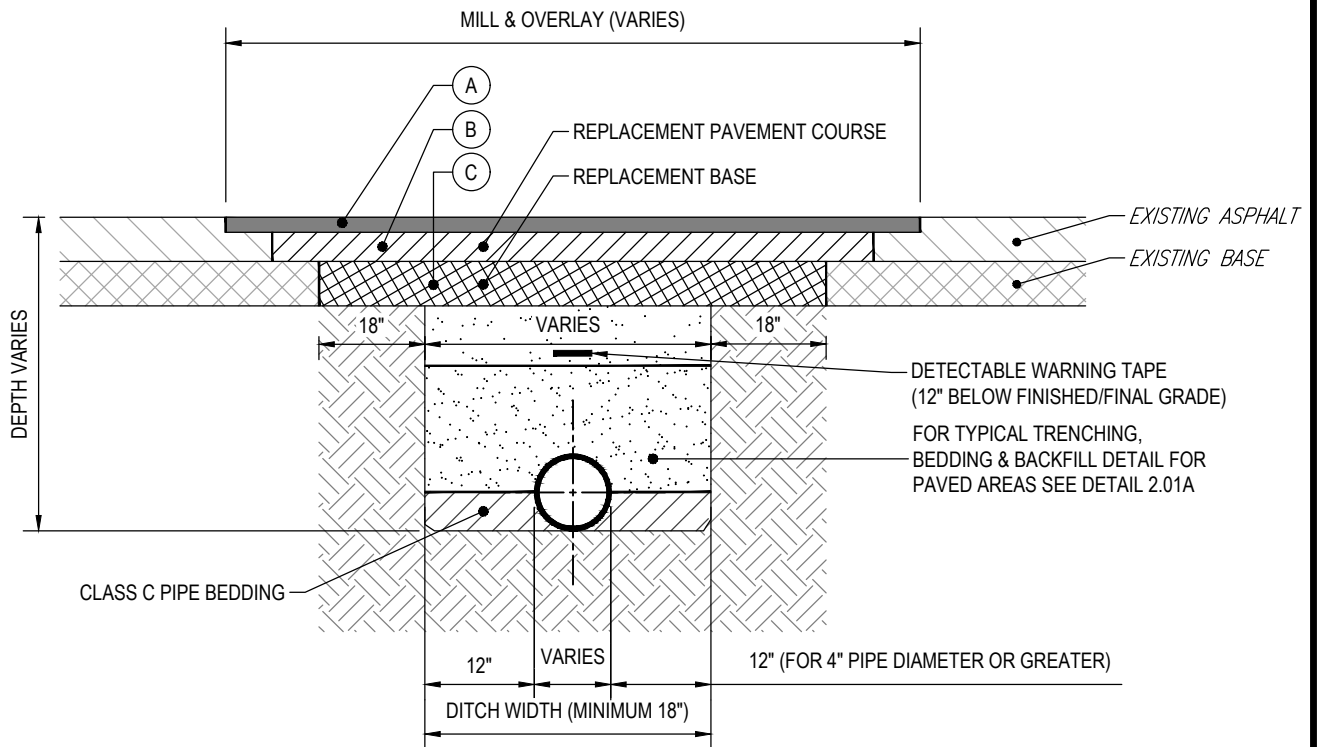

PAVEMENT LAYERS (SEE SPECIFICATIONS)

- A. TYPE SP 9.5 ASPHALT (1") MILL & OVERLAY
- B. TYPE SP 9.5 OR SP 12.5 ASPHALT (1" FOR CLASS I, 2" FOR CLASS II)
- C. CRUSHED CONCRETE BASE (8" FOR CLASS I, 12" FOR CLASS II)

NOTES:

1. PAVEMENT SHALL BE MECHANICALLY SAWED.
2. CLASS I = RESIDENTIAL ROAD AND CLASS II = COLLECTOR/ARTERIAL ROAD.
3. THE MILL AND OVERLAY COURSE (A) SHALL BE 1" THICK AND FDOT TYPE SP 9.5 ASPHALT SHALL BE USED. LIFT TO BE ¾" MIN. AND 1½" MAX. FOR CLASS I AND CLASS II ROADS.
WHEN TRENCH IS PERPENDICULAR TO THE ROAD: THE WIDTH OF THE REPLACEMENT BASE LIMIT ± 10' ON EACH SIDE
WHEN TRENCH IS PARALLEL TO THE ROAD: THE FULL WIDTH OF THE ROAD (CURB TO CURB)
4. THE REPLACEMENT PAVEMENT COURSE (B) SHALL EXTEND ± 12" ON EACH SIDE OF THE REPLACEMENT BASE LIMIT AND BE FDOT TYPE SP 9.5 OR SP 12.5 WITH A THICKNESS EQUAL TO THE EXISTING OR AS INDICATED, WHICHEVER IS GREATER. LIFT TO BE ¾" MIN. AND 1½" MAX. FOR SP 9.5 AND 1¼" MIN. TO 3" MAX. FOR SP 12.5.
5. THE REPLACEMENT BASE (C) MATERIALS SHALL BE EITHER OF THE SAME TYPE AND COMPOSITION AS THE MATERIALS REMOVED OR OF EQUAL OR GREATER STRUCTURAL ADEQUACY. BASE SHALL BE INSTALLED TO A THICKNESS OF THE EXISTING BASE OR AS INDICATED, WHICHEVER IS GREATER. BASE SHALL EXTEND 18" IN EACH SIDE OF THE TRENCH LIMIT. CRUSHED CONCRETE BASE SHALL FOLLOW FDOT STANDARD SPECIFICATIONS FOR RECYCLED CONCRETE AGGREGATES, LATEST EDITION. LAYER COEFFICIENT (SN) SHALL BE 0.18 WITH LIMEROCK BEARING RATIO (LBR) 150 OR GREATER. GRADATION AND SIZE REQUIREMENTS SHALL CONFORM TO FDOT LATEST SPECIFICATIONS.

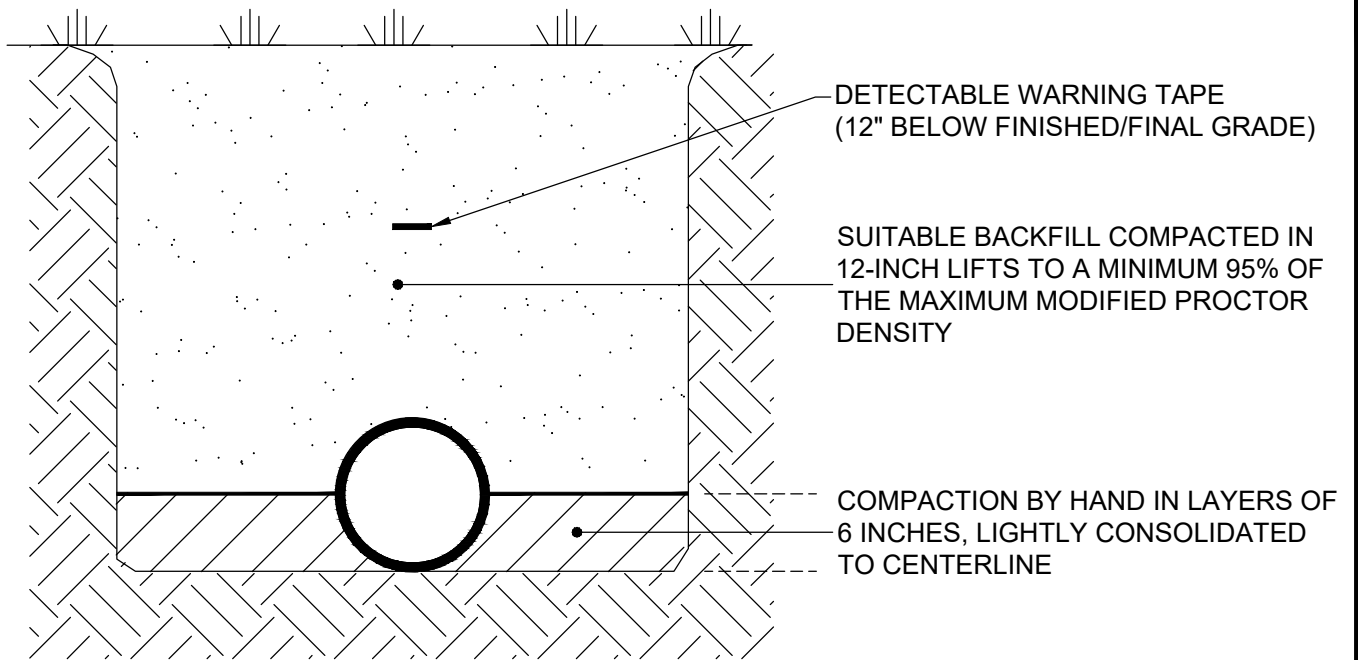

NOTES:

1. TRENCH IS DEFINED AS A FLAT-BOTTOM TRENCH. LIGHTLY CONSOLIDATE BACKFILL TO CENTERLINE OF PIPE.
2. THIS STANDARD SHALL BE UTILIZED IN THE ABSENCE OF SPECIFIC STANDARDS. THE STANDARD OF THE AGENCY CONTROLLING THE RIGHT-OF-WAY SHALL GOVERN UNLESS OTHERWISE DIRECTED BY CITY ENGINEER.
3. SUITABLE BACKFILL SHALL BE DEFINED AS MATERIAL FREE FROM CINDERS, ASHES, REFUSE, CLAY, ORGANIC MATTER, BOULDERS, ROCKS OR STONES, OR OTHER MATERIAL THAT IN THE OPINION OF THE CITY ENGINEER IS UNSUITABLE.
4. NON-PAVED AREA IS A PERVIOUS AREA. IF ANY PART OF THE TRENCH IS WITHIN A CONCRETE OR ASPHALT CURB, SIDEWALK, DRIVEWAY, OR ROADWAY, THEN STANDARD DETAIL 2.01 APPLIES.

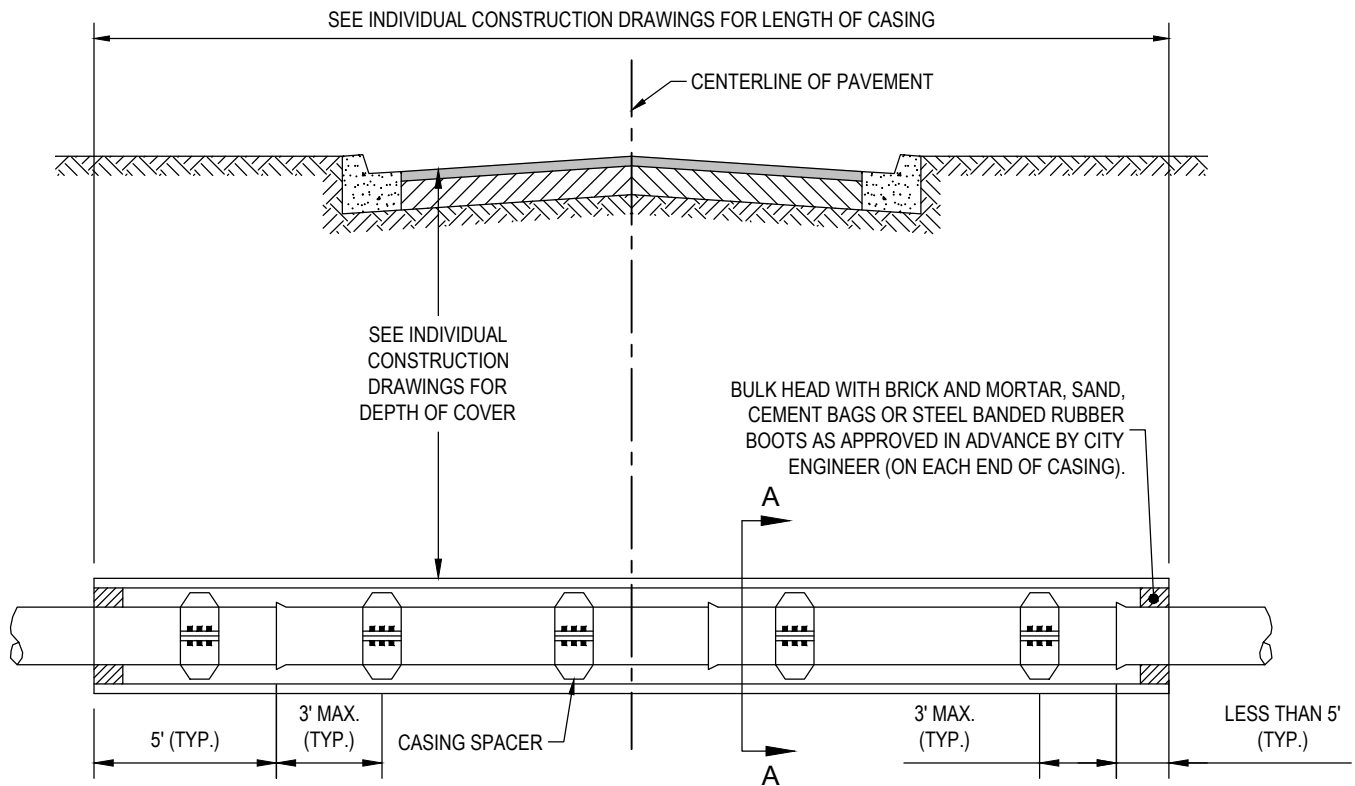

SEE INDIVIDUAL CONSTRUCTION DRAWINGS FOR LENGTH OF CASING

SEE INDIVIDUAL CONSTRUCTION DRAWINGS FOR DEPTH OF COVER

BULK HEAD WITH BRICK AND MORTAR, SAND, CEMENT BAGS OR STEEL BANDED RUBBER BOOTS AS APPROVED IN ADVANCE BY CITY ENGINEER (ON EACH END OF CASING).

STEEL CASING - DIAMETER AS SHOWN IN TABLE OR AS DIRECTED IN PLANS. (ASTM A139 GRADE B)

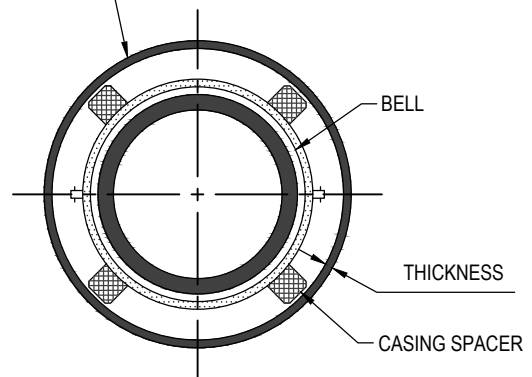

SECTION A - A

| D.I.P. CARRIER PIPE (P.O.) NOMINAL DIAMETER (INCHES) | CASING O.D. (INCHES) | THICKNESS |
|--|----------------------|---------------|
| 2 | 4 | 1/4" (.250) |
| 4 | 12 | 1/4" (.250) |
| 6 | 14 | 9/32" (.281) |
| 8 | 16 | 9/32" (.281) |
| 12 | 20 | 11/32" (.344) |
| 16 | 24 | 13/32" (.406) |
| 20 | 30 | 15/32" (.469) |
| 24 | 36 | 17/32" (.531) |
| 30 | 42 | 9/16" (.563) |
| 36 | 48 | 9/16" (.563) |
| 42 | 54 | 9/16" (.563) |

NOTES:

1. PIPELINES WITH BENDS LESS THAN 20' FROM CASING ENTRANCE SHALL BE SECURED BY BOTH MECHANICAL RESTRAINTS AND THRUST BLOCKS.
2. CASING PIPE SIZES LISTED ARE FOR PUSH-ON JOINT CARRIER PIPE ONLY.
3. TWO SPACERS PER JOINT MINIMUM SPACED AS SHOWN OR AS DIRECTED BY CITY ENGINEER.

SEE INDIVIDUAL CONSTRUCTION DRAWINGS FOR LENGTH OF CASING

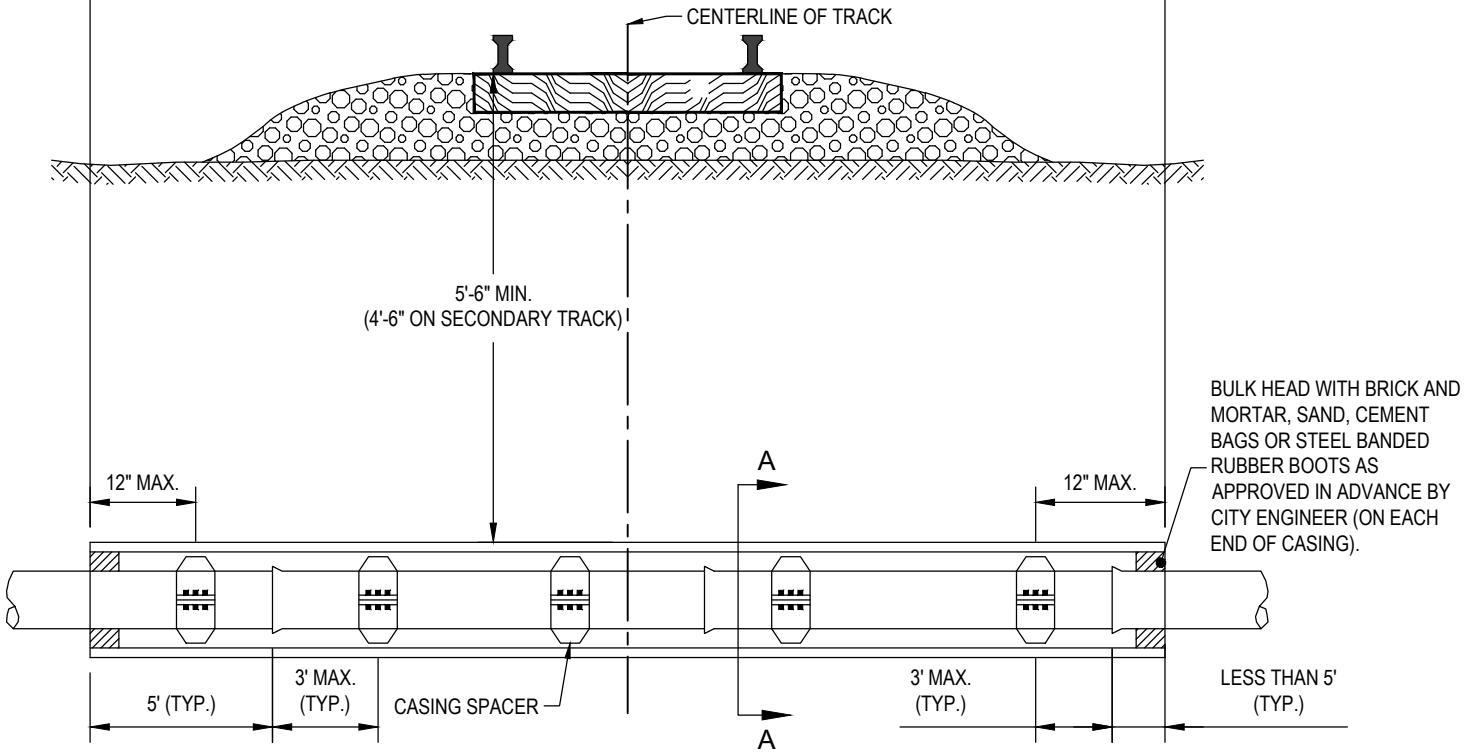

STEEL CASING - DIAMETER AS SHOWN
IN TABLE OR AS DIRECTED IN PLANS.
(ASTM A139 GRADE B)

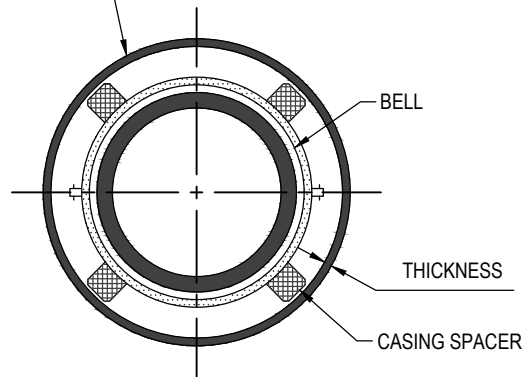

SECTION A - A

| D.I.P. CARRIER PIPE (P.O.) NOMINAL DIAMETER (INCHES) | CASING O.D. (INCHES) | THICKNESS |
|--|-------------------------|---------------|
| 2 | 4 | 1/4" (.250) |
| 4 | 12 | 1/4" (.250) |
| 6 | 14 | 9/32" (.281) |
| 8 | 16 | 9/32" (.281) |
| 12 | 20 | 11/32" (.344) |
| 16 | 24 | 13/32" (.406) |
| 20 | 30 | 15/32" (.469) |
| 24 | 36 | 17/32" (.531) |
| 30 | 42 | 5/8" (.625) |
| 36 | 48 | 11/16" (.688) |
| 42 | 54 | 25/32" (.781) |

NOTES:

1. PIPELINES WITH BENDS LESS THAN 20' FROM CASING ENTRANCE SHALL BE SECURED BY BOTH MECHANICAL RESTRAINTS AND THRUST BLOCKS.
2. CASING PIPE SIZES LISTED ARE FOR PUSH-ON JOINT CARRIER PIPE ONLY.
3. TWO SPACERS PER JOINT MINIMUM SPACED AS SHOWN OR AS DIRECTED BY CITY ENGINEER.

METHOD A

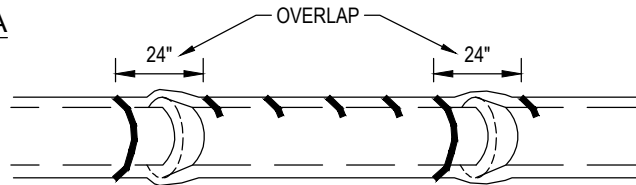

POLYETHYLENE TUBE IS CUT INTO LENGTHS APPROXIMATELY TWO FEET LONGER THAN THE PIPE SECTION AND PLACED AROUND IT. AFTER THE PIPE JOINT IS ASSEMBLED, THE POLYETHYLENE TUBE IS MADE TO OVERLAP THE JOINT AND THE OVERLAP SECURED IN PLACE. SINCE THE TUBE IS CONSIDERABLY LARGER THAN THE BARREL OF PIPE, IT IS MADE TO FIT SNUGLY BY FOLDING OVER AT THE TOP AND SECURING WITH TAPE EVERY 24" ALONG THE PIPE SECTION.

METHOD B

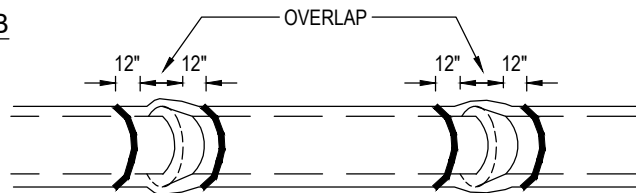

POLYETHYLENE TUBE IS CUT ONE FOOT SHORTER THAN THE LENGTH OF THE PIPE SECTION. AFTER PLACEMENT OF THE PIPE, IT IS FOLDED AND SECURED SNUGLY OVERALL. A THREE FOOT LENGTH OF POLYETHYLENE TUBE PLACED OVER THE END OF THE PRECEEDING SECTION IS THEN PULLED IN PLACE OVER THE JOINT AFTER ASSEMBLY AND SECURED.

METHOD C

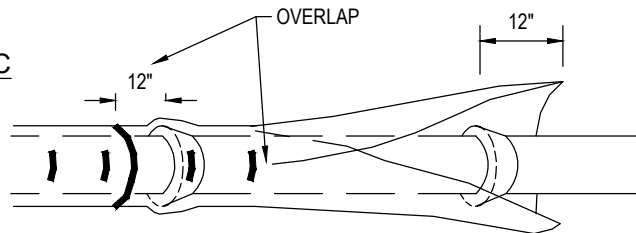

POLYETHYLENE SHEET IS CUT TO A LENGTH TWO FEET LONGER THAN THE PIPE SECTION. THE SHEET IS WRAPPED AROUND THE PIPE SO THAT IT OVERLAPS CIRCUMFERENTIALLY OVER THE TOP QUADRANT OF THE PIPE, THEN SECURED. AFTER JOINT ASSEMBLY, THE SURPLUS LENGTH OF POLYETHYLENE FILM IS SECURED AROUND THE JOINT, PROVIDING AN OVERLAP OF EACH JOINT. TAPE AT EACH JOINT AND AT 3' INTERVALS IN BETWEEN.

NOTES:

1. USE BLUE POLYETHYLENE FILM AND TAPE ONLY.
2. POLYETHYLENE FILM SHALL BE A MINIMUM OF 8 MIL. THICKNESS.
3. SPIRAL WRAP NOT REQUIRED WITH POLYWRAP.

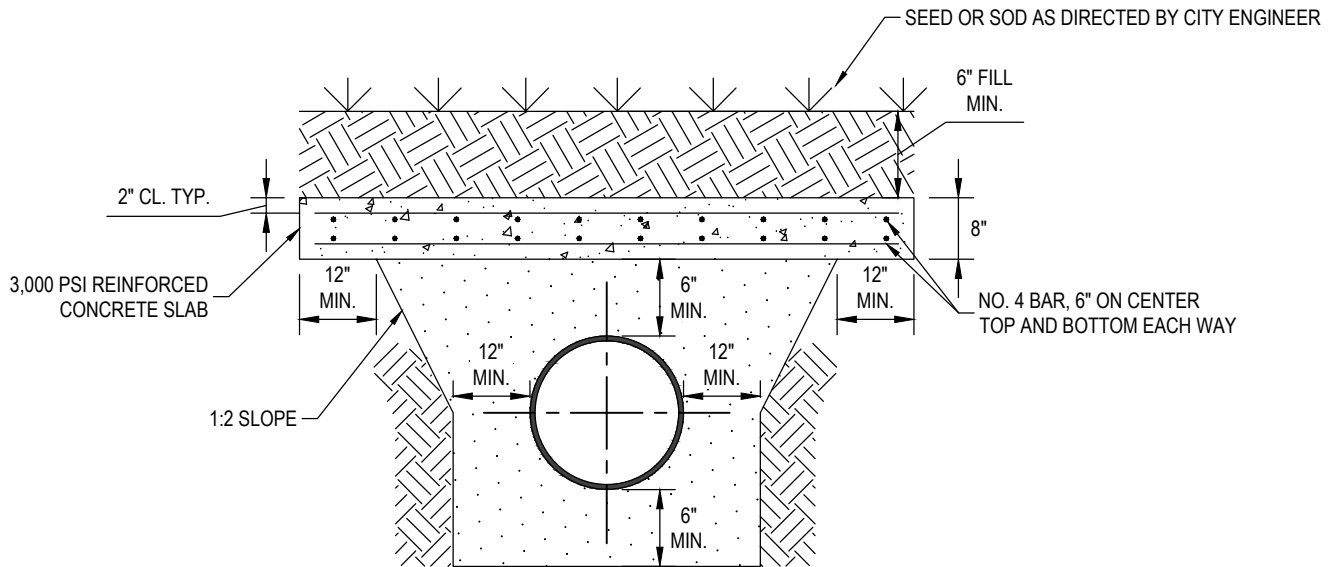

GRASSED SECTION

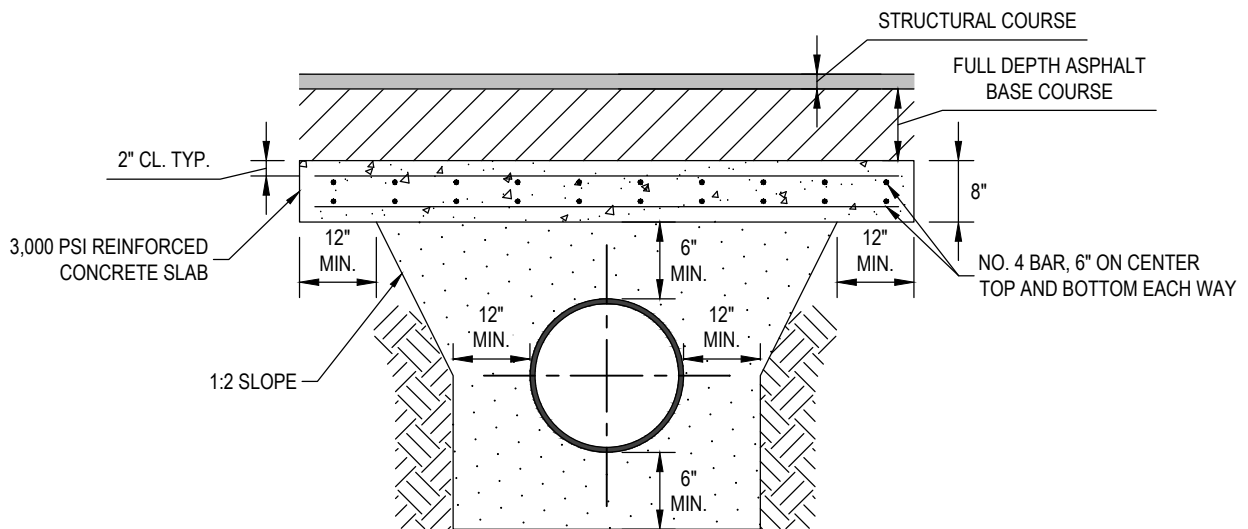

ROADWAY SECTION

NOTES:

1. STRUCTURAL COURSE AND BASE COURSE REQUIREMENT SHALL BE ESTABLISHED BY THE AGENCY HAVING JURISDICTION.
2. SHOCK PADS FOR MAINS TOO SHALLOW FOR THE ABOVE CONFIGURATION SHALL BE DESIGNED ON A CASE-BY-CASE BASIS.

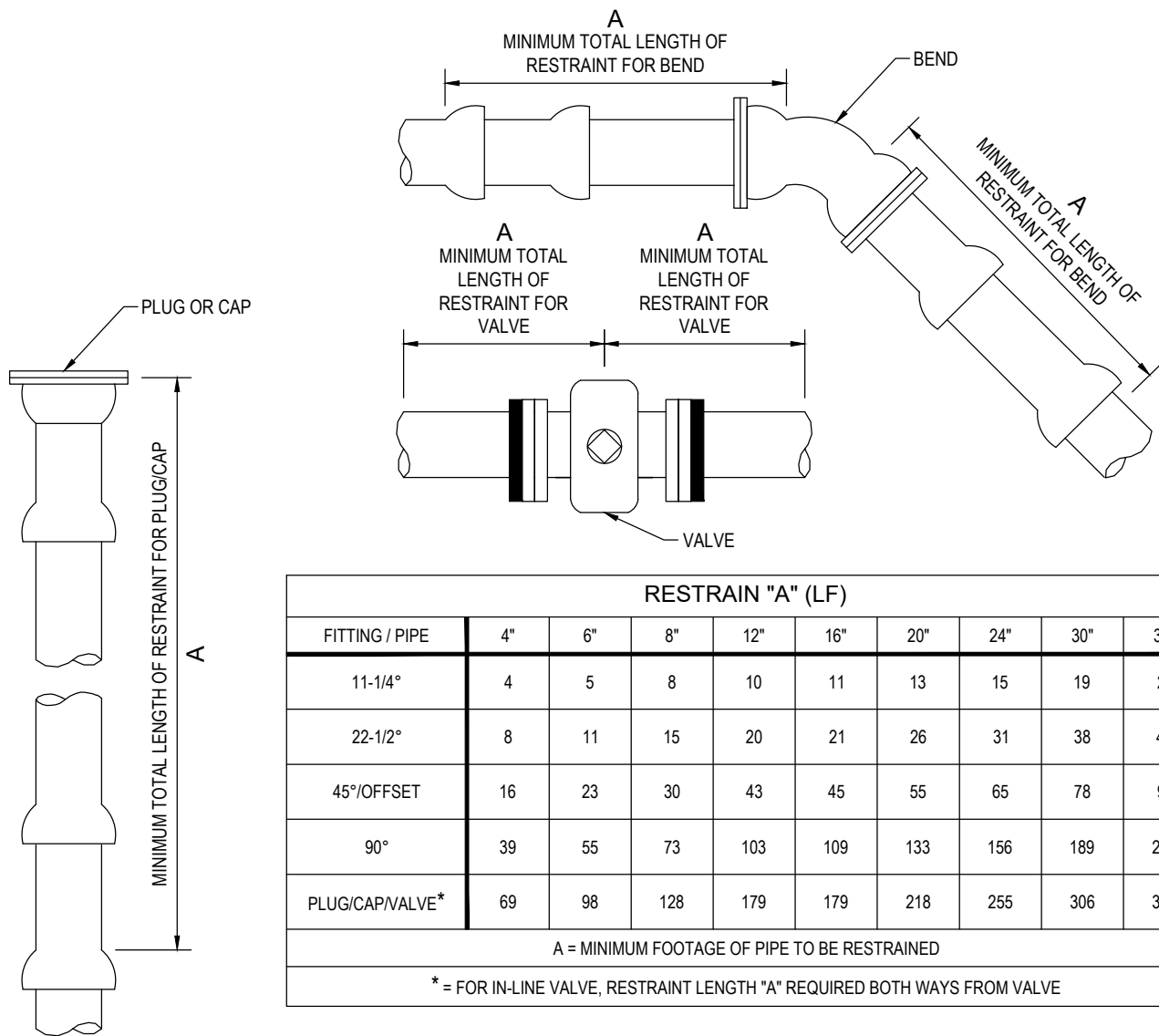

| RESTRAIN "A" (LF) | | | | | | | | | |
|---|----|----|-----|-----|-----|-----|-----|-----|-----|
| FITTING / PIPE | 4" | 6" | 8" | 12" | 16" | 20" | 24" | 30" | 36" |
| 11-1/4° | 4 | 5 | 8 | 10 | 11 | 13 | 15 | 19 | 21 |
| 22-1/2° | 8 | 11 | 15 | 20 | 21 | 26 | 31 | 38 | 44 |
| 45°/OFFSET | 16 | 23 | 30 | 43 | 45 | 55 | 65 | 78 | 91 |
| 90° | 39 | 55 | 73 | 103 | 109 | 133 | 156 | 189 | 220 |
| PLUG/CAP/VALVE* | 69 | 98 | 128 | 179 | 179 | 218 | 255 | 306 | 356 |
| A = MINIMUM FOOTAGE OF PIPE TO BE RESTRAINED | | | | | | | | | |
| * = FOR IN-LINE VALVE, RESTRAINT LENGTH "A" REQUIRED BOTH WAYS FROM VALVE | | | | | | | | | |

NOTES:

1. THIS TABLE IS BASED ON:
 - a. MAXIMUM TEST PRESSURE OF 190 PSI
 - b. LAYING CONDITION TYPE 2 (SEE DETAILS 2.01 AND 2.02)
 - c. POOR SOIL CONDITIONS
 - d. USING D.I.P.
 - e. 3 FEET OF COVER FOR 12" AND SMALLER MAINS; 4 FEET OF COVER FOR 16" AND LARGER MAINS
 - f. HORIZONTAL BENDS ONLY - ENGINEER TO SUBMIT CALCULATIONS FOR VERTICAL RESTRAINTS
2. "RESTRAINED" PIPE SHALL BE MANUFACTURED RESTRAINED JOINT PIPE, PUSH-ON JOINT PIPE RESTRAINED W/GASKET-TYPE "GRIPPER RESTRAINTS", OR MECHANICAL JOINT PIPE RESTRAINED BY MEGALUG (OR APPROVED EQUIVALENT).
3. ANY ADDITIONAL FITTINGS WITHIN THE RESTRAINED SECTION SHALL BE RESTRAINED ACCORDINGLY.

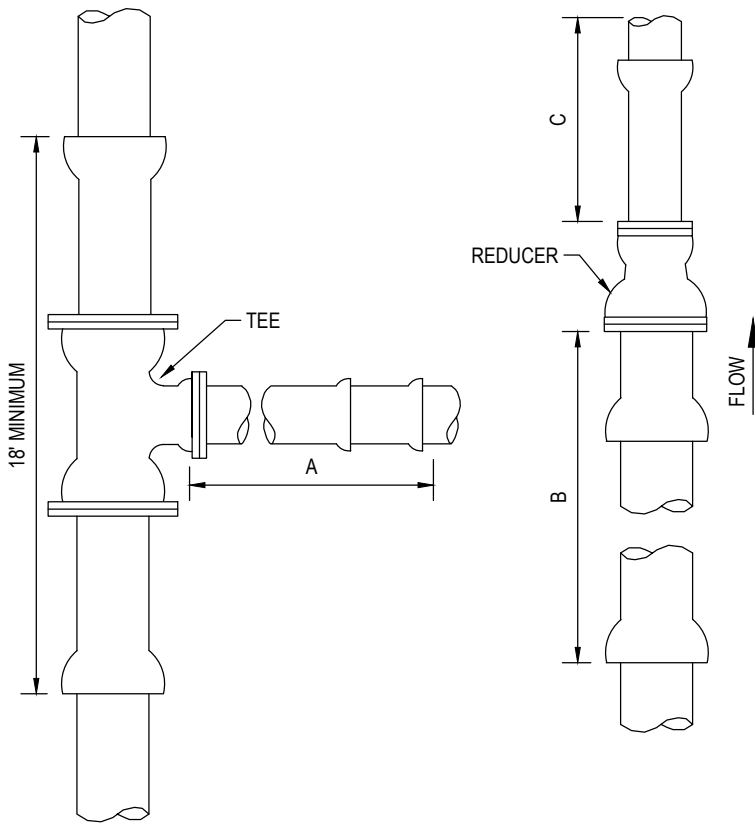

| FITTING SIZE | RESTRAIN (LF) | | UNRESTRAINED STRAIGHT RUN (LF) |
|--------------|---------------|-------------|--------------------------------|
| | TEE "A" | REDUCER "B" | REDUCER "C" |
| 4x4 | 31 | * | * |
| 6x4 | 14 | 50 | 74 |
| 6x6 | 60 | * | * |
| 8x4 | A.T. | 91 | 178 |
| 8x6 | 48 | 54 | 70 |
| 8x8 | 90 | * | * |
| 12x4 | A.T. | 155 | 455 |
| 12x6 | 24 | 130 | 260 |
| 12x8 | 71 | 95 | 144 |
| 12x12 | 143 | * | * |
| 16x6 | A.T. | 151 | 401 |
| 16x8 | 34 | 130 | 265 |
| 16x12 | 96 | 76 | 103 |
| 16x16 | 148 | * | * |
| 20x6 | A.T. | 195 | 659 |
| 20x8 | 18 | 180 | 461 |
| 20x12 | 85 | 136 | 233 |
| 20x16 | 139 | 76 | 96 |
| 20x20 | 186 | * | * |
| 24x6 | A.T. | 236 | 971 |
| 24x8 | A.T. | 224 | 700 |
| 24x12 | 74 | 188 | 391 |
| 24x16 | 130 | 139 | 215 |
| 24x20 | 180 | 76 | 93 |
| 24x24 | 224 | * | * |
| 30x6 | A.T. | 293 | 1534 |
| 30x8 | A.T. | 283 | 1130 |
| 30x12 | 56 | 255 | 678 |
| 30x16 | 118 | 216 | 426 |
| 30x20 | 169 | 168 | 260 |
| 30x24 | 215 | 108 | 138 |
| 30x30 | 275 | * | * |
| 36x6 | A.T. | 345 | 2230 |
| 36x8 | A.T. | 336 | 1660 |
| 36x12 | 38 | 314 | 1030 |
| 36x16 | 104 | 283 | 689 |
| 36x20 | 159 | 244 | 466 |
| 36x24 | 206 | 195 | 306 |
| 36x30 | 269 | 108 | 133 |
| 36x36 | 326 | * | * |

A.T. = RESTRAINT REQUIRED AT TEE ONLY. * = NOT APPLICABLE

NOTES:

1. THIS TABLE IS BASED ON:
 - a. MAXIMUM TEST PRESSURE OF 190 PSI
 - b. LAYING CONDITION TYPE 2 (SEE DETAILS 2.01 AND 2.02)
 - c. POOR SOIL CONDITIONS
 - d. USING D.I.P.
 - e. 3 FEET OF COVER FOR 12" AND SMALLER MAINS; 4 FEET OF COVER FOR 16" AND LARGER MAINS
 - f. HORIZONTAL BENDS ONLY - ENGINEER TO SUBMIT CALCULATIONS FOR VERTICAL RESTRAINTS
2. RESTRAINT FOR REDUCERS: IF "C" STRAIGHT RUN OF PIPE DOWNSTREAM OF REDUCER NOT AVAILABLE, THE RESTRAIN "B" UPSTREAM OF REDUCER.
3. "RESTRAINED" PIPE SHALL BE MANUFACTURED RESTRAINED JOINT PIPE, PUSH-ON JOINT PIPE RESTRAINED W/GASKET-TYPE "GRIPPER RESTRAINTS", OR MECHANICAL JOINT PIPE RESTRAINED BY MEGALUG (OR APPROVED EQUIVALENT).
4. ANY ADDITIONAL FITTINGS WITHIN THE RESTRAINED SECTION SHALL BE RESTRAINED ACCORDINGLY.



LAST REVISION

MAY 2021

**RESTRAINED JOINT STANDARD
FOR TEES AND REDUCERS**

2.12A

PLAN VIEW

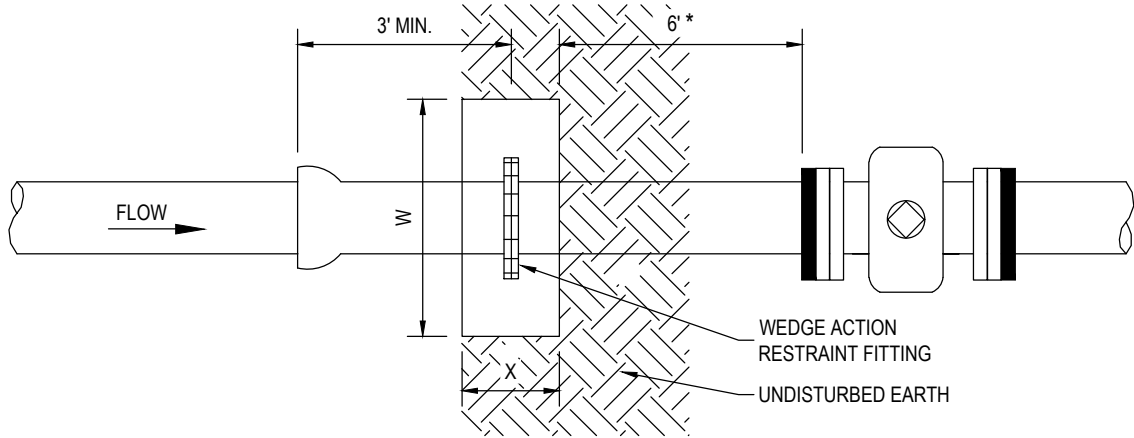

PROFILE

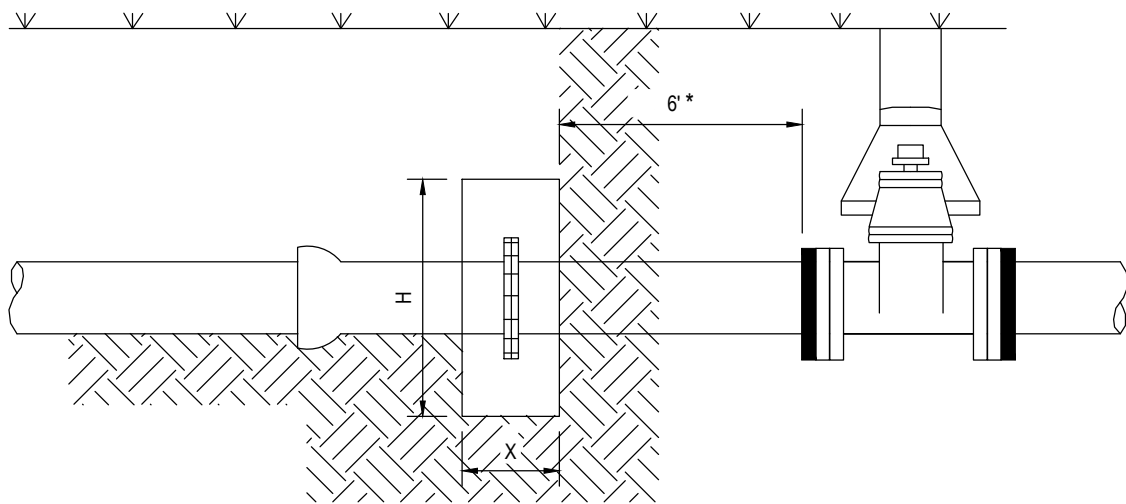

| SIZE (D) | 4" | 6" | 8" | 12" | 16" | 20" | 24" |
|----------------------------------|----------|----------|----------|----------|----------|----------|----------|
| THRUST (LBS.) | 3,439 | 7,104 | 12,223 | 26,002 | 45,180 | 69,624 | 99,330 |
| BEARING AREA (FT. ²) | 2.58 | 5.33 | 9.17 | 19.50 | 33.89 | 52.22 | 74.50 |
| CONCRETE (YDS. ³) | 0.15 | 0.31 | 0.71 | 1.51 | 3.29 | 5.07 | 7.23 |
| H (FT.) | 1.6 | 2.4 | 3.1 | 4.5 | 6.0 | 7.4 | 8.8 |
| W (FT.) | 1.6 | 2.4 | 3.1 | 4.5 | 6.0 | 7.4 | 8.8 |
| X (FT.) | 1.5 MIN. | 1.5 MIN. | 2.0 MIN. | 2.0 MIN. | 2.5 MIN. | 2.5 MIN. | 2.5 MIN. |

NOTES:

1. CONCRETE SHALL BE KEPT AT SUFFICIENT DISTANCE FROM JOINT FOR REMOVAL OF ALL JOINT ACCESSORIES INCLUDING BOLTS.
2. ALL BEARING SURFACES TO BE CARRIED TO UNDISTURBED SOIL.
3. THIS TABLE SHOWS THE MINIMUM SIZE THRUST BLOCKS FOR SOIL BEARING PRESSURE OF 2000 PSF AND AN INTERNAL PRESSURE OF 190 PSI. COVER TO T.O.P. IS 3 FEET FOR 12" AND SMALLER MAINS; 4 FEET FOR 16" AND LARGER MAINS.
4. POOR AND WET SOIL (SILTY SOILS, CLAY, MUCK AND PEAT) WILL REQUIRE LARGER THRUST BLOCKS, AS DIRECTED BY CITY ENGINEER.
5. FITTINGS SHALL BE COMPLETELY POLYWRAPPED PRIOR TO POURING THRUST BLOCKS.

* CLOSEST DISTANCE TO VALVE FOR DEADMAN TO REMAIN EFFECTIVE.

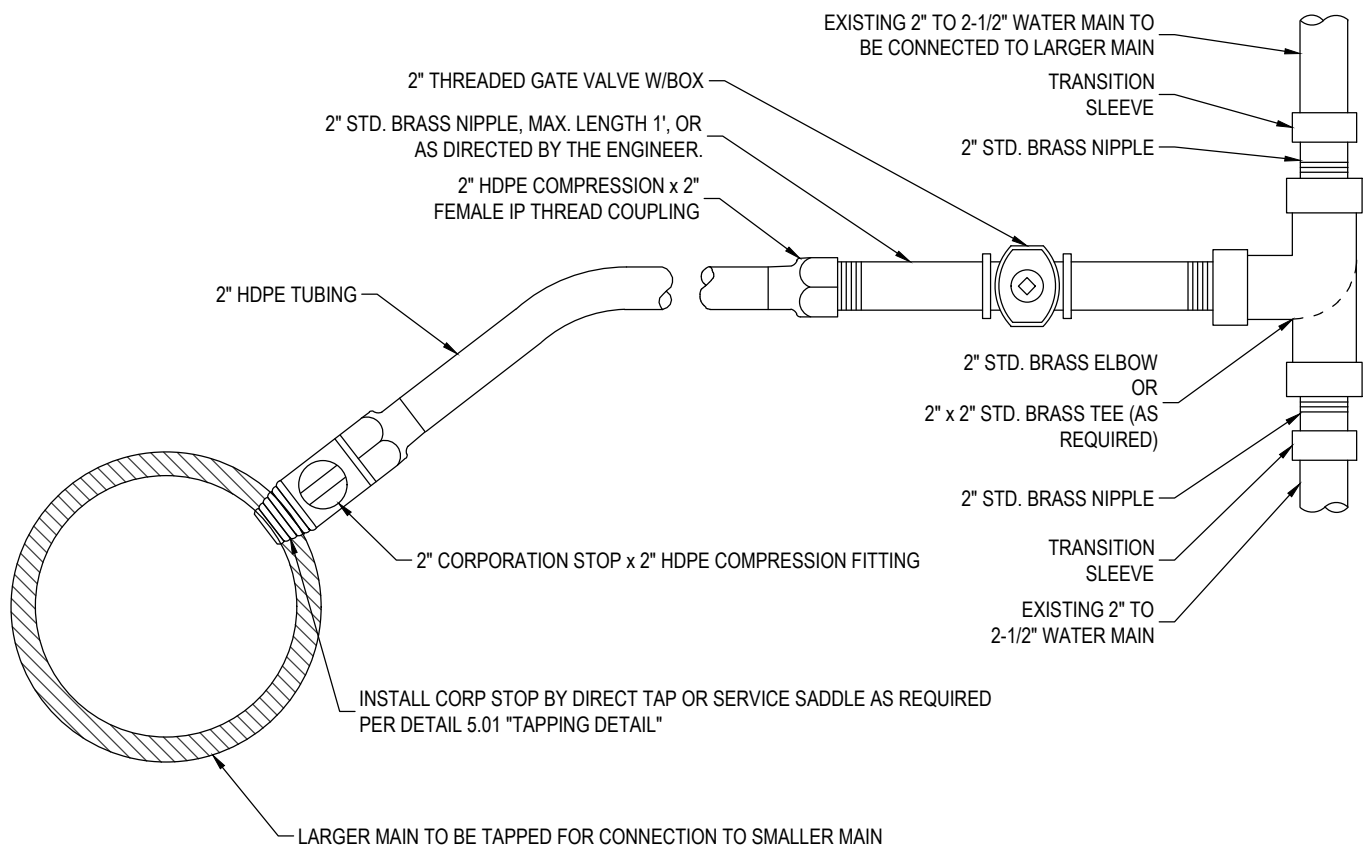

NOTE:
SEE DETAIL 5.01 TO DETERMINE WHEN SADDLES ARE REQUIRED FOR CORP INSTALLATION. VALVE SHALL BE SET IN ACCORDANCE WITH DETAIL 3.01.

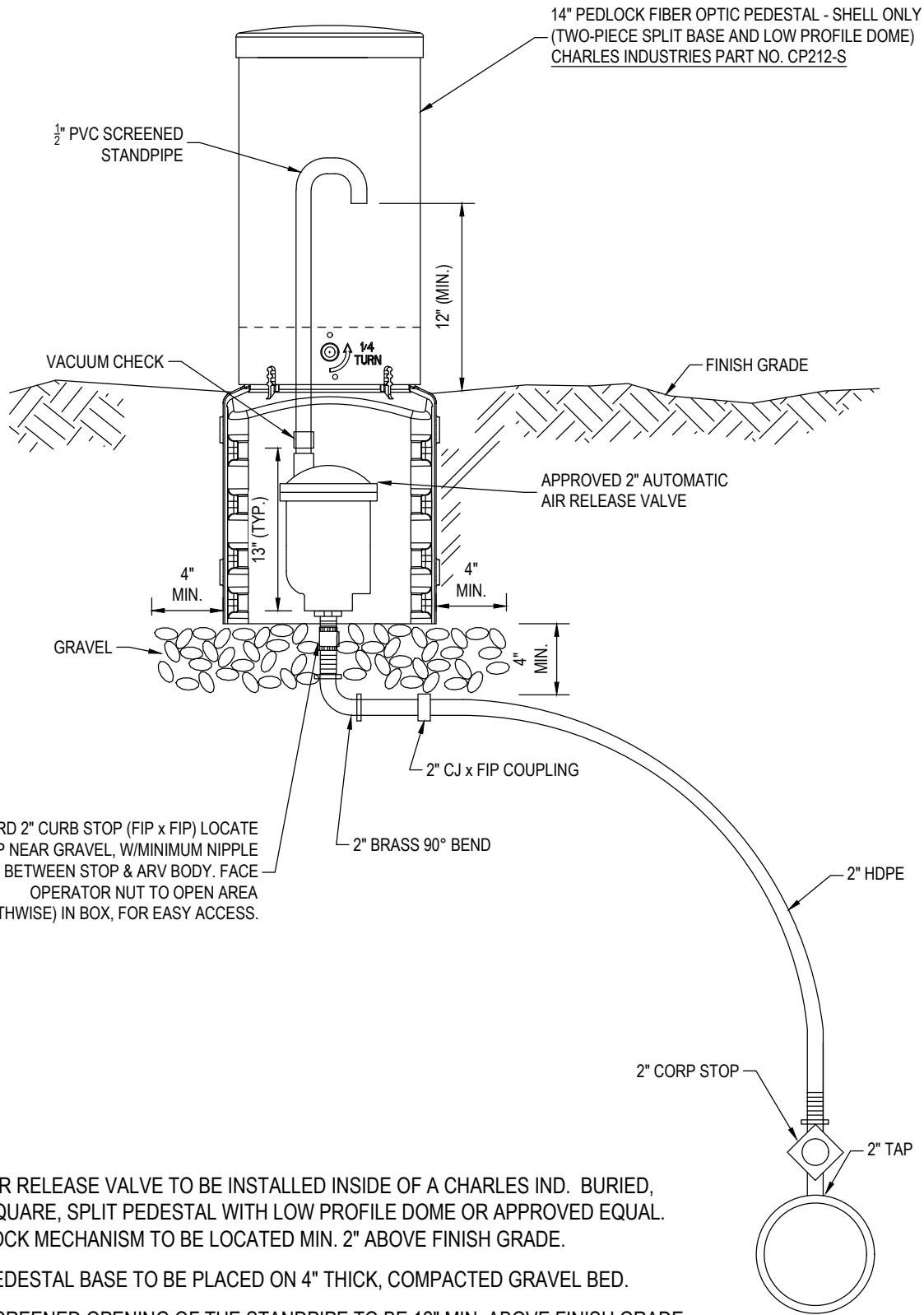

NOTES:

1. AIR RELEASE VALVE TO BE INSTALLED INSIDE OF A CHARLES IND. BURIED, SQUARE, SPLIT PEDESTAL WITH LOW PROFILE DOME OR APPROVED EQUAL. LOCK MECHANISM TO BE LOCATED MIN. 2" ABOVE FINISH GRADE.
2. PEDESTAL BASE TO BE PLACED ON 4" THICK, COMPACTED GRAVEL BED.
3. SCREENED OPENING OF THE STANDPIPE TO BE 12" MIN. ABOVE FINISH GRADE.

CHARLES INDUSTRIES LLPH MODEL 111
 (TWO-PIECE, SPLIT BASE AND LOW PROFILE DOME)
 CHARLES INDUSTRIES PART NO. 111 SS07-10002 BK

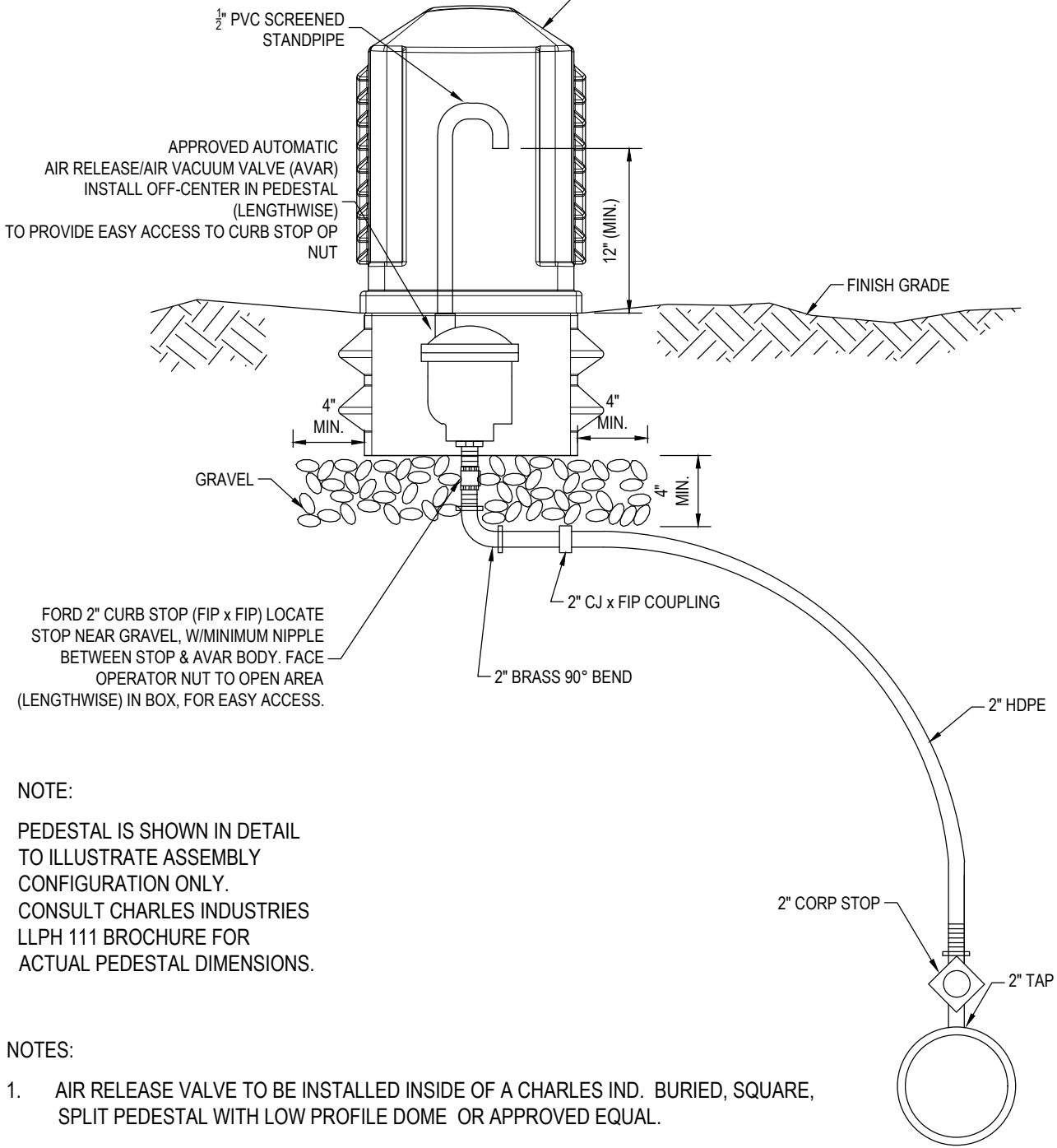

NOTE:

PEDESTAL IS SHOWN IN DETAIL TO ILLUSTRATE ASSEMBLY CONFIGURATION ONLY. CONSULT CHARLES INDUSTRIES LLPH 111 BROCHURE FOR ACTUAL PEDESTAL DIMENSIONS.

NOTES:

1. AIR RELEASE VALVE TO BE INSTALLED INSIDE OF A CHARLES IND. BURIED, SQUARE, SPLIT PEDESTAL WITH LOW PROFILE DOME OR APPROVED EQUAL.
2. LOCK MECHANISM TO BE LOCATED MIN. 2" ABOVE FINISH GRADE.
3. PEDESTAL BASE TO BE PLACED ON 4" THICK, COMPACTED GRAVEL BED, ON TOP OF 6" THICK 2'X2' CONCRETE PAD.
4. OBTAIN (2) REFLECTIVE WATER STICKERS FROM CITY AND AFFIX TO PEDESTAL.



LAST REVISION
 MAY 2021

AUTOMATIC AIR RELEASE/AIR VACUUM VALVE

2.14B

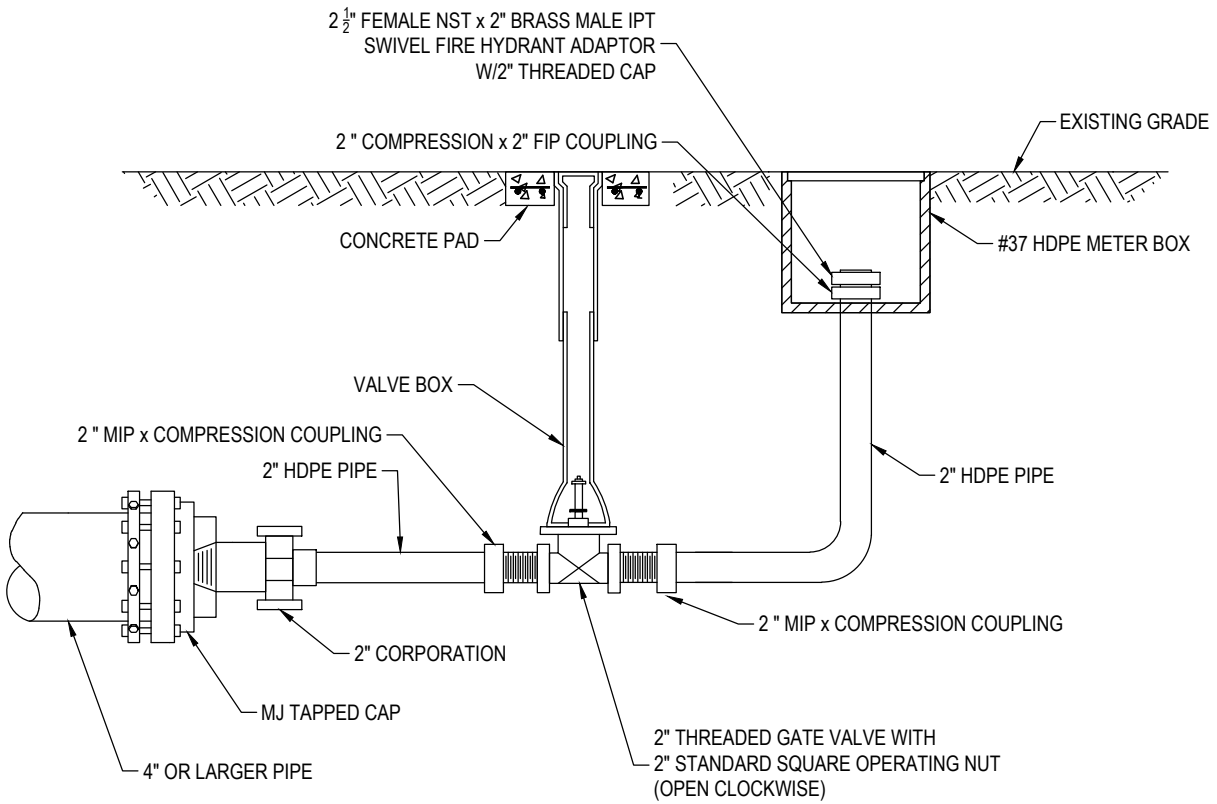

BLOW-OFF FOR \geq 4" MAINS

NO GALVANIZED PIPES OR FITTINGS ALLOWED.
SCHEDULE 80 PVC ALLOWED.

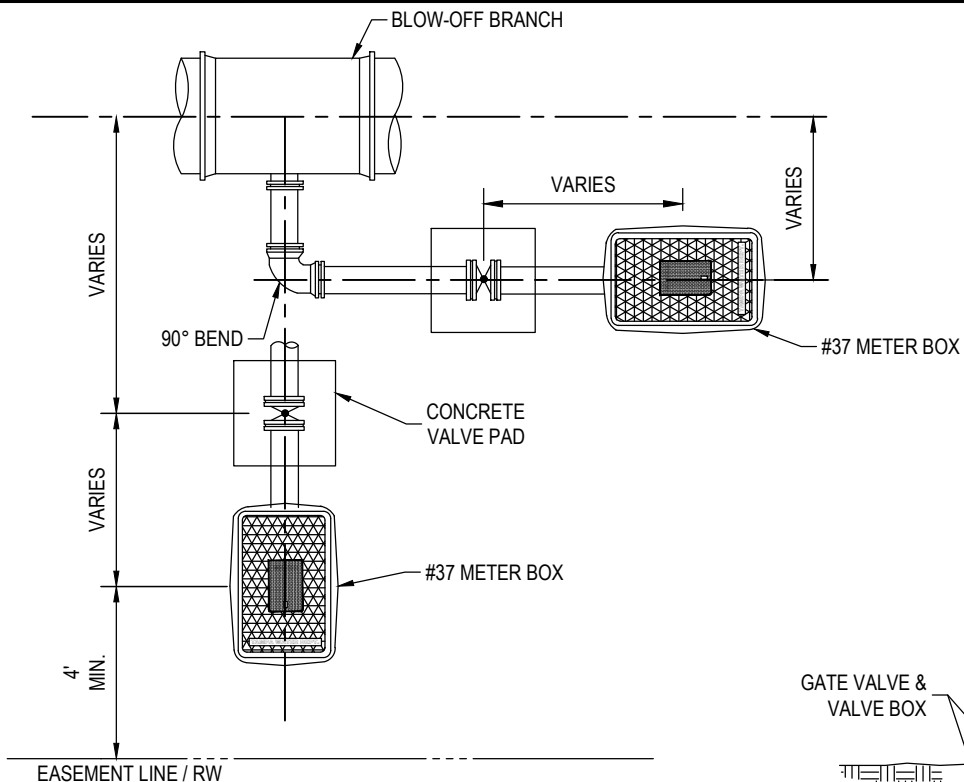

PLAN

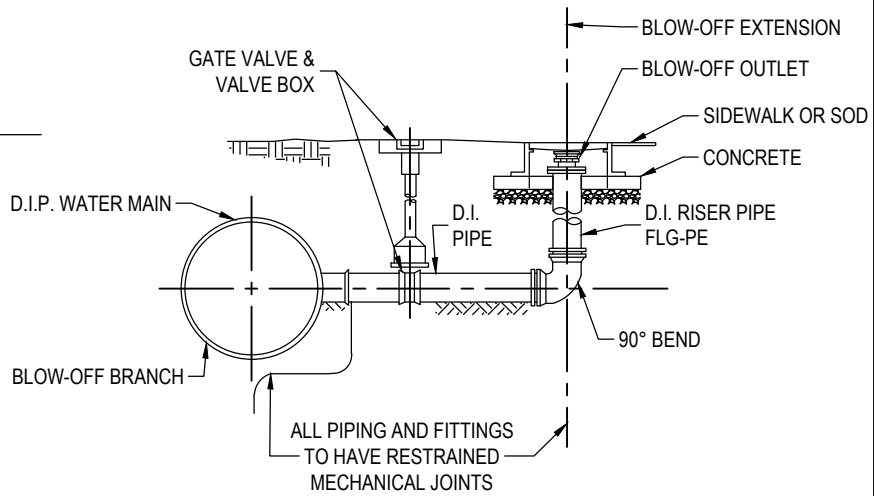

PROFILE

NOTES:

1. ASSEMBLY VARIES WITH SITE CONDITIONS
2. ENCASE ALL DUCTILE IRON PIPE AND FITTINGS. IN POLYETHYLENE ENCASEMENT IN ACCORDANCE WITH AWWA-C 105.
3. METER BOX PER STANDARD DETAIL 5.11 OR 5.11A.
4. INSTALL BENDS AS NEED TO CROSS EXISTING UTILITIES.
5. RESTRAIN ALL JOINTS.

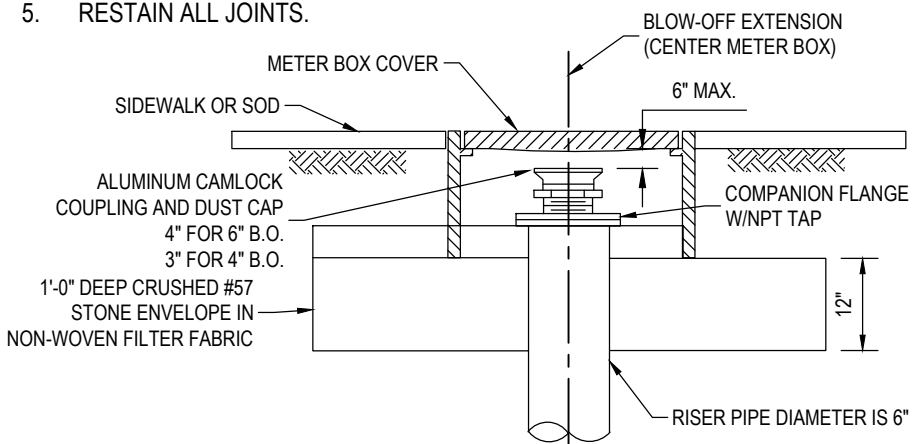

BLOW-OFF OUTLET DETAIL

NOT TO SCALE

NOTE:
CONTRACTOR SHALL DRILL 1/4" HOLE IN CENTER OF CAMLOCK DUST CAP.



LAST REVISION
MAY 2021

BLOW-OFF VALVE ASSEMBLY
FOR 4" & 6" MAINS W/DI, CI OR PVC PIPE -
LATERAL CONNECTION

2.17C

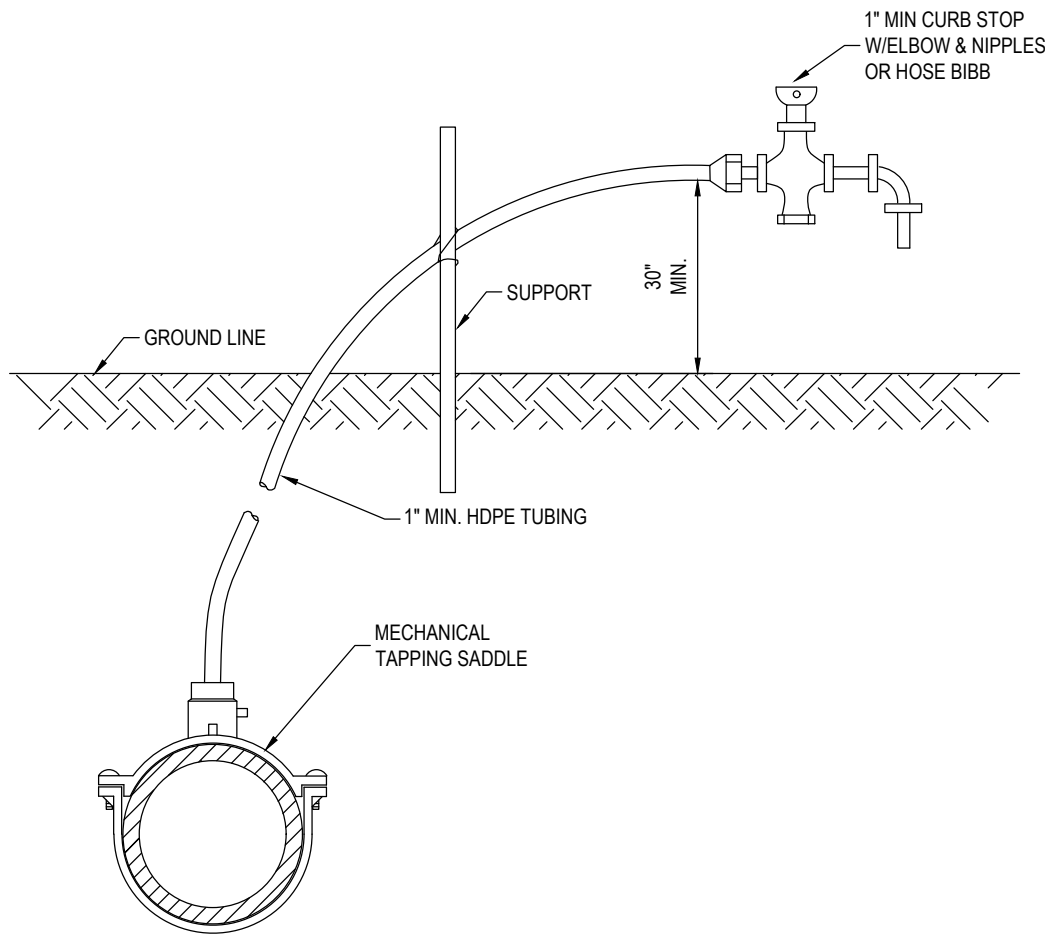

NOTES:

1. WATER OUTLET SHALL BE HELD UP OFF THE GROUND SO AS NOT TO INTERFERE WITH THE SAMPLING PROCESS.
2. CORPORATION STOP TO BE REMOVED AND BRASS PLUG INSTALLED IN TAPPED MAIN AFTER OPERATION.

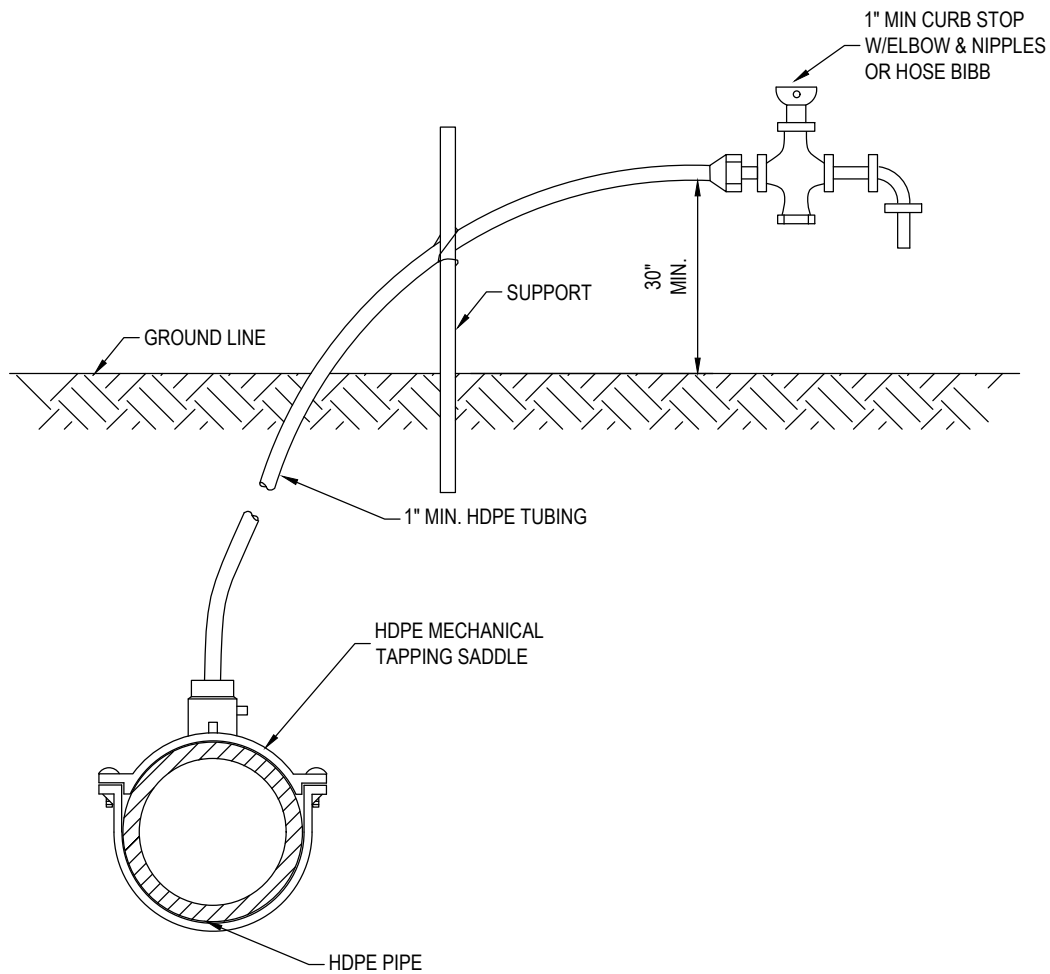

NOTES:

1. WATER OUTLET SHALL BE HELD UP OFF THE GROUND SO AS NOT TO INTERFERE WITH THE SAMPLING PROCESS.
2. CORPORATION STOP TO BE REMOVED AND PLUGGED AFTER OPERATION.

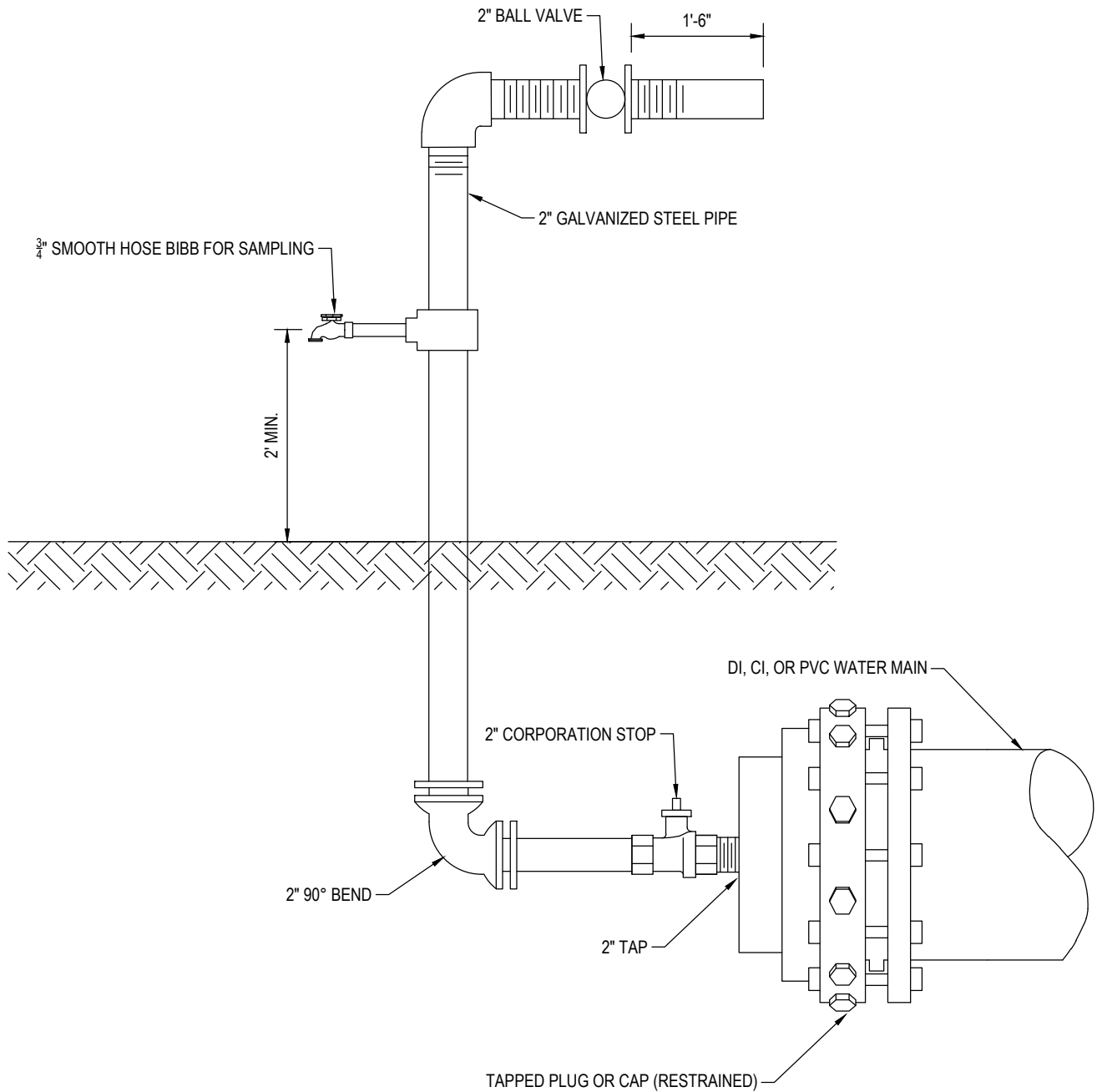

NOTES:

1. FOR DEAD-END MAINS, SAMPLE TAP TO BE INSTALLED ON A 2" TAPPED CAP/PLUG.
2. FLUSHING/SAMPLING ARRANGEMENT TO BE REMOVED AFTER DISINFECTION OF MAIN LINE.
3. AFTER OPERATION COMPLETE, INSTALL BRASS PLUG AT CORPORATION STOP.

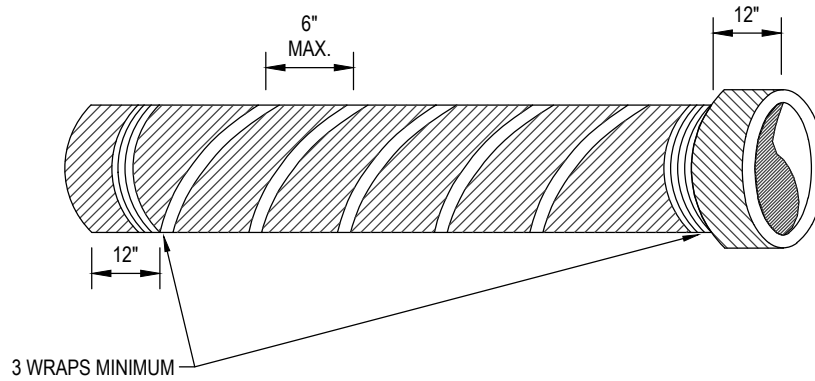

SPIRAL WRAP

NOTES:

1. TO ENSURE PROPER ADHESION, EACH PIPE RUN SHALL BE WRAPPED WITH A CONTINUOUS RUN OF TAPE.
2. ALL TAPE SHALL BE MIN. 2" BLUE VINYL TAPE FOR POTABLE WATER.

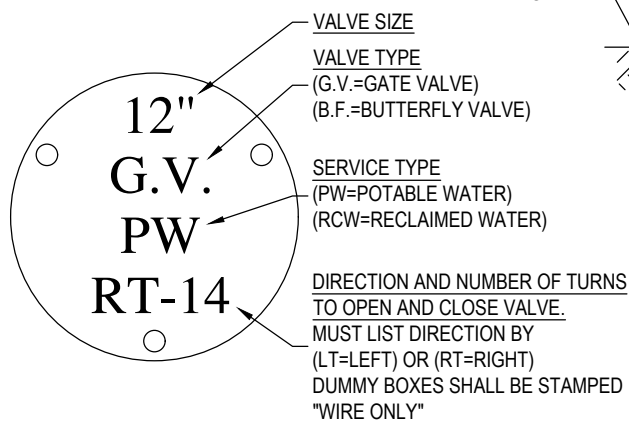
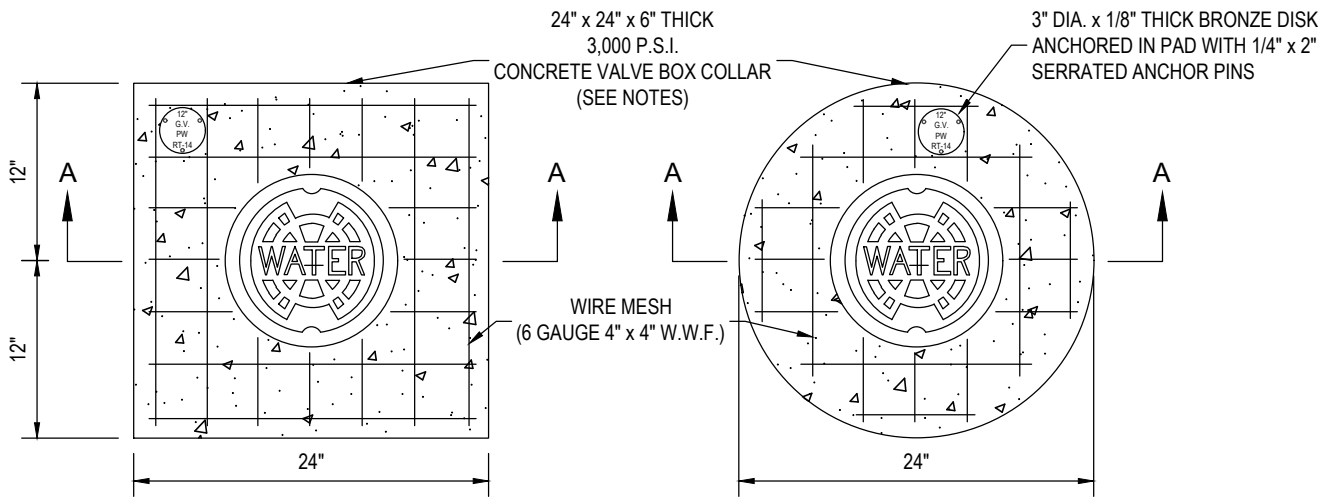

BRONZE DISK DETAIL

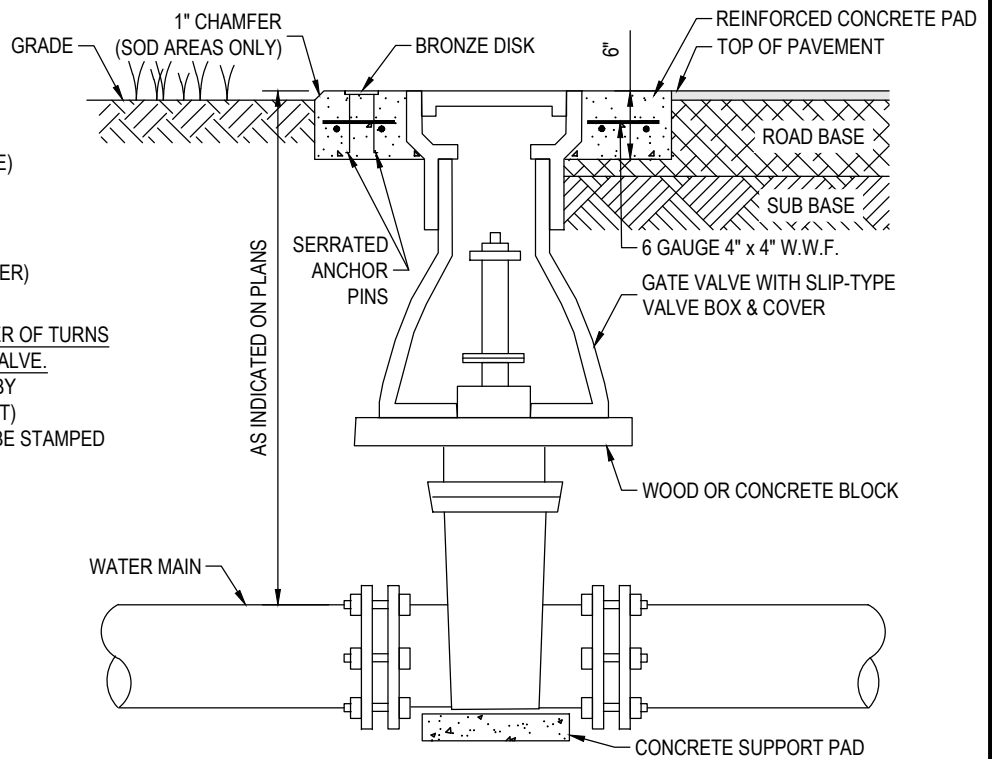

SECTION A-A

NOTES :

1. CIRCULAR OR SQUARE CONCRETE PAD REQUIRED FOR ALL VALVE BOX INSTALLATIONS IN PERVIOUS AREAS (I.E. OUTSIDE OF ROADWAY PAVEMENT, OUTSIDE OF CONCRETE/ASPHALT DRIVEWAYS, ETC.)
2. CAST IRON VALVE BOXES SHALL BE FIRMLY SUPPORTED AND CENTERED AND PLUMB OVER THE OPERATING NUT OF THE VALVE. VALVE BOX COVER SHALL BE FLUSH WITH THE SURFACE OF THE FINISHED PAVEMENT, OR GRADE OR AT SUCH OTHER LEVEL AS MAY BE DIRECTED BY THE DEPARTMENT.
3. "BLUE" WATER VALVE LOCATE MARKERS REQUIRED FOR ALL VALVE INSTALLATIONS.
4. EMBED BRONZE VALVE INFO DISK INTO CONCRETE VALVE BOX COLLAR.
5. ALL MATERIALS SHALL BE IN ACCORDANCE WITH THE LATEST T.W.D. APPROVED MATERIAL SPECIFICATIONS.
6. IF VALVE IS LOCATED WITHIN A SIDEWALK CONCRETE COLLAR MAY BE ELIMINATED AND DISK SET FLUSH DIRECTLY IN SIDEWALK.
7. BRONZE DISK REQUIRED FOR ALL VALVES AND DUMMY BOXES.



LAST REVISION
MAY 2021

VALVE INSTALLATION
W/VALVE BOX & PAD
FOR DI OR CI PIPE

3.01

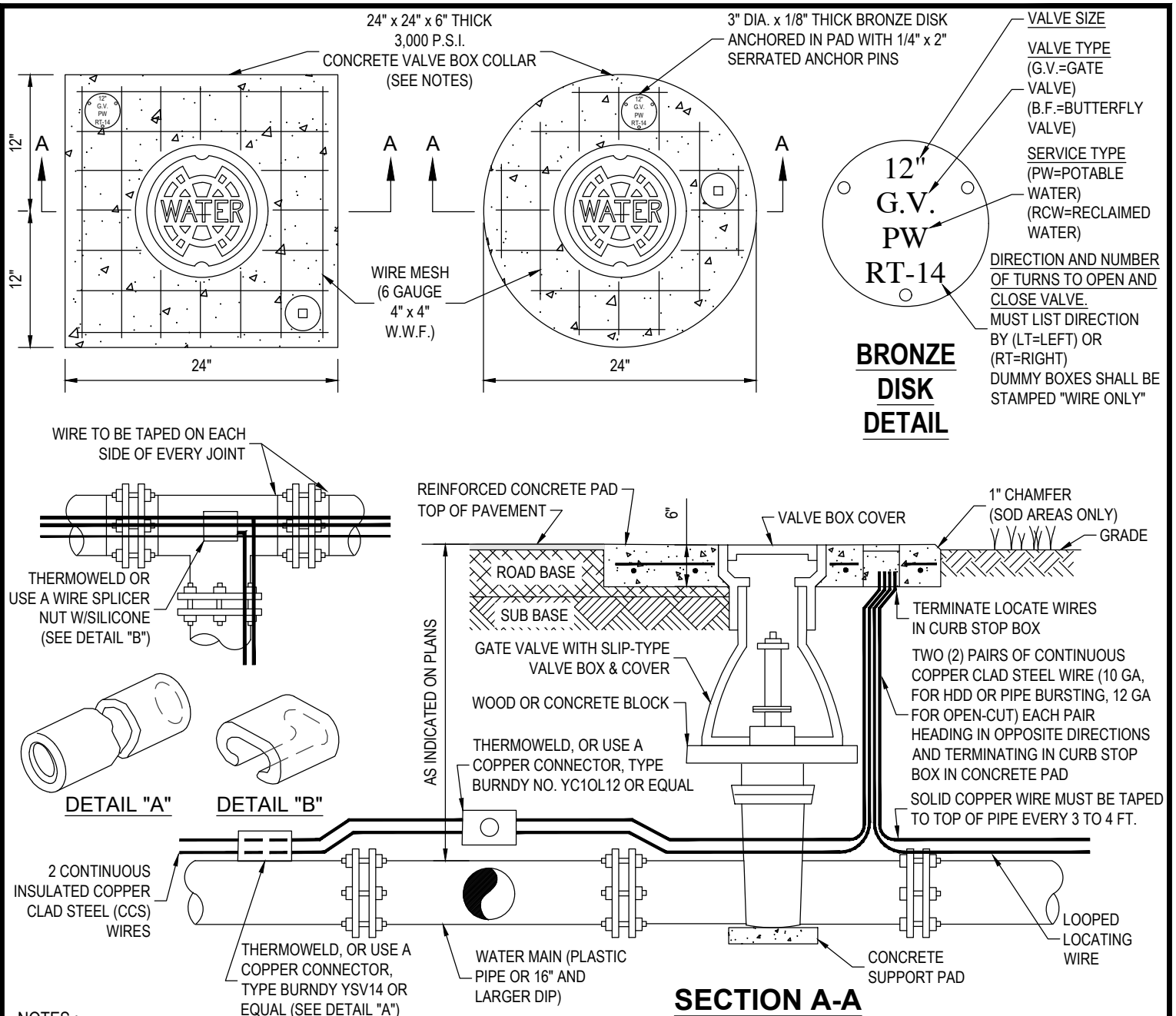

NOTES :

1. CIRCULAR OR SQUARE CONCRETE PAD REQUIRED FOR ALL VALVE BOX INSTALLATIONS IN PVIOUS AREAS (I.E. OUTSIDE OF ROADWAY PAVEMENT, OUTSIDE OF CONCRETE/ASPHALT DRIVEWAYS, ETC.)
2. CAST IRON VALVE BOXES SHALL BE FIRMLY SUPPORTED AND CENTERED AND PLUMB OVER THE OPERATING NUT OF THE VALVE. VALVE BOX COVER SHALL BE FLUSH WITH THE SURFACE OF THE FINISHED PAVEMENT, OR GRADE OR AT SUCH OTHER LEVEL AS MAY BE DIRECTED BY THE DEPARTMENT.
3. "BLUE" WATER VALVE LOCATE MARKERS REQUIRED FOR ALL VALVE INSTALLATIONS.
4. EMBED BRONZE VALVE INFO DISK INTO CONCRETE VALVE BOX COLLAR.
5. ALL MATERIALS SHALL BE IN ACCORDANCE WITH THE LATEST T.W.D. APPROVED MATERIAL SPECIFICATIONS.
6. IF VALVE IS LOCATED WITHIN A SIDEWALK CONCRETE COLLAR MAY BE ELIMINATED AND DISK SET FLUSH DIRECTLY IN SIDEWALK.
7. BRONZE DISK REQUIRED FOR ALL VALVES AND DUMMY BOXES.
8. ALL CONNECTIONS SHALL BE SEALED WITH A BITUMINOUS COATING FOR CORROSION PROTECTION.



LAST REVISION
MAY 2021

VALVE INSTALLATION W/VALVE BOX &
PAD FOR PLASTIC PIPE WITH DOUBLE
COPPER TRACER WIRE ON PIPE

3.02

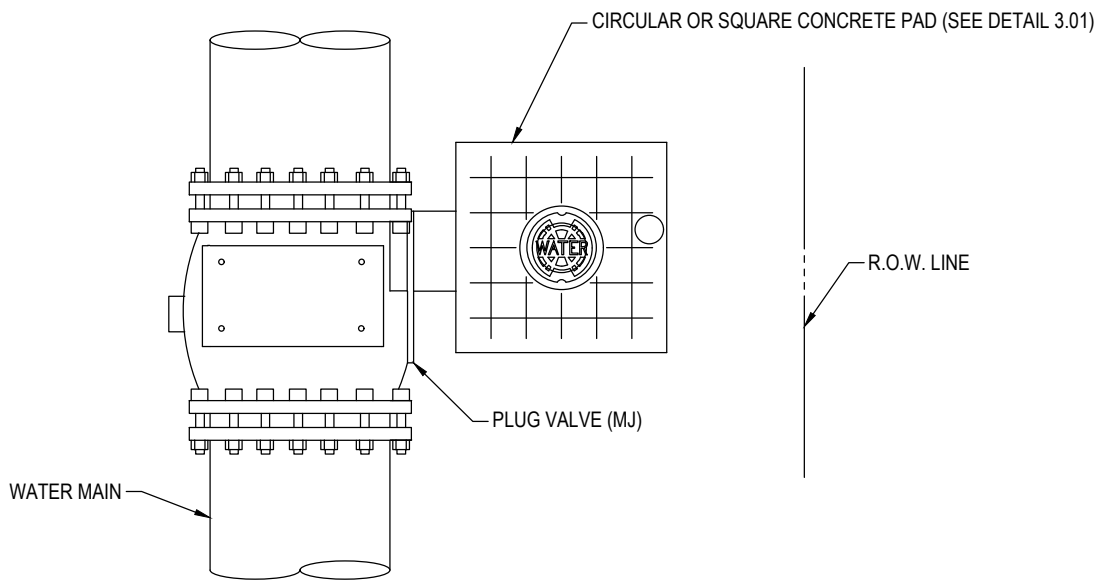

PLAN

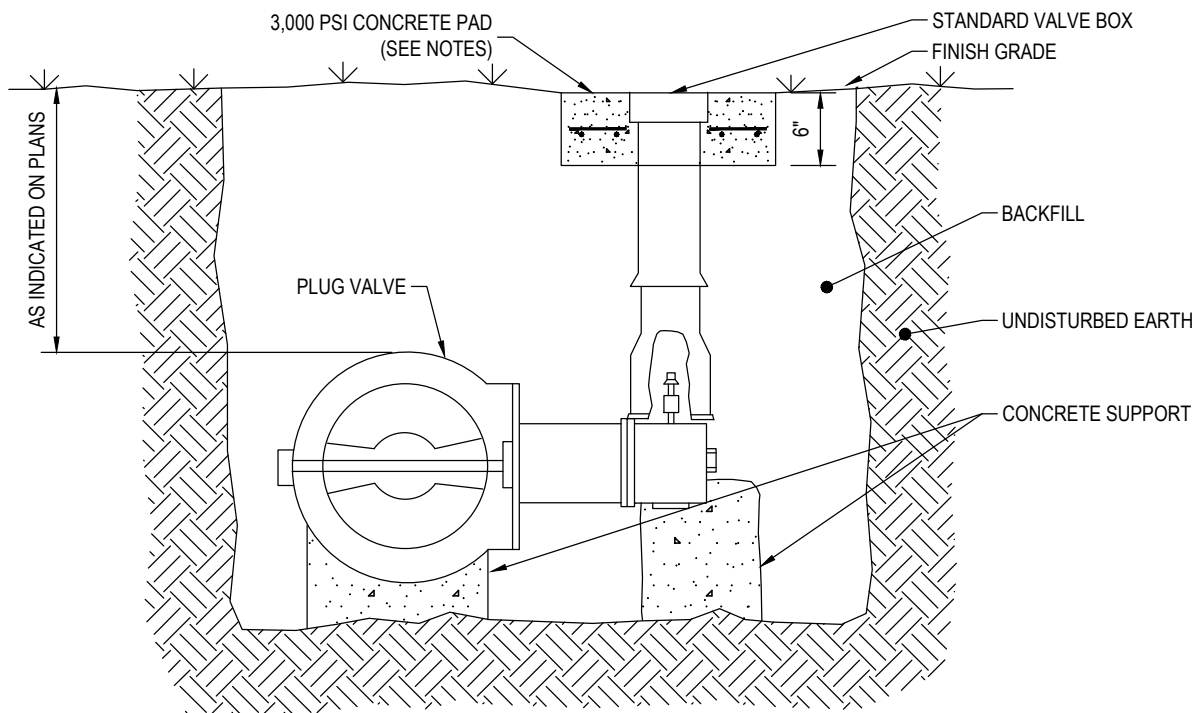

SECTION

NOTES:

1. CIRCULAR OR SQUARE CONCRETE PADS FOR VALVE BOX AND CONCRETE SUPPORTS AS SPECIFIED IN DETAIL ABOVE SHALL BE FURNISHED WITH ALL BUTTERFLY VALVE INSTALLATIONS.
2. ORIENT VALVE SO OPERATOR IS LOCATED ON THE SIDE OF THE PIPE NEAREST THE RIGHT-OF-WAY LINE.

VALVE BOX COVER

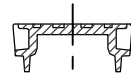

RISER

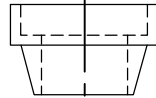

TOP SECTION

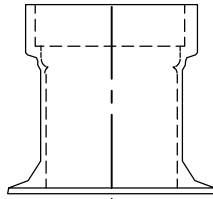

BOTTOM SECTION

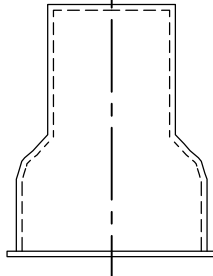

VALVE BOX ASSEMBLY

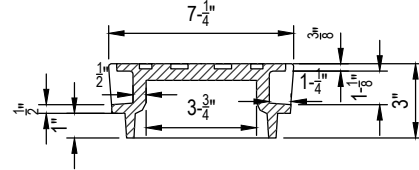
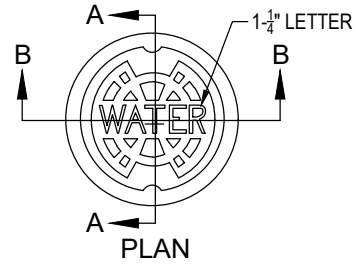

SECTION A-A

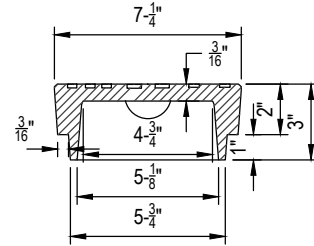

SECTION B-B

VALVE BOX COVER

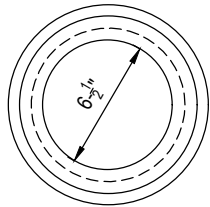

PLAN

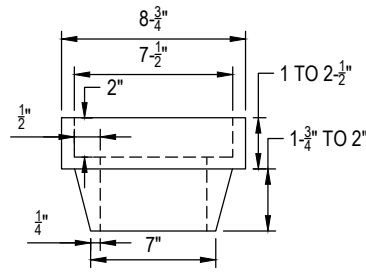

SIDE VIEW

RISER

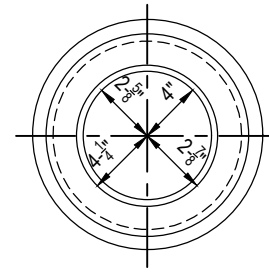

PLAN

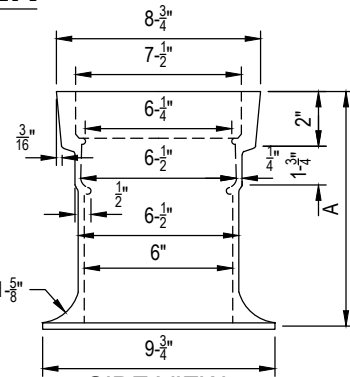

SIDE VIEW

TOP SECTION

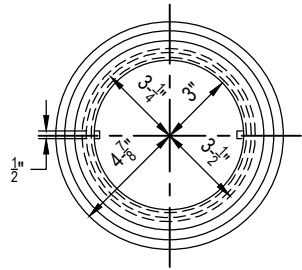

PLAN

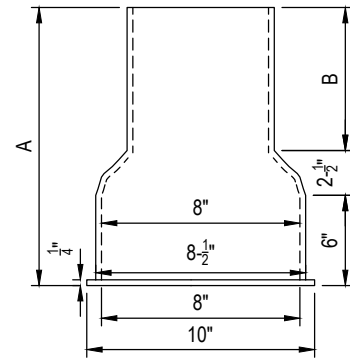

SIDE VIEW

BOTTOM SECTION

| | | |
|-------------|------|-----|
| TOP SECTION | SIZE | A |
| | 10" | 10" |
| | 16" | 16" |

| | | | |
|----------------|------|-----|---------|
| BOTTOM SECTION | SIZE | A | B |
| | 15" | 15" | 6-1/2" |
| | 24" | 24" | 15-1/2" |
| | 36" | 36" | 27-1/2" |



LAST REVISION
MAY 2021

VALVE BOX, SLIP TYPE

3.04

TO PROTECT VALVE BOX LOCATION DURING CLEARING & GRUBBING

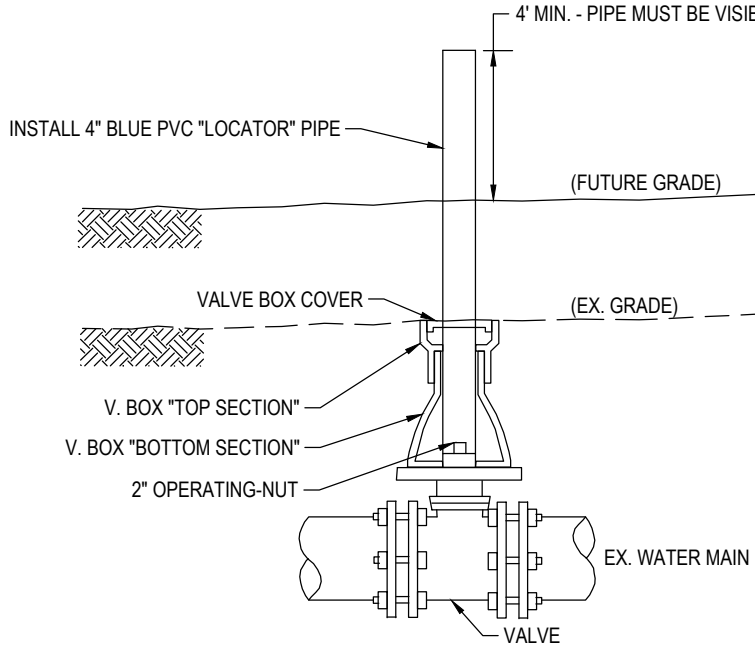

1. REMOVE (OR DO NOT INSTALL) V. BOX COVER & "TOP SECTION".
2. INSTALL 4" BLUE PVC PIPE INTO V. BOX "BOTTOM SECTION", OVER 2" OPERATING- NUT, & TO 4' MIN. ABOVE FUTURE GRADE.
3. PACK ANNULAR SPACE TO PREVENT BACKFILL SOILS ENTERING V. BOX "BOTTOM SECTION".

TO ADJUST HEIGHT OF VALVE BOX FOR CHANGED GRADE

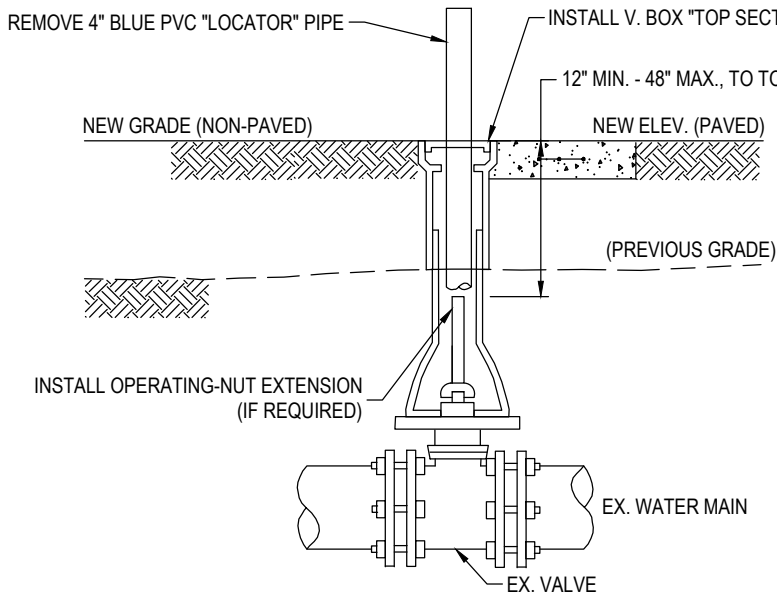

1. REMOVE PVC LOCATOR PIPE.
2. INSTALL APPROVED V. BOX "TOP SECTION" AND/OR RISER & COVER, SUCH THAT TOP OF COVER MATCHES NEW GRADE ELEVATION.
3. INSTALL STD CI OPERATING-NUT EXTENSION IF TOP OF OPERATING-NUT (T.O.N.) > 4' BELOW GRADE.
FINAL T.O.N. TO BE ≤ 4' DEEP.
4. IN NON-PAVED AREAS, CONSTRUCT 2'X2' (OR 2' DIA.) REINFORCED CONCRETE PAD, PER STD. DETAIL 3.01 (3000 P.S.I. CONCRETE, 6-GAUGE 4"X4" W.W.F.)

NOTES:

1. MATERIALS FOR & INSTALLATION OF VALVE BOXES & PADS SHALL CONFORM TO TAMPA WATER DEPT. SPECIFICATIONS & STD. CONSTRUCTION DETAILS (DETAILS 3.01 & 3.03)

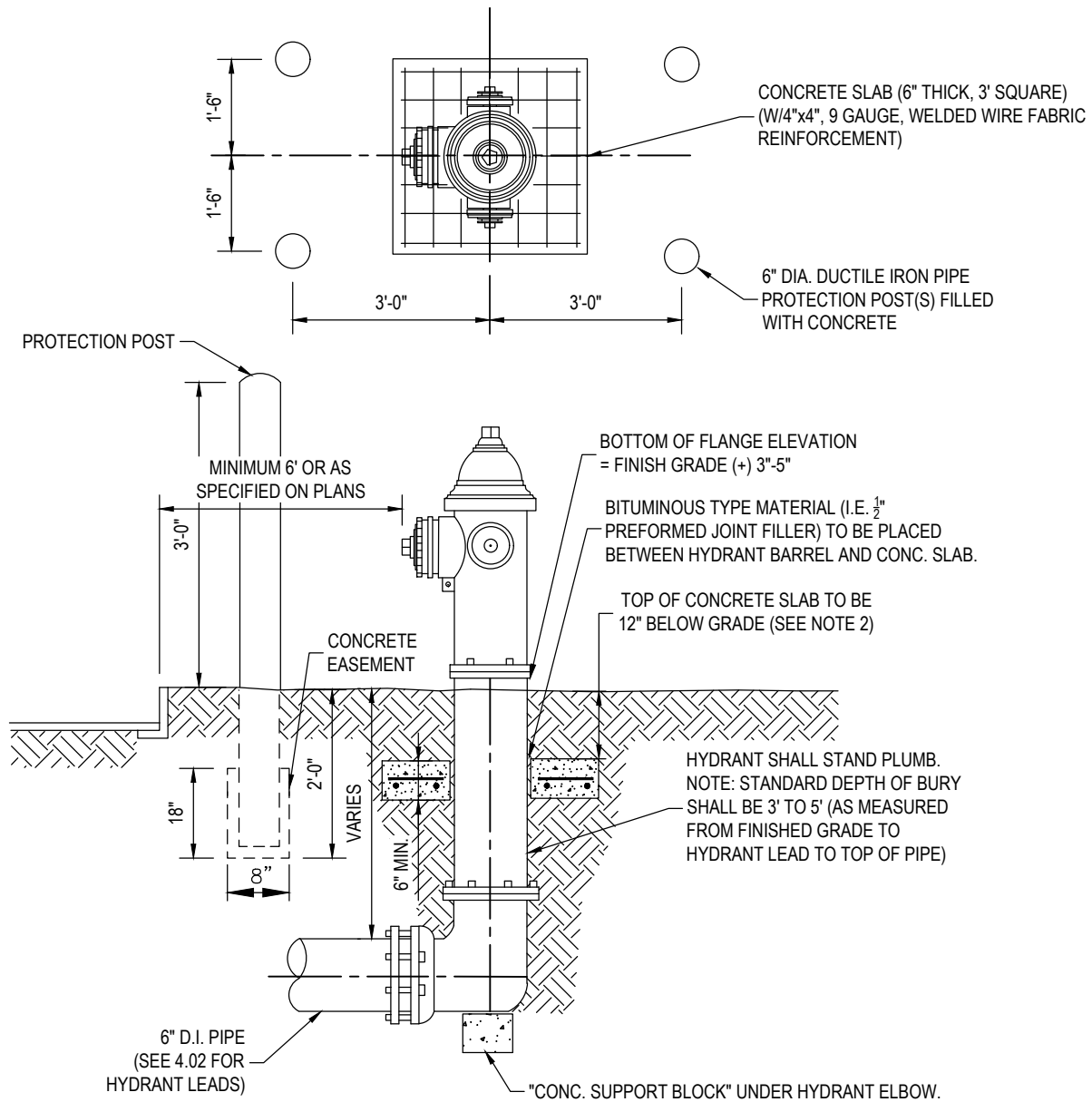

NOTES:

1. FIRE HYDRANT BARREL ABOVE THE GROUND LINE SHALL BE PAINTED WITH A HIGH-GRADE ENAMEL PAINT, FEDERAL SAFETY YELLOW (OSHA APPROVED), AND THE HYDRANT BONNET SHALL BE PAINTED OSHA GREEN.
2. CONCRETE SLAB MAY BE ELIMINATED IN AREAS WHERE HYDRANT IS SET IN SIDEWALK AND SIDEWALK HAS BEEN INSTALLED PRIOR TO FINAL ACCEPTANCE OF THE HYDRANT.
3. THRUST RESTRAINT FOR HYDRANT:
 - a) HYDRANT SHALL BE FIRMLY SUPPORTED UNDER ELBOW IN ALL METHODS BY SUPPORT BLOCK
 - b) ALL BACKFILL SHALL BE THOROUGHLY COMPACTED UNDER SUPPORT BLOCK AND UNDER THRUST COLLAR
 - c) ALL HYDRANT LEADS SHALL BE RESTRAINED BY MEGALUGS OR EQUIVALENT MECHANICAL RESTRAINTS
4. PROTECTION POSTS ARE REQUIRED WHEN HYDRANT IS LESS THAN 6 FEET FROM EDGE OF PAVEMENT, OR AS DIRECTED BY THE ENGINEER.
5. FOR PVC MAINS, INSTALL CONCRETE SUPPORT BLOCK UNDER ALL HYDRANT TEES.

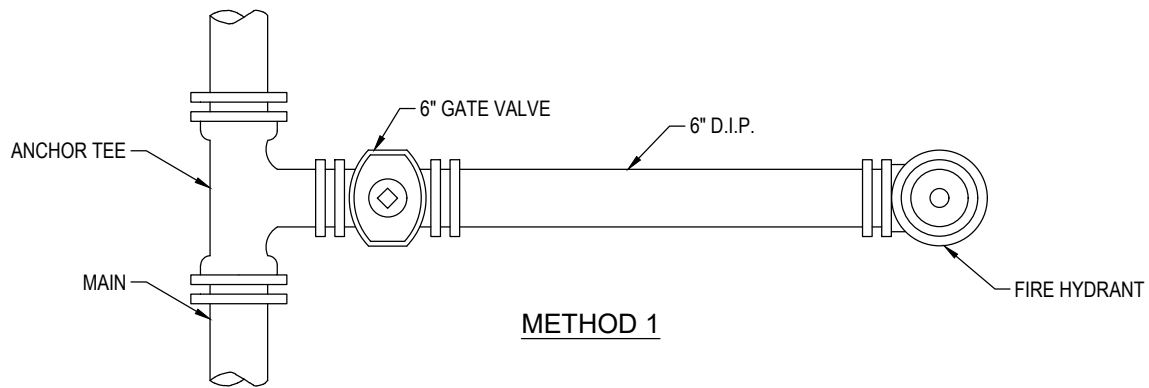

METHOD 1

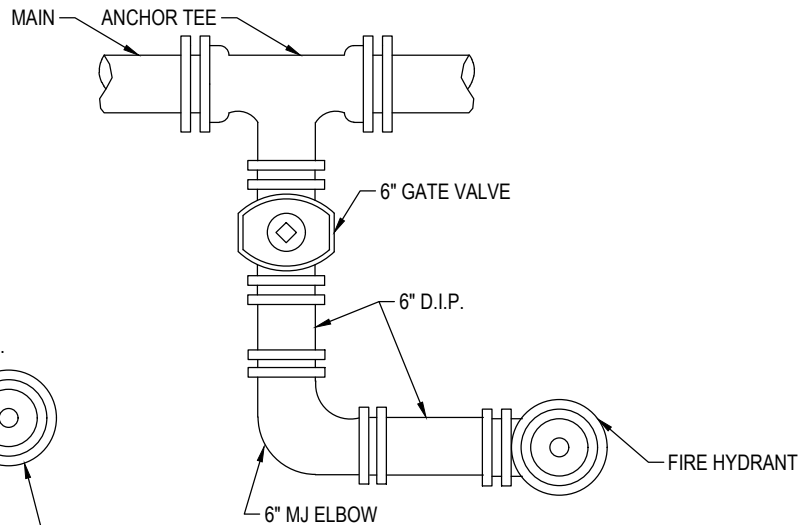

METHOD 3

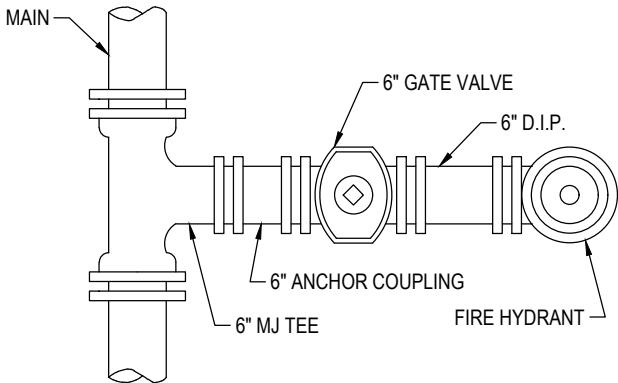

METHOD 2

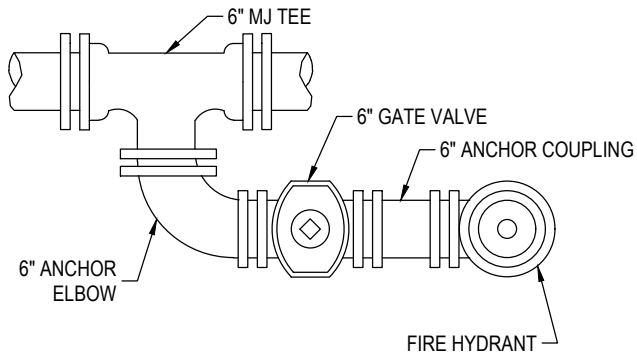

METHOD 4

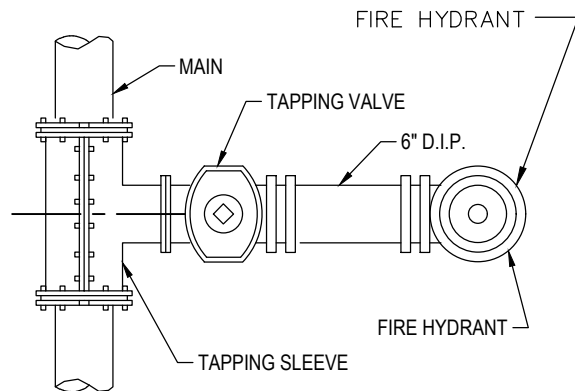

METHOD 5

NOTES:

1. VALVE SHALL BE SET IN ACCORDANCE WITH DETAIL 3.01. FOR HYDRANT SET, SEE DETAIL 4.01.
2. ALL VALVES SHALL BE ANCHORED TO BRANCH OF TEE ON ALL HYDRANT INSTALLATIONS.
3. ALL HYDRANT LEADS SHALL BE RESTRAINED BY MEGALUGS OR EQUIVALENT.
4. FOR PVC MAINS, INSTALL CONCRETE SUPPORT BLOCK UNDER HYDRANT TEES.

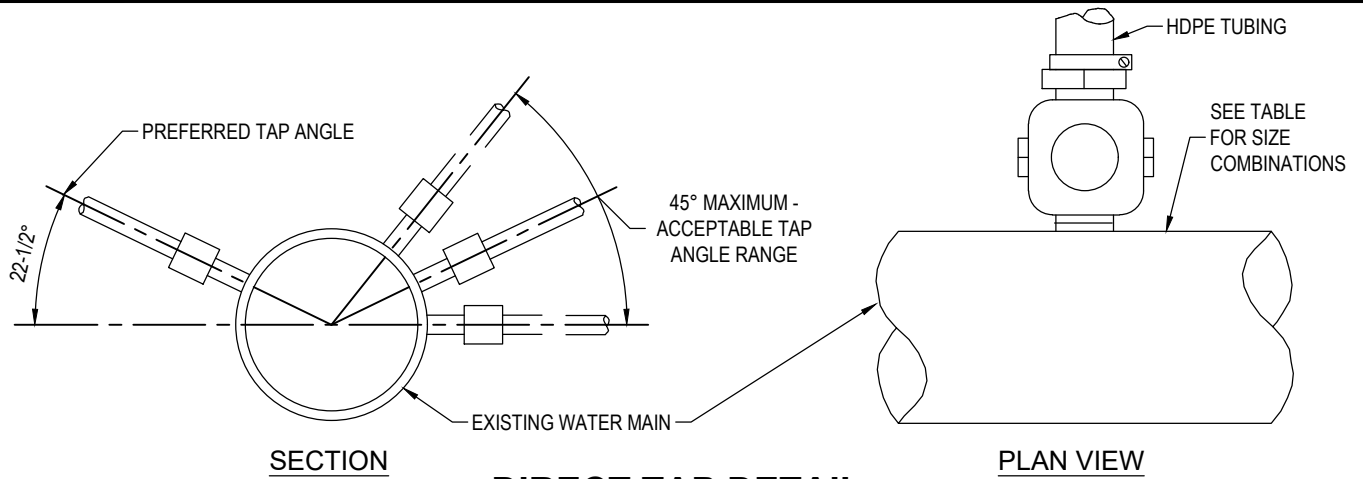

DIRECT TAP DETAIL

FOR APPROVED VARIANCES ONLY

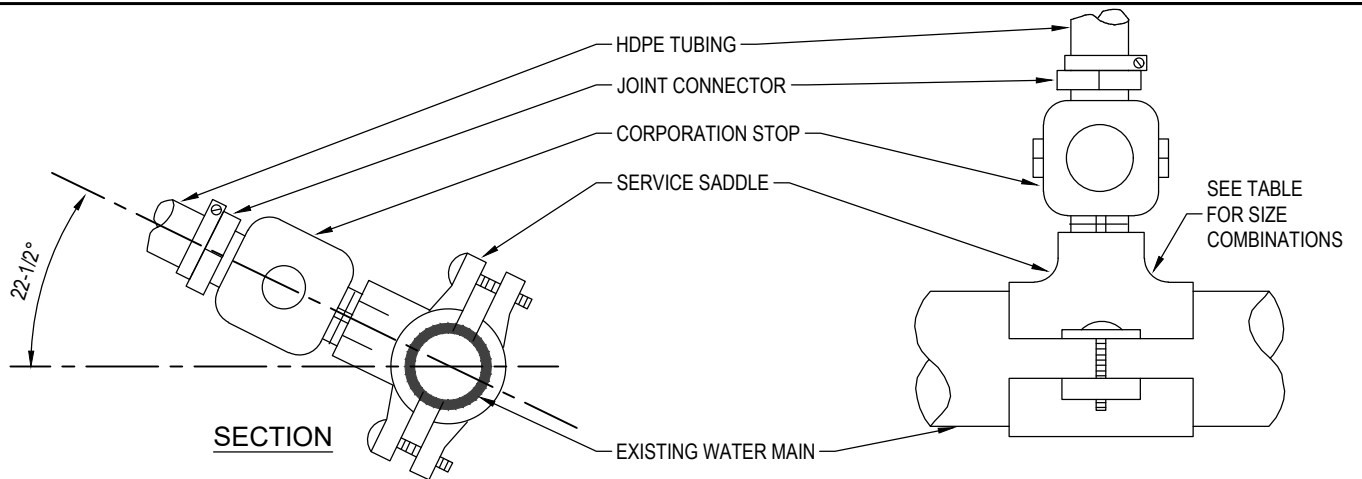

SADDLE TAP DETAIL

| PIPE | SIZE | CORP. TAP SIZE | |
|--------|------------|----------------|----|
| | | 1" | 2" |
| DI/CI | 12" | DT | DT |
| | 8" | DT | SS |
| | 6" | DT | SS |
| | 4" | SS | SS |
| PVC | 2", 2-1/2" | SS | NA |
| | 8", C-900 | SS | SS |
| | 6", C-900 | SS | SS |
| | 2"-SDR21 | SS | NA |
| OTHER* | 12" | SS | SS |
| | 10" | SS | SS |
| | 8" | SS | SS |
| | 6" | SS | SS |
| | 4" | SS | NA |
| | 3" | SS | NA |
| | 2", 2-1/2" | SS | NA |

LEGEND

DT- DIRECT TAP CAN BE ALLOWED (FOR APPROVED VARIANCES ONLY)

SS- SERVICE SADDLE IS REQUIRED

NA- NOT ALLOWED

*ASBESTOS CEMENT, STEEL, GALVANIZED IRON PIPE, NON STD PVC, ETC.



LAST REVISION
MAY 2021

TAPPING DETAIL FOR 3/4", 1",
1-1/2" & 2" W/DI, CI, OR PVC PIPE

5.01A

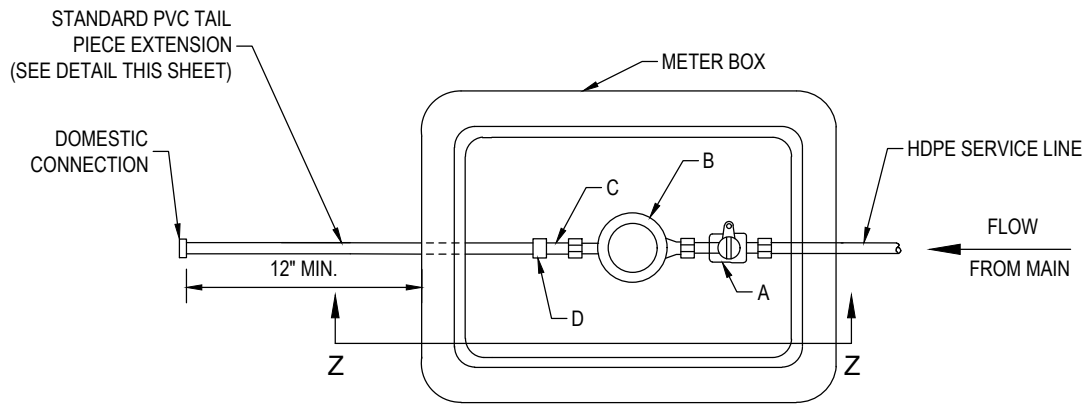

PLAN VIEW

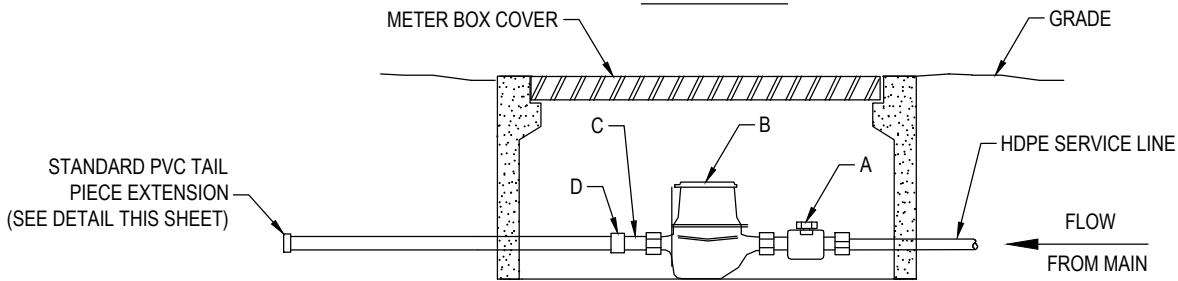

SECTION Z-Z

| METER INSTALLATION PARTS LIST | |
|-------------------------------|---|
| ITEM | DESCRIPTION |
| A | HDPE CJ X METER, SWIVEL NUT (CURB STOP) |
| B | METER |
| C | BRASS METER COUPLING |
| D | *PVC FIP X WELD COUPLING |

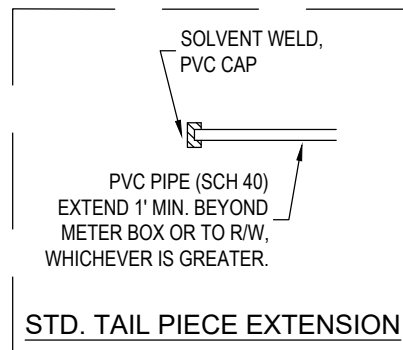

* ALL PVC PIPE AND FITTINGS SHALL BE SCH 80 EXCEPT FOR STANDARD TAIL PIECE SECTION WHICH WILL BE SCH 40.

NOTE: PARTS LIST IS FOR STANDARD INSTALLATION; ACTUAL PARTS REQUIRED MAY VARY AS DIRECTED BY THE ENGINEER.

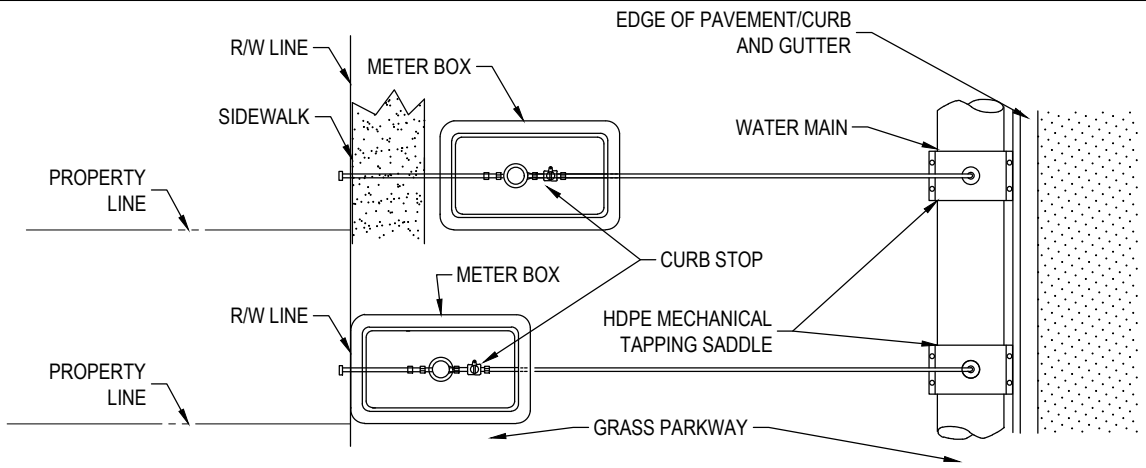

PLAN - SINGLE METER

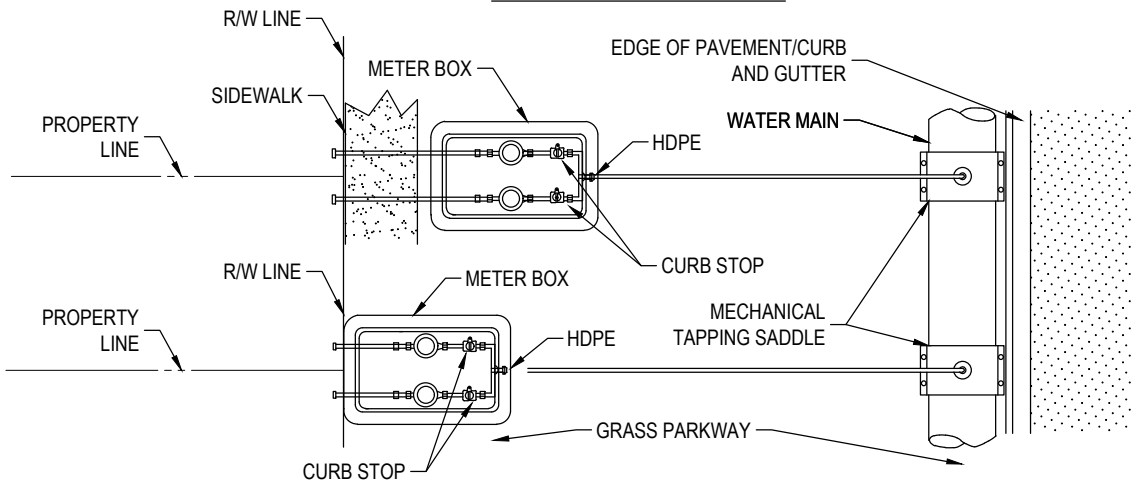

**PLAN VIEW - DUAL METER
FOR APPROVED VARIANCES**

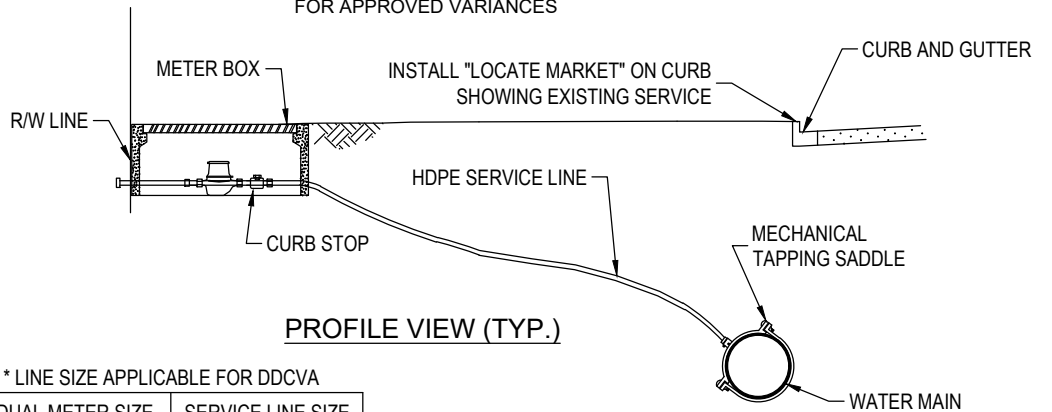

PROFILE VIEW (TYP.)

DO NOT INSTALL METER WITHIN SIDEWALK. WHEN SIDEWALK EXISTS, INSTALL METER ON STREET SIDE OF SIDEWALK OR WHERE DIRECTED BY CITY ENGINEER.

| SINGLE METER SIZE (INCHES) | SERVICE LINE SIZE (INCHES) (0-15') |
|----------------------------|------------------------------------|
| 3/4 | 1 |
| 1 | 1 |
| 1 1/2 | 2 |
| 2* | 2 |

* LINE SIZE APPLICABLE FOR DDCVA

| DUAL METER SIZE (INCHES)** | SERVICE LINE SIZE (INCHES) (0-15') |
|----------------------------|------------------------------------|
| 3/4 | 2 |
| 1 | 2 |
| 1 1/2 | N/A |
| 2* | N/A |

** FOR APPROVED VARIANCES ONLY

(FEET REFER TO DISTANCE FROM WATER MAIN TO METER)



LAST REVISION
MAY 2021

**SINGLE & DUAL METERED
SERVICE - SHORT SIDE
3/4", 1", 1-1/2" & 2"**

5.04A

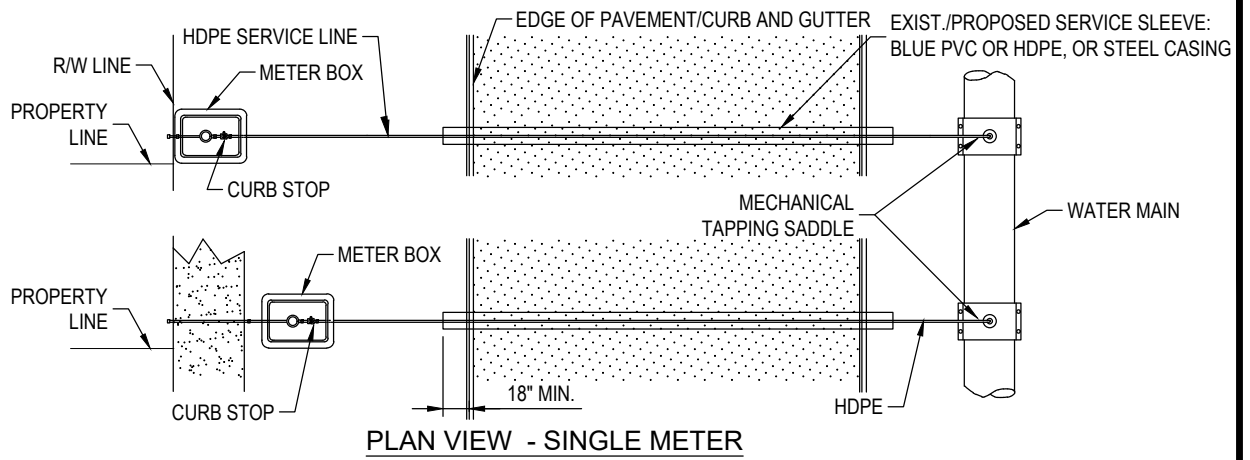

PLAN VIEW - SINGLE METER

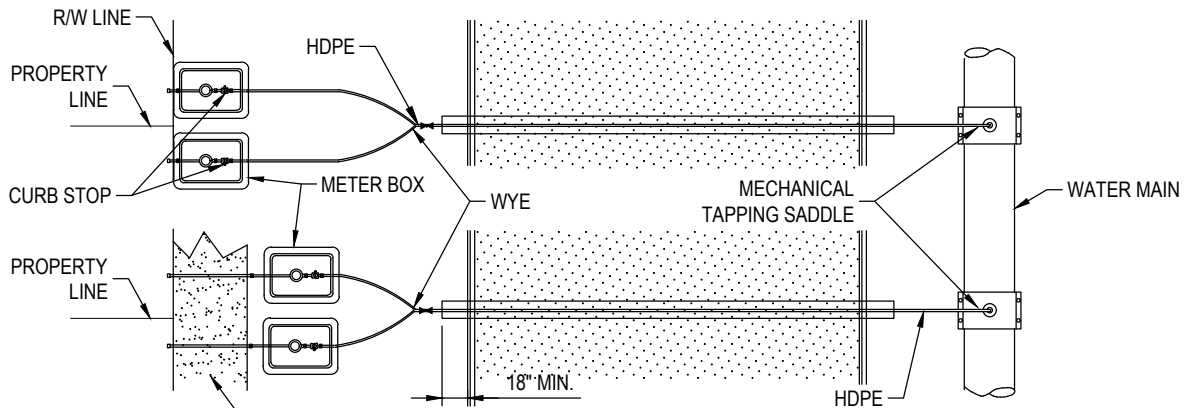

**PLAN VIEW - DUAL METER
FOR APPROVED VARIANCES**

DO NOT INSTALL METER WITHIN SIDEWALK. WHEN SIDEWALK EXISTS, INSTALL METER ON STREET SIDE OF SIDEWALK OR WHERE DIRECTED BY ENGINEER.

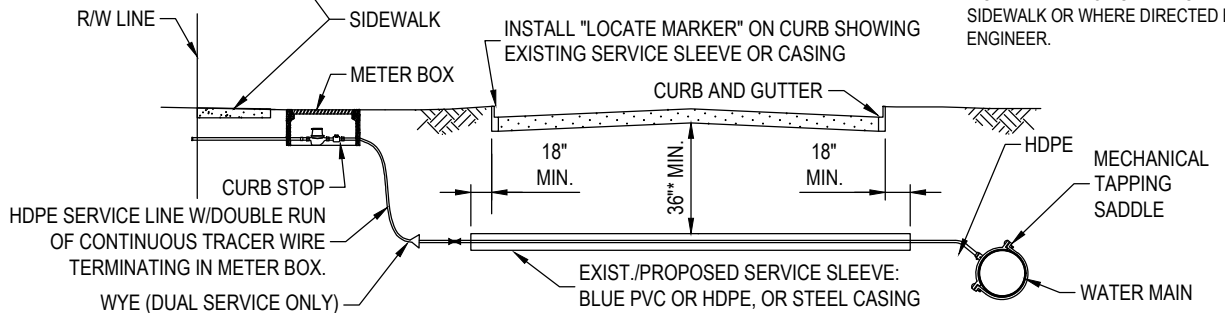

PROFILE VIEW (TYP.)

CASING SPECIFICATION:

1. IF PUSHED-SCH 40 STEEL PIPE (MIN.)
2. IF LAYED IN OPEN TRENCH-SCH 40 STEEL PIPE OR SCH 80 PVC SOLVENT WELD PIPE.
3. IF USING HDPE TUBING (UP TO 2")-SDR-9 200 PSI, TYPE III, COLOR AND UV CODE E, CLASS C, PE 4710, AWWA C-901, NSF-61, MIN. CELL CLASSIFICATION OF PE 454474 E
4. IF USING HDPE PIPE (4" OR LARGER)-DR-11 160 PSI, PE 4710, AWWA C-906, NSF-61, MIN. CELL CLASSIFICATION OF PE 454474 C. EXTERIOR COLOR TO BE SOLID BLUE OR BLACK W/BUE STRIPES (90 OR 120 DEGREES APART)

* OR GREATER, IF REQUIRED BY ROW CONTROLLING AGENCY
** LINE SIZES APPLICABLE FOR 2" DDCV

| SINGLE METER SIZE (INCHES) | SERVICE LINE SIZE (INCHES) | | CASING SIZE (INCHES) |
|----------------------------|----------------------------|------------|----------------------|
| | (15'-80') | (80'-150') | |
| 3/4 | 1 | 2 | 2 / 4 |
| 1 | 2 | 2 | 4 |
| 1 1/2 | 2 | 2 | 4 |
| 2** | 4" D.I.P. | 4" D.I.P. | 12 |

(FEET REFER TO DISTANCE FROM WATER MAIN TO METER)

| DUAL METER SIZE (INCHES)*** | SERVICE LINE SIZE (INCHES) | | CASING SIZE (INCHES) |
|-----------------------------|----------------------------|------------|----------------------|
| | (15'-80') | (80'-150') | |
| 3/4 | 2 | 2 | 4 |
| 1 | 2 | 4" D.I.P. | 4 / 12 |
| 1 1/2 | N/A | N/A | N/A |
| 2" | N/A | N/A | N/A |

*** FOR APPROVED VARIANCES ONLY



LAST REVISION
MAY 2021

**SINGLE & DUAL METERED
SERVICE - LONG SIDE
3/4", 1", 1-1/2" & 2"**

5.05A

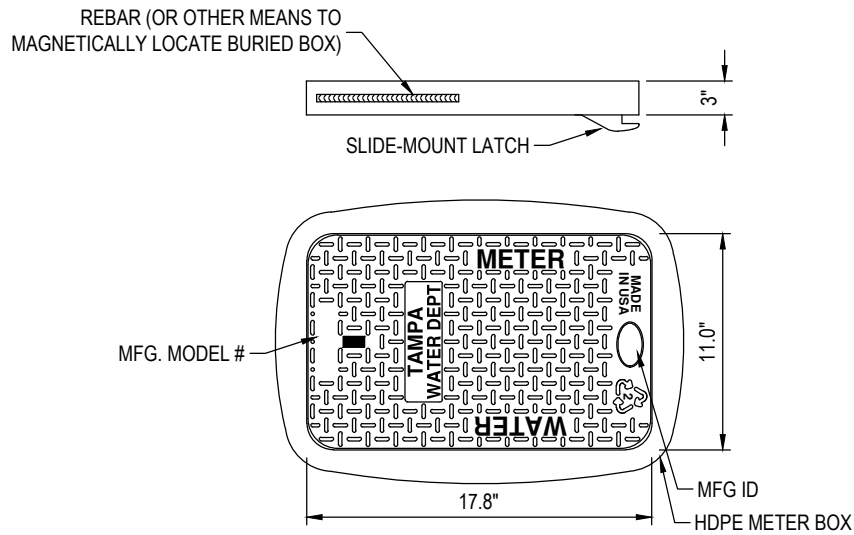

ANTI-FLOAT LID W/REBAR & AMR SNAP-LOCK SLIDE MOUNT

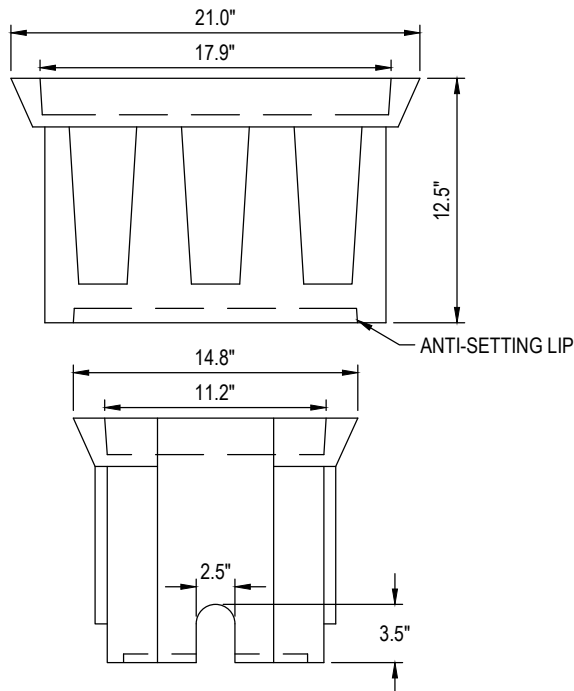

HDPE METER BOX w/LIP

#37 HDPE METER BOX W/COVER

N.T.S.



LAST REVISION
MAY 2021

3/4" OR 1" SINGLE SERVICE
HDPE METER BOX

5.10

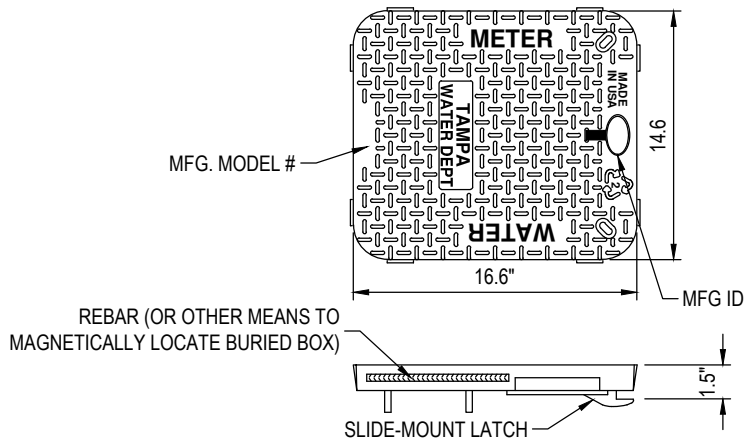

ANTI-FLOAT LID W/REBAR & AMR SNAP-LOCK SLIDE MOUNT

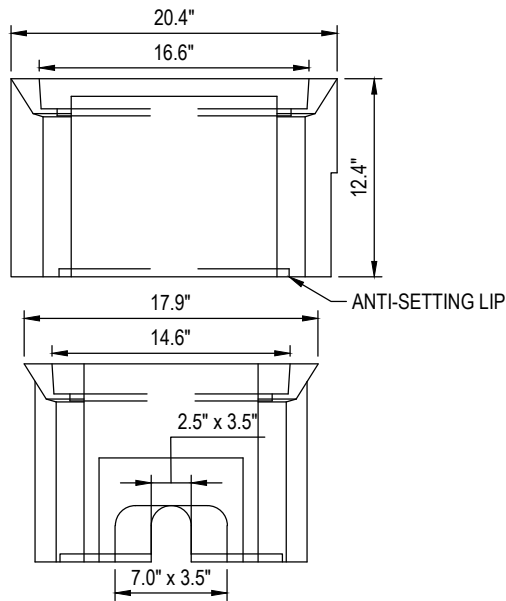

HDPE METER BOX w/LIP

"DUAL-H" HDPE METER BOX W/COVER

N.T.S.



LAST REVISION
MAY 2021

3/4" OR 1" DUAL SERVICE
HDPE METER BOX

5.11

| BODY KEY | |
|----------|-----------------------------|
| H | HEAVY WALL, $\frac{1}{2}$ " |

| LID KEY | |
|---------|---------------------|
| AF | ANTI-FLOAT MATERIAL |
| 1 | BLACK COLOR |
| M | MAGNET |
| A | AMR SLIDE MOUNT |
| TPA | TAMPA WATER |

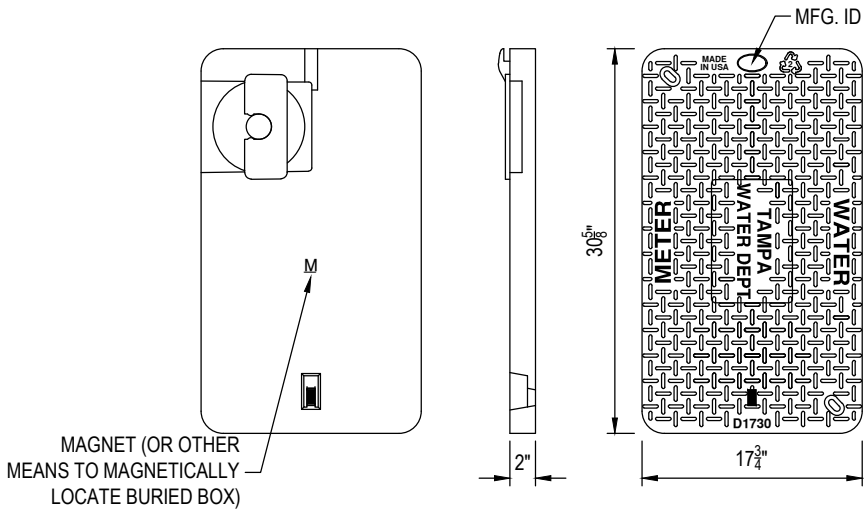

1730C-AF1MA TPA-LID

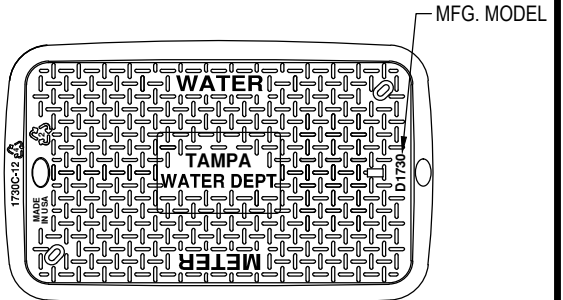

1730CH-12-AF1MA TPA

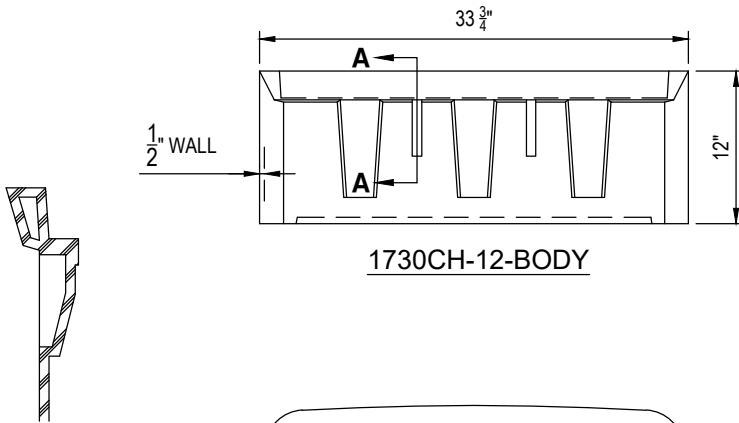

1730CH-12-BODY

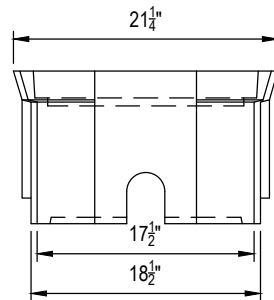

LIFT STRUCTURE SECTION A-A

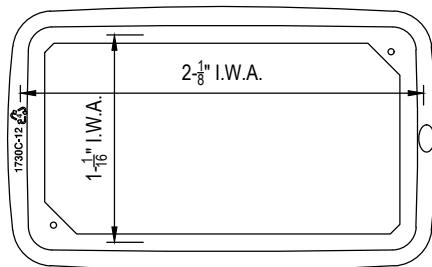

1730CH-12-BODY

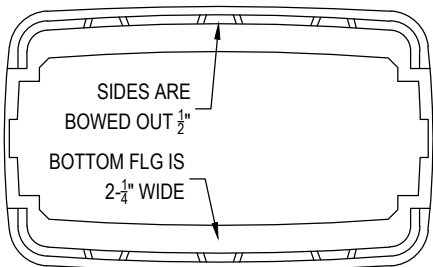

BOTTOM VIEW

NOTES

- 1) DIM'S $\pm 1/8$ " U.N.O.
- 2) LID MATERIAL: HDPE
- 3) BODY MATERIAL: LLDPE
- 4) WALL THICKNESS: $1/2$ " MINIMUM
- 5) I.W.A. = INSIDE WORK AREA.
- 6) SNAP LOCK POCKET WILL RECEIVE AMR/AMI DEVICE ENDPOINT. SNAP LOCK SLOT IS $1.80" \pm .015$ " TO ALLOW FOR A FINGER FORCE INSTALL. POCKET HEIGHT IS $15/16$ " FOR MIN $1/8$ " AIR GAP.

N.T.S.

#66 HDPE METER BOX W/COVER



LAST REVISION
MAY 2021

1-1/2" & 2" SINGLE SERVICE
HDPE METER BOX

5.12

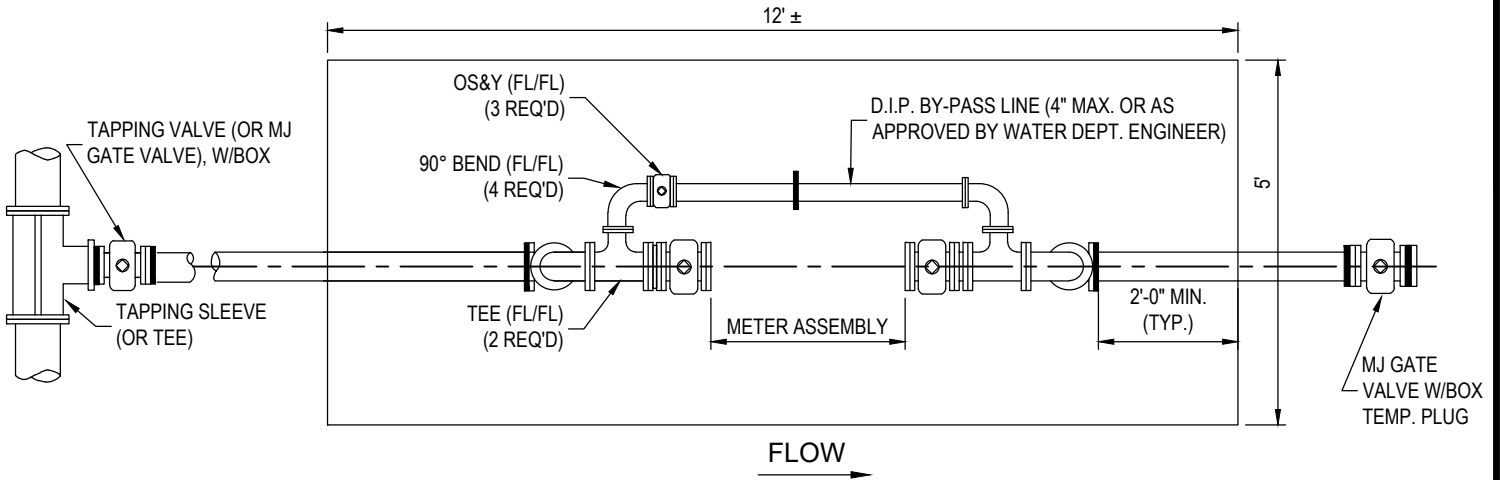

PLAN

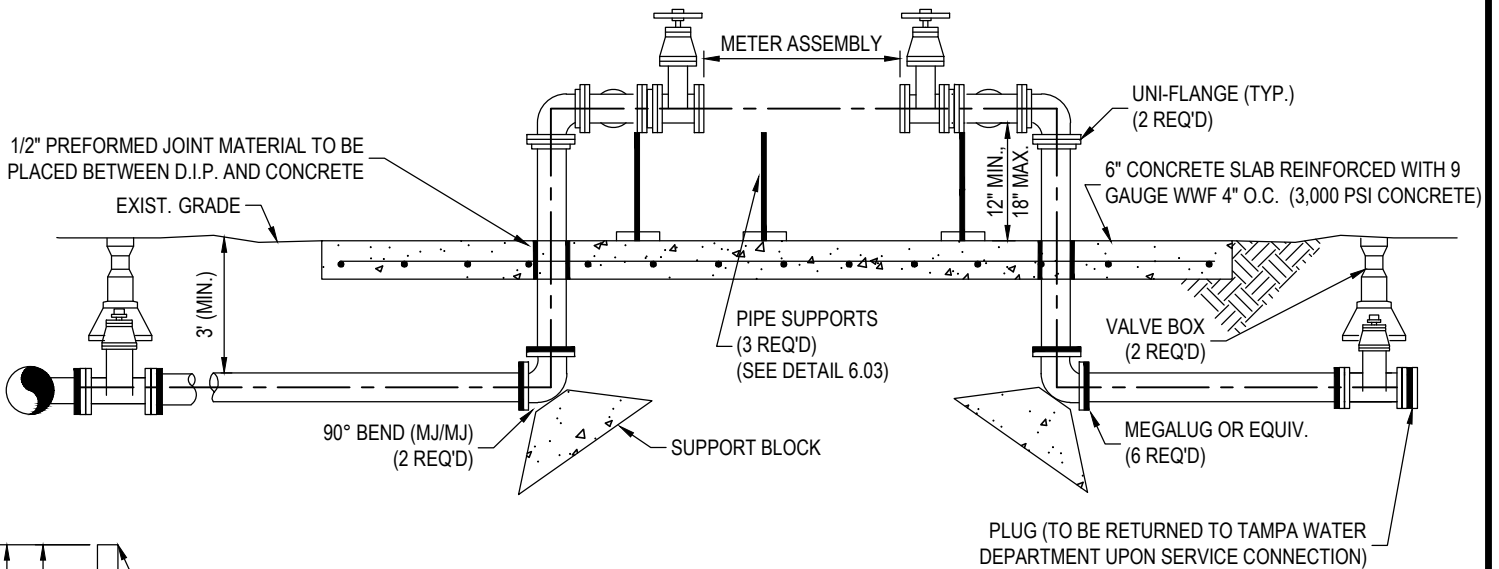

PROFILE

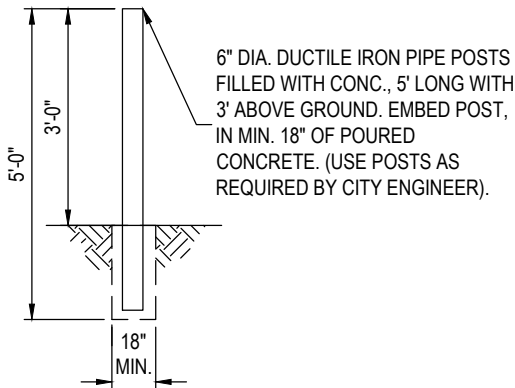

BOLLARD POST DETAIL

N.T.S.

| | | | |
|--|-----------------------------------|---|--------------|
| | <p>LAST REVISION MAY 2021</p> | <p>ABOVE GROUND LARGE METER ASSEMBLY (3" OR LARGER)</p> | <p>6.01A</p> |
|--|-----------------------------------|---|--------------|

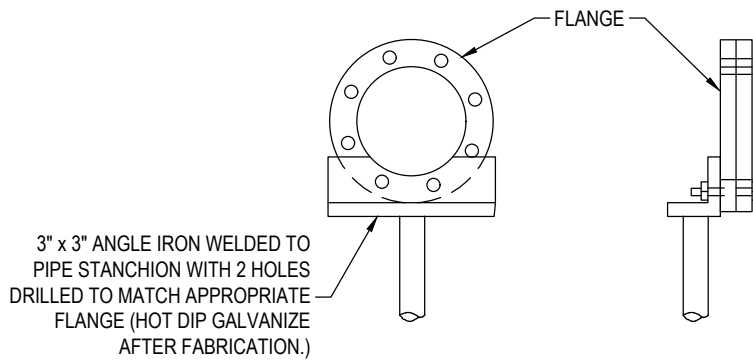
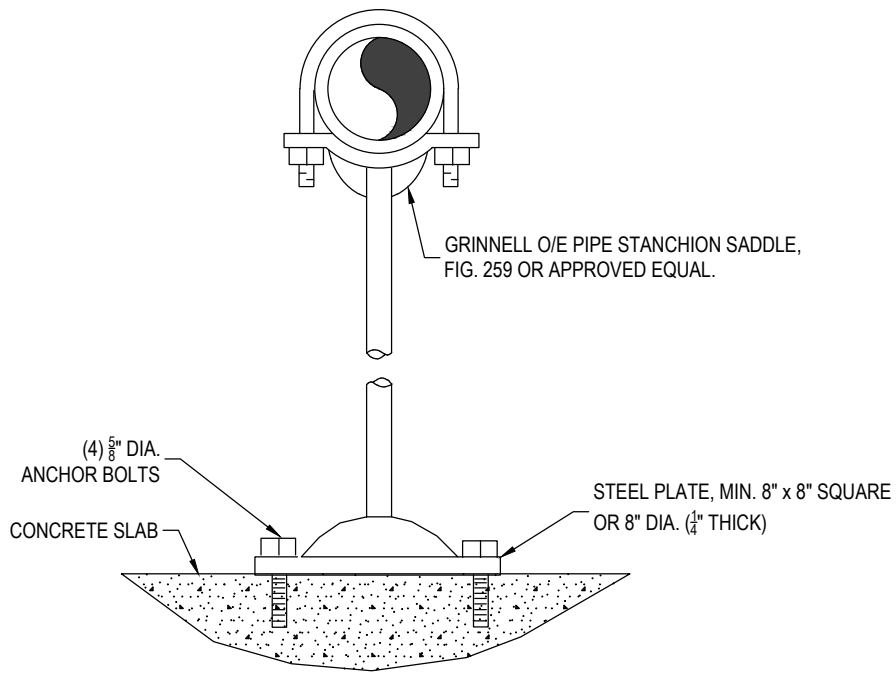

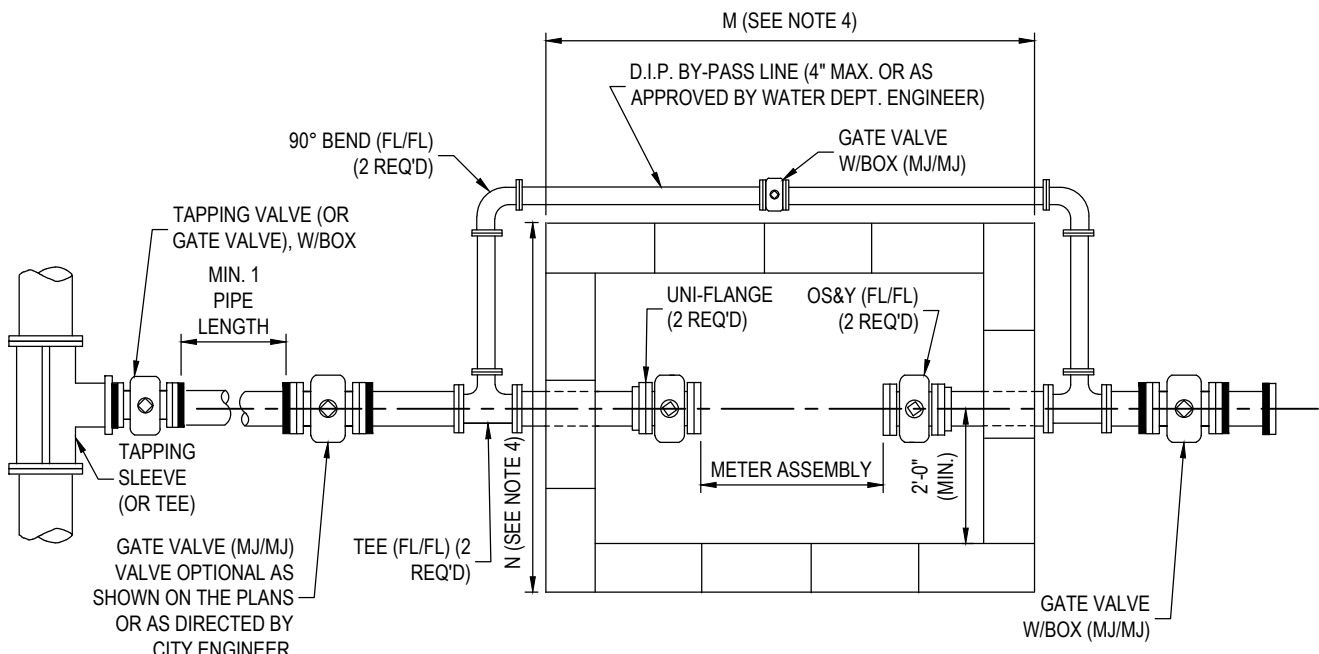

PLAN

NOTE: CONSTRUCTION OF VAULT WITHOUT METER

1. SET UNIFLANGE AT MINIMUM DISTANCE FROM WALL AND ATTACH ISOLATION VALVES.
2. SPAN DISTANCE BETWEEN ISOLATION VALVES WITH SINGLE PIECE OF PIPE.
3. TO INSTALL METER, REMOVE PIPE BETWEEN VALVES AND ATTACH METER TO ONE VALVE. PIPE SHALL BE CUT TO SIZE TO SPAN THE DISTANCE BETWEEN METER AND SECOND VALVE.
4. SEE DETAILS 6.07 & 6.08 FOR VAULT DETAILS AND DIMENSIONS.

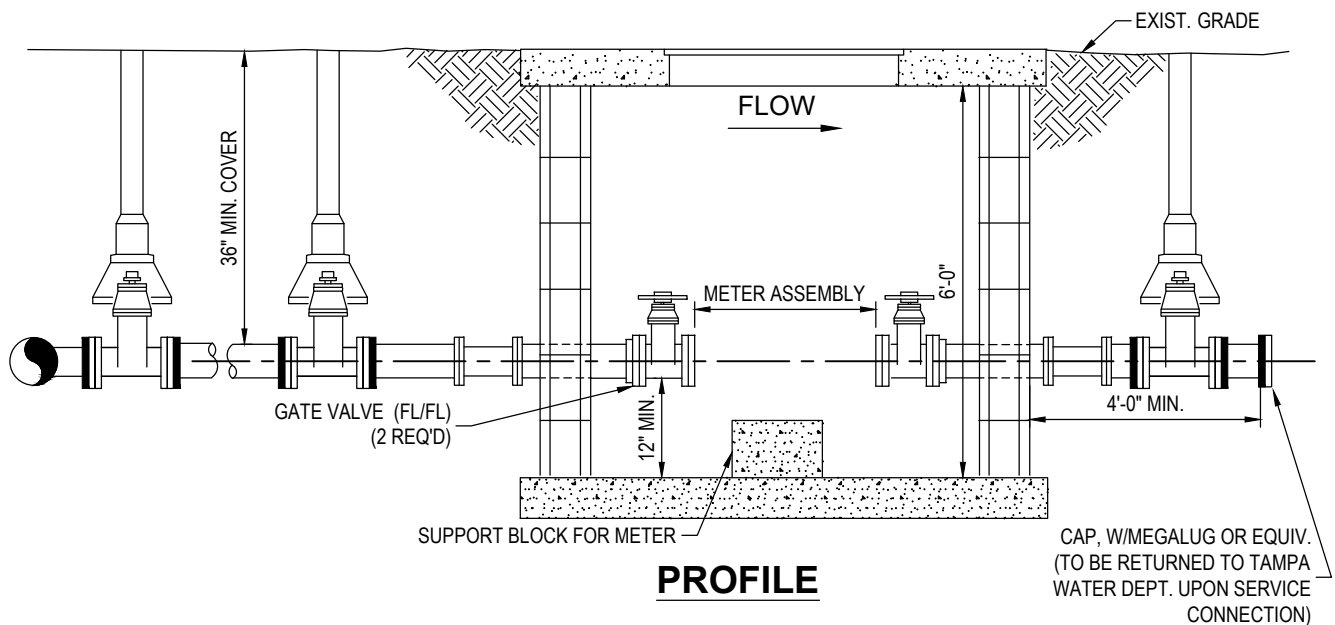

PROFILE



LAST REVISION
MAY 2021

METER IN VAULT

6.04

| METER SIZE | TOP & BOTTOM SLAB SIZE | | VAULT SIZE | |
|-----------------------------------|------------------------|--------|------------|--------|
| | K | L | M | N |
| 3" & 4" COMPOUND METER | 6'-4" | 6'-4" | 6'-0" | 6'-0" |
| 3", 4", 6", 8" METER | 8'-4" | 5'-8" | 8'-0" | 5'-4" |
| 4" DOUBLE DETECTOR CHECK | 6'-4" | 6'-4" | 6'-0" | 6'-0" |
| 6" DOUBLE DETECTOR CHECK | 8'-4" | 5'-8" | 8'-0" | 5'-4" |
| 8" DOUBLE DETECTOR CHECK | 9'-8" | 8'-4" | 9'-4" | 8'-0" |
| 10" DOUBLE DETECTOR CHECK | 11'-0" | 8'-4" | 10'-8" | 8'-0" |
| 4", 6", 8" DDCV & ≥ 3" DOM. METER | 8'-4" | 9'-8" | 8'-0" | 9'-4" |
| 10" DDCV & ≥ 3" DOM. METER | 8'-4" | 11'-0" | 8'-0" | 10'-8" |

NOTE: VAULT AND SLAB SIZES MAY VARY AS DIRECTED BY THE CITY ENGINEER.

VAULT DIMENSIONS

ALL CONCRETE POURED INTO CELLS SHALL BE A MIN. OF 3,000 P.S.I. STRENGTH

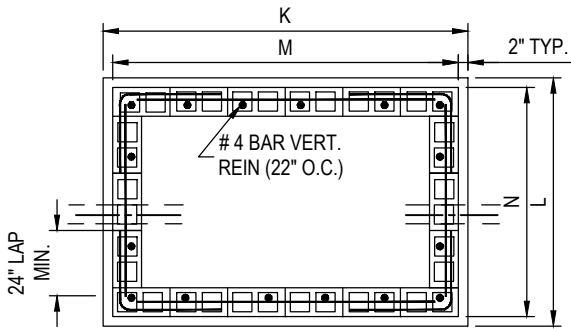

NOTE: BITUMINOUS TYPE MATERIAL (1/2" PREFORMED JOINT MATERIAL, TAR PAPER) IS TO BE PLACED BETWEEN PRE-CAST SLAB AND ANY CONCRETE SURFACES WHEN INSTALLED IN SAME

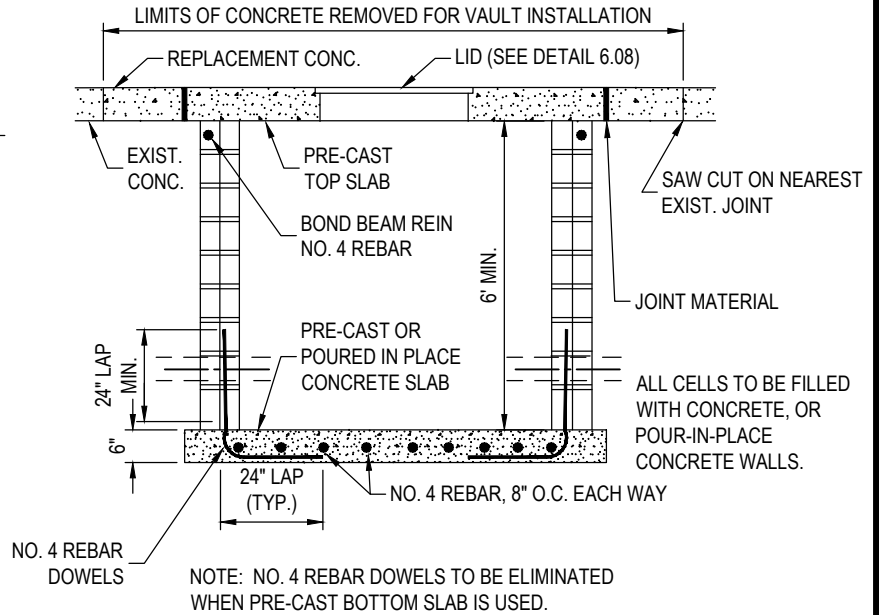

NOTE: NO. 4 REBAR DOWELS TO BE ELIMINATED WHEN PRE-CAST BOTTOM SLAB IS USED.

| SLAB SIZE | | | REBAR | | | |
|--------------------|-------|----|-------|---------|-------|---------|
| K | L | T | K | | L | |
| | | | SIZE | SPACING | SIZE | SPACING |
| TOP SLAB | | | | | | |
| 6'-4" | 6'-4" | 6" | NO. 6 | 7-1/2" | NO. 6 | 7-1/2" |
| 6'-4" | 5'-8" | 6" | NO. 6 | 5-1/4" | NO. 6 | 8-1/2" |
| 9'-8" | 8'-4" | 8" | NO. 6 | 5-1/8" | NO. 6 | 6" |
| 11'-0" | 8'-4" | 8" | NO. 6 | 5-1/8" | NO. 6 | 6" |
| BOTTOM SLAB | | | | | | |
| 6'-4" | 6'-4" | 6" | NO. 4 | 8" | NO. 4 | 8" |
| 6'-4" | 5'-8" | 6" | NO. 4 | 8" | NO. 4 | 8" |
| 9'-8" | 8'-4" | 8" | NO. 4 | 8" | NO. 4 | 8" |
| 11'-0" | 8'-4" | 8" | NO. 4 | 8" | NO. 4 | 8" |

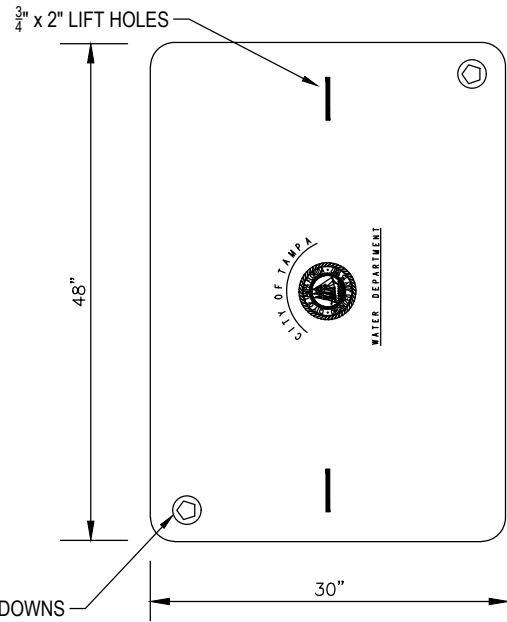

POLYMER CONCRETE COVER

CONCRETE - 4,500 PSI 28 DAY STRENGTH
 STEEL - 60 PSI YIELD STRENGTH

1/2" PENTA HEAD BOLT DOWNS

NOTE: SLAB SIZE MAY VARY AS
 DETERMINED BY CITY ENGINEER.

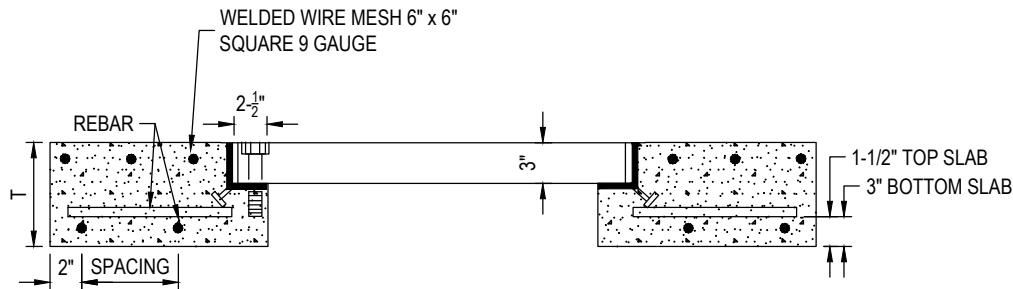

CROSS SECTION A-A

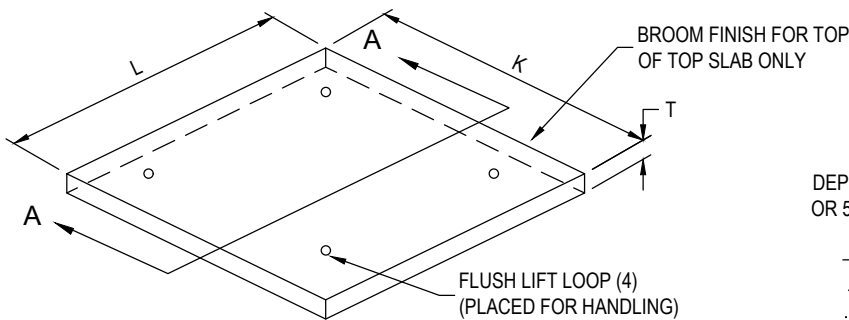

SLAB ISOMETRIC

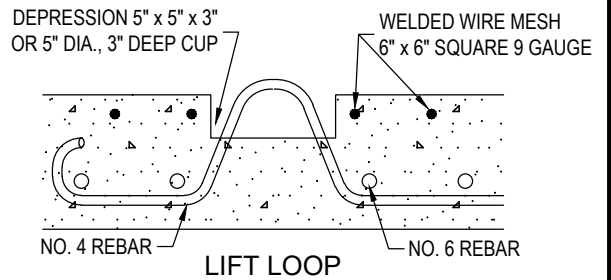

LIFT LOOP

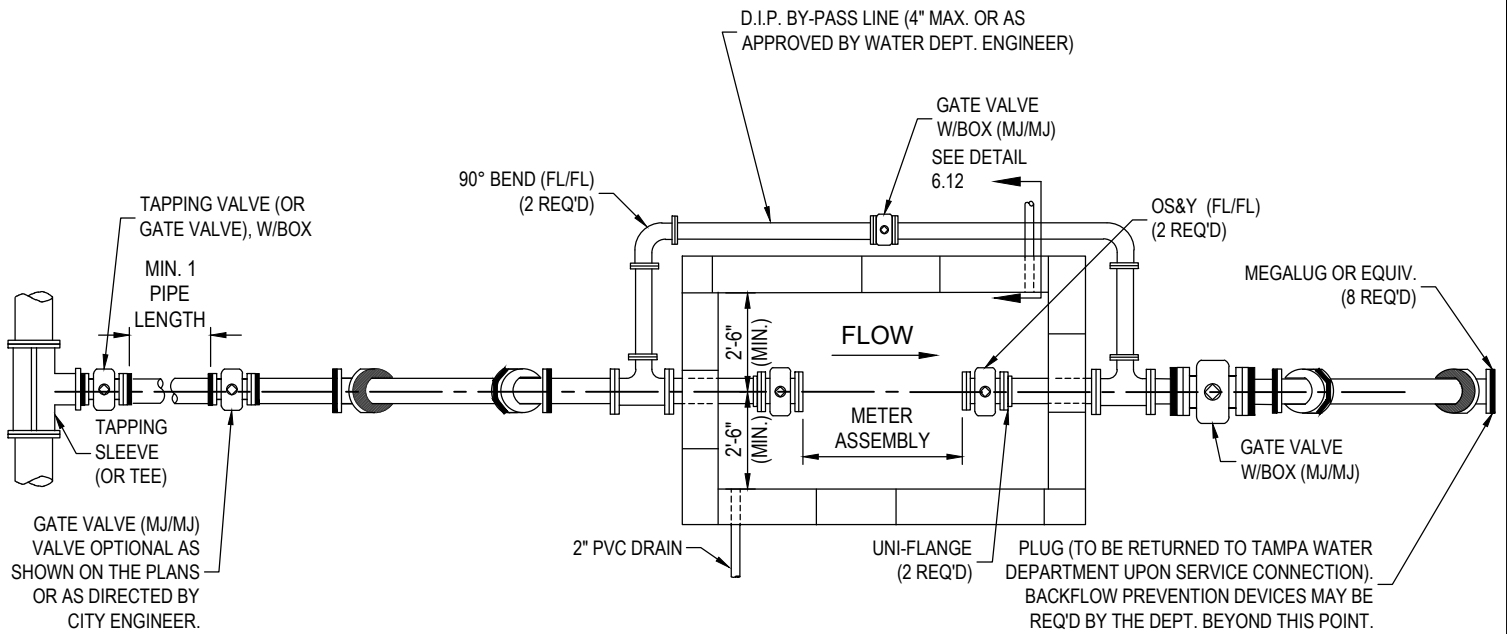

PLAN

NOTES:

1. SEE DETAIL 6.12 FOR ABOVE GROUND VAULT DETAILS
2. MINIMUM CLEARANCE FOR ALL INTERNAL AND EXTERNAL FITTINGS SHALL BE 8" FROM ALL WALLS

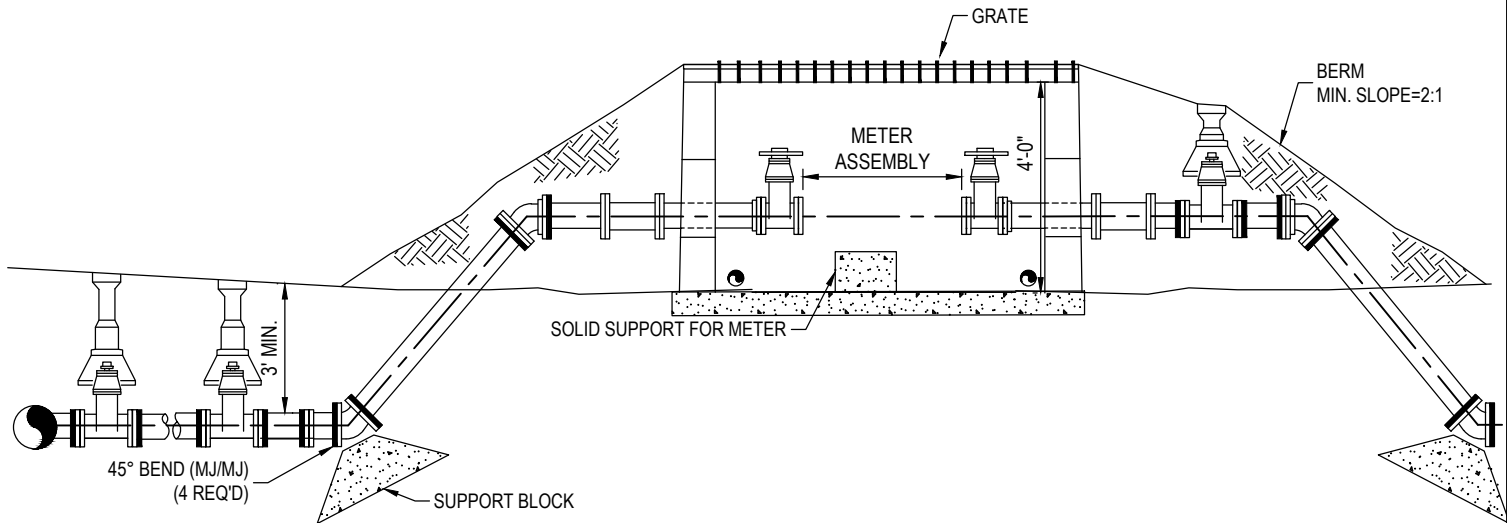

PROFILE

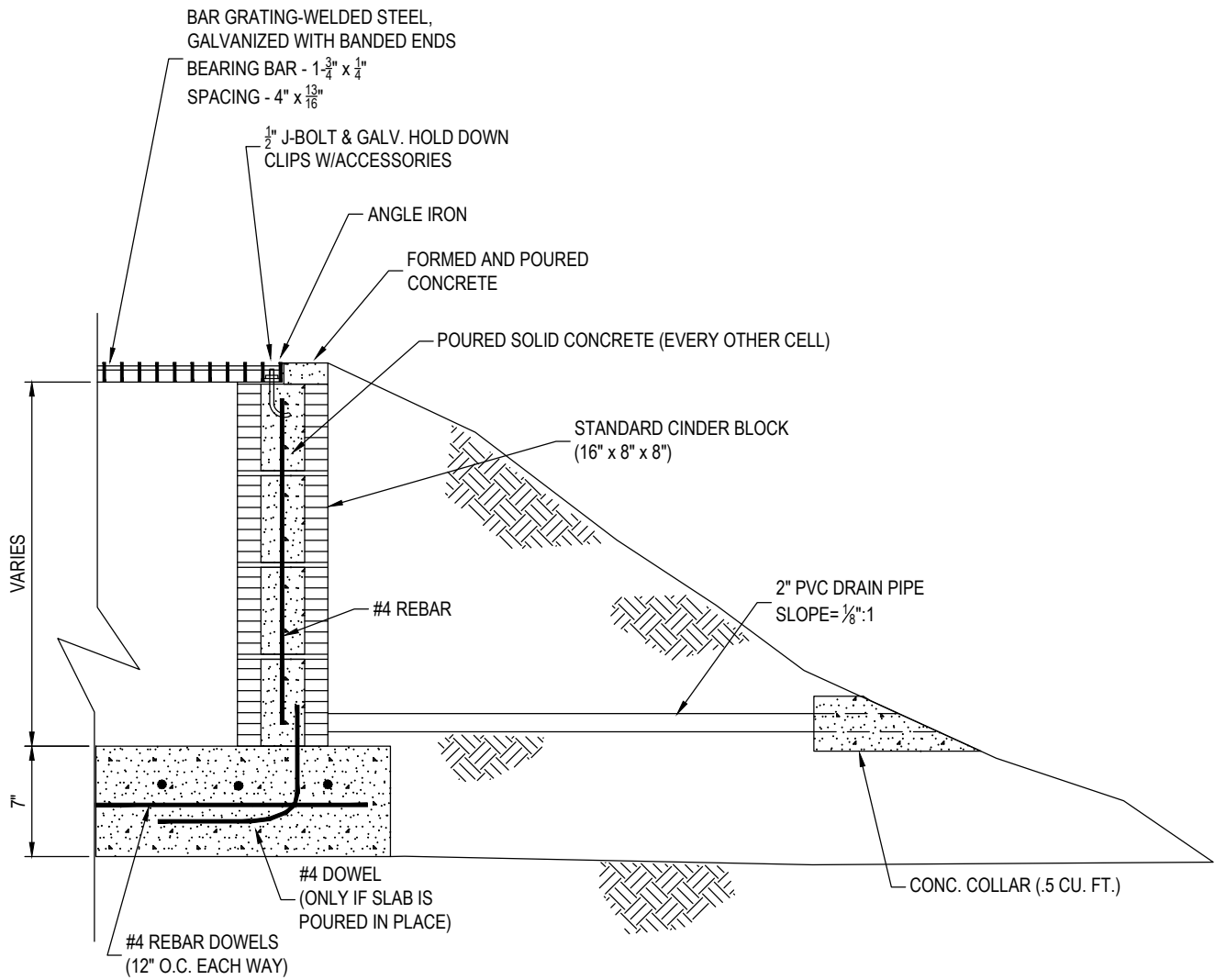

TYPICAL CROSS SECTION DETAIL

NOTE: ALL CONCRETE SHALL HAVE A MIN. COMPRESSIVE STRENGTH OF 3000 PSI IN 28 DAYS.

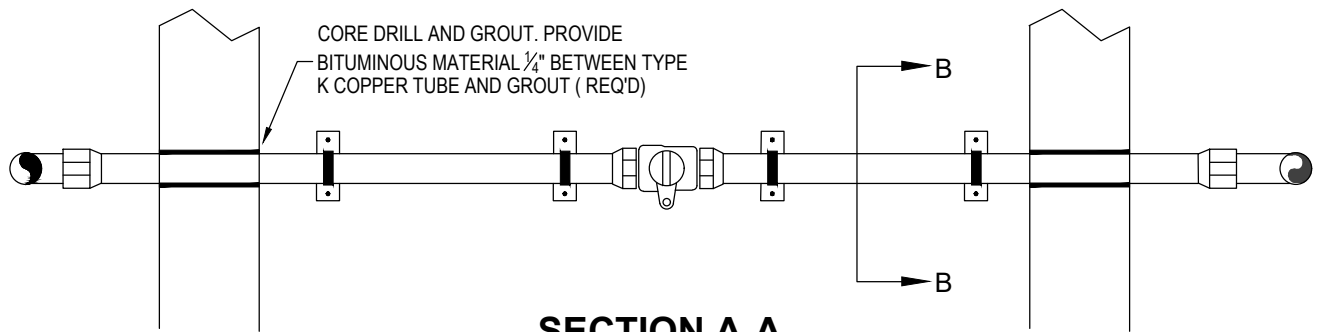
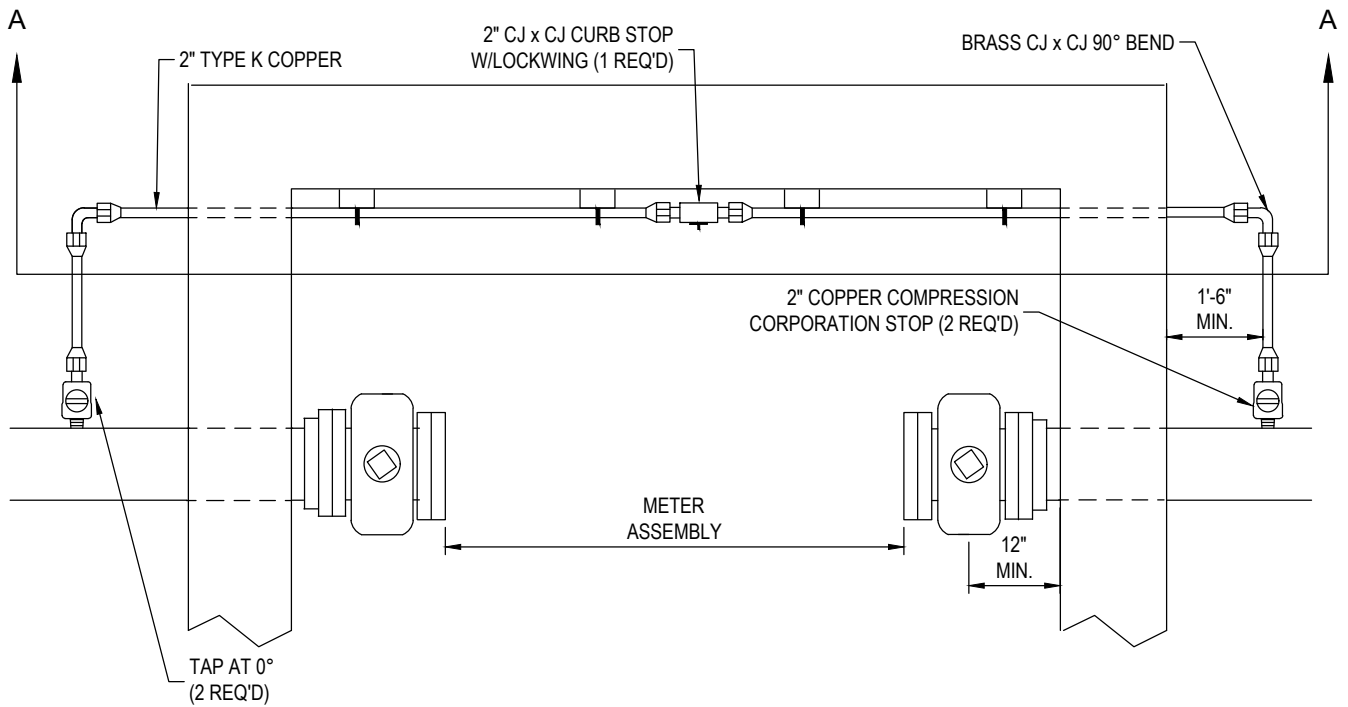

SECTION A-A

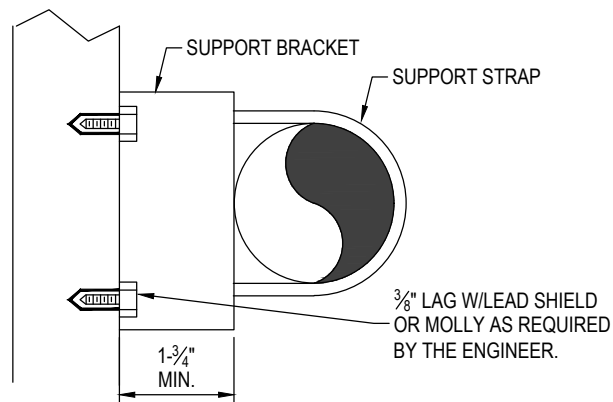

SECTION B-B

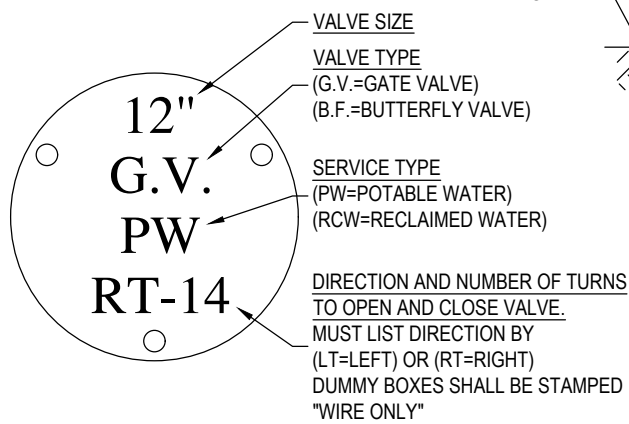
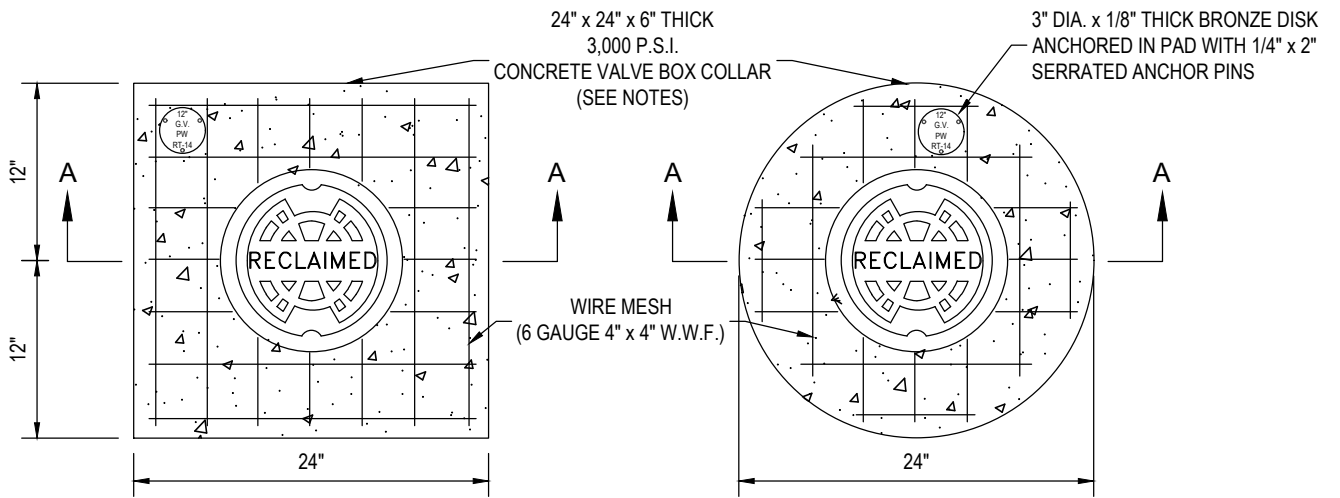

BRONZE DISK DETAIL

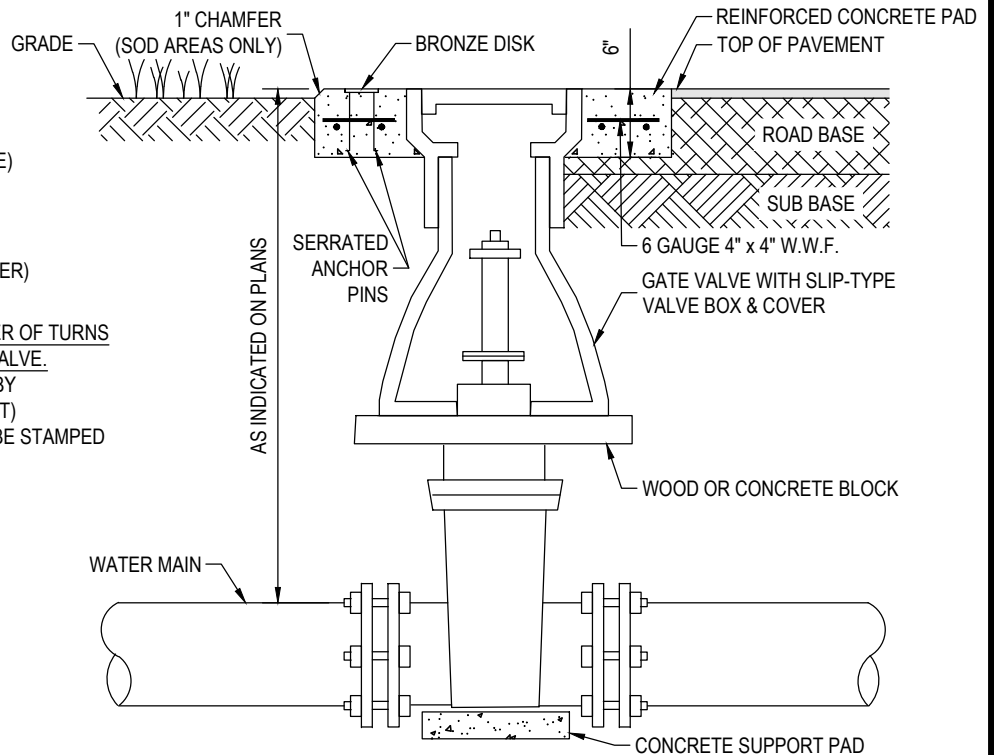

SECTION A-A

NOTES :

1. CIRCULAR OR SQUARE CONCRETE PAD REQUIRED FOR ALL VALVE BOX INSTALLATIONS IN PVIOUS AREAS (I.E. OUTSIDE OF ROADWAY PAVEMENT, OUTSIDE OF CONCRETE/ASPHALT DRIVEWAYS, ETC.)
2. CAST IRON VALVE BOXES SHALL BE FIRMLY SUPPORTED AND CENTERED AND PLUMB OVER THE OPERATING NUT OF THE VALVE. VALVE BOX COVER SHALL BE FLUSH WITH THE SURFACE OF THE FINISHED PAVEMENT, OR GRADE OR AT SUCH OTHER LEVEL AS MAY BE DIRECTED BY THE DEPARTMENT.
3. "BLUE" WATER VALVE LOCATE MARKERS REQUIRED FOR ALL VALVE INSTALLATIONS.
4. EMBED BRONZE VALVE INFO DISK INTO CONCRETE VALVE BOX COLLAR.
5. ALL MATERIALS SHALL BE IN ACCORDANCE WITH THE LATEST T.W.D. APPROVED MATERIAL SPECIFICATIONS.
6. IF VALVE IS LOCATED WITHIN A SIDEWALK CONCRETE COLLAR MAY BE ELIMINATED AND DISK SET FLUSH DIRECTLY IN SIDEWALK.
7. BRONZE DISK REQUIRED FOR ALL VALVES AND DUMMY BOXES.

| | | | |
|--|-----------------------------------|---|--------------|
| | <p>LAST REVISION MAY 2021</p> | <p>VALVE INSTALLATION W/VALVE BOX & PAD FOR DI OR CI PIPE - RECLAIMED</p> | <p>7.01R</p> |
|--|-----------------------------------|---|--------------|

| BODY KEY | |
|----------|-----------------------------|
| H | HEAVY WALL, $\frac{1}{2}$ " |

| LID KEY | |
|---------|---------------------|
| AF | ANTI-FLOAT MATERIAL |
| 5 | PURPLE COLOR |
| M | MAGNET |
| A | AMR SLIDE MOUNT |
| TPA | TAMPA WATER |

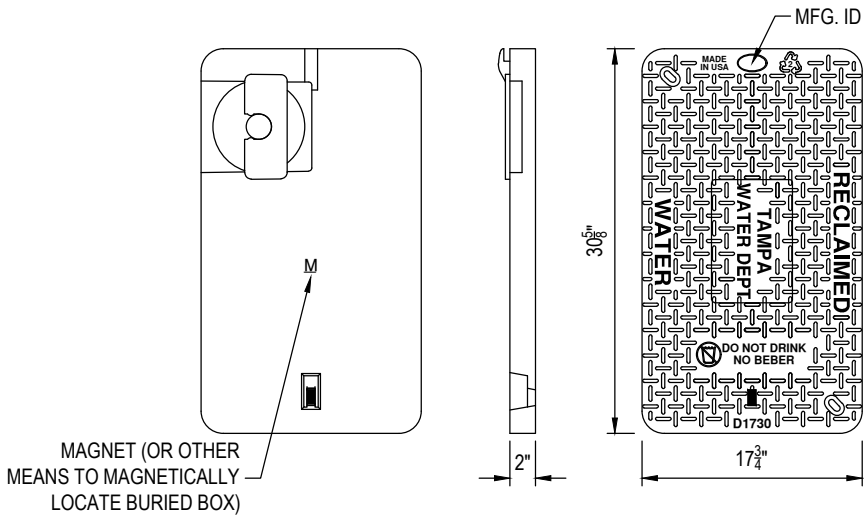

1730C-AF5MA TPA-LID

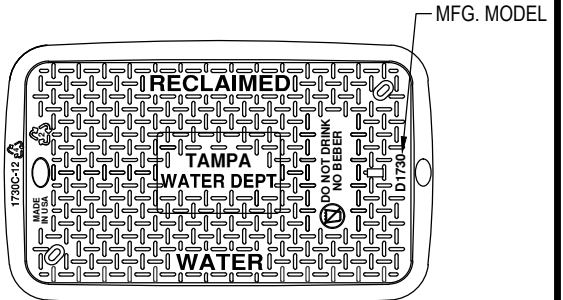

1730CH5-12-AF5 MA TPA

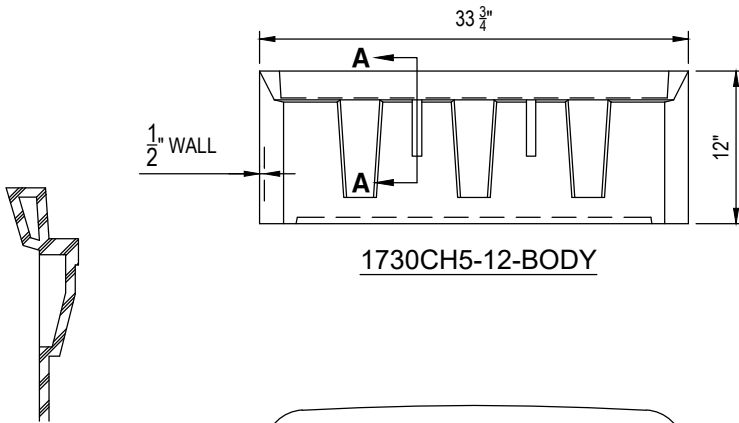

1730CH5-12-BODY

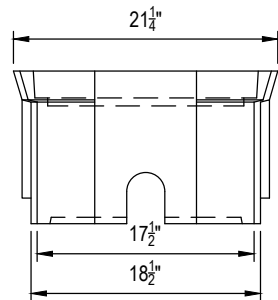

LIFT STRUCTURE SECTION A-A

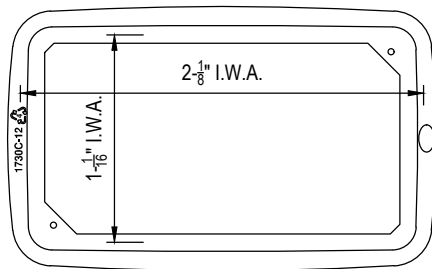

1730CH5-12-BODY

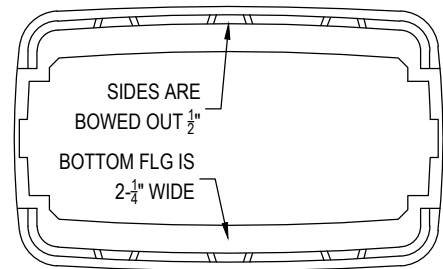

BOTTOM VIEW

NOTES

- 1) DIM'S $\pm 1/8$ " U.N.O.
- 2) LID MATERIAL: HDPE
- 3) BODY MATERIAL: LLDPE
- 4) WALL THICKNESS: $1/2$ " MINIMUM
- 5) I.W.A. = INSIDE WORK AREA.
- 6) SNAP LOCK POCKET WILL RECEIVE AMR/AMI DEVICE ENDPOINT. SNAP LOCK SLOT IS $1.80" \pm .015"$ TO ALLOW FOR A FINGER FORCE INSTALL. POCKET HEIGHT IS $15/16"$ FOR MIN $1/8"$ AIR GAP.

#66 HDPE METER BOX W/COVER

N.T.S.



LAST REVISION
MAY 2021

1-1/2" & 2" SINGLE SERVICE
HDPE METER BOX - RECLAIMED

7.02R

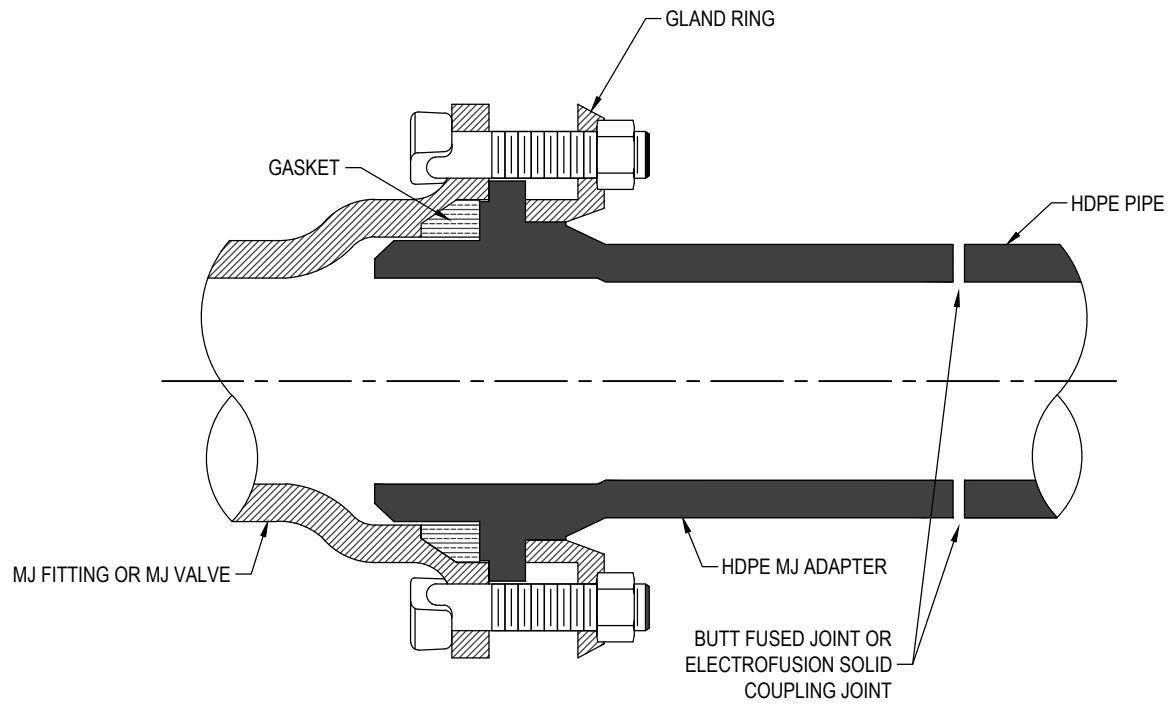

NOTES:

1. SCHEMATIC SHOWN FOR STANDARD MJ FITTINGS AND GATE VALVES.
2. BOLT LENGTH SIZED TO ACCOMODATE GLAND RING, MJ ADAPTOR AND MJ FITTING ON MJ VALVE.

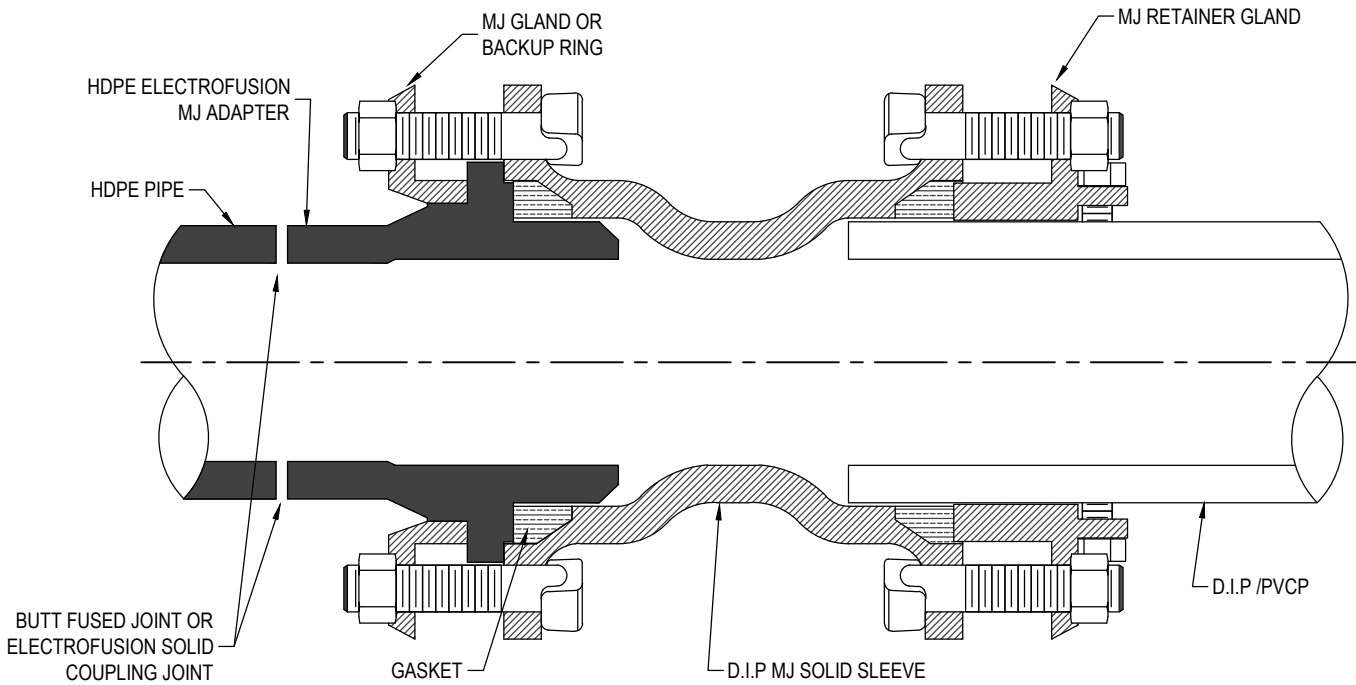

NOTES:

1. SCHEMATIC SHOWN FOR STANDARD MJ FITTINGS AND GATE VALVES.
2. BOLT LENGTH SIZED TO ACCOMODATE GLAND RING, MJ ADAPTOR AND MJ FITTING ON MJ VALVE.

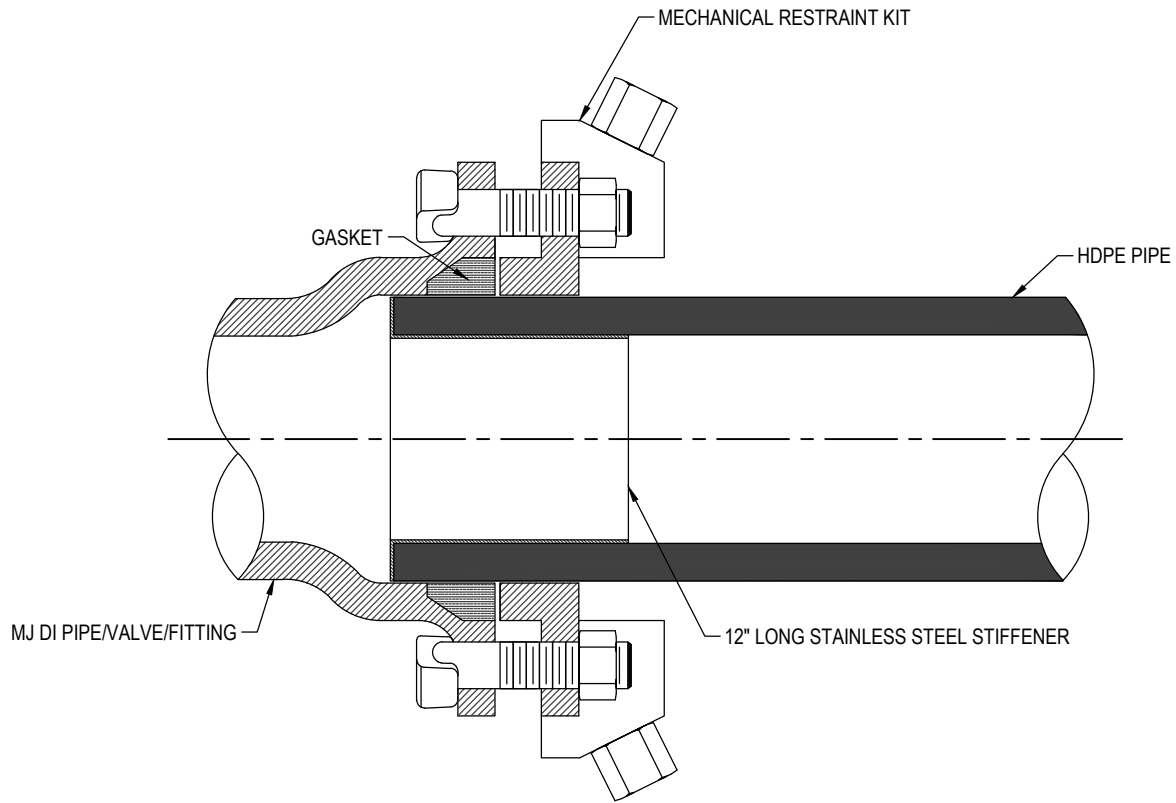

NOTES:

1. MECHANICAL FITTINGS SHALL BE SPECIFICALLY DESIGNED FOR USE WITH HDPE PIPE.
2. INTERNAL STIFFENER SHALL BE SOLID BODY TYPE. STIFFENER WILL BE RATED FOR DR AND ID AS PER PIPE MANUFACTURER. STIFFENER SHALL BE ASTM 240, TYPE 304 STAINLESS STEEL, 17 GAUGE, UNLESS OTHERWISE DIRECTED BY ENGINEER.