



CITY OF TAMPA

Bob Buckhorn, Mayor

CONTRACT ADMINISTRATION DEPARTMENT

David L. Vaughn, AIA, Director

ADDENDUM NO. 2

DATE: April 13, 2015

Contract 14-C-00054; Blue Sink Water Main

Bidders on the above referenced project are hereby notified that the following addendum is made to the Contract Documents. BIDS TO BE SUBMITTED SHALL CONFORM TO THIS NOTICE.

- Item 1: Change, on page I-1a, in I-1.05, the time for completion to be 270 days.
- Item 2: Replace Proposal pages P-3, P-4 and P-5 with the attached pages P-3R, P-4R and P-5R (attached Tab Revised 4.9.15).
- Item 3: Replace Plan Sheets 6-11 with the attached Plan Sheets 6-11 Revised 4.9.15.
- Item 4: Replace Plan Sheet 31A with the attached Plan Sheet 31A Revised 4.9.15.
- Item 5: Replace Plan Sheet 20 with the attached Plan Sheet 20 Revised 4.9.15.
- Item 6: Replace Plan Sheet 2 with the attached Plan Sheet 2 Revised 4.9.15.
- Item 7: Replace the Contract Pay Items with the attached Contract Pay Items Revised 4.9.15.
- Item 8: Attached for reference are the Curiosity Creek As-built drawings.
- Item 9: Attached for reference is the geotechnical report.

All other provisions of the Contract Documents and Specifications not in conflict with this Addendum shall remain in full force and effect. Questions are to be e-mailed to Contract Administration@tampagov.net.

Jim Greiner

Jim Greiner, P.E., Contract Management Supervisor

Item No.	Description	Unit	Approx. Quantity	Unit Price in Words	Unit Price	Total Computed Price
2101	F&I 16" ductile iron with more than 5' trench	LF	17,530		\$	\$
2102	F&I 30" ductile iron with more than 5' trench	LF	9		\$	\$
2103	F&I 30" Fabricated DI Flanged Pipe with 6" Flanged Outlet	EA	1		\$	\$
2201	Furnish & install 24" OD steel casing pipe	LF	392		\$	\$
3001	F&I 16" wedge-action or flange restraint	EA	206		\$	\$
3002	F&I 30" wedge-action or flange restraint	EA	6		\$	\$
3003	Furnish 16" push-on restraint gaskets	EA	260		\$	\$
4001	F&I 16" bends, offset, sleeves or reducers with DIP or DIP	EA	100		\$	\$
4002	F&I 30" bends, offsets, sleeves or reducers w/ DIP or CIP	EA	1		\$	\$
4003	F&I 30" ductile iron tee w/ DIP or CIP	EA	1		\$	\$
5001	F&I 16" Gate valve with box on DIP or CIP	EA	3		\$	\$
5002	F&I 30" butterfly valve with box on DIP or CIP	EA	1		\$	\$
6001	F&I 2" Air Vacuum Air Release Valve new 16" pipe	EA	12		\$	\$
6002	F&I 2" Air Vacuum Air Release Valve existing 30" pipe	EA	2		\$	\$
6003	F&I 3" Air Vacuum Air Release Valve	EA	2		\$	\$
6004	F&I 6" Air Vacuum Air Release Valve	EA	1		\$	\$
7101	Furnish, place and compact limerock\	CY	3,523		\$	\$

Item No.	Description	Unit	Approx. Quantity	Unit Price in Words	Unit Price	Total Computed Price
7102	Furnish and install asphalt concrete surface Type S-1	SY-IN	30,940		\$	\$
7103	Furnish, place, grade and compact Type SIII asphaltic concrete overlay	SY-IN	62,645		\$	\$
7104	Mobilization to perform mechanical milling	EA	3		\$	\$
7105	Mechanical milling of asphalt roadways in 1-inch increments	SY-IN	18,133		\$	\$
7106A	Furnish and install specialty driveway	SY	50		\$	\$
7106	Restore 6" thick concrete driveway	SY	2,320		\$	\$
7107A	Furnish and Install Brick Driveway	SY	100		\$	\$
7107	Furnish materials & Install Signalization loops	EA	1		\$	\$
7108	Furnish and install Work Zone Signs	EA	100,000		\$	\$
7111	Furnish and install Barricades (Temporary - Type II)	ED	100,000		\$	\$
7112	Furnish and install Barricades (Temporary Type III) (6')	ED	100,000		\$	\$
7113	Furnish and install Advance Warning Arrow Panel	ED	1,000		\$	\$
7114	Furnish and install High Intensity Flashing Lights (Temporary-Type B)	ED	20,000		\$	\$
7115	Furnish and install Variable Message Sign (Temporary)	ED	1,000		\$	\$
7116	Furnish and Install Concrete Barriers	EA	100		\$	\$
7205	Furnish and Install 4' Thick Concrete Sidewalk	SY	850		\$	\$
7201	Grade and sod roadside, ditch bottoms and sides	SY	3,609		\$	\$

Item No.	Description	Unit	Approx. Quantity	Unit Price in Words	Unit Price	Total Computed Price
7202	Furnish and install Type "D" concrete curb	LF	1,000		\$	\$
7204	Furnish and Install Asphalt Curb	LF	1,000		\$	\$
7206	Furnish and Install Type "F" Curb	LF	500		\$	\$
7203	Video photography	LF	17,530		\$	\$
8000	Furnish and Install new project signs	EA	4		\$	\$
9000	Contingency allowance to be use as directed by the Engineer	EA	1	Three Hundred Thousand Dollars and No Cents	\$ 300,000.00	\$ 300,000.00
	Mobilization	LS	1	One Hundred Fifty Thousand Dollars and No Cents	\$ 150,000.00	\$ 150,000.00
					TOTAL \$	

MSS-1:
Rim = 26.00
N. Invert = 19.64 (10" VCP)
S. Invert = 18.30 (8" VCP)
W. & E. Invert = 15.65 (24")

MSS-2:
Rim = 27.00
N. & S. Invert = 20.37 (10" VCP)

MSS-3:
Rim = 28.50
N. & S. Invert = 21.19 (10" VCP)

SG-1:
Grate = 25.50
E. Invert = 19.30 (15" RCP)

SG-2:
Grate = 25.50
W. Invert = 19.15 (15" RCP)
E. Invert = 19.15 (18" RCP)

SG-3:
Grate = 27.63
NE. Invert = 24.00 (12"x18" RCP)

SG-4:
Grate = 27.35
E. Invert = 24.00 (15" RCP)

SG-5:
Grate = 27.75
SW. Invert = 24.00 (15" RCP)

MST-1:
Rim = 25.70
E. Invert = 22.05 (24" RCP)
W. Invert = 22.05 (18" RCP)

MST-2:
Rim = 28.25
E. Invert = 22.64 (30" RCP)
W. Invert = 23.95 (18" RCP)
N. Invert = 23.16 (24" RCP)

MST-3:
Rim = 25.70
E. & W. Invert = 23.21 (15" RCP)
N. & S. Invert = 23.16 (24" RCP)

BROOKS

STREET

North
SEC. 19 & 30-T28S-R19E

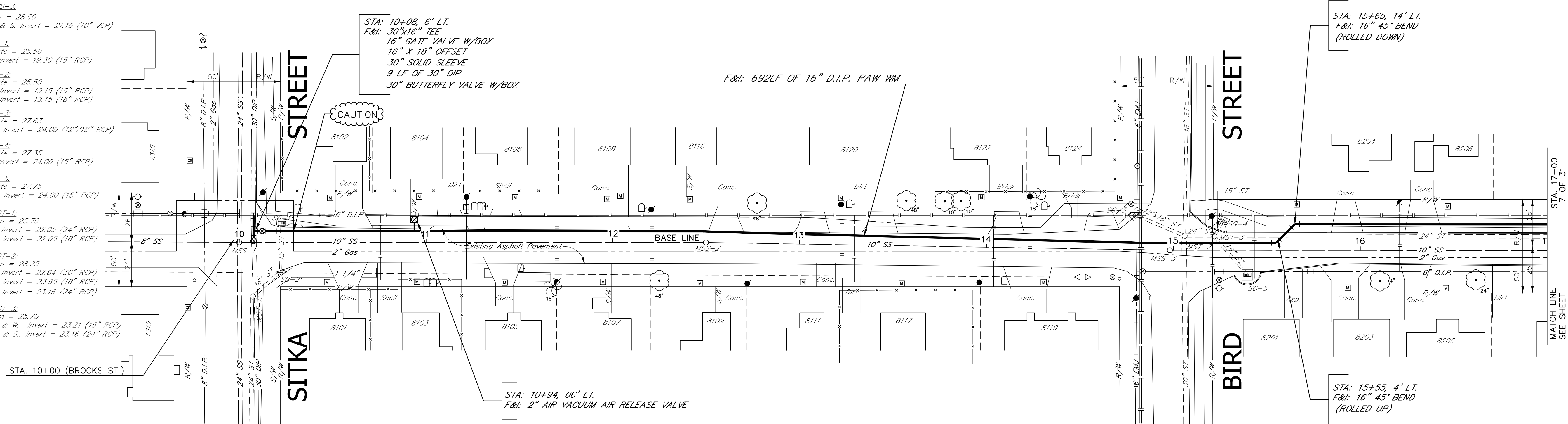

HV-02 0203
Description: C.O.T.S. Alum. Disk
Elevation: 19.608
Location: Mark is located at the southeast corner of Waters Ave. and Nebraska Ave. it is 52' east of the centerline of Nebraska Ave. and 35' south of the centerline of Waters Ave.

- NOTES:
1. POLYWRAP ALL D.I.P. WATER MAIN & APPURTENANCES.
 2. CENTER ONE FULL JOINT OF PIPE UNDER/OVER ALL SANITARY, STORM, OR RECLAIMED WATER CROSSINGS.

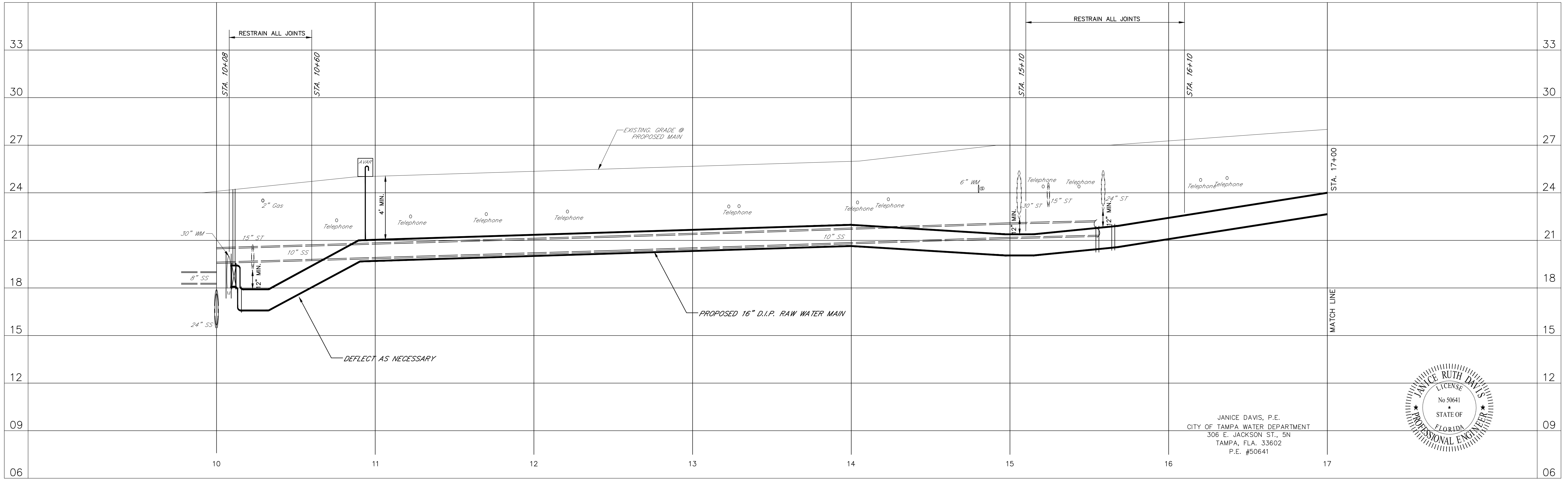

JANICE DAVIS, P.E.
CITY OF TAMPA WATER DEPARTMENT
306 E. JACKSON ST., 5N
TAMPA, FLA. 33602
P.E. #50641

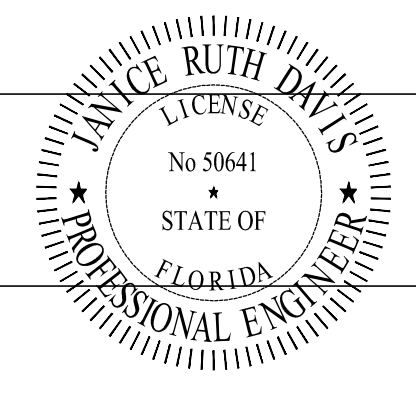

16" RAW WATER MAIN

BROOKS STREET: - from Sitka St. to Busch Blvd.

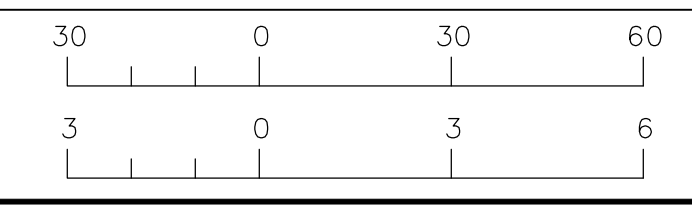

Atlas Page	C13-3				
	D13-4				
No.	1	Date	4/9/15	ADDED S/W, D/W AND PHONE CABLE	PF
By		REVISION			
Approved		Date			

Des:	JRD	W.O.	7410	File:	BLUESINK
Dwn:	PF	FILE NUMBER			
Ckd:	JRD	SHEET	6	OF	31

MSS-4:
Rim = 30.00
N. & S. Invert = 21.81 (10" VCP)

MSS-5:
Rim = 30.00
N. & S. Invert = 22.54 (10" VCP)

MSS-6:
Rim = 31.50
N. & S. Invert = 23.23 (10" VCP)

SG-6:
Grate = 28.18
E. Invert = 25.50 (12"x18" RCP)

SG-2:
Grate = 28.18
W. Invert = 25.50 (12"x18" RCP)

SG-8:
Grate = 28.18
NE. & E. Invert = 25.50 (12"x18" RCP)

SG-9:
Grate = 28.40
W. Invert = 25.75 (12"x18" RCP)

MST-4:
Rim = 29.05
SE, SW, & NW Invert = 25.25 (24" RCP)
W. Invert = 25.25 (24" RCP)
S. Invert = 25.25 (24" RCP)

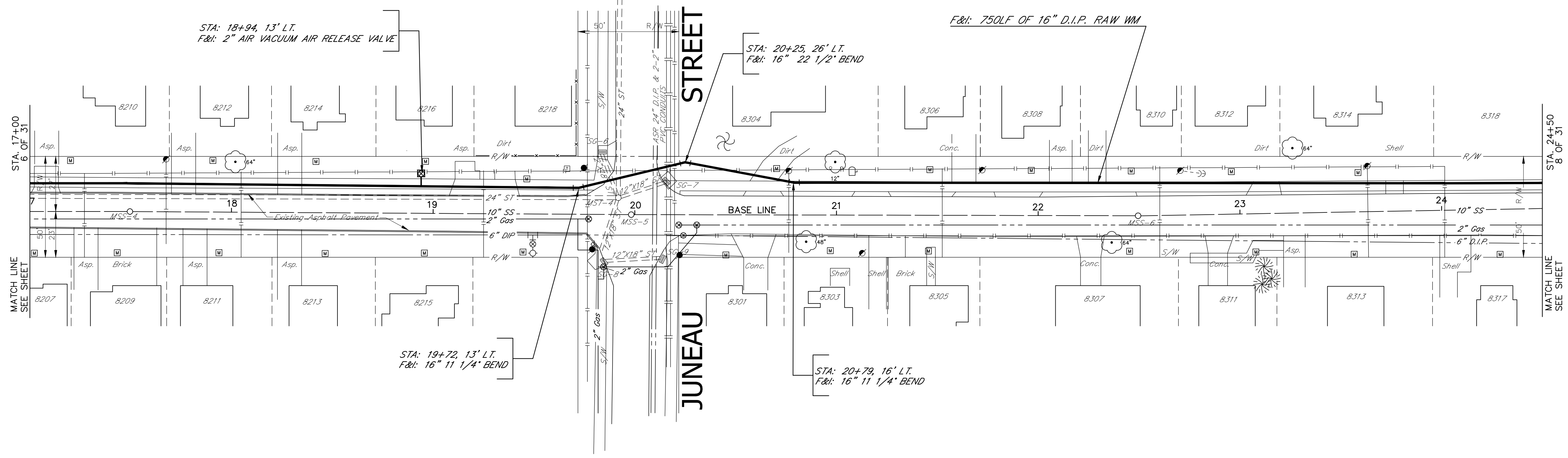

HV-02 0203
Description: C.O.T.S. Alum. Disk
Elevation: 19.608
Location: Mark is located at the southeast corner of Waters Ave. and Nebraska Ave. it is 52' east of the centerline of Nebraska Ave. and 35' south of the centerline of Waters Ave.

NOTES:
1. POLYWRAP ALL D.I.P. WATER MAIN & APPURTENANCES.
2. CENTER ONE FULL JOINT OF PIPE UNDER/OVER ALL SANITARY, STORM, OR RECLAIMED WATER CROSSINGS.

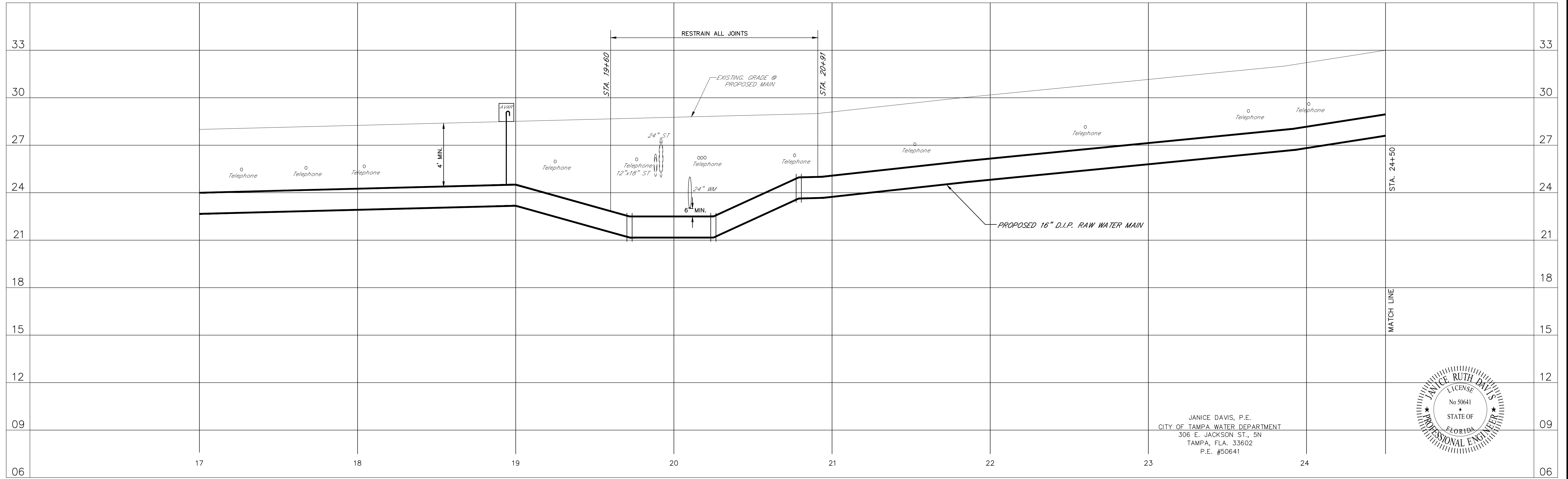

JANICE DAVIS, P.E.
CITY OF TAMPA WATER DEPARTMENT
306 E. JACKSON ST., 5N
TAMPA, FLA. 33602
P.E. #50641

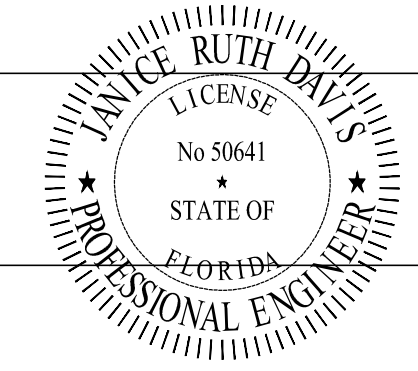

Water Department 16" RAW WATER MAIN BROOKS STREET: - from Sitka St. to Busch Blvd.	30 0 30 60 1" = 30' HORIZ.	3 0 3 6 1" = 3' VERT.	Atlas Page C13-3 D13-4	No. 1 Date 4/9/15 Approved	ADDED S/W, D/W AND PHONE CABLE REVISION Date	Des: JRD Dwn: PF Ckd: JRD	W.O. 7410 FILE NUMBER	File: BLUESINK SHEET 7 OF 31
---	-------------------------------	--------------------------	------------------------------	----------------------------------	--	---------------------------------	--------------------------	---------------------------------

MSS-7:
Rim = 35.00
W. & S. Invert = 23.99 (10" VCP)

MSS-8:
Rim = 35.00
N. & E. Invert = 24.16 (10" VCP)

MSS-9:
Rim = 32.00
N. & S. Invert = 25.02 (10" VCP)

MSS-10:
Rim = 40.20
N. & S. Invert = 25.86 (10" VCP)

SG-10:
Grate = 34.53
N. Invert = 26.00 (18" RCP)
E. Invert = 26.00 (24" RCP)

SG-11:
Grate = 33.50
SW Invert = 30.00 (15" RCP) P.I. STA. 25+59.20

SG-12:
Grate = 33.50
SE Invert = 30.00 (15" RCP)

SG-13:
Grate = 30.80
E. Invert = 28.14 (15" RCP)

SG-14:
Grate = 30.80
W. Invert = 28.14 (15" RCP)

MST-5:
Rim = 33.95
E. Invert = 29.50 (15" RCP)
W. Invert = 29.50 (15" RCP)
N. Invert = 29.50 (18" RCP)
S. Invert = 29.50 (18" RCP)

STA: 24+89, 75' L.T.
F&I: 16" 90° BEND

STA: 25+94, 04' L.T.
F&I: 2" AIR VACUUM AIR RELEASE VALVE

STA: 24+89, 12' L.T.
F&I: 16" 90° BEND

STA: 24+68, 13' L.T.
F&I: 2" AIR VACUUM AIR RELEASE VALVE

HV-02 0203
Description: C.O.T.S. Alum. Disk
Elevation: 19.608
Location: Mark is located at the southeast corner of Waters Ave. and Nebraska Ave. it is 52' east of the centerline of Nebraska Ave. and 35' south of the centerline of Waters Ave.

North
SEC. 19 & 30-T28S-R19E

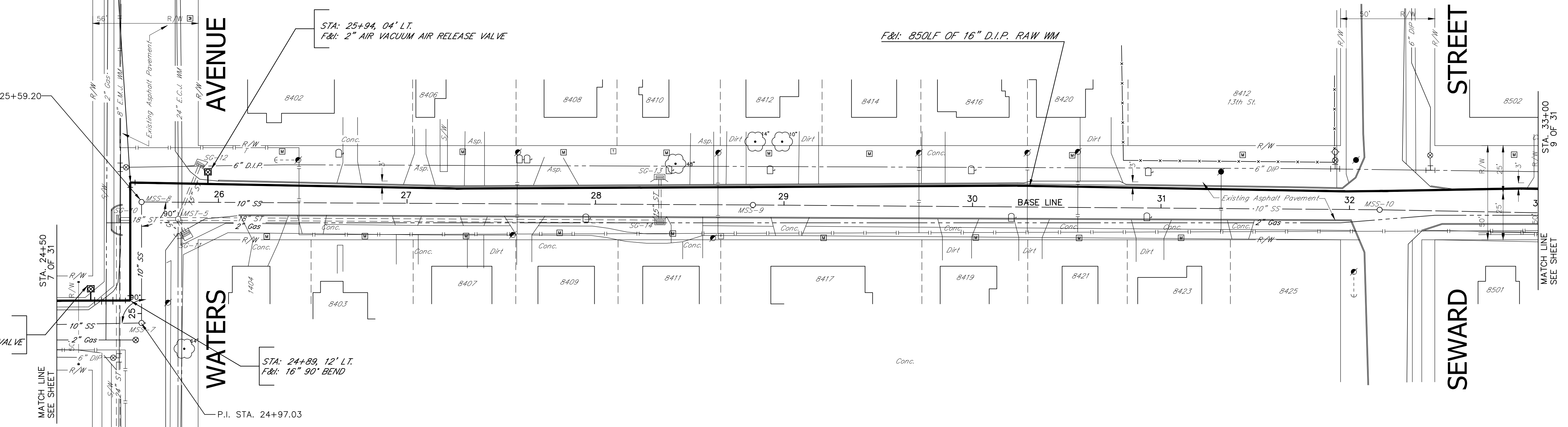

NOTES:
1. POLYWRAP ALL D.I.P. WATER MAIN & APPURTENANCES.
2. CENTER ONE FULL JOINT OF PIPE UNDER/OVER ALL SANITARY, STORM, OR RECLAIMED WATER CROSSINGS.

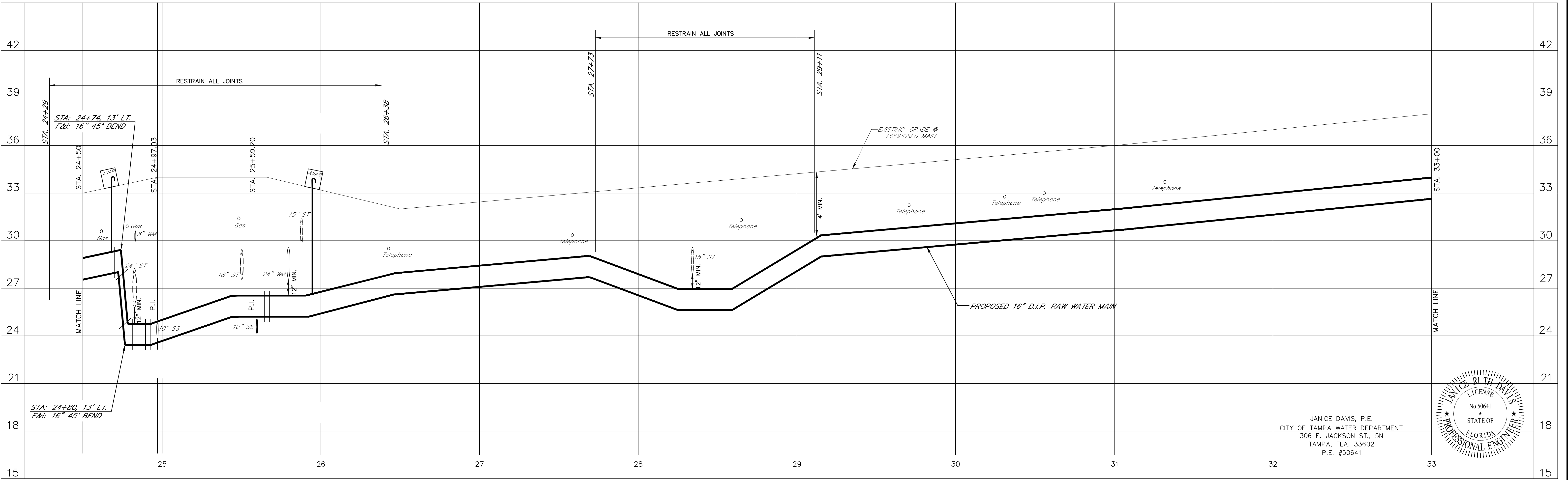

16" RAW WATER MAIN

BROOKS STREET: - from Sitka St. to Busch Blvd.

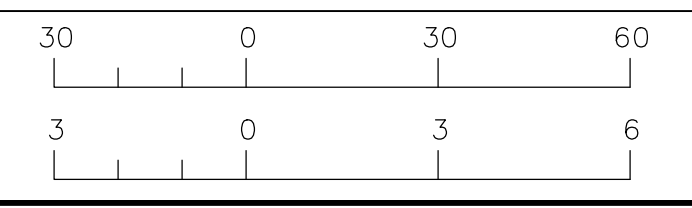

Atlas Page	C13-3
No.	1
Date	4/9/15
By	PF
Approved	REVISION
	Date

Des:	JRD	W.O.	7410	File:	BLUESINK
Dwn:	PF	FILE NUMBER			
Ckd:	JRD	SHEET	8	OF	31

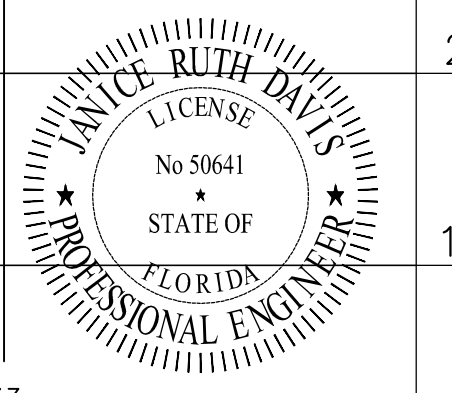

JANICE DAVIS, P.E.
CITY OF TAMPA WATER DEPARTMENT
306 E. JACKSON ST., 5N
TAMPA, FL. 33602
P.E. #50641

MSS-11:
Rim = 37.00
N. & S. Invert = 27.10 (10" VCP)

MSS-12:
Rim = 36.00
S. Invert = 27.89 (10" VCP)
E. & W. Invert = 27.89 (8" VCP)

MSS-13:
Rim = 35.00
N. Invert = 28.41 (8" VCP)
E. & W. Invert = 28.41 (8" VCP)

SG-15:
Grate = 34.44
E. Invert = 31.05 (14" X 23" RCP)
N. Invert = 30.75 (24" RCP)

SG-16:
Grate = 34.44
W. Invert = 31.05 (14" X 23" RCP)

SG-17:
Grate = 34.29
E. Invert = 30.26 (15" RCP)

SG-18:
Grate = 34.95
W. Invert = 29.10 (24" RCP)

SG-19:
Grate = 34.61
S. Invert = 29.94 (15" RCP)

SG-20:
Grate = 33.92
E. Invert = 31.78 (15" RCP)
S. Invert = 31.71 (18" RCP)

SG-21:
Grate = 33.96
W. Invert = 33.92 (15" RCP)

MST-6:
Rim = 35.07
N. & S. Invert = 30.56 (24" RCP)

MST-7:
Rim = 35.09
W. Invert = 29.14 (30" RCP)
E. Invert = 30.15 (18" RCP)
S. Invert = 30.13 (24" RCP)
N. Invert = 29.80 (15" RCP)
SE. Invert = 30.22 (24" RCP)

MST-8:
Rim = 35.30
NW Invert = 30.58 (24" RCP)
SW Invert = 28.03 (24" RCP)
E. Invert = 28.86 (12" RCP)

HV-02 0203
Description: C.O.T.S. Alum. Disk
Elevation: 19.608
Location: Mark is located at the southeast corner of Waters Ave. and Nebraska Ave. it is 52' east of the centerline of Nebraska Ave. and 35' south of the centerline of Waters Ave.

MST-9:
Rim = 34.78
N. Invert = 30.25 (18" RCP)
W. Invert = 29.40 (24" X 38" RCP)
E. Invert = 29.47 (30" RCP)

MST-10:
Rim = 34.58
N. & S. Invert = 30.58 (18" RCP)

BROOKS STREET

STREET

North
SEC. 19 & 30-T28S-R19E

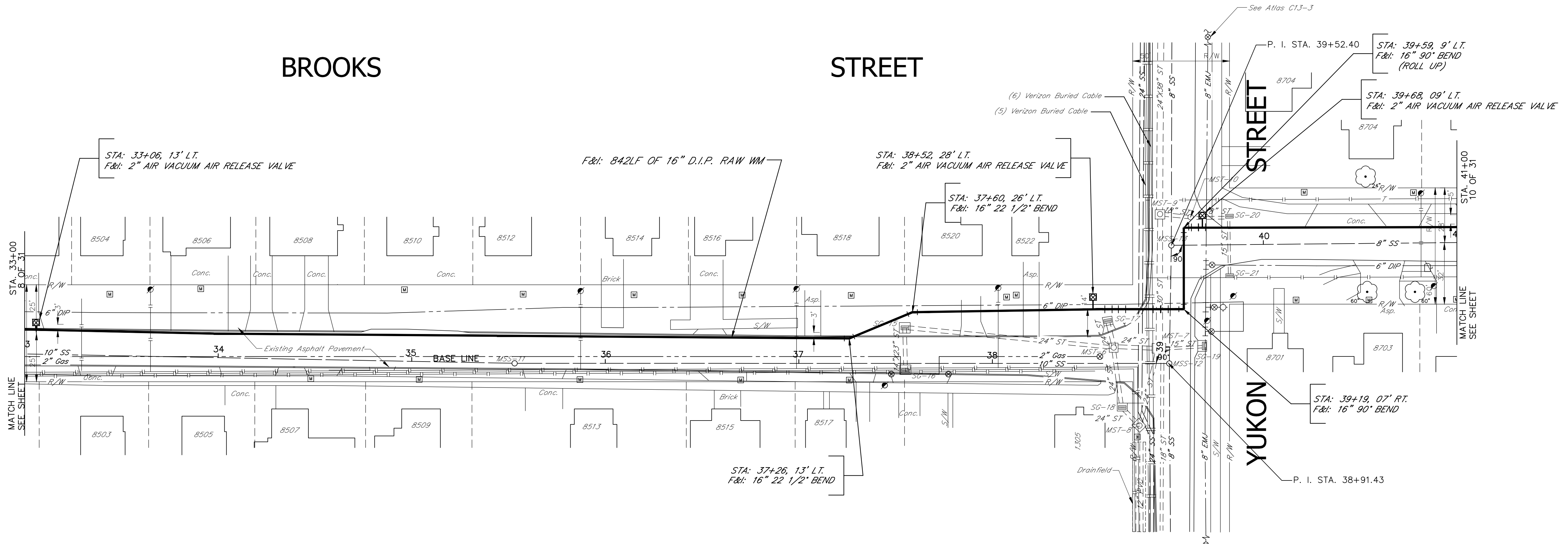

- NOTES:
1. POLYWRAP ALL D.I.P. WATER MAIN & APPURTENANCES.
 2. CENTER ONE FULL JOINT OF PIPE UNDER/OVER ALL SANITARY, STORM, OR RECLAIMED WATER CROSSINGS.

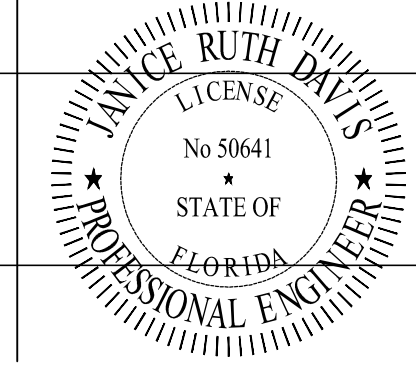
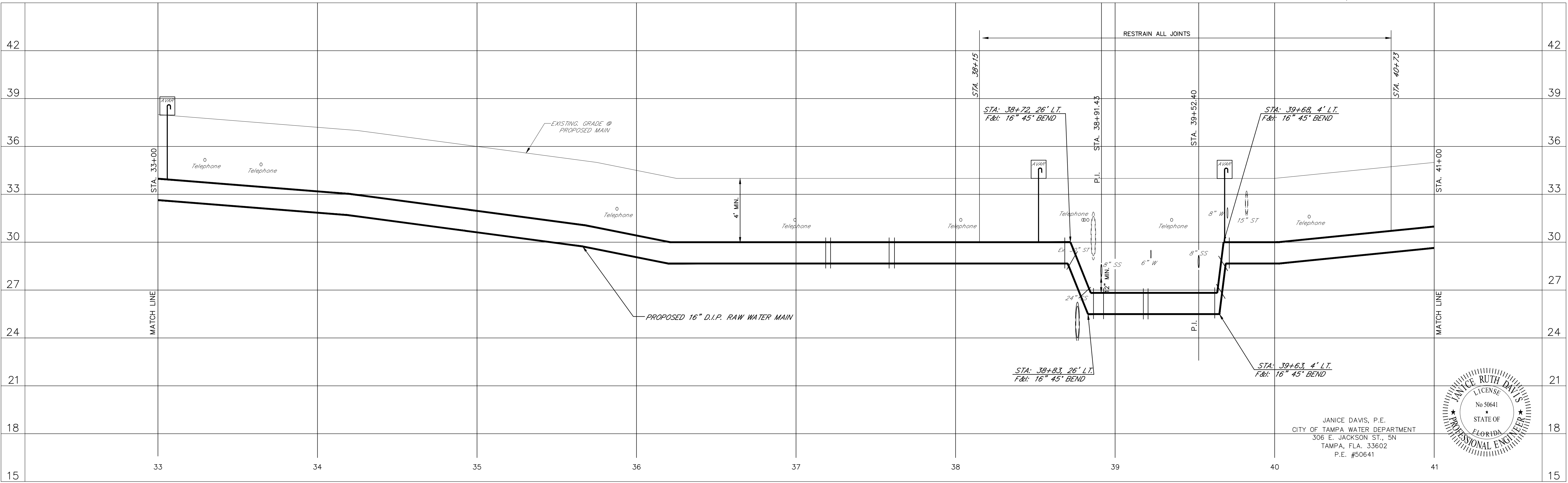

JANICE DAVIS, P.E.
CITY OF TAMPA WATER DEPARTMENT
306 E. JACKSON ST., 5th
TAMPA, FLA. 33602
P.E. #50641



Water Department
16" RAW WATER MAIN

BROOKS STREET: - from Sitka St. to Busch Blvd.

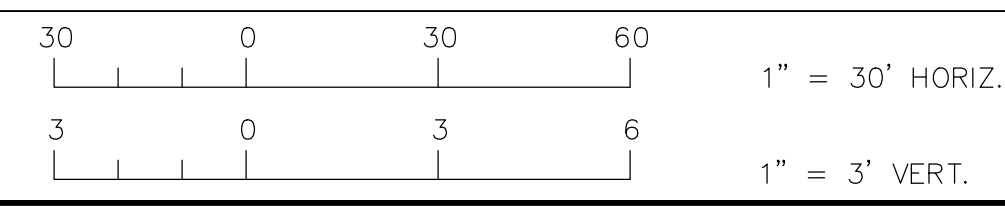

Atlas Page	C13-3
No.	1
Date	4/9/15
By	PF
Approved	REVISION
Date	

Des:	JRD	W.O.:	7410	File:	BLUESINK
Dwn:	PF	FILE NUMBER			
Ckd:	JRD	SHEET	9	OF	31

MSS-14:
Rim = 37.00
N. & S. Invert = 33.92 (8" VCP)

MSS-15:
Rim = 40.00
S. Invert = 36.69 (8" VCP)

SG-22:
Grate = 39.68
NW. Invert = 36.11 (15" RCP)
N. Invert = 30.75 (24" RCP)

SG-23:
Grate = 40.04
SW. Invert = 36.11 (15" RCP)

SG-24:
Grate = 39.58
NE. Invert = 35.07 (15" RCP)
SE. Invert = 35.93 (15" RCP)

SG-25:
Grate = 39.70
SE. Invert = 35.02 (15" RCP)

MST-11:
Rim = 40.03
NW. Invert = 33.31 (15" RCP)
SW. Invert = 33.51 (15" RCP)
NE. Invert = 33.96 (15" RCP)
W. Invert = 38.35 (18" RCP)

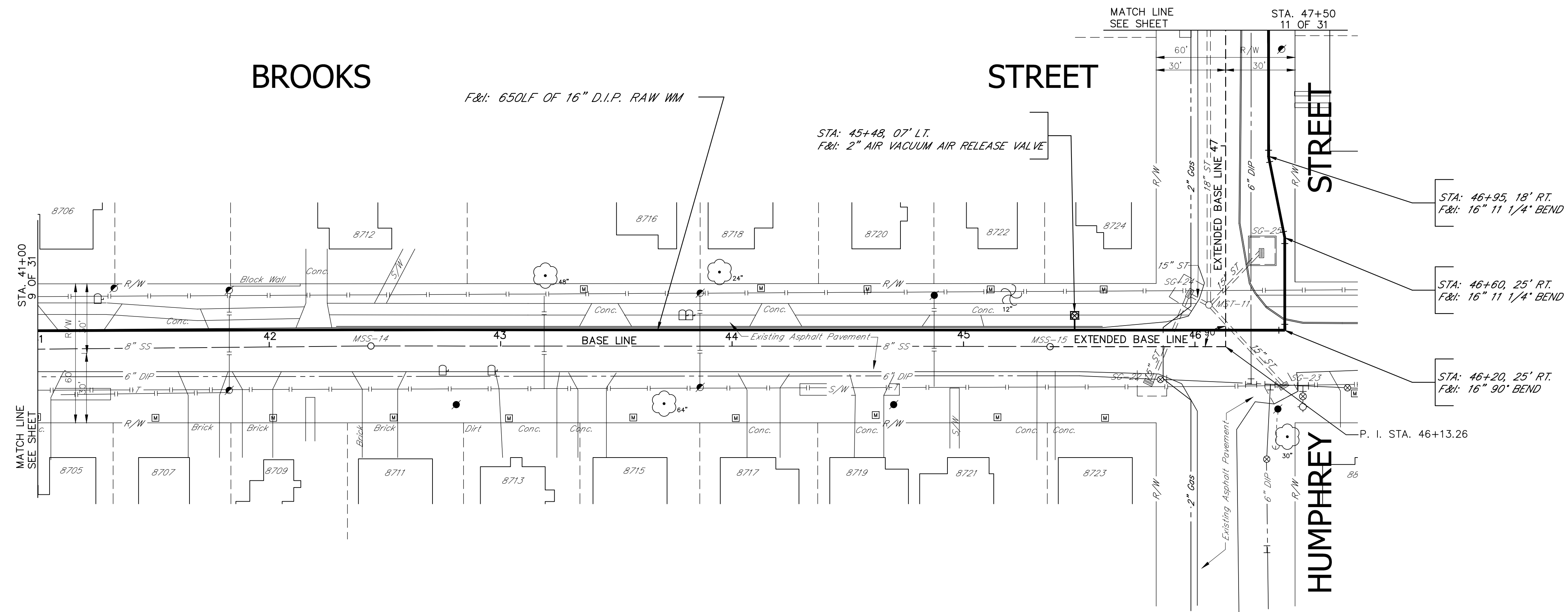

HV-02 0203
Description: C.O.T.S. Alum. Disk
Elevation: 19.608
Location: Mark is located at the southeast corner of Waters Ave. and Nebraska Ave. it is 52' east of the centerline of Nebraska Ave. and 35' south of the centerline of Waters Ave.

- NOTES:
1. POLYWRAP ALL D.I.P. WATER MAIN & APPURTENANCES.
 2. CENTER ONE FULL JOINT OF PIPE UNDER/OVER ALL SANITARY, STORM, OR RECLAIMED WATER CROSSINGS.

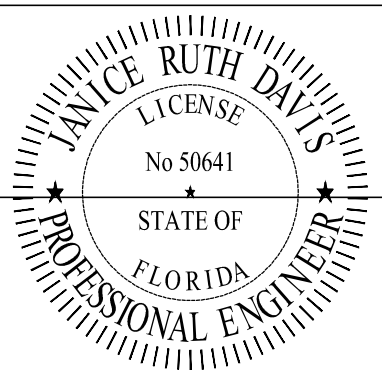
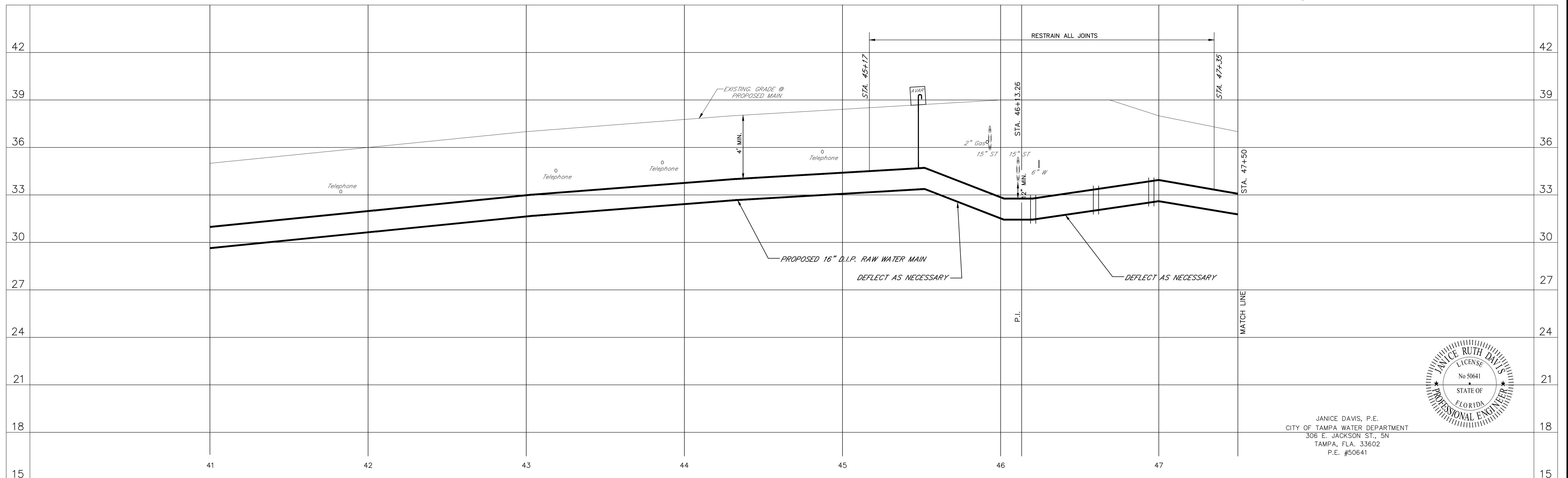

JANICE DAVIS, P.E.
CITY OF TAMPA WATER DEPARTMENT
506 E. JACKSON ST., 5th
TAMPA, FLA. 33602
P.E. #50641



Water Department
16" RAW WATER

BROOKS STREET: - from Sitka St. to Busch Blvd.



Atlas Page	C13-3	Des:	JRD	W.O.	7410	File:	BLUESINK MFL
No.	1	Date	4/9/15	PF		By	PF
By		Date		REVISION		By	JRD
Approved		Date				By	JRD

Des:	JRD	W.O.	7410	File:	BLUESINK MFL
Dwn:	PF	FILE NUMBER			
Ckd:	JRD	SHEET	10	OF	31

MSS-16:
Rim = 37.00
N. & S. Invert = 31.72 (8" VCP)

MSS-17:
Rim = 36.94
N. & S. Invert = 31.90 (8" VCP)
E. Invert = 32.05 (8" DIP)

MSS-18:
Rim = 36.00
N. & S. Invert = 31.24 (24" RCP)
E. & W. Invert = 32.05 (8" DIP)

MSS-19:
Rim = 37.20
N. Invert = 32.08 (8" VCP)
W. Invert = 32.05 (8" DIP)

MSS-20:
Rim = 37.00
N. & S. Invert = 32.45 (8" VCP)

MSS-21:
Rim = 36.50
S. Invert = 33.40 (8" DIP)

MSS-22:
Rim = 37.00
S. Invert = 33.24 (8" VCP)

SC-26:
Grate = 36.40
NE. Invert = 32.98 (15" RCP)

SC-27:
Grate = 35.79
N. Invert = 31.00 (12" X 18" RCP)

SC-28:
Grate = 35.85
SE. Invert = 33.10 (15" RCP)

SC-29:
Grate = 36.40
SW. Invert = 32.40 (15" RCP)

SC-30:
Grate = 36.07
E. Invert = 33.89 (12" X 18" RCP)

SC-31:
Grate = 36.26
W. Invert = 33.04 (15" RCP)

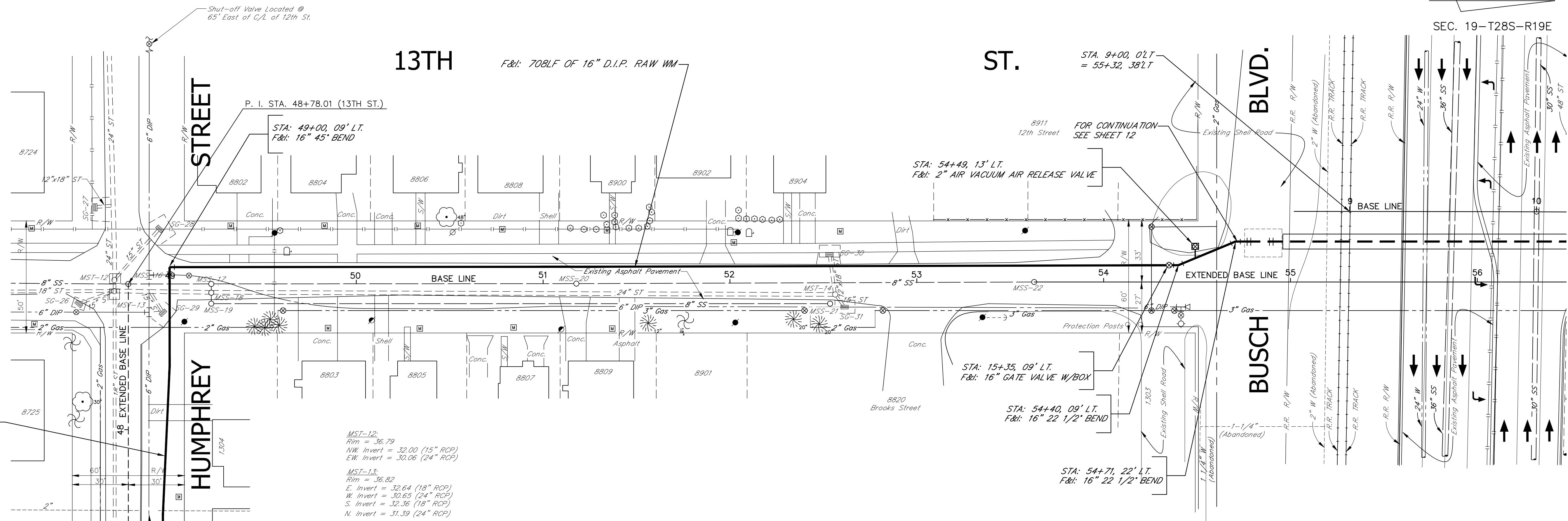

HV-02 0203
Description: C.O.T.S. Alum. Disk
Elevation: 19.608
Location: Mark is located at the southeast corner of Waters Ave. and Nebraska Ave. it is 52' east of the centerline of Nebraska Ave. and 35' south of the centerline of Waters Ave.

MST-12:
Rim = 36.79
NW. Invert = 32.00 (15" RCP)
EW. Invert = 30.06 (24" RCP)

MST-13:
Rim = 36.82
E. Invert = 32.64 (18" RCP)
W. Invert = 30.65 (24" RCP)
S. Invert = 32.36 (18" RCP)
N. Invert = 31.39 (24" RCP)

MST-14:
Rim = 36.48
W. Invert = 33.24 (12" X 18" RCP)
S. Invert = 31.94 (24" RCP)
E. Invert = 32.81 (15" RCP)

NOTES:
1. POLYWRAP ALL D.I.P. WATER MAIN & APPURTENANCES.
2. CENTER ONE FULL JOINT OF PIPE UNDER/OVER ALL SANITARY, STORM, OR RECLAIMED WATER CROSSINGS.

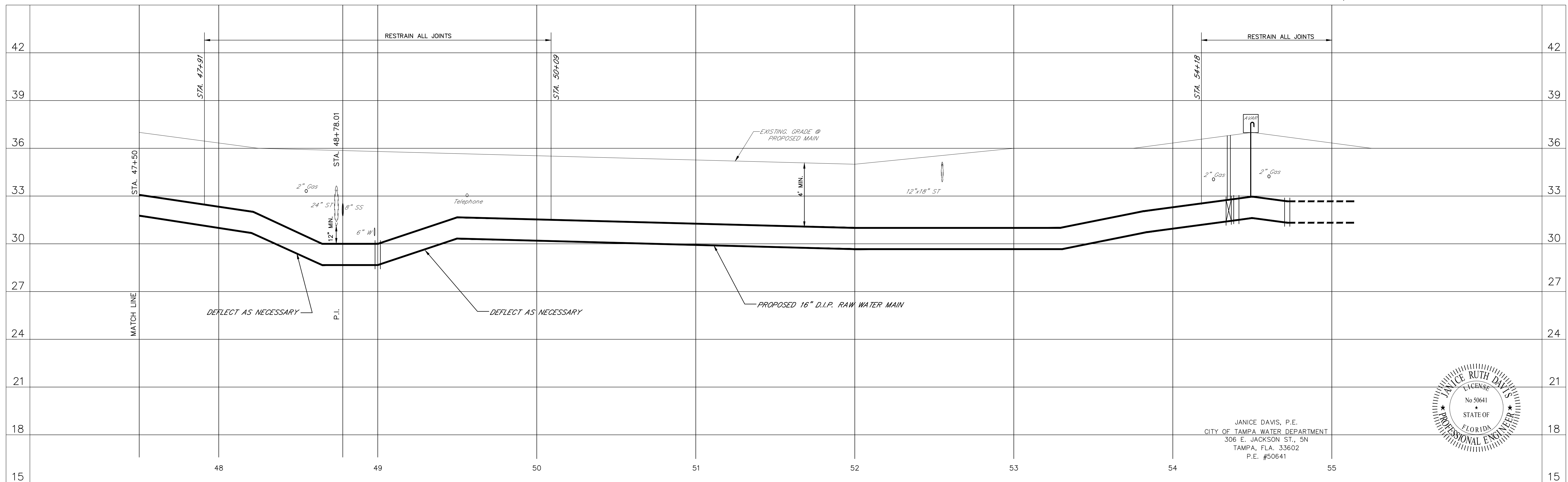

JANICE DAVIS, P.E.
CITY OF TAMPA WATER DEPARTMENT
306 E. JACKSON ST., 5N
TAMPA, FLA. 33602
P.E. #50641

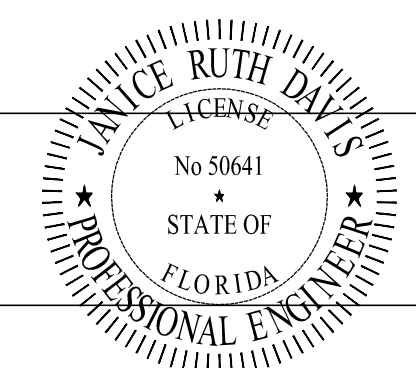

16" RAW WATER MAIN

BROOKS STREET: - from Sitka St. to Busch Blvd.

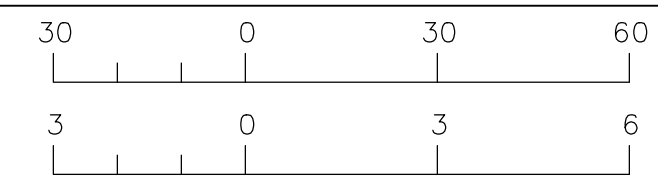

1" = 30' HORIZ.
1" = 3' VERT.

Atlas Page
C13-3
D13-4

No.	Date	REVISION	By
1	4/9/15	ADDED PHONE CABLE	PF

Des: JRD
Dwn: PF
Ckd: JRD

W.O. 7410
FILE NUMBER

File: BLUESINK

SHEET 11 OF 31

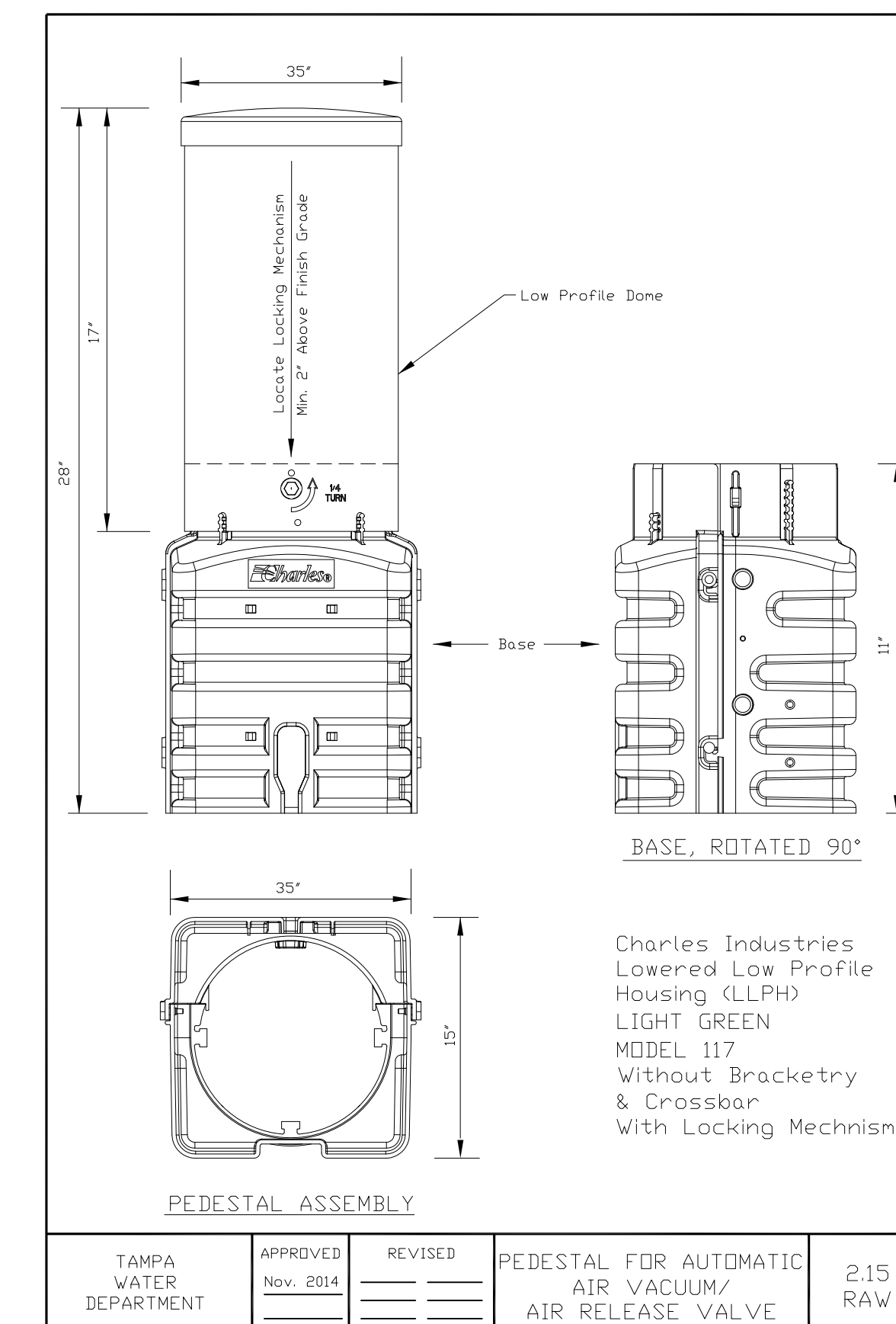
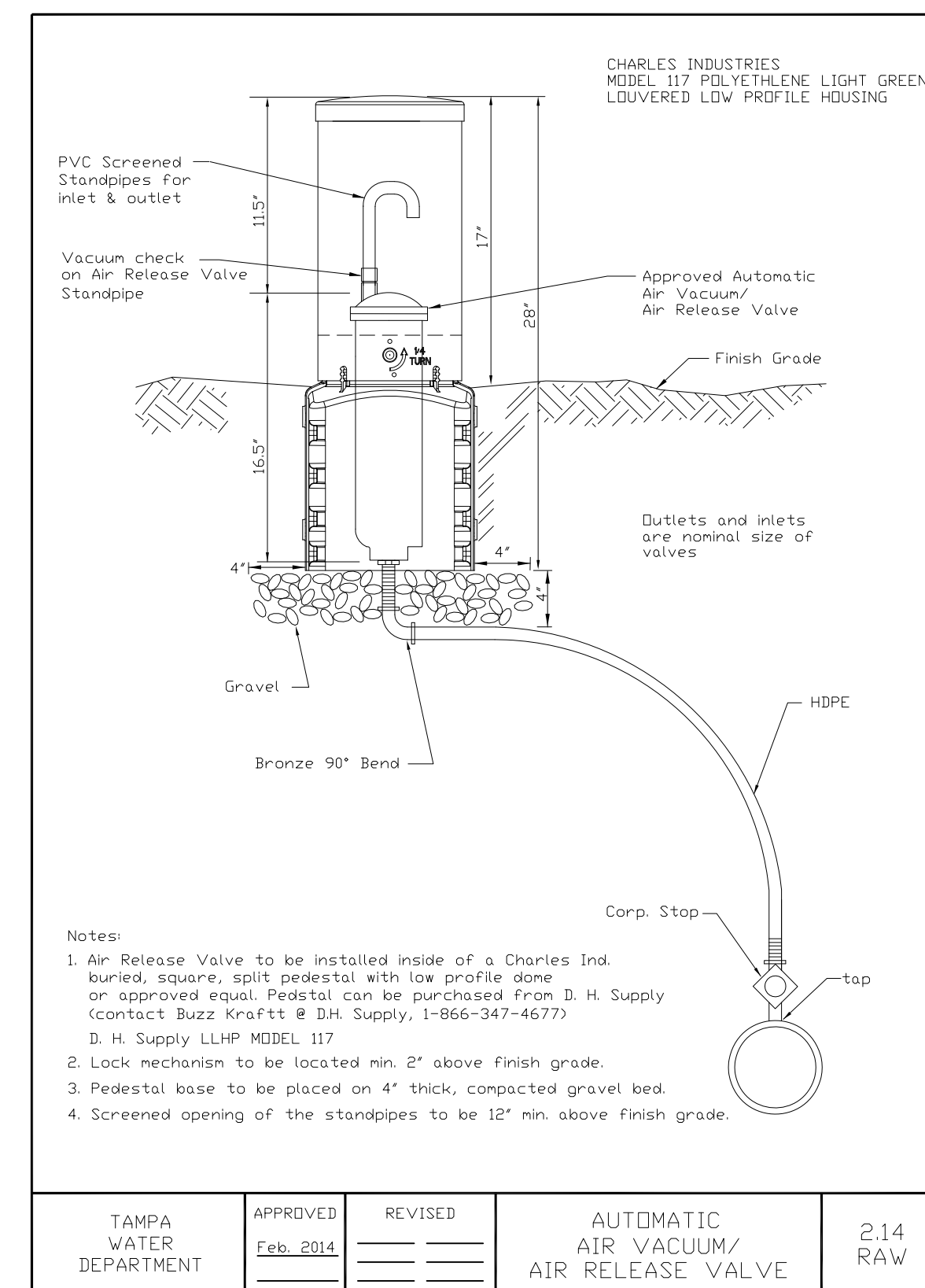
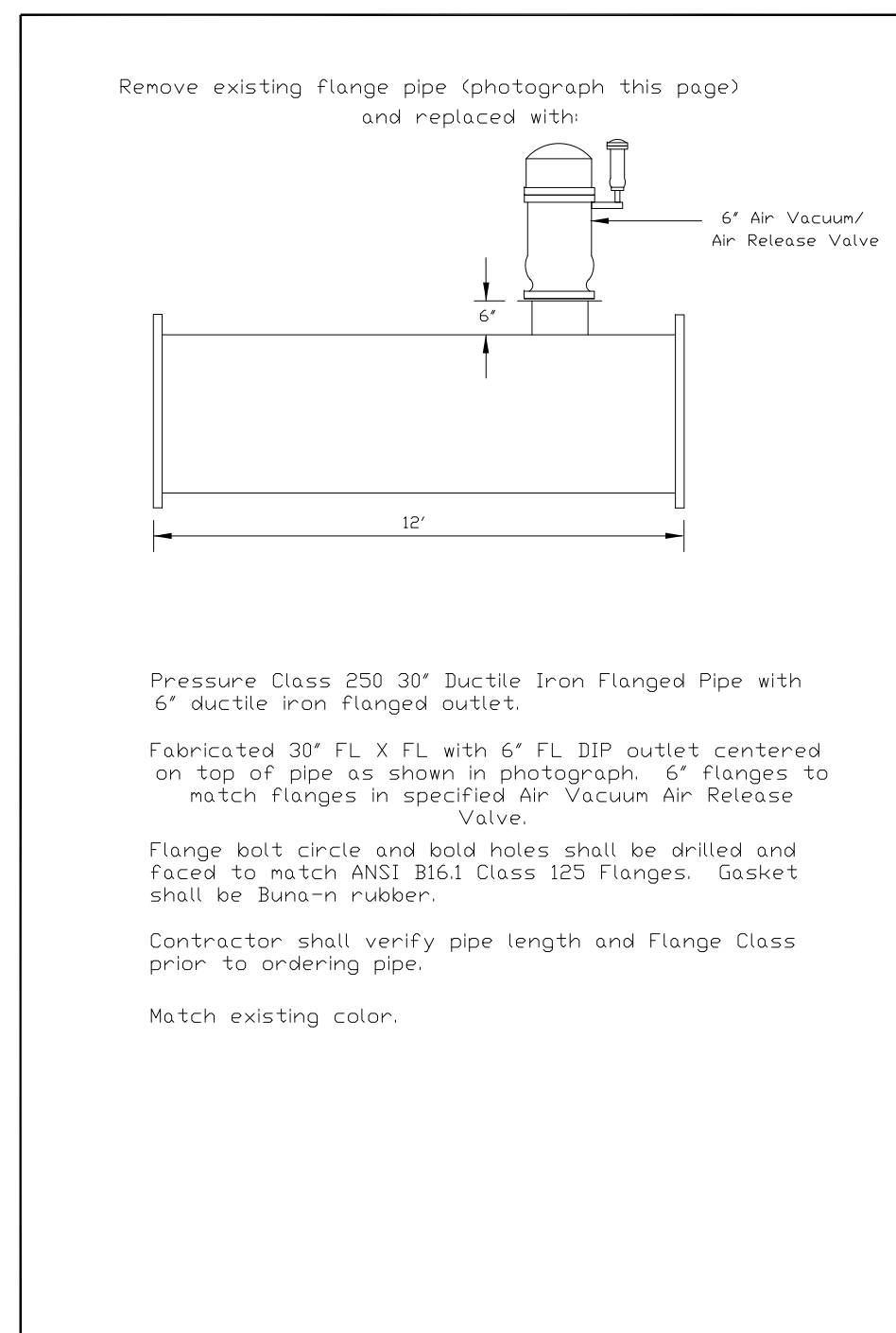
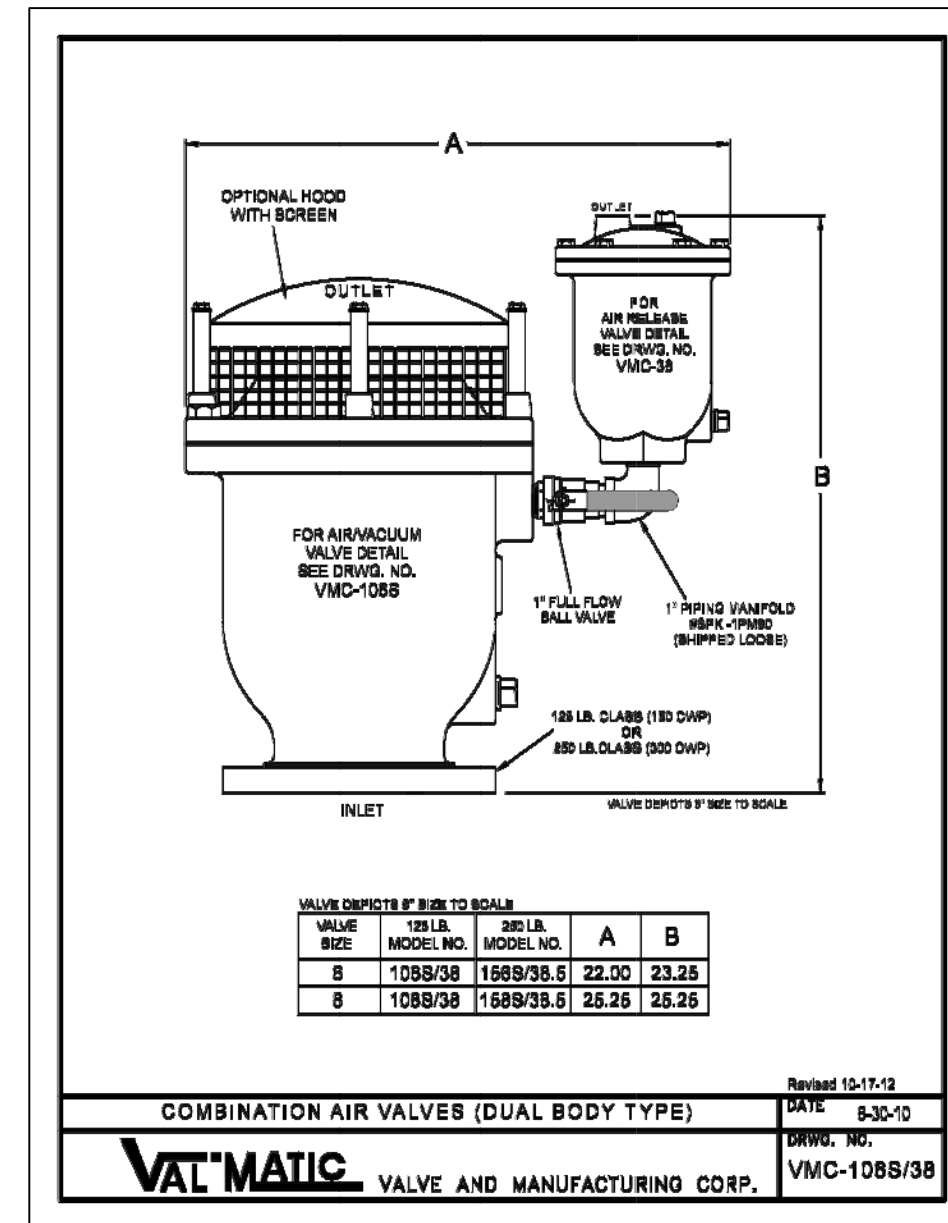

Table 1: Modeled AVAR Summary

Model Junction / Elevation (ft)	AVAR Size (in)	Location
(1) 118 / 33 ¹	3	Blue Sink Pump Station Discharge Header TWO REQUIRED
152 / 33 ¹	2	Downstream of Blue Sink Pump Station at the upstream high point of the Wetland Crossing ADDED TO PIPELINE PLANS
128 / 24.2 ¹	2	3,000 ft from Blue Sink Pump Station (Not required for surge mitigation)
158 / 26.5 ¹	2	4,000 ft from Blue Sink Pump Station
19 / 28.5 ¹	2	E. Bougainville, East of Arden, 8,000 ft from Blue Sink Pump Station
21 / 26.5 ¹	2	E. Bougainville and Jasmine Ave, 8,850 ft from Blue Sink Pump Station
23 / 23.5 ¹	2	Jasmine Ave and Linebaugh Avenue, 10,000 ft from Blue Sink Pump Station
28 / 31.5 ¹	2	N. 12 th St., South of Lotus Street, 11,500 ft from Blue Sink Pump Station
170 / 33.5 ¹	2	Wilma St. and N 12 th St., 12,900 ft from Blue Sink Pump Station
35 / 32.0 ¹	2	13 th St. and Bush Blvd., 13,900 ft from Blue Sink Pump Station
38 / 34.0 ¹	2	Humphrey and Brooks St., 14,850 ft from Blue Sink Pump Station
42 / 32.5 ¹	2	Brooks St. and Seward St., 16,000 ft from Blue Sink Pump Station
174 / 28.5 ¹	2	Brooks St., South of Waters Ave., 16,900 ft from Blue Sink Pump Station
(2) 22 / 18.1 ²	6	Sulphur Springs Pump Station Discharge Header 8" REQ. INSIDE PUMP STA
48 / 17 ²	2	Sitka St and Alaska St. (existing Air Valve)
50 / 20 ²	2	Sitka St and N Mulberry St. (existing Air Valve)
(3) 51 / 20 ²	2	Sitka St and Semmes St., 3,100 ft from Sulphur Springs Pump Station F&I
(4) 52 / 21 ²	2	Sitka St and Elmer St., 3,600 ft from Sulphur Springs Pump Station F&I
(5) 58 / 12 ²	2	5,800 ft from Sulphur Springs Pump Station F&I
(6) 60 / 11 ²	2	6,850 ft from Sulphur Springs Pump Station F&I

¹ Blue Sink Pipeline; ² Sulphur Springs Pipeline; ³ Sulphur Springs Pipeline

NOTE:

- In Table 1: Modeled AVAR Summary above, six air vacuum air release valves are not shown in the project drawings.
- Valve 1 is to be placed on the 16" discharge header pipe at the highest point at the blue sink pump station.
- Valve 2 is to be placed on the 30" discharge header pipe at the highest point at the Sulphur Springs pump station on Nebraska Avenue. Details are provided on this sheet.
- Valves 3 through 6 are to be placed at various distances from the Sulphur Springs pump station along Sitka Avenue. These valves shall be tapped as shown in standard details 2.14 and 2.15 on this sheet. Pay Items for performing operations are detailed in the Contract Pay Items.
- Cutting pavement and restoration of pavement will be required. For estimating purposes, assume a trench width of 5' x 10' with 20' of 2" HDPE tubing.

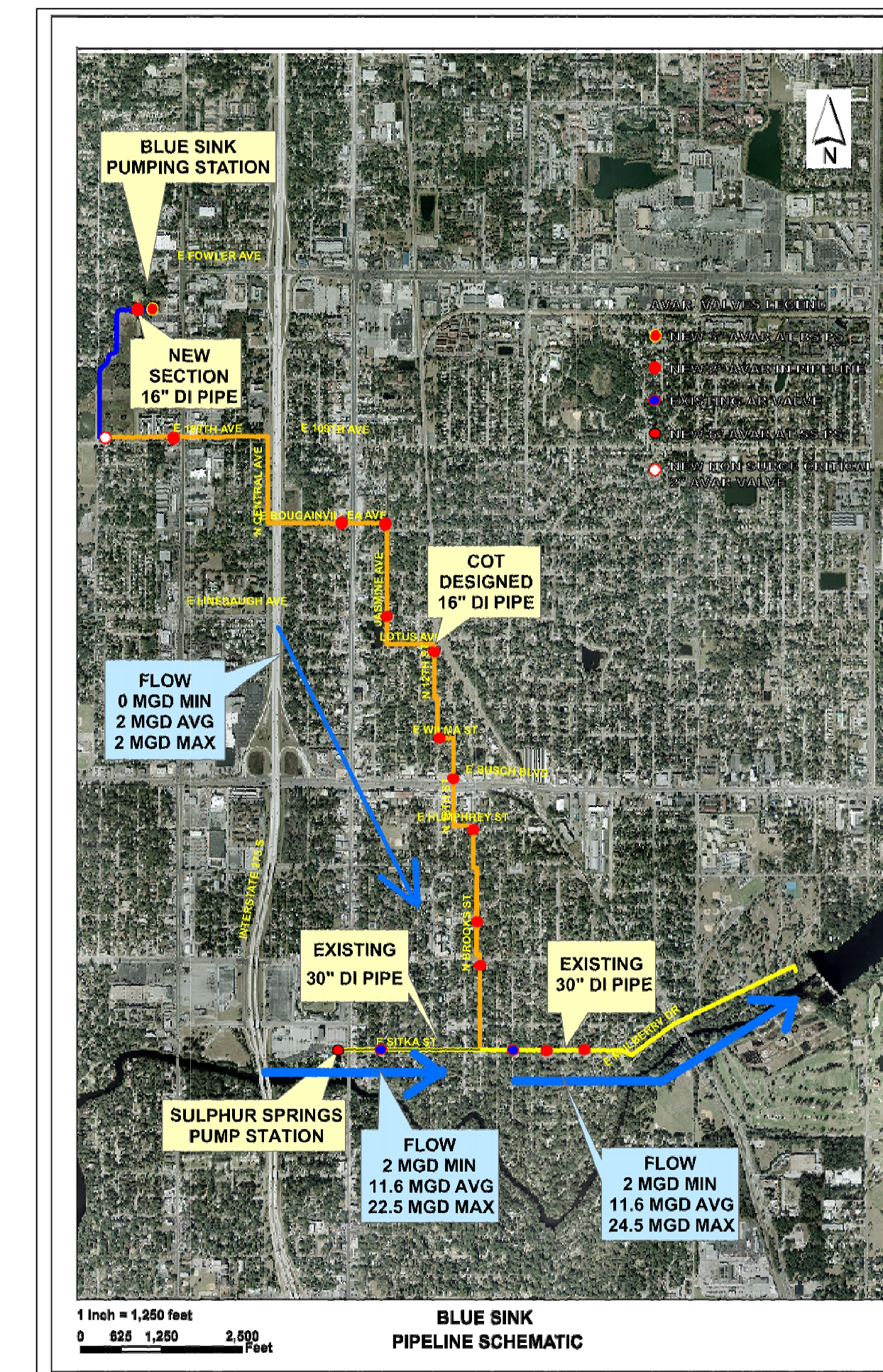

JANICE DAVIS, P.E.
CITY OF TAMPA WATER DEPT.
306 E. JACKSON ST., 5E
TAMPA, FLA. 33602
P.E. #50641

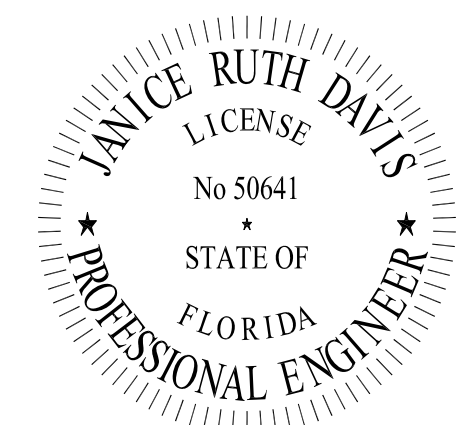

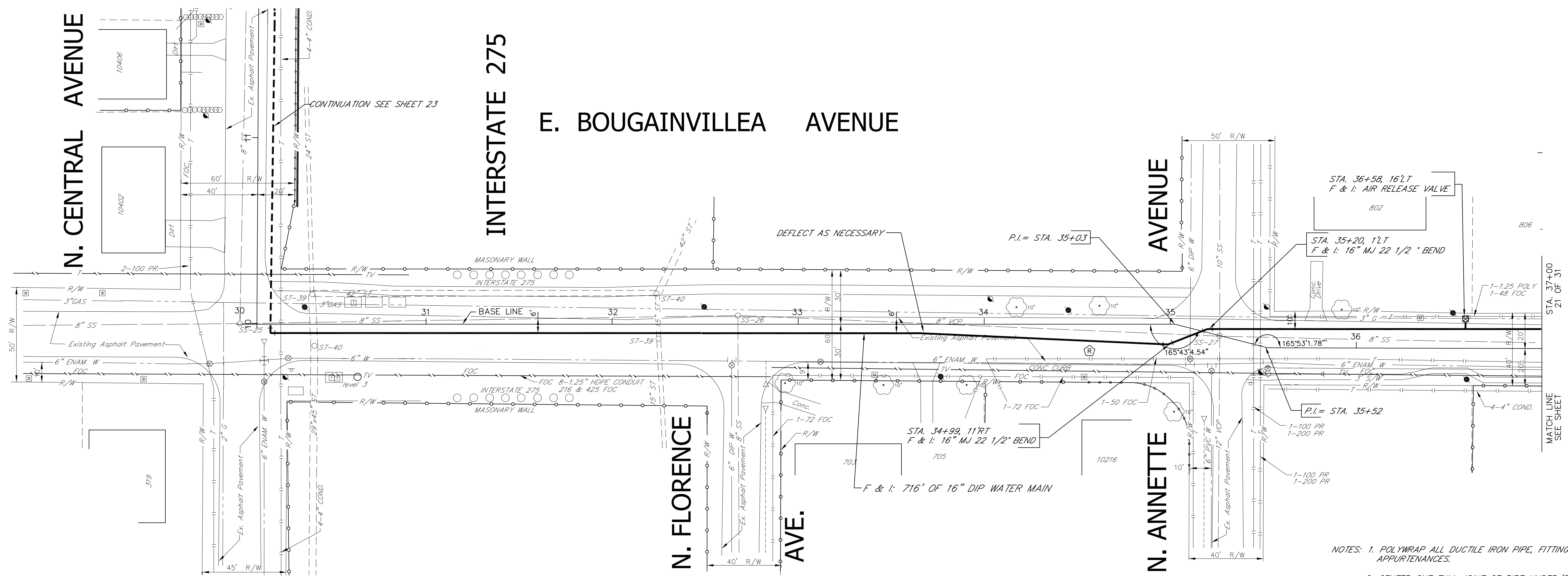

Sec. 13-T28S-R18E

- SAN. SEWER
SS-25
INV. 25.50 (8" SS)
- SAN. SEWER
SS-26
INV. 23.14 (8" SS)
- SAN. SEWER
SS-27
N. INV. 22.15 (10" SS)
E & W INV. 22.27 (8" SS)
- STORM WATER
ST-38
N. INV. 22.7 (29"x45" RCP)
- STORM WATER
ST-39
INV. 25.5 (15" RCP)

NOTES: 1. POLYWRAP ALL DUCTILE IRON PIPE, FITTINGS AND APPURTENANCES.
2. CENTER ONE FULL JOINT OF PIPE UNDER/OVER ALL WATER MAIN CROSSINGS.

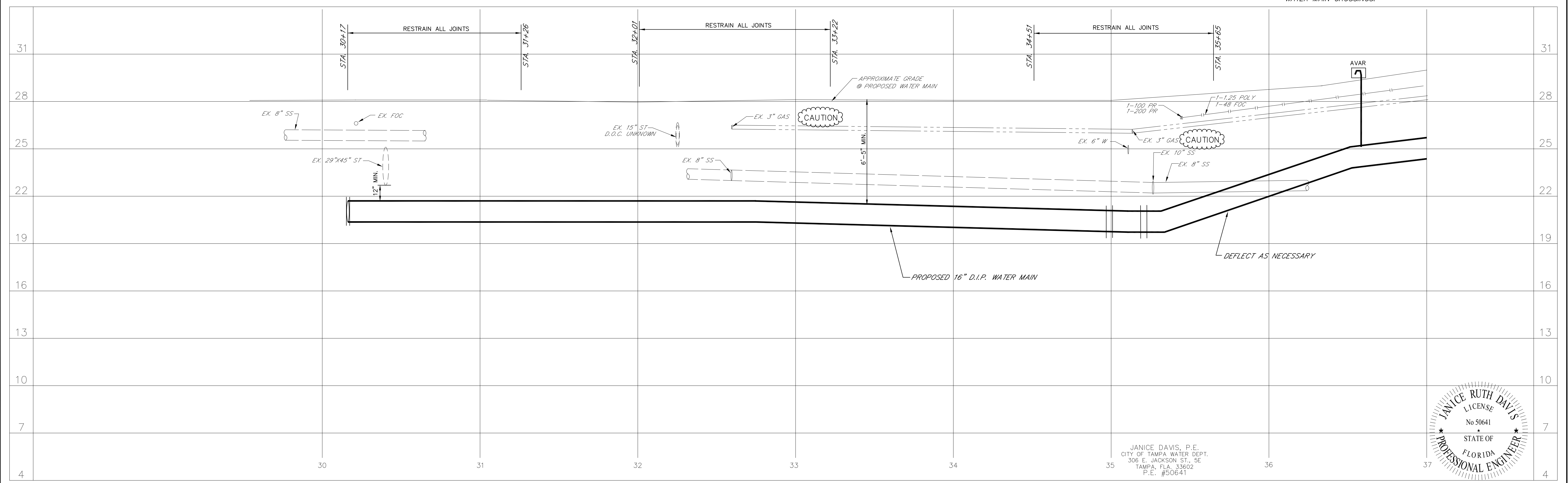

JANICE DAVIS, P.E.
CITY OF TAMPA WATER DEPT.
306 E. JACKSON ST., 5E
TAMPA, FLA. 33602
P.E. #50641

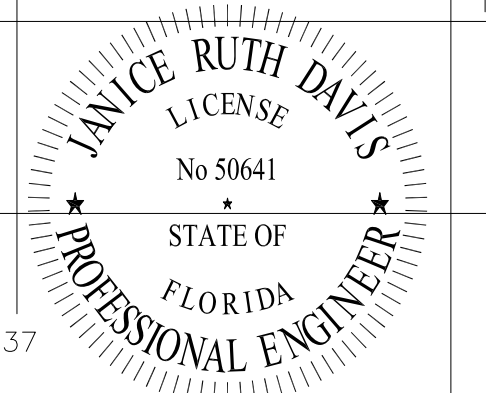

WATER DEPARTMENT
16" RAW WATER MAIN

BOUGAINVILLEA AVE- from:
N. Central Ave to Sta. 37+00

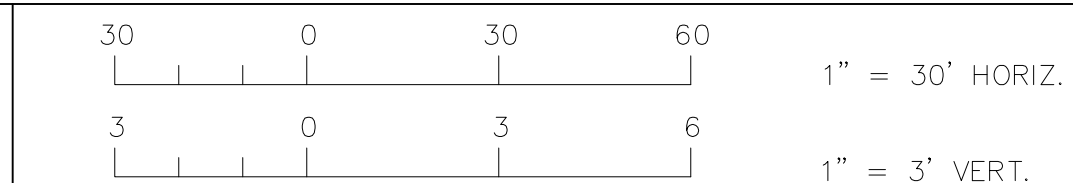

Atlas Page	No. 1	Date	3/24/15	REVISION	ALIGNMENT	By	JDM
	B12-2						
Approved		Date					

Des:	JH	W.O. 7410	File: BLUE SINK
Dwn:	JDM	FILE NUMBER	
Ckd:	JRD	SHEET 20	OF 31

NORTH
 SEC. 19 & 30-T28S-R19E

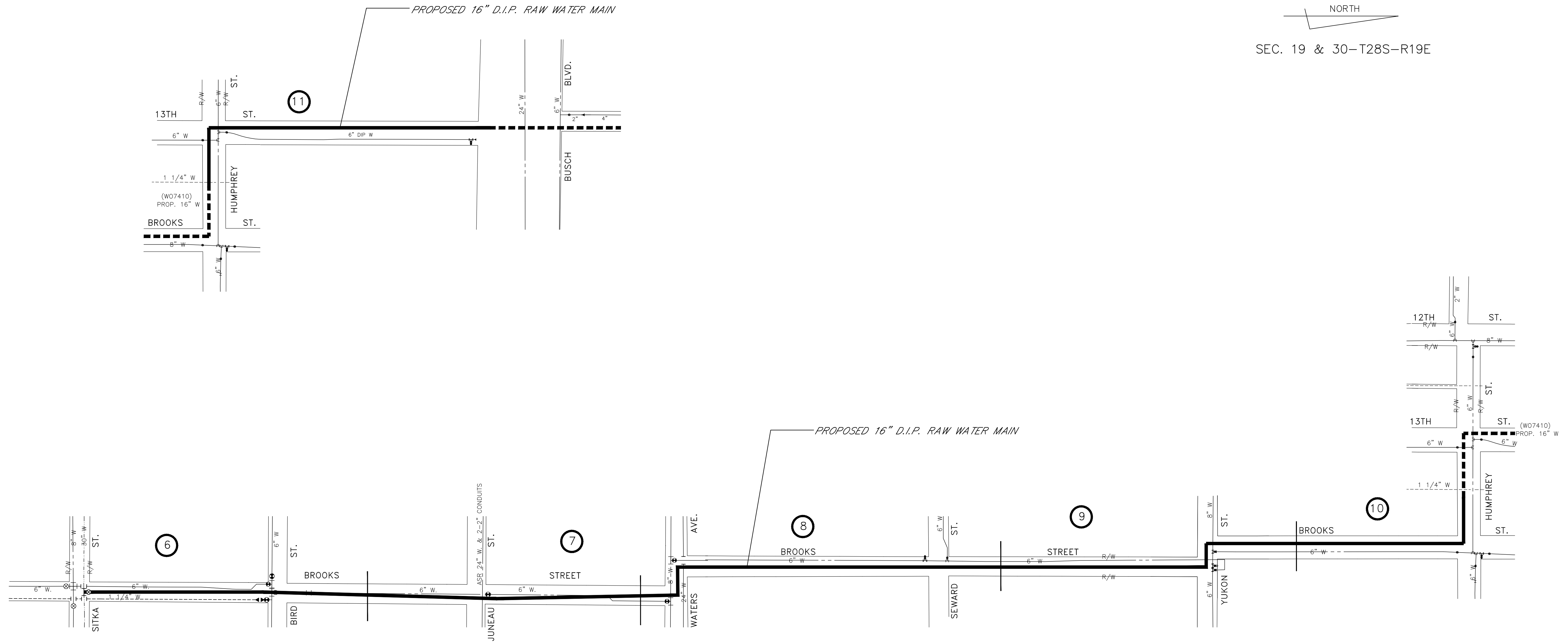

JANICE DAVIS, P.E.
 CITY OF TAMPA WATER DEPARTMENT
 306 E. JACKSON ST., 5N
 TAMPA, FLA. 33602
 P.E. #50641

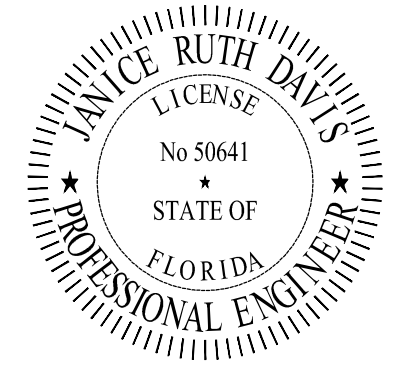

16" RAW WATER MAIN

KEY SHEET

NOT TO SCALE

Atlas Page	1	4/9/15	ADDED S/W, D/W AND PHONE CABLE	PF	Des:	JRD	W.O. 7410	FILE: BLUE SINK
C13-3	No.	Date	REVISION	By	Dwn:	PF	FILE NUMBER	
D13-4	Approved	Date			Ckd:	JRD	SHEET 2	OF 31

CONTRACT PAY ITEMS

C1.00 GENERAL

The Contractor shall receive and accept the compensation provided in the Proposal and the Contract as full payment for furnishing all materials and all labor, tools and equipment, for performing all operations necessary to complete the work under the Agreement, and also in full payment for all loss or damages arising from the nature of the work, or from any discrepancy between the actual quantities of work and quantities herein estimated by the City of Tampa Water Department Engineer, or from the action of the elements or from any unforeseen difficulties which may be encountered during the prosecution of the work until the final acceptance by the City of Tampa Water Department.

It is the intent of these contract documents that any cost for which compensation is not directly provided by a bid item shall be prorated and included in the bid item for which they are required.

The prices stated in the Proposal include all costs and expenses for taxes, labor, equipment, commissions, transportation charges and expenses, patent fees and royalties, labor for handling material during inspection together with any and all other costs and expenses for performing and completing the work as shown on the plans and specified herein. The basis of payment for any item at the unit price shown in the Proposal shall be in accordance with the description of that item in this Section.

No separate payment will be made for the following items and the cost of such work shall be included in the applicable contract pay items of work, including any charges for any mobilization/demobilization that may be required for compliance with FDEP or any other regulatory agency:

1. Clearing and grubbing.
2. Excavation, including necessary pavement/slab removal.
3. Shoring and sheeting as required by OSHA trench excavation safety standards.
4. Dewatering and disposal of surplus water.
5. Backfill and proper compaction, including suitable fill.
6. Grading.
7. Replacement or restoration of paved or unpaved roadways, grass and shrubbery plots outside of established pay limits.
8. Temporary facilities and controls during construction such as water/sanitary facilities, traffic control, informational signs and environmental protection, unless specifically provided for in a pay item.
9. Removing and disposing of waste material due to construction.
10. Cleanup.
11. Refill materials, including suitable fill except as hereinafter specified.
12. Testing and placing system in operation, including re mobilization for any failed testing.
13. Any material and equipment required to be furnished and installed and used for the tests.
14. Maintaining the existing quality of water service during construction.
15. Repair of sanitary sewer house laterals and water services damaged during construction.
16. Appurtenant work as required for a complete and operable system.
17. Coordination with all Federal, State and Local agencies and utilities.
18. Cleaning and flushing the new raw water main.

19. Tree trimming as required by the City of Tampa Parks Department (or any other agency).
20. Verification of pipe elevation.
21. Maintaining red line drawings during construction and furnishing AutoCAD and PDF As-Built drawings.

The Contractor's attention is again called to the fact that the quotations for the various items of work are intended to establish a total price for completing the work in its entirety. Should the Contractor feel that the cost for any item of work has not been established by the Contract's Contract Pay Items, s/he shall include the cost for that work in some other applicable bid item, so that his proposal for the project does reflect his total price for completing the work in its entirety.

The quantities for payment under this Agreement shall be determined by actual measurement of the completed items, in place, ready for service and accepted by the City, in accordance with the applicable method of measurement therefore contained herein. A representative of the City shall witness all field measurements.

All work shall be in accordance with the Technical Specifications and Standard Details herein. All materials shall be in accordance with the Material Specifications herein.

C2.00 PIPELINE INSTALLATION

C2.10 Ductile Iron

The Contractor shall provide all labor, equipment, and materials to furnish and/or install the ductile iron pipe. The installation of the ductile iron pipe shall include, but may not be limited to:

1. Excavating the trench;
2. Maintaining the trench which shall include dewatering and sheeting and bracing as required by OSHA or as directed by the City of Tampa Water Department Engineer;
3. Cleaning dirt and foreign material from within pipe and bell;
4. Beveling field-cut joints and pipe shorts;
5. Furnishing and installing City of Tampa Water Department approved pipe and any pipe shorts as part of the pipeline;
6. Furnishing and installing City of Tampa Water Department approved pipe in casing pipe when shown on the plans;
7. Backfilling and compacting the trench including regrading the terrain;
8. Cleaning up and removing excess water main pipe and appurtenances;
9. Pressure/leak testing the new water main pipe;
10. Furnishing and installing clary sage green polyethylene encasement;
11. Furnishing gasket-type "Gripper" restraint devices for restraint of new push-on joint DI Pipe as shown on the plans or as directed by the Engineer;
12. Remove and dispose of existing 12' length of water main at Sulphur springs pump station;
13. Furnish and install fabricated 12' length of 30" ductile iron flanged pipe with 6" flanged outlet. The Contractor shall verify length and flange class of existing pipe;
14. Furnish and apply paint for above ground pipe. Paint to be high-grade enamel, green to match existing paint, or as directed by the Engineer, with the technical assistance of the City of Tampa Water Department Engineer;
15. Cleaning up and restoring the job site which shall include re-grading the terrain; and
16. Removing and legally disposing all waste materials.

Payment for connecting new raw water mains to existing raw water mains will be made utilizing the contract unit price for furnishing and installing the fittings or valves used in the connection.

The cost to hydrostatically test the ductile iron water mains shall be prorated and included in the pipeline construction unit prices. The prorated cost should include, but may not be limited to furnishing and installing all:

- 1) Material
- 2) Labor
- 3) Necessary pumps
- 4) Recorder charts
- 5) Gages (300 PSIG limit, oil-filled)
- 7) Temporary valves
- 8) Temporary plugs
- 9) Sample Taps, (including installation of brass dry-main plugs after sample tap removal)
- 10) Blow off assemblies (including removal after testing is complete)
- 11) Dry main plugs

necessary to pressure test the ductile iron pipe. Furthermore, no extra compensation shall be paid to the Contractor for:

1. Furnishing and installing brass, dry main plugs at the locations of all removed sample taps, or
2. Removing existing "end of line" or blow off valves after the pipeline has been hydrostatically tested and prior to connecting the newly installed pipeline to the existing water main.

All temporary materials or materials not remaining in the ground after the completion of the disinfection and pressure testing shall remain the property of the Contractor.

The pipe quantities to be paid for under this section shall be based on the size and the horizontal distance in linear feet of ductile iron pipe measured along the top centerline of the pipe in place complete and acceptable to the City of Tampa Water Department Engineer.

Payment shall be made under:

<u>Item No.</u>	<u>Description</u>	<u>Unit</u>
2101	Furnish and install 16" ductile iron pipe	LF
2102	Furnish and install 30" ductile iron pipe	LF
2103	Furnish and install 30" ductile iron flanged pipe w 6" outlet	EA

C2.20 Casing Installation

The Contractor shall provide all labor, equipment and materials to furnish and install steel casing pipe. The installation of steel casing pipe shall include, but may not be limited to:

1. Excavating the jacking and recovery pits;
2. Furnish the Design of Protective Systems for boring & receiving pits as follows:

Support systems, shield systems, and other protective systems to be utilized for the boring and receiving pits at the following jack and bore locations shall be approved by a

registered professional engineer:

- a. 13th Street under Busch Boulevard and the CSX railroad track as shown on sheet 12,
- b. Bougainvillea Avenue under S.R. 45/North Nebraska Avenue as shown on sheet 21, and
- c. 109th Avenue under S.R. 685/North Florida Avenue as shown on sheet 27.

Designs shall be in written form and shall include the following:

- a. A plan indicating the sizes, types, and configurations of the materials to be used in the protective system; and
 - b. The identity of the registered professional engineer approving the design.
 - c. At least one copy of the design shall be maintained at the jobsite during construction of the protective system. After that time, the design may be stored off the jobsite.
- 3 Maintaining the jacking and recovery pits that shall include dewatering and sheeting and bracing where required or as directed by the Engineer;
 - 4 Protecting riding and walking public from accidents due to the pits.
 - 5 Scheduling a CSX inspector to monitor crossing the CSX rail on Busch Blvd;
 - 6 Scheduling a FDOT inspector to monitor crossing Florida Avenue, Nebraska Avenue and Busch Boulevard;
 - 7 Dewatering the roadway;
 - 8 Furnishing, cutting and full depth welding of the steel casing pipe;
 - 9 Jacking the steel casing pipe using a steering head to guide the auger to the locations specified on the drawings plan and profile;
 - 10 Furnishing and installing the approved pipe "casing spacers" on the carrier pipe;
 - 11 Furnishing and installing bulkheads inside the casing pipe ends to seal the inner space;
 - 12 Backfilling and compaction of jacking and recovery pits;
 - 13 Cleaning up and restoring the job site which shall include re-grading the terrain; and
 - 14 Removing and legally disposing all waste materials.

Compensation for installing the carrier pipe and restraints will be made under the appropriate Contract Pay Items.

Payment shall be made under:

<u>Item No.</u>	<u>Description</u>	<u>Unit</u>
2201	Furnish and install 24" OD steel casing pipe	LF

C3.00 THRUST RESTRAINT

The Contractor shall provide for all labor, equipment and materials to completely furnish and/or install mechanical device thrust restraint. The installation of the thrust restraint shall include but not be limited to:

1. Excavating the trench;
2. Maintaining the trench which shall include dewatering and bracing and sheeting where

- required or as directed by the Engineer;
3. Furnishing and installing approved wedge action restraint fitting or flanged-joint restraints;
 5. Furnishing wedge action push-on gaskets where noted on the plans;
 6. Furnishing and Installing approved restraining devices on existing pipe joints; and
 7. Backfilling and compacting the trench;
 8. Cleaning up and restoring the job site which shall include re-grading the terrain; and
 9. Removing and legally disposing all waste materials.

Payment shall be made under:

<u>Item No.</u>	<u>Description</u>	<u>Unit</u>
3001	Furnish and install 16" wedge-action restraint	EA
3002	Furnish and install 30" wedge-action restraint	EA
3003	Furnish 16" push-on wedge action restraint gaskets	EA

C4.00 FITTINGS

The Contractor shall provide all labor and equipment to completely furnish and install tees, bends, sleeves, or reducers, as required. The installation of ductile iron fittings shall include, but not be limited to:

1. Excavating the trench;
2. Maintaining the trench which shall include dewatering and bracing and sheeting where required or as directed by the Engineer;
3. Furnishing and installing the appropriate fitting; and
4. Backfilling and compacting the trench.
5. Cleaning up and restoring the job site which shall include re-grading the terrain; and
6. Removing and legally disposing all waste materials

Payment will be made for the number of each size and type of fittings furnished and installed and incorporated into the piping system complete, working, and operating to the satisfaction of the Engineer.

Payment shall be made under:

<u>Item No.</u>	<u>Description</u>	<u>Unit</u>
4001	Furnish and install 16" Ductile Iron bend or sleeve	EA
4002	Furnish and install 30" Ductile Iron bend or sleeve	EA
4003	Furnish and install 30" Ductile Iron tee	EA

C5.00 VALVES

The Contractor shall provide all labor, equipment and materials to completely furnish and install 16-inch gate valves. The valve installation shall include, but may not be limited to:

1. Excavating the trench;
2. Maintaining the trench that shall include dewatering and bracing and sheeting where required or as directed by the Engineer;

3. Furnish and install a gate valve in a mainline of DIP, CIP or PVC with a valve box or a tapping valve on a tapping sleeve with a valve box;
4. Furnishing, forming and pouring a 6-inch thick concrete pad around each valve box in non-paved areas;
5. Furnishing paint and painting valve cover clary sage green;
6. Backfilling and compacting the trench;
7. Cleaning up and restoring the job site which shall include re-grading the terrain; and
8. Removing and legally disposing all waste materials

Payment shall be made for the number of each size valve and valve box installed and incorporated into the piping system complete, working and operating to the satisfaction of the Engineer.

Payment shall be made under:

<u>Item No.</u>	<u>Description</u>	<u>Unit</u>
5001	Furnish and install 16" Gate Valve and Box	EA
5002	Furnish and install 30" Butterfly Valve and Box	EA

C6.00 COMBINATION AIR VACUUM/AIR RELEASE VALVES

The Contractor shall provide all labor, equipment and materials and shall remove and dispose of all waste material to:

1. Excavating the trench;
2. Maintaining the trench that shall include dewatering and bracing and sheeting where required or as directed by the Engineer;
3. Furnish and install complete and functional combination air release/vacuum valve assembly in a standard Pedlock Fiber Optic Pedestal in accordance with the Standard Details on pipeline of various sizes and depths;
4. Backfilling and compacting the trench;
5. Cleaning up and restoring the job site which shall include re-grading the terrain; and
6. Removing and legally disposing all waste materials

Payment shall be made under:

<u>Item No.</u>	<u>Description</u>	<u>Unit</u>
6001	Furnish and install 2" air vacuum/release valve assembly (on new 16")	EA
6002	Furnish and install 2" air vacuum/release valve assembly (on existing 30")	EA
6003	Furnish and install 3" air vacuum/release valve assembly	EA
6004	Furnish and install 6" air vacuum/release valve assembly	EA

C7.00 Restoration And Miscellaneous Incidental Items

General

The Contractor shall furnish all labor, equipment, and materials to restore the

construction area to an equal or better condition than that which existed prior to construction.

The Contractor shall not be compensated for restoration outside of the maximum pay limits that are defined as:

Maximum pay limits = Nominal Pipe Diameter (D) + 1 foot + 2 times the depth of cover (for mains in trenches 0-5' deep).

or = D + 3 times the depth of cover (for mains in trenches greater than 5' deep)

If an area greater than the maximum pay limit is disturbed during construction, the Contractor shall restore the disturbed area outside pay limits to a condition which is equal to or better than the original without additional compensation. The only exception to this shall involve milling and overlaying operations. The Contractor shall mill and overlay to those limits as directed by the Engineer and shall be compensated in conformance with the appropriate pay items for actual quantities furnished and installed.

As stated previously, upon final payment by the Department, the Contractor shall maintain the surface of the unpaved trenches, shrubbery, trees, fences, sod, and other surfaces disturbed for a period of 6 months thereafter and shall maintain the repaved areas, curbs, gutters, and sidewalks, if replaced by the Contractor for one year after final acceptance of the respective item. The cost of maintaining the restored areas shall be incidental to the cost of restoring the areas disturbed by the Contractor. These costs shall be prorated and included in the cost for the respective contract pay item.

C7.10 Pavement

The Contractor shall provide all labor, equipment and materials to remove and restore pavement and pavement bases that were cut and removed during the course of the pipeline construction. Pavement and pavement base restoration shall include roadways, driveways, parking lots, etc. Under this section, payment shall be made for:

1. Furnishing, placing, grading, and compacting approved crushed concrete base;
2. Furnishing, placing, grading, and compacting approved asphalt base course, ABC-3;
3. Furnishing, placing, grading and compacting approved "Type S-1" or asphaltic concrete surface course;
4. Restoring 6" thick concrete driveway;
5. Furnishing and installing roadway striping;
6. Furnishing, placing, and grading Type S-III asphaltic concrete overlay;
7. Mechanical milling of 1-inch of existing asphalt including proper disposal of the milled material;
8. Mobilization required for mechanical milling operations;
9. Furnishing and installing signalization loops as specified and directed by the

- Engineer;
10. Furnishing and installing work zone signs;
 11. Furnishing and installing traffic control devices to right-of-way permit requirements;
 12. Removing, transporting and disposing of pavement, concrete curb, asphaltic curb and other items removed during construction;
 13. Cleaning up and restoring the job site which shall include re-grading the terrain; and
 14. Removing and legally disposing of all waste materials.

All surface restoration shall be as directed by the Engineer or the regulatory agency having jurisdiction over the roadway. All areas requiring pavement restoration shall be saw cut prior to construction pavement removal. The costs to mechanically saw cut pavement joints and the cost to replace all striping and pavement markers are considered incidental to pavement restoration and should be included in the cost.

Asphalt shall be measured for payment based on the number of tons of asphalt furnished and installed. All pavement, concrete curb, asphaltic concrete curb or other items removed during the course of pipeline construction shall be disposed of by the Contractor in a manner satisfactory to the Department. The cost of removal and disposal associated with all items shall be included in the assigned restoration item.

City street pavement shall be in accordance with of Tampa’s PAVEMENT/RIGHT OF WAY RESTORATION REQUIREMENTS – REV-2009 guidelines. See Technical specification T4.07.

Mobilization for milling shall only be paid for milling operations and shall only be paid three times unless otherwise approved in advance by the Engineer. Milling shall be made in thickness increments of one inch and shall include proper disposal of the milled material.

The Contractor shall furnish all labor, materials and equipment, necessary to replace and maintain complete the traffic signalization loops as specified and directed by the Engineer. The work includes all saw-cutting of pavement, placement of loop wires and lead-in cables, non-metallic wire hold downs, wire identification tags and sealants, splicing and termination strips, testing and all other work incidental to the installation of a signalization loop complete in place. All signalization loops shall conform to the requirements of the latest edition of the Florida Department of Transportation Standard Specifications for Road and Bridge Construction. Payment for traffic signalization loops will be made at the appropriate contract item unit price per signalization loop installed.

Payment shall be made under:

<u>Item No.</u>	<u>Description</u>	<u>Unit</u>
-----------------	--------------------	-------------

7101	Furnish, place, and compact Limerock	CY
7102	Furnish and install asphalt concrete surface Type S-1	TN
7103	Furnish, place and grade Type S-III asphaltic concrete overlay	TN
7104	Mobilization to perform milling operations	EA
7105	Mechanical milling of asphalt roadways in 1-inch increments	SY-IN
7106	Furnish and install 6" thick concrete driveway	SY
7107	Furnish and install signalization loops	EA
7108	Furnish and install Work Zone Signs	EA
7111	Furnish and install Barricades (Temporary – Type II)	EA
7112	Furnish and install Barricades (Temporary Type III) (6")	EA
7113	Furnish and install Advance Warning Arrow Panel	EA
7114	Furnish and install High Intensity Flashing Lights (Temporary-Type B)	EA
7115	Furnish and install Variable Message Sign (Temporary)	EA

C7.20 ROADSIDE RESTORATION

The Contractor shall furnish all labor, equipment, and materials to restore the construction area to an equal or better condition than that which existed prior to construction. The Contractor shall not be compensated for restoration outside of the maximum pay limits that are defined as:

$$\begin{aligned} \text{Maximum pay limits} &= \text{Nominal Pipe Diameter (D) + 1 foot + 2 times} \\ &\quad \text{the depth of cover (for mains in trenches 0-5'} \\ &\quad \text{deep).} \\ &\text{or} \\ &= \text{D + 3 times the depth of cover (for mains in} \\ &\quad \text{trenches greater than 5' deep)} \end{aligned}$$

Calculations for the pay items shall be made for compacted material within the trench, not the yards of material delivered to the work site.

If an area greater than the maximum pay limit is disturbed during construction, the Contractor shall restore the disturbed area outside pay limits to a condition which is equal to or better than the original without additional compensation.

The Contractor shall provide for all labor, equipment and materials to restore the roadside areas disturbed during the course of the pipeline construction. Under this section, payment shall be made for:

1. Restoring typical concrete curb and gutter including stabilization of sub-base and installation of curb pads;
2. Restoring stone or pre-cast curb;
3. Furnishing and placing asphaltic concrete curb;
4. Remove and restoring 4-inch thick concrete sidewalk, including applicable sidewalk ramps;
5. Restoring the roadside areas with approved sod. Restoring the roadside area

- and ditch bottoms and sides with sod shall include furnishing, grading, and placing the sod; and
6. Furnishing and installing detectable warning on walking surfaces as directed by Engineer. The detectable warning surface will conform to the Florida Department of Transportation Standard Specification for Road and Bridge Construction, current edition. The detectable warnings shall be installed in conformance with FDOT Standard Indexes 304 and 310 or in conformance with the requirements of the right-of-way regulatory agency with responsibility of the affected right-of-way.
 7. Furnishing professional quality video photography of pre-construction site conditions along proposed pipeline route as specified in these contract documents and as required.
 8. Cleaning up and restoring the job site which shall include re-grading the terrain; and
 9. Removing and legally disposing of all waste materials.

Payment for curb and sidewalk associated with pedestrian access ramps will be made under the appropriate sidewalk and curb pay items. Sidewalk and curb replacement pay quantities shall have maximum limits as specified in these documents, as shown on the plans or as directed by the Engineer. All linear foot units shall be measures along the curb line. In all cases, the sod or seed placed is to conform in kind to the existing at the particular location.

Payment shall be made under:

Item No.	Description	Unit
7201	Grade and sod roadside, ditch bottoms and sides	SY
7202	Furnish and install Type "D" concrete curb	LF
7203	Video Photography	LF

C8.00 Project Sign

Project signs shall be furnished for each project as directed by the engineer. The Contractor shall furnish and install a project sign which conforms to the Standard Detail at a location directed by the Engineer at least five (5) working days in advance of the start of construction. The unit price will include the cost of all labor, equipment and materials to furnish and install a new sign, or to re-letter and install a sign previously used elsewhere under this contract. The price shall also include the cost to remove and properly dispose of the sign once the work has been completed and accepted by the City of Tampa. The area on which the sign was placed shall be restored to original condition. This restoration shall be included in the cost of the sign.

Payment shall be made under:

Item No.	Description	Unit
----------	-------------	------

8000 Furnish and install a new sign as directed by the Engineer EA

C9.00 Contingency Allowance

The contingency allowance shall be used by the City of Tampa as directed by the Engineer. Payment shall be made as a lump sum to pay for furnishing and installing items not listed in the Contract. When directed to provide materials and services not listed in the contract, the Contractor shall provide an estimate of the cost as a lump sum item. The estimate shall include quotes for quantities of materials, subcontractors and equipment. To obtain payment, the Contractor shall provide an invoice listing the quantities the materials, subcontractors, equipment along with the lump sum price. The Engineer may request a cost estimate for a contingency item from the Contractor prior to construction.

Payment shall be made under:

Item No.	Description	Unit
9000	Contingency Allowance	LS

* * *

END CONTRACT PAY ITEMS

CITY OF TAMPA

CURIOSITY CREEK

DETENTION POND F IOOC

ROADWAY AND TRAFFIC DESIGN STANDARDS
(F.D.O.T. BOOKLET, DATED JAN. 1987 &
CITY OF TAMPA STANDARD DRAWINGS)

<u>INDEX NUMBER</u>	<u>SHEET DESCRIPTION</u>
DPW D-2	STANDARD INLETS TYPES 1,2,3,"D""E""H"
DPW D-13	MISCELLANEOUS DRAINAGE STRUCTURES
DPW P-3	CURBS - GUTTERS / JOINT DETAILS
DPW P-4	DRIVEWAY DETAILS
DOT 200	STRUCTURE BOTTOMS - TYPE J AND P
DOT 201	SUPPLEMENTARY DETAILS FOR MANHOLES & INLETS
DOT 273	SIDE DRAIN MITERED END SECTION
DOT 280	MISCELLANEOUS DRAINAGE DETAILS (SHEET 2 OF 3)
DOT 452	FENCE TYPE B
DOT 102	BALED HAY OR STRAW BARRIERS AND SILT FENCES

THIS CONTRACT PLAN SET INCLUDES INDEX OF PLANS

<u>SHEET NUMBER</u>	<u>SHEET DESCRIPTION</u>
1	COVER SHEET
2	DRAINAGE MAP
3	GENERAL INFORMATION AND LEGEND
4-6	PLAN VIEW SHEETS
7-11	CROSS SECTION SHEETS
13-20	PLAN & PROFILE (OFF SITE AREAS)
21-22	DETAIL SHEETS
23	SOIL BORINGS
(SHEET 12 DELETED)	



VICINITY MAP
N. T. S.

PREPARED BY:
**FLORIDA LAND DESIGN AND
ENGINEERING, INC.**

Edward D. McGuire 7/25/88
EDWARD D. MCGUIRE , P.E.

CONTRACT 1-89

Department of Public Works
City of Tampa, Florida

AS-BUILT PLANS PREPARED FROM COMPLETED
CONSTRUCTION INFORMATION SUBMITTED BY
CONSTRUCTION ENGINEER AND REVIEWED FOR
CONFORMATION OF GENERAL SITE CONDITIONS

Project Engineer _____ Date _____
Construction Engineer _____ Date _____

APPROVED BY

Jack P. Morris
JACK P. MORRIS, P.E.
DIRECTOR
DEPARTMENT OF SANITARY SEWERS

FILE NO. PW 86-100

JOB NO. 5377

TBM #2 Elev = 28.69
 7' Cut in E/D/W to Res. # 220, 109th Ave.,
 30'(C) South of E 109th Ave. & 50'(C) East of
 E Ola Ave.

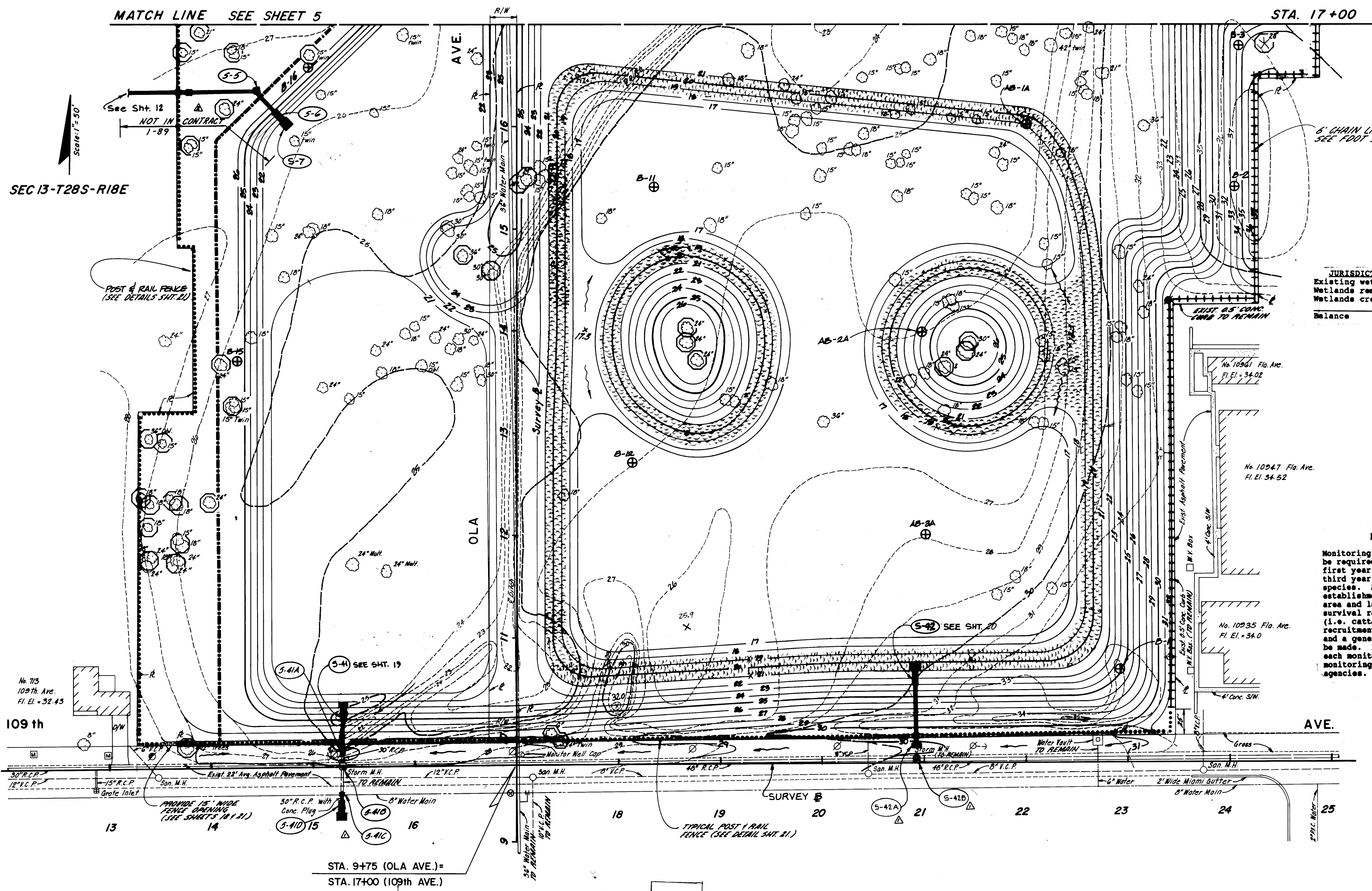

6' CHAIN LINK FENCE "TYPE B", GREEN VINYL COATED
 SEE FOOT INDEX No. 452.

JURISDICTIONAL WETLANDS ACREAGE SUMMARY

Existing wetlands, sinkholes and ditch:	2.215 acres
Wetlands removed (ditch area):	1.217 acres
Wetlands created	1.410 acres
Balance	2.408 acres

MONITORING AND MAINTENANCE PROGRAM

Monitoring of the mitigation areas for plant survival will be required for three years. Quarterly monitoring for the first year and semi-annual monitoring for the second and third year will be required to ensure 85% survival of marsh species. A regular maintenance program will ensure the establishment and stabilization of this wetland mitigation area and lake littoral shelves. During these evaluations, survival rates will be observed, nuisance vegetation removed (i.e. cattail, primrose willow, dog fennel, etc.), natural recruitment of vegetation observed, water levels recorded and a general assessment of the viability of the system will be made. Photographic documentation will be conducted at each monitoring event. Report will be submitted after each monitoring event by the developer to the appropriate agencies.

AS-BUILT
 REVIEWED BY: _____ DATE: _____

PUBLIC WORKS DEPARTMENT
 CITY OF TAMPA, FLORIDA

**CURIOSITY CREEK
 DETENTION BASIN**

APPROVED BY
Jack P. Morris
JACK P. MORRIS, P.E.
 DIRECTOR
 DEPARTMENT OF SANITARY SEWERS

FLD&E
 Florida Land Design & Engineering, Inc.
 planning / engineering / landscape architecture / surveying
 10000 Bruce B. Downs Blvd., Suite 1000, Tampa, FL 33613-2800
 Phone: (813) 973-1100 Fax: (813) 973-1101

Designed: CAL Date: 3-88 Drawn: LMK Date: 4-88 Checked: TFS Date: 3-88	Reviewed: BEJ Date: 3-88 Approved: EDM Date: 3-88 Scale: 1" = 50'
Field Book: 85-36, 37 & 38	FILE No. PW06-100 JOB No. 5377 SHEET 4 of 23

T.B.M. #5 Elev. = 30.36
 1' cut in South Edge Conc. D/W to Res. # 11501
 Ola Ave., 45' (±) East of E Ola Ave. & 50' (±)
 North of E 115th Ave.

SEC 13-T28S-R18E

Scale = 1" = 50'

- 5-35 CONST 10' x 10' TURF BLOCK PAD
- 5-36 STA 23+28 (20' LT.) CONST. M.E.S. INDEX No. 273 FL. EL. = 22.00
- 5-37 STA 23+28 (20' LT.) CONST. TYPE JTT ALI B M.H. (6'x6') INDEX No. 200 TOP EL. = 23.00 FL. EL. = 22.89 (M) FL. EL. = 22.89 (M) FL. EL. = 22.04 (S)
- 5-38 STA 23+28 (20' LT.) CONST. CONCRETE JACKET DRAW D-13 CONNECT TO EX. 30" R.C.P. FL. EL. = 23.03
- 5-39 STA 31+08 (20' LT.) CONST. TYPE JTT ALI A M.H. INDEX No. 200 TOP EL. = 31.00 FL. EL. = 24.33 DO NOT CONNECT 30" R.C.P. TO THE WEST TO THE M.H. PLUG 30" R.C.P. TO THE WEST
- 5-17 CONST 10' x 10' TURF BLOCK PAD
- 5-18 CONST MITERED END SECTION INDEX No. 273 FL. EL. = 22.23
- 5-17 CONST. TYPE JTT ALI B M.H. INDEX No. 200, 201 TOP EL. = 23.00 FL. EL. = 22.89 (M) 22.86 FL. EL. = 22.06 (S) 22.16
- 5-16 CONNECT TO EXIST. 18" R.C.P. FL. EL. = 22.23 WITH STD CONCRETE JACKET DRW D-15

MATCH LINE SEE SHEET 5

STA. 24+00

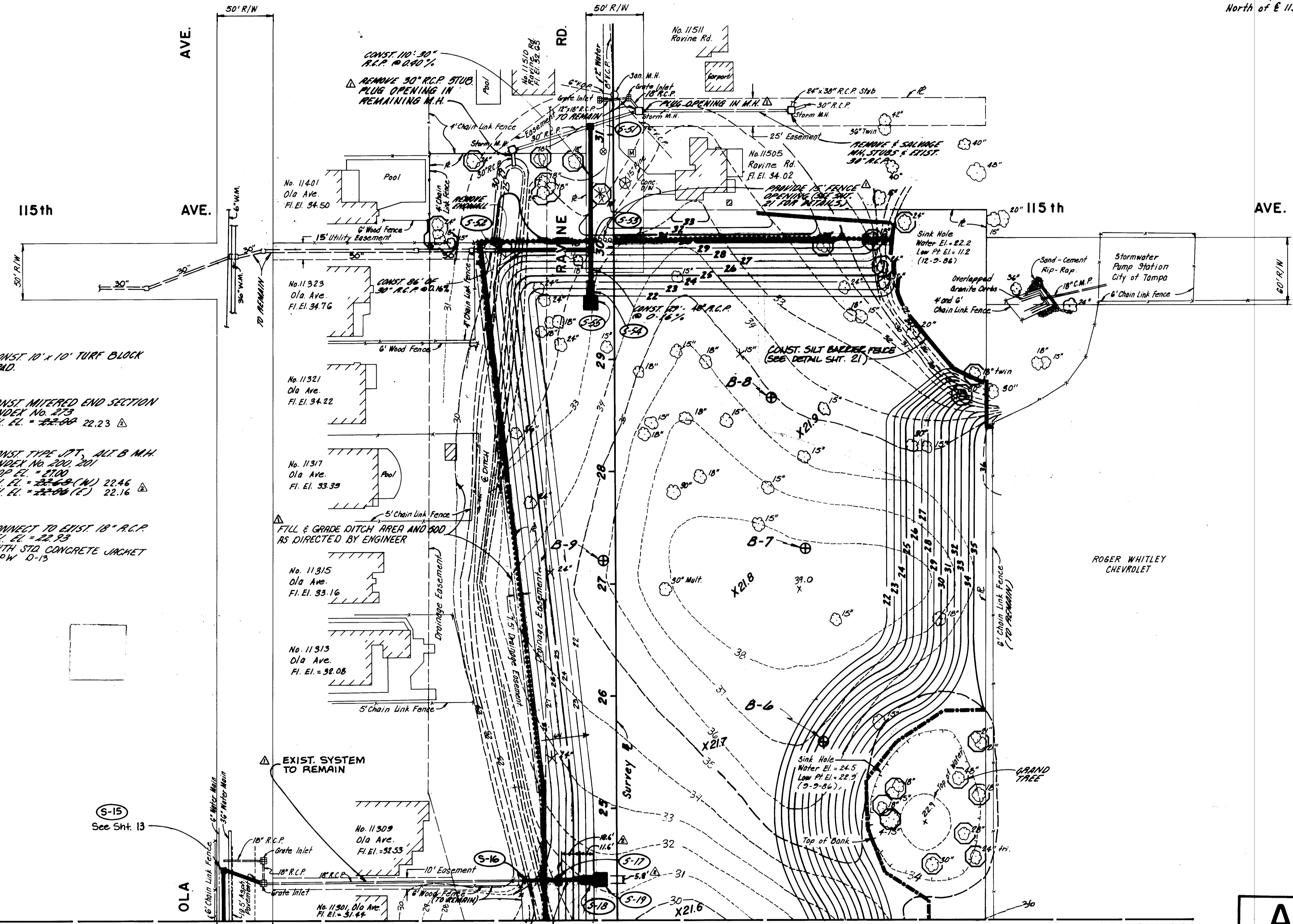

AS-BUILT
 REVIEWED BY _____ DATE _____

PUBLIC WORKS DEPARTMENT
 CITY OF TAMPA, FLORIDA

**CURIOSITY CREEK
 DETENTION BASIN**

APPROVED BY
Jack P. Morris
JACK P. MORRIS, P.E.
 DIRECTOR
 DEPARTMENT OF SANITARY SEWERS

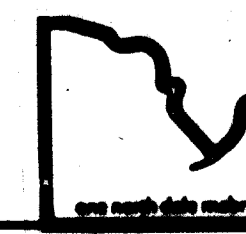

FLD&E
 Florida Land Design & Engineering, Inc.
 planning / engineering / landscape architecture / surveying

Designed: CAL	Date: 3-88	Drawn: JDB/LL	Date: 3-88	Checked: TFS	Date: 3-88
Reviewed: BEJ	Date: 3-88	Approved: EDM	Date: 3-88	Scale: 1" = 50'	
Field Book: 86-36, 37 & 38					
FILE No. PW86-100	JOB No. 5377				SHEET 6 of 23

No.	Date	REVISION
1	12-01-92	As-Built Condition Shows
2	1-24-93	General Design Revisions

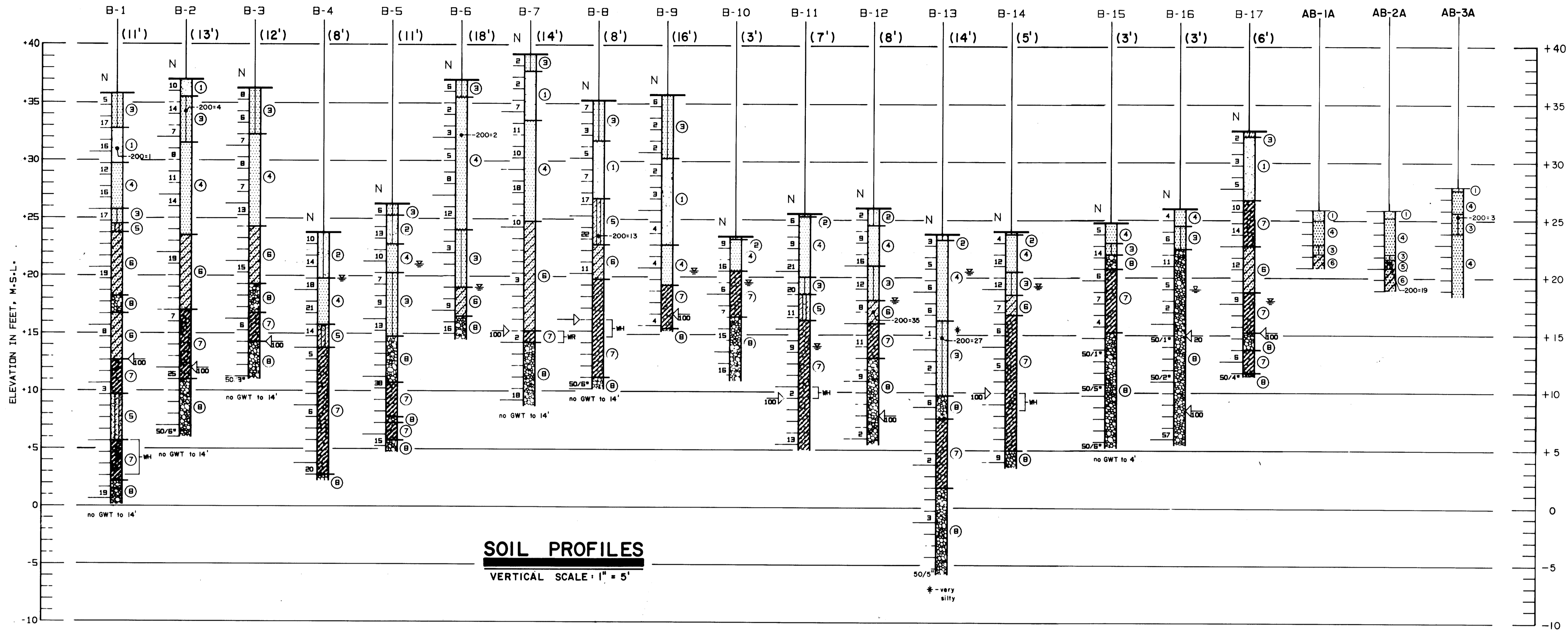

SOIL PROFILES
VERTICAL SCALE: 1" = 5'

LEGEND

- ① Light yellow-brown fine SAND (SP)
 - ② Dark gray to gray fine SAND to slightly silty fine SAND (SP/SP-SM)
 - ③ Brown to dark brown fine SAND to slightly silty fine SAND (SP/SP-SM)
 - ④ Light brown to light tan fine SAND (SP)
 - ⑤ Brown to light brown silty fine SAND to slightly clayey fine SAND (SM/SM-SC)
 - ⑥ Greenish-gray sometimes mottled orange-brown clayey fine SAND to sandy CLAY (SC-CH)
 - ⑦ Greenish-gray to blue-green or gray CLAY with limestone fragments (CH)
 - ⑧ Light gray to white weathered LIMESTONE sometimes trace of clay
- = Groundwater level, December 1986
 SP Unified Soil Classification group symbol as determined by visual examination
 N SPT "N" value in blows/foot
 50/3" Fifty blows for three inches
 ◀ Loss of circulation (%)
 WH Fell under weight of rod & hammer
 200 Fines passing No. 200 sieve (%)
 ⊙ Approximate SPT boring location
 WR Fell under weight of rod
 (5') Depth of "Most Suitable Fill"
 Shallow groundwater level was not encountered in borings AB-1A, AB-2A and AB-3A.

BORING ID

LOCATION

B-1	N1065 X E1290
B-2	N1540 X E1505
B-3	N1680 X E1500
B-4	N2030 X E1240
B-5	N2295 X E1155
B-6	N2560 X E1217
B-7	N2730 X E1205
B-8	N2865 X E1170
B-9	N2720 X E1025
B-10	N1800 X E1100
B-11	N1540 X E835
B-12	N1270 X E815
B-13	N2170 X E900
B-14	N2030 X E890
B-15	N1370 X E425
B-16	N1660 X E500
B-17	N1950 X E400
AB-1A	N1600 X E1200
AB-2A	N1400 X E1100
AB-3A	N1200 X E1100

△ PREPARED FOR CITY'S USE ONLY. BIDDERS SHALL NOT RELY ON THE ACCURACY OF ANY INFORMATION CONTAINED HEREIN, BUT SHALL BE RESPONSIBLE FOR ADHERING TO THE TERMS OF SECTION 1-2.01, OF THE CONTRACT SPECIFICATIONS.

Edna D. M...
7/25/88

SOILS STUDY
CURIOSITY CREEK RETENTION BASIN
TAMPA, FLORIDA

JAMMAL & ASSOCIATES, INC. Consulting Engineers

DATE: JAN. 87 PROJ. NO: 86-30472 SHEET 1 OF 1

FLD&E
Florida Land Design & Engineering, Inc.
planning / engineering / landscape architecture / surveying
one north dale mabry, suite seven hundred tampa, florida 33609 tampa, florida (813) 875-1115 pinellas (813) 443-6827

APPROVED BY
Jack P. Morris
JACK P. MORRIS, P.E.
DIRECTOR
DEPARTMENT OF SANITARY SEWERS

PUBLIC WORKS DEPARTMENT
CITY OF TAMPA, FLORIDA

**CURIOSITY CREEK
SOIL BORINGS**

Designed: N/A Date:	Drawn: CQD Date: 12-87	Checked: N/A Date:
Reviewed: N/A Date:	Approved: N/A Date:	Scale: N/A
Field Book		
FILE NO. FW86-100	JOB NO. 5377	SHEET 23 of 23

Geotechnical Investigation Report

Blue Sink MFL Pump Station and Pipeline City of Tampa, Florida

Prepared for: **MWH**
1000 North Ashley Drive
Suite 1000
Tampa, Florida 33602

Prepared By:
MC Squared, Inc
5808 – A Breckenridge Parkway
Tampa, Florida 33610

Project No. T111001.216
April 2013





April 24, 2013

Mr. Kenneth J. Broom, PE
MWH
1000 North Ashley Drive, Suite 1000
Tampa, FL 33602

**Geotechnical Engineering Services Report
Blue Sink MFL Pump Station and Pipeline
City of Tampa, Florida
MC² Inc. Project No. T111001.216**

MC Squared, Inc. (MC²) has completed the geotechnical engineering services for the referenced project. This study was performed in general accordance with **MC²** revised proposal No. T111001.216 dated June 7 2012. The services were authorized through a subcontract agreement between **MC²** and **MWH**. The results of this exploration, together with our recommendations, are included in the accompanying report.

Often, because of design and construction details that occur on a project, questions arise concerning subsurface conditions. **MC²** will be pleased to continue our role as geotechnical consultants during the construction phase of this project to provide assistance with construction materials testing and inspection services and to verify that our recommendations are implemented.

We trust that this report will assist you in the design and construction of the proposed project. We appreciate the opportunity to be of service on this project. Should you have any questions, please do not hesitate to contact us.

Respectfully submitted,
MC²

Kermit Schmidt, PE
Vice President/Chief Engineer
Florida PE No. 45603

Joe DiStefano, PE
Vice President
Florida PE No. 31939

TABLE OF CONTENTS

1.0 PROJECT INFORMATION	2
1.1 PROJECT AUTHORIZATION.....	2
1.2 PROJECT DESCRIPTION	2
1.3 SCOPE OF WORK AND SERVICES	3
2.0 LABORATORY TESTING	5
2.1 SOIL CLASSIFICATION TESTING.....	5
2.2 PERCENT PASSING THE NO. 200 SIEVE.....	5
2.3 MOISTURE CONTENT	6
3.0 GENERAL SITE AND SUBSURFACE CONDITIONS	6
3.1 HILLSBOROUGH COUNTY SOIL SURVEY.....	6
3.2 REGIONAL GEOLOGY.....	7
3.3 SUBSURFACE EXPLORATION	8
3.4 SUBSURFACE CONDITIONS.....	10
3.5 GROUNDWATER INFORMATION.....	11
4.0 EVALUATION AND RECOMMENDATIONS	12
4.1 GENERAL	12
4.2 PIPELINE CONSIDERATIONS.....	12
4.3 PROPOSED PUMP STATION RECOMMENDATIONS	14
5.0 CONSTRUCTION CONSIDERATIONS	24
5.1 GENERAL	24
5.2 FILL PLACEMENT AND SUBGRADE PREPARATION.....	24
6.0 REPORT LIMITATIONS	25

APPENDIX A

Table 2 – Summary of Boring Locations, Groundwater Table and SHWT

Table 3 – Summary of Laboratory Test Results

Boring Location Plan – Sheets 1

Report of Core Borings (Soil Profiles) – Sheet 2

Cone Penetration Test (CPT) Results for boring CPT-1 – Sheet 3

APPENDIX B

Ground Penetrating Radar Survey Results

Test Procedures

1.0 PROJECT INFORMATION

1.1 PROJECT AUTHORIZATION

Authorization to proceed with this project was issued by **MHW** thru a subcontract agreement for services dated November 7, 2012. A formal contract has been executed between **MHW** and **MC²** for these services.

1.2 PROJECT DESCRIPTION

Project information has been provided by Mr. Kenneth Broome, PE of **MWH** through verbal and email communications. Based on our understanding, geotechnical engineering services are required to support the design for the following project components at this site in the City of Tampa, Florida.

Blue Sink MFL Pumping Station

The site is located approximately 500 west of the intersection of N Florida Avenue and W. 115th Avenue. The project consists of constructing a new L-shaped pump station and electrical room building (approximately 35' x 60'), along with the two (2) 16 inch HDPE suction pipes from the adjacent Blue Sink as well as an 18 inch HDPE discharge pipe across Blue Sink. Based on the drawings furnished to us, the foundation of the pump station room will be constructed at approximate elevations 25.0 to 30.0 while the electrical room will be constructed at grade or at the approximate elevation of 36.0 feet. As proposed, the structures will be supported on shallow foundations (strip footings and a mat foundation).

We have assumed that the bottom slab of the pump station will be poured monolithically and tied in with the lower portion of the walls. The load for the structure was not provided and we have assumed that it will be less than 1,000 psf.

Blue Sink Raw Water Main Pipeline

The proposed 18 inch HDPE Discharge Pipe will run west from the Blue Sink Pump Station and connect to a 16 inch raw water main east of Ravine Rd., at which point it will continue west and then south along the west side of the City of Tampa FC-100 Stormwater pond to its connection point in a City of Tampa designed 16 inch raw water main in 109th Ave., west of Florida Ave.

To assist with evaluating subsurface conditions, Ground Penetrating Radar (GPR) was performed at the proposed pump station site.

The recommendations provided in this report are based on this information. If any of the noted information is incorrect or has changed, please inform **MC²** so that we may amend the recommendations presented in this report, if appropriate or necessary.

1.3 SCOPE OF WORK AND SERVICES

Our geotechnical study began with a review of available subsurface data in the project vicinity including the USDA Hillsborough County Soil Survey and previous year(s) aerial photos of the site. The testing program consisted of the following services:

1. Conducted a visual reconnaissance of the project site. Determined boring locations by taping distances from known and/or identified reference points. Cleared utilities in the vicinity of the proposed boring locations.
2. Performed a Ground Penetrating Radar (GPR) survey to document the lateral continuity of soil layers around and beneath the proposed pump station and electrical building site (approx. 130 feet x 60 feet) to help characterize the geology of the site and to assist in promoting effective geotechnical engineering design and testing. The objective of the survey was an added measure to assess possible geologic features of interest in the area of proposed improvements. Based on our understanding, the Blue Sink site is located over a known cave system feeding Sulphur Springs and anomalies/potential karst activity may have a higher than normal probability in this area.
3. Reviewed the USDA Soil Survey for Hillsborough County and the USGS topographic maps. Determine boring locations by taping distances from boundaries.
4. Performed geotechnical explorations in the vicinity and at the proposed location of the new pump station and electric room as determined by **MWH**. Performed Standard Penetration Test Borings (SPT), Cone Penetrating Testing (CPT) and hand auger borings as follows:
 - a. Blue Sink MFL Pump Station- one (1) CPT boring to a depth of approximately 40 feet BGS within the footprint of the proposed structure. The final depth was reduced from the proposed 50 feet due to the soil conditions encountered.
 - b. Blue Sink Pipeline – two (2) SPT borings to a depth of 20 feet BGS and one (1) to a depth of 25 feet (extended 5 feet due to field

**Blue Sink MFL Pump Station & Pipeline
Hillsborough County, FL
MC² No. T111001.216**

conditions) along the pipeline route at locations as determined by the designers, **MWH**.

- c. In, addition, we performed five (5) hand auger borings to depths of 7.0 feet below the existing ground surface (BGS) along a segment of the proposed discharge pipe located west of the proposed pump station. These hand augers were performed to determine the presence or absence of shallow rock in these areas.
5. Visually examined all recovered soil samples in the laboratory and performed laboratory tests on select representative samples to develop the soil legend for the project using the Unified Soil Classification System, as appropriate. The laboratory testing included percent passing the No. 200 sieve and natural moisture content test determination.

The data was used in performing engineering evaluations, analyses, and for developing geotechnical recommendations in the following areas:

1. General assessment of area geology based on our past experience, study of geological literature and boring information.
2. General suitability of materials within the site for use as engineered fill and general backfill.
3. General location and description of potentially deleterious materials encountered in the borings, which may interfere with the proposed construction or performance, including existing fills or surficial organics. Special conditions such as expansive clays, peat, or pockets of highly compressible soils (if any) will be evaluated.
4. Discuss critical design and/or construction considerations based on the soil and groundwater conditions developed from the borings including excavation difficulties, dewatering and hard/dense soil conditions, etc. The information will be used to support design requirements for addressing the pipe thrust potential.
5. Address groundwater levels in the borings and estimate seasonal high groundwater. Provide recommendations for dewatering, if required.
6. Suitability and availability of materials on-site that may be moved during site grading for use as structural fill and as pipe backfill.

7. Pipeline recommendations.
8. Design parameters required for the project including the new pump station with associated improvements and pipeline. We have provided shallow foundation recommendations, including allowable bearing pressures, anticipated settlements and recommendations for construction which includes our findings and analysis.

The approximate boring locations are summarized in **Table 2** and shown on **Sheet 1** in **Appendix A**.

The scope of our services did not include an environmental assessment for determining the presence or absence of wetlands or hazardous or toxic materials in the soil, bedrock, groundwater, or air, on or below or around this site. Any statements in this report or on the boring logs regarding odors, colors, unusual or suspicious items or conditions are strictly for the information of our client.

2.0 LABORATORY TESTING

2.1 SOIL CLASSIFICATION TESTING

Representative soil samples collected from the SPT borings were visually reviewed in the laboratory by a geotechnical engineer to confirm the field classifications. The samples were classified and stratified in general accordance with the Unified Soil Classification System. Classification was based on visual observations with the results of the laboratory testing used to confirm the visual classification. Laboratory classification tests consisting of percent passing the No. 200 sieve and moisture content determinations were performed on select soil samples believed to be representative of the materials encountered. The test results are included adjacent to the soils boring profiles with a summary provided in **Table 3** in **Appendix A**.

2.2 PERCENT PASSING THE NO. 200 SIEVE

The wash gradation test measures the percentage of a dry soil sample passing the No. 200 sieve. By definition in the Unified Soil Classification System, the percentage by weight passing the No. 200 sieve is the silt and clay content. The amount of silt and clay in a soil influences its properties, including permeability, workability and suitability as fill. This test was performed in general accordance with ASTM D-1140 (Standard Test Methods for Amount of Material Finer than the No. 200 (75 μ m) Sieve).

2.3 MOISTURE CONTENT

The laboratory moisture content test consists of the determination of the percentage of moisture contents in selected samples in general accordance with ASTM test designation D-2216. Briefly, natural moisture content is determined by weighing a sample of the selected material and then drying it in a warm oven. Care is taken to use a gentle heat so as not to destroy any organics. The sample is then removed from the oven and reweighed. The difference of the two weights is the amount of moisture removed from the sample. The weight of the moisture divided by the weight of the dry soil sample is the percentage by weight of the moisture in the sample.

3.0 GENERAL SITE AND SUBSURFACE CONDITIONS

3.1 HILLSBOROUGH COUNTY SOIL SURVEY

The U.S. Department of Agriculture - Soil Conservation Service now known as the Natural Resources Conservation Service (NRCS), has mapped the shallow soils in this area of Hillsborough County. This information was outlined in a report titled The Soil Survey of Hillsborough County, Florida using Version 10, dated April 6, 2011. The aerial images were photographed in May 21, 2007. The Soil Survey describes the soils at the site as Myakka fine sand (mapping unit 29). Small areas of other soil types may be present within the mapping unit. A summary of soil properties is presented in **Table 1** below.

Table 1 Hillsborough County USDA Soil Survey						
Bor. No.	Map Symbol and Soil Name	USDA Texture	Depth (Feet)	Unified Class.	High Water Table	Permeability (In/Hr)
					Depth (feet)	
CPT-1	(61) Zolfo fine sand	Fine Sand	0 – 0.3	SP-SM	2.0-3.5	6.0 - 20.0
		Fine Sand	0.3-6.7	SP-SM,SM		0.6 – 2.0
B-1	(7) Candler fine sand	Fine Sand	0 – 0.5	SP,SP-SM	>6.7	6.0 – 20.0
		Sand, Fine Sand	0.5-6.0	SP,SP-SM		6.0 – 20.0

**Blue Sink MFL Pump Station & Pipeline
Hillsborough County, FL
MC² No. T111001.216**

Table 1 Hillsborough County USDA Soil Survey						
Bor. No.	Map Symbol and Soil Name	USDA Texture	Depth (Feet)	Unified Class.	High Water Table	Permeability (In/Hr)
					Depth (feet)	
		Sand, fine sand	6.0-6.7	SP-SM		6.0 – 20.0
B-2	(60) Winder fine sand, frequently flooded	Fine sand	0 - 1.2	SP,SP-SM	0.0 – 1.0	6.0 – 20.0
		Loamy Sand, Sandy Loam	1.2-1.4	SM		0.2 – 0.6
		Sandy loam, sandy clay loam	1.4-2.8	SM, SM-SC, SC		<0.2
		Fine sand, loamy sand	2.8- 6.7	SP. SP-SM. SM		6.0 – 20.0
B-3	(3) Archbold fine sand	Fine Sand	0-0.3	SP	3.5-6.0	>20.0
		Sand, Fine Sand	0.3-6.7	SP		
AB-1 thru AB-5	(61) Zolfo fine sand	Fine Sand	0 – 0.3	SP-SM	2.0-3.5	6.0 - 20.0
		Fine Sand	0.3-6.7	SP-SM,SM		0.6 – 2.0

3.2 REGIONAL GEOLOGY

A review of Florida Geological Survey, Report of Investigations No. 25, dated 1961 prepared by the United States Geological Survey (USGS) revealed that Hillsborough County is in the Floridian section of the Atlantic Coastal Plain. The notable physiographic features of the area are related to ancient seas, which once covered the region. Relict shorelines are evidenced by subtle linear escarpments, which have not been significantly altered by fluvial (river) processes in much of the area. Four ancient shorelines are preserved in Hillsborough County. The Pamlico, Talbot, Penholoway, and Wicomico shorelines stand at or near 25, 42, 70 and 100 feet above present mean sea level (MSL),

respectively.

C. Wythe Cooke included the western and southern parts of the County in the Coastal Lowlands and the eastern part in the Central Highlands. The Coastal Lowlands are low, nearly level plains that lie next to the coast. The Central Highlands are the gently undulating to rolling areas in the eastern part of the County.

In the southwestern part of the County, Tampa Bay extends for a considerable distance inland. Its northern section is separated into Old Tampa Bay and Hillsborough Bay by a peninsula that extends southward from Tampa.

Large, nearly level plains, commonly called flatwoods, are in the western, southern, and northeastern parts of the County. These plains rise gradually from the coast to elevations of more than 100 feet in the eastern part of the County. Numerous intermittent ponds, swamps, and marshes and a few permanent lakes are in the flatwood areas. Many permanent lakes and intermittent ponds are in the northwestern and north-central parts of the County. Some of the larger lakes are Lake Thonotosassa, Lake Valrico, Mango Lake, Keystone Lake, and Lake Magdalene. Along the coast, elevations in the County range from sea level to about 144 feet at a point about 3.4 miles east of Plant City. Tampa is at an elevation of about 19 feet.

The surface drainage is toward Old Tampa Bay, Hillsborough Bay, and Tampa Bay. The principal streams are the Hillsborough, Alafia, and Little Manatee Rivers and Rocky, Sweetwater, Sixmile, and Bullfrog Creeks. Many ditches, canals and small bays extend inland from the coast for short distances.

Drainage is low on the flatwoods. Drainage provided by the depressions is made up of swamps and sloughs and by the few large streams that pass through the areas. The depressions contain water during the wet season. During periods of low rainfall, these ponds may become dry. Portions of northwestern Hillsborough County are riddled with sinkholes. Many of the sinkhole lakes are in direct hydrologic contact with the underlying limestone formations due to breaches in the clay aquitard. Consequently, water levels fluctuate in response to the potentiometric surface of the Floridian Aquifer.

3.3 Subsurface Exploration

3.3.1 General

The subsurface conditions for the project were explored by performing one (1) Cone Penetration Test (CPT) extending to approximately 40 feet at the proposed pump station and electric room site, three (3) SPT borings drilled to depths ranging from 20 to 25 feet

**Blue Sink MFL Pump Station & Pipeline
Hillsborough County, FL
MC² No. T111001.216**

below the existing ground surface along the proposed pipeline alignment and an additional five (5) hand auger borings to depths of 7.0 feet along the discharge pipe alignment. In addition, a GPR survey was also performed at the pump station site.

The CPT boring was conducted in accordance with ASTM standard D-5778 using a Hogantogler HT-D3546 brand. Collection of soil samples is not possible for this type of boring. The CPT method consists of advancing a cylindrical metal cone below ground surface at a constant and slow rate while subsurface data is obtained and recorded. The CPT boring log reports the cone tip resistance, friction ratio, pore pressure and soil classifications continuously for the soils encountered. Equivalent SPT “N” values are calculated via a 60% energy conversion based on procedures developed by Robertson. A Cone Penetration Testing Description and Summary is included in **Appendix A**.

The SPT borings were conducted in general accordance with ASTM D-1586 (Standard Test Method for Penetration Test and Split Barrel Sampling of Soils) using the rotary wash method, where a clay slurry (“drill mud” or “drill fluid”) was used to flush and stabilize the borehole. The initial 4 feet of the borings were advanced with a hand auger to further explore for underground utilities. Then, Standard Penetration sampling was performed at closely spaced intervals in the upper 10 feet and at 5-foot intervals thereafter. After seating the sampler 6 inches into the bottom of the borehole, the number of blows required to drive the sampler one foot further with a standard 140 pound hammer is known as the “N” value or blowcount. The blowcount has been empirically correlated to soil properties. The recovered samples were placed into containers and returned to our office for visual review.

The hand auger borings were performed by manually rotating a bucket auger into the ground in approximately 4 to 6 inch increments. As each soil type was encountered, its depth interval was recorded and representative samples taken for review in the laboratory. The hand auger borings were conducted in general accordance with ASTM D 1452 (Standard Practice for Soil Investigation and Sampling by Auger Borings).

Select soil samples were tested in the laboratory to determine material properties for our evaluation. Laboratory testing was accomplished in general accordance with ASTM standards. Laboratory test results are shown on the soil profiles and summarized in **Table 3** presented in **Appendix A**.

A GPR survey was also performed at the proposed pump station and electrical building site for the purpose of indentifying possible subsurface anomalies which may be related to buried karst or sinkhole activity. The GPR survey was conducted along a series of perpendicular transects spaced every 10 feet apart. Continuous mode data collection was performed with a Mala radar system using both a 250 and 500 megahertz (MHz) antenna in order to provide a reasonable balance of signal penetration and soil layer

resolution. The time range settings used provided information to a maximum estimated depth of 20 to 25 feet (BGS). The GPR survey was conducted in general accordance with ASTM D-6432 (Standard Guide for Using the Surface Ground Penetrating Radar Method for Subsurface Investigation). The results of the GPR survey are included in **Appendix B**.

3.4 SUBSURFACE CONDITIONS

The surface description (soil borings B-1 through B-3 and AB-1 through AB-5) discussed below is of a generalized nature to highlight the major subsurface stratification features and material characteristics. The soil profiles included in the **Report of Core Borings, Sheet 2 in Appendix A** should be reviewed for specific information at individual boring locations. These profiles include soil description, stratification, penetration resistances, and laboratory test results. The stratification shown on the boring profiles represents the conditions only at the actual boring location. Variations may occur and should be expected between boring locations.

The soil behavior type (classification) for CPT-1, using the CPT equipment was adopted from Robertson UBC-1983 and is shown on **Sheet 3 in Appendix A**.

- **Ground Penetrating Radar (GPR)** – In regards to potential sinkhole activity at the pump station site, no observed areas of significant downwarping or other indicators of possible disturbed soil were observed within the effective penetration depth of the GPR signal. Accordingly, based on the results, sinkhole activity sinkhole activity is not occurring at this site (see **Appendix B** for report).
- **Cone Penetration Test (CPT) – Boring CPT-1** – The ground surface elevation at the boring performed at the pump station site was estimated to be approximately 35.8 feet based on the topographic map provided by MWH. In general and based on soil classifications adopted from Robertson UBC-1983, the CPT boring encountered layers of loose to medium dense sands to silty sand (SP/SM) and firm sandy silt (ML) extending to depths of 16 feet (elev. 19.8 feet). From depths ranging from 16 feet (elev. 19.8 feet) to 21 feet (elev. 14.8 feet), the sands and silty sands (SP/SM) became medium dense. From depths ranging from 21(elev. 14.8) to 28 feet (elev. 7.8 feet), the borings entered soft to firm clayey silt to silty clay (ML/CL) and silty clay to clay (CL/CH). Next, the boring entered very stiff sandy silt to clayey silt (ML), silty sand to sandy silt (SM/ML) to a depth of about 38.0 feet (elev. -2.2 feet). The boring was terminated in very dense sand (SP) at a depth of 38.9 feet (elev. -.3.1 feet), which is interpreted as hard limestone.
- A summary table with the above information is included below.

**Blue Sink MFL Pump Station & Pipeline
Hillsborough County, FL
MC² No. T111001.216**

Depth (ft)	Elev. (ft)	Classification by Robertson 1990	Equivalent SPT "N" Values	Density (Consistency)	Comment
0 – 16	35.8 – 19.8	Sand, Silty Sand to Sandy Silt and Silt	7 – 13	Loose to medium dense Sands, stiff to very stiff Silts	
16 – 21	19.8 – 14.8	Sands and Silty Sands	10 – 25	Medium dense	
21 – 28	14.8 – 7.8	Clayey Silt to Silty Clay	4 – 10	Soft to firm	
28 – 38	7.8 – (-2.2)	Sandy Silt to Clayey Silt	4 – 45	Very soft to hard	
38 – 38.9	-2.2 to -3.1	Sand	45	Hard	Very dense Sand interpreted as hard Limestone at a depth of 38.0 feet

- SPT and hand auger borings (B-1 thru B-3 and AB-1 thru AB-5)** – In general, the borings encountered loose to medium dense fine sands, slightly silty fine sand to slightly clayey fine sand (SP/SP-SM/SP-SC) extending from the existing ground surface to depths of approximately 17 feet. Isolated layers of very loose (weigh of hammer) to medium dense clayey fine sands (SC), occasionally with some shell and rock fragments were encountered in boring AB-2. Boring B-3 entered an isolated layer of stiff calcareous clay (CL) ranging from depths of 12.0 to 17.5 feet. All the SPT borings were terminated in moderately hard to hard highly weathered limestone (LS) at depths ranging from 20 to 25 feet.

3.5 GROUNDWATER INFORMATION

As recorded immediately after our drilling operations, (January 28, thru February 7, 2013, which was and is typically a dry period), the groundwater level was encountered at depths ranging from 3.0 feet to greater than 7.0 feet. It should be noted that groundwater levels tend to fluctuate during periods of prolonged drought and extended rainfall and may be affected by man-made influences. In addition, a seasonal effect will also occur in which higher groundwater levels are normally recorded in rainy seasons. If the groundwater level is critical to design or construction, temporary observation wells should be installed along the alignment to

monitor groundwater fluctuations over a period of time and to permit more accurate determinations of wet and dry seasonal levels. We recommend that the Contractor determine the actual groundwater levels at the time of the construction to determine groundwater impact on the construction procedure. Groundwater table depths, where measured and encountered, are summarized along with the estimated seasonal high groundwater levels in **Table 2 in Appendix A**. These estimates are based on the soil stratigraphy, measured groundwater levels in the borings, USDA information and past experience. In areas where subsurface soil conditions were disturbed, normal indications such as “stain lines” were not evident.

4.0 EVALUATION AND RECOMMENDATIONS

4.1 GENERAL

The following design recommendations have been developed on the basis of the previously described project characteristics and subsurface conditions encountered. If there are any changes in these project criteria, including project location on the site, a review must be made by **MC²** to determine if any modifications in the recommendations will be required. The findings of such a review should be presented in a supplemental report.

Once final design plans and specifications are available, a general review by **MC²** is strongly recommended as a means to check that the evaluations made in preparation of this report are correct and that earthwork and foundation recommendations are properly interpreted and implemented.

4.2 PIPELINE CONSIDERATIONS

In general, the subsurface materials encountered at the boring locations (AB-1 thru AB-5 and B-1 thru B-3) consisted of loose fine sands and slightly silty fine sands to slightly clayey fine sands (SP/SP-SM/SP-SC) extending from the existing ground surface to depths ranging from 2.5 to 17 ft. Underlying the clean sands, the borings entered very loose to medium dense clayey fine sands (SC) extending to depths ranging from 12 to 22.0. Next, boring B-3 entered stiff calcareous clay (CL). Borings B-1 thru B-3 were terminated in soft to very hard highly weathered limestone (LS) at depths ranging from 20 to 25 feet.

Groundwater was measured at depths ranging from 3.0 to 4.0 feet in the SPT borings performed along the pipeline and not encountered within 7.0 feet in hand auger borings AB-1 thru AB-4. We anticipate the water table will be perched above a depth of 2.5 feet in area of hand auger boring AB-5.

**Blue Sink MFL Pump Station & Pipeline
Hillsborough County, FL
MC² No. T111001.216**

Settlement due to the presence of the pipeline should be minimal unless the subsoil is excessively disturbed during the installation, the phreatic surface is lowered for a substantial period of time, or if new loads are placed above or near the pipeline. Uplift pressure from the groundwater may be considered when the bottom of the pipeline is below the existing groundwater level.

Surface water and groundwater control will be necessary during construction of the pipeline to establish a stable sand bottom in which to bed the pipeline. Dewatering consisting of sump pumps and/or well pointing has been successful in the past. Dewatering must be conducted with care to avoid settlement of nearby structures, roads or utilities where applicable, and in such a manner that the areas possibly affected are as small as possible.

Depending upon shallow groundwater levels and the effectiveness of dewatering at the time of construction, seepage may enter the excavated trenches from the bottom and sides. Such seepage will act to loosen soils and create difficult working conditions. Groundwater levels should be determined immediately prior to construction. Shallow groundwater should be kept at least 12 inches below the working area to facilitate proper material placing and compaction. Organic soils and clayey soils should be removed (if encountered) within 24 inches from the bottom of the pipeline and replaced with properly compacted clean sands (SP/SP-SM/SP-SC).

A density of at least 95% of the modified Proctor maximum dry density (ASTM D-1557) is recommended for all fill materials and natural subgrade under the pipeline. The subgrade soils should be firm and stable prior to placement of the pipe. Once the pipeline is placed, it is recommended that backfill around the sides of the pipe be placed and compacted in equal lifts with a vibratory tamper in lifts not to exceed 6-inches (loose) to avoid laterally displacing the pipeline. Failure to compact the backfill will result in future settlement of the ground surface.

Pipeline backfill should be clean fine sand (free of clay, rubble, organics and debris) with less than 12% passing the No. 200 sieve and placed in compacted lifts. Some contractors like to place a gravel working bed in wet areas. Fine gravel, such as No. 57, and No. 67 stone may be used in limited areas. A continuous gravel bed should not be placed for the full pipe length to prevent a flow conduit under the pipeline. The gravel, where used, should be compacted and the compaction confirmed by visual observation.

The non-organic clean fine sands and slightly silty fine sands (SP/SP-SM/SP-SC) encountered at the project site with less than 12 percent passing the No. 200 sieve will be suitable for backfill.

It should be mentioned that water seepage through construction joints in the completed

pipeline may have a tendency to erode soil from around the pipeline. All such openings should be backed by a geotextile. An ultraviolet resistant high strength geotextile is recommended to prevent damage during construction.

4.3 PROPOSED PUMP STATION RECOMMENDATION

4.3.1 GENERAL SITE DEVELOPMENT CONSIDERATIONS

Due to the proximity of Blue Sink to the proposed pump station site, it was determined by the parties involved (City of Tampa, MWH and MC²) that a CPT boring would be performed at the pump station site in lieu of an SPT boring to reduce the risk of potential contamination to Blue Sink associated with grouting the borehole. As a result, soil samples and associated laboratory testing results were not obtained as is typically the case with SPT borings. The classifications of soils used in our analysis were adopted from Robertson, as previously noted herein. As a result, we recommend that a representative of MC², be on-site during the construction phase during excavation of the pump station to verify that the soils at the bearing level of the pump station are consistent with the assumptions made in our analysis.

We understand that about 7 to 12 feet of soil will be excavated to construct the pump station, electrical room and pipes. Based on the findings of our test boring, our understanding of the proposed structure, and our geotechnical engineering evaluation, monolithically poured shallow foundations and strip footings can be used for the proposed structures. However, there are some issues that will need to be addressed during design and construction especially with regards to the possible high groundwater table at the pump station location and loose/soft bearing soils.

The following sections further discuss specific geotechnical, foundation, design, and site grading concerns at these sites.

4.3.2 SITE PREPARATION

Prior to construction, the site should be stripped of any surface vegetation along with the organic soil layer found at 0 to 2 feet below ground surface (bgs) should be removed to a distance extending out at least 10 feet beyond the construction limits. Any areas requiring at-grade structures or areas requiring fill should be proofrolled with a heavily loaded dump truck, if accessible, to determine areas that may need additional removal of unsuitable bearing materials. In addition to stripping the site, the location of any existing underground utility lines within the construction area should be established. Provisions should then be

**Blue Sink MFL Pump Station & Pipeline
Hillsborough County, FL
MC² No. T111001.216**

made to relocate any interfering utility lines within the construction area to appropriate locations. In this regard, it should be noted that if abandoned underground pipes are not properly removed or plugged, they may serve as conduits for subsurface erosion which subsequently may result in excessive settlement. Any underground utility pipes not removed and being greater than 4 inches in diameter should be filled with "flowable" fill (lean concrete grout), while the ends of utility pipes less than 4 inches in diameter should be plugged with concrete to prevent the inadvertent introduction of fluids into the construction area. All utility lines that are removed outside of the excavation limits should be backfilled with acceptable fill material. Fill placement and subgrade preparation recommendations are presented in the Construction Considerations, Fill Placement, and Subgrade Preparation Section of this report.

Organic soils and clayey soils should be removed (if encountered) within 36 inches from the bottom of the pump station and electric room and replaced with properly compacted clean sands (SP/SP-SM/SP-SC).

4.3.3 Groundwater Considerations and Dewatering

Groundwater was not encountered within 7.0 feet of the ground surface in hand auger borings AB-1 and AB-2, which were performed just west of the proposed pump station site and near the location of the CPT-1 boring. The Soil Survey for Hillsborough County states that the site for the proposed pump station has a SHGWT levels ranging from 2.0 to 3.5 feet. The contractor should determine the actual groundwater levels at the time of construction. The contract documents should indicate that dewatering design and implementation is the sole responsibility of the Contractor and should also contain the performance criteria for assessing the effectiveness of the dewatering system actually installed. Dewatering consisting of cutoff walls, cased well points and/or vacuum well points or a combination thereof, should be designed and installed to lower the groundwater table at least to a depth of 3 or more feet below the bottom of the excavation. The dewatering should be maintained continuously (7 days per week/ 24 hours per day) throughout the construction period, until the backfill has reached the existing grade, and until sufficient structural weight is in place to resist uplift pressures due to the existing groundwater levels.

In addition to the primary dewatering system, pumping of miscellaneous inflow of water should be performed from sumps excavated and placed outside and just below the elevation of the proposed foundation area. Placement of compacted No. 57 stone wrapped in geo/filter fabric in the bottom of the excavation, beneath a pre-cast or cast in place concrete slab, will act as a medium for rainwater and groundwater inflows which will be pumped out of the recommended sump areas.

We recommend the use of 24 inches of No. 57 Stone wrapped in geo/filter fabric be placed

**Blue Sink MFL Pump Station & Pipeline
Hillsborough County, FL
MC² No. T111001.216**

on the approved subgrade to support the pump station foundation concrete. The No. 57 stone should be extended 3 feet beyond the perimeter of the foundation footprint. The gravel will provide a stable working platform, will help to preserve the subgrade and will be used to facilitate dewatering of the excavation.

Depending upon shallow groundwater levels and the effectiveness of dewatering at the time of construction, seepage may enter the excavated trenches from the bottom and sides. Such seepage will act to loosen soils and create difficult working conditions. Groundwater levels should be determined immediately prior to construction.

4.3.4 EXCAVATION CONSIDERATIONS

Excavation will be required to construct the pump station and pipelines associated with the project. The dewatering system should be in place and functioning prior to any excavation taking place. Piezometers installed prior to excavation should be used to verify that the dewatering system is performing adequately.

Based on the subsurface information collected, the existing soils being excavated at this site are anticipated to generally consist of very loose to medium dense fine sands (SP/SP-SM/SP-SC). We do not anticipate that the excavation of these materials will be a problem.

All structure excavations should be observed by the Geotechnical Engineer or his representative to explore the extent of any fill and excessively loose, soft, or otherwise undesirable materials. If the excavation appears suitable as load bearing materials, the soils should be prepared for construction by compaction to a dry density of at least 95% of the modified Proctor maximum dry density (ASTM D-1557) for a depth of at least 1 foot below the compacted No. 57 stone wrapped in geo/filter fabric, which will serve as a foundation base.

If soft pockets are encountered in the bottom of the structure excavations, the unsuitable materials should be removed and the proposed foundation elevation re-established by backfilling after the undesirable material has been removed. This backfilling may be done with a very lean concrete or with a well-compacted, suitable fill such as clean sand, gravel, or crushed #57 or #67 stone. Sand backfill should be compacted to a dry density of at least 95% of the modified Proctor maximum dry density (ASTM D-1557), as previously described. Gravel, or crushed #57 or #67 stone, if used, should be compacted and the compaction confirmed by visual observation.

It is possible that the proposed construction will consist of both open sloped excavation and the installation of bracing and/or sheet walls. Our scope of services did not include analysis of slope stability or sheet piling, however, for soils of the type present at the site we

recommend that all excavations be sloped no steeper than 3H:1V. Please refer to the Federal Temporary Excavation Regulations reported below.

4.3.5 FEDERAL TEMPORARY EXCAVATION REGULATIONS

In Federal Register Volume 54, No. 209 (October 1989), the United States Department of Labor, Occupational Safety and Health Administration (OSHA) amended its "Construction Standards for Excavations, 29 CFR, Part 1926, Subpart P." This document was issued to better insure the safety of workmen entering trenches or excavations. It is mandated by this federal regulation that all excavations, whether they be utility trenches, basement excavations, or footing excavations, be constructed in accordance with the revised OSHA guidelines. It is our understanding that these regulations are being strictly enforced and if they are not closely followed, the owner and the contractor could be liable for substantial penalties.

The contractor is solely responsible for designing and constructing stable, temporary excavations and should shore, slope, or bench the sides of the excavations as required to maintain stability of both the excavation sides and bottom. The contractor's responsible person, as defined in 29 CFR Part 1926, should evaluate the soil exposed in the excavations as part of the contractor's safety procedures. In no case should slope height, slope inclination, or excavation depth, including utility trench excavation depth, exceed those specified in these local, state, and federal safety regulations.

We are providing this information solely as a service to our client. **MC²** is not assuming responsibility for construction site safety or the contractor's activities; such responsibility is not being implied and should not be inferred.

4.3.6 UPLIFT RESISTANCE

Uplift resistance should be designed to resist the hydrostatic pressure and uplift of the anticipated maximum groundwater levels. Maximum groundwater levels should be the highest of the proposed seasonal high groundwater level or the 100 year flood level for this site. Uplift resistance can be created by both the dead weight of the structure as well as any backfill on any projecting parts of the base slab.

Uplift resistance from extension of the pump station slab should be calculated using a wedge from the outside upper edge of the base of the extended slab upward at a 30 degree angle to the ground surface. Below the water table, the backfills buoyant weight should be used. We estimate, based on other projects in this area, that the buoyant weight of the fine sands is approximately 48 pcf.

4.3.7 FOUNDATION RECOMMENDATIONS

The following design recommendations have been developed on the basis of the previously described project characteristics and subsurface conditions encountered. If there are any changes in the project characteristics, including project location on the site, a review must be made by **MC²** to determine if any modifications in the recommendations will be required. If the findings of such a review deem it necessary to modify the original recommendations, **MC²** should be retained for the submittal of a supplemental report.

Once final design plans and specifications are available, a general review by **MC²** is strongly recommended as a means to check that the evaluations made in preparation of this report are correct and that earthwork and foundation recommendations are properly interpreted and implemented.

a. Shallow Foundation for Electric Room

Based on the results of the test borings and our engineering evaluation and recommendations, it is our opinion that the proposed electric room may be supported on shallow foundations. Foundations or bottom slabs of below grade structures may bear on newly placed, properly compacted fill. After confirming the presence of clean sands (SP/SP-M/SP-SC) at the site during construction, it may be possible to utilize these existing materials for foundation support depending upon the type and quality of the fill material and the expected loads.

Boring CPT-1, performed in the proposed pump station and electrical room generally encountered the following soils.

Depth (ft)	Elev. (ft)	Classification by Robertson 1990	Equivalent SPT "N" Values	Density (Consistency)	Comment
0 – 16	35.8 – 19.8	Sand, Silty Sand to Sandy Silt and Silt	7 – 13	Loose to medium dense Sands, stiff to very stiff Silts	
16 – 21	19.8 – 14.8	Sands and Silty Sands	10 – 25	Medium dense	
21 – 28	14.8 – 7.8	Clayey Silt to Silty Clay	4 – 10	Soft to firm	
28 – 38	7.8 – (-2.2)	Sandy Silt to Clayey Silt	4 – 45	Very soft to hard	

**Blue Sink MFL Pump Station & Pipeline
Hillsborough County, FL
MC² No. T111001.216**

Depth (ft)	Elev. (ft)	Classification by Robertson 1990	Equivalent SPT "N" Values	Density (Consistency)	Comment
38 – 38.9	-2.2 to -3.1	Sand	45	Hard	Very dense Sand interpreted as hard Limestone at a depth of 38.0 feet

If encountered during construction, unsuitable materials such as clays, organic material and soils, debris, root and clay clods should be removed and replaced with properly compacted clean sands (SP/SP-SM/SP-SC). Based on our evaluation and analyses, the soils will then be capable of supporting the proposed structures on shallow foundations after proper subgrade preparation (including overexcavating and replacing the unsuitable materials and soils), including vibratory surface compaction (if nearby structures are farther than 50 feet) followed by the addition of compacted structural fill.

Based on the anticipated light construction, shallow foundations should be designed for a net maximum allowable bearing pressure not to exceed **2,500** pounds per square foot (psf). The foundation and floor slab should bear on properly placed and compacted cohesionless (sand) structural fill. The existing near surface sandy soils should be improved by heavy vibratory compaction after clearing operations to improve foundation support and reduce total and differential settlement.

All continuous wall (strip) footings should be embedded so that the bottom of the foundation is a minimum of 18 inches below adjacent compacted grades on all sides. Strip or wall footings should be a minimum of 24 inches wide. Individual column footings should be a minimum of 48 inches wide and embedded a minimum of 24 inches below adjacent compacted grades on all sides. The minimum footing sizes should be used regardless of whether or not the foundation loads and allowable bearing pressures dictate a smaller size. These minimum footing sizes tend to provide adequate bearing area to develop bearing capacity and account for minor variations in the bearing materials. All footings should be constructed in a "dry" fashion. All footing excavations should be covered during rain events. Uncovered excavations may become oversaturated and difficult to compact during rain events. Surface run-off water should be drained away from the excavations and not allowed to pond. Top and bottom reinforcement of the foundations should be utilized to minimize the effect of settlement on the foundations and to limit any

cracking of the concrete.

After proper subgrade preparation, including the removal of any unsuitable materials, soils and debris, replaced with clean compacted sand and with top and bottom steel reinforcement of the footings, we estimate maximum total and differential foundation settlements of less than 1 inch and ½ inch, respectively, across a distance of 25 feet.

Footing evaluations should be performed prior to reinforcement and concrete placement. If unsuitable bearing soils are encountered, these soils will need to be recompacted in place, removed and replaced with properly compacted fill, or foundations deepened, to achieve suitable bearing.

Foundation bearing surface evaluations should be performed and concrete placed as quickly as possible after the footings are excavated. Footing concrete should be poured the same day footing excavations are made. If it is required that foundation excavations be left open for more than one day, they should be protected by the placement of a thin (2-3 inch) mud mat of lean concrete. Soils left exposed will soften and will require additional excavation.

b. Floor Slab-on-Grade for Electric Room

The floor slab may be safely supported as a slab-on-grade provided any undesirable materials are removed and replaced with controlled structural fill. Based on correlation to published data and our analysis, the soils at the sites are expected to exhibit a modulus of subgrade reaction (k) of 150 pci, assuming the upper 8 inches of subgrade soils are uniformly compacted to at least 98 percent of the Modified Proctor maximum dry density.

The floor slab should be jointed in accordance with American Concrete Institute (ACI) specifications to reduce the potential for cracking resulting from any differential movement and shrinkage.

Detailed analysis was not performed concerning total and differential post-construction settlement of the floor slabs. Based on the above noted assumptions, the floor slab loads, and the proposed design, we anticipate a maximum total slab settlement on the order of 1 inch or less, with differential slab settlements on the order of ½ inch or less across a horizontal distance of 25 feet.

An impermeable vapor barrier (such as polyethylene sheeting) beneath the building slab is likely not needed at these sites due to the lower groundwater elevations in

relation to the anticipated final grade. However, the final decision as to the use of a vapor barrier is left to the owner and designer.

The soil subgrade in the area of concrete slab-on-grade support is often disturbed during foundation and superstructure construction. We recommend that floor slab subgrades be evaluated by a representative of **MC²** immediately prior to beginning floor slab construction. If low consistency soils are encountered which cannot be adequately densified in place, such soils should be removed and replaced with well-compacted fill material or with well-compacted crushed stone materials.

c. Mat Foundation Recommendations for New Pump Station

Based on the results of our test borings and after subgrade preparation and placement of any fill as discussed in this report, a mat foundation system can be used to support the proposed new pump station. The net allowable bearing pressure should not exceed 2,500 psf. The mat design may be conducted using a modulus of subgrade reaction (k_s) of 150 pounds per cubic inch for densified in-place soils or compacted structural fill. Minimum embedment depths for this type of foundation system should be 2.0 feet, which can be achieved with the use of a perimeter key extending below the mat. We suggest the placement of a minimum of 2 feet of stone such as FDOT No. 57 or FDOT No. 67 beneath the slab if conditions warrant (i.e., wet conditions) or unsuitable clayey or organic soils are encountered at the proposed foundation bearing depth. An impermeable vapor barrier may be utilized; however, the final decision to use a vapor barrier is left to the owner and designer.

Existing sandy soils may be reused after removing all organic matter to build up the grade if required. Alternatively, durable crushed stone may be used below the groundwater and would not require compaction. The soil subgrade in the area of concrete mat support is often disturbed during foundation construction. We recommend that the concrete slab subgrade be evaluated by a representative of **MC²** immediately prior to placing stone and beginning floor slab construction. If low consistency soils are encountered which cannot be adequately densified in place, such soils should be removed and replaced with well-compacted structural fill material.

For the purpose of estimating the settlement for the mat foundation, we used a total contact pressure of about 2500 psf. We also assumed, based on the soil conditions encountered in our borings, that most of the settlement will occur during load applications. Based on these assumptions, we anticipate that the

total settlement should not exceed one (1) inch and differential settlement should not exceed one half (1/2) inch.

4.3.8 EARTH SLOPE AND RETAINING WALL RECOMMENDATIONS

Formal analysis of slope stability was beyond the scope of work for this project. Based on the soil types encountered at the site, we recommend that temporary or permanent slopes not exceed 3(H) to 1(V) for this project. The crest or toe of slopes should be no closer than 10 feet to any structure foundation and no closer than 5 feet to the nearest edge of pavement.

Below grade walls such as the pump station walls and pipes must be designed to resist lateral earth pressures. The "at rest" earth pressure state should be used for soils supporting rigidly restrained walls such as those for the pump station structure. Assuming that the soils at the site consist of fine sands (SP/SP-SM/SP-SC), they would be suitable for use as backfill. The table below presents recommended values of earth pressure coefficients for the select backfill materials, assuming an approximate angle of internal friction of 30 degrees. Equivalent fluid densities are frequently used for the calculation of lateral earth pressures. Equivalent fluid densities for the "at-rest" and active conditions based upon a total unit weight of 115 pcf and a fluid unit weight of 62.4 pcf are shown below.

Earth Pressure State	Earth Pressure Coefficient	Equivalent Fluid Density (pcf)		
		Above Water Table	Below Water Table (No Hydrostatic Pressure)	Below Water Table (with Hydrostatic Pressure)
At-Rest (soil backfill)	0.5	57	27	88
Active	0.3	35	16	78
Passive	3.0	345	150	220

The design values and recommendations presented on the previous page assume that the backfill behind the wall will be horizontal with no surcharge loads. Equivalent fluid densities for *no hydrostatic pressure and including hydrostatic pressure are given above. Walls below the groundwater level should include hydrostatic pressures.*

4.3.9 ON SITE SOIL SUITABILITY AND STRUCTURAL FILL

Soil Types SP/SP-SM/SP-SC, which were encountered in the borings performed, can be categorized as relatively clean fine sands, slightly silty fine sands or slightly clayey

fine sand based on the Unified Soil Classification System (USCS). Typically, these materials are deemed suitable for reuse as fill. These soils can be used for grading purposes, site leveling, general engineered fill, structural fill and backfill against the structure wall as well as in other areas, provided the fill is free of organic materials, clays, debris or any other material deemed unsuitable for construction. These soil types will possess improved permeability or drainage characteristics as compared to the underlying soils with increased fines content. These fine sands should require minimal processing in order to properly place and compact. Moisture contents will probably require adjustment in order to affect maximum densification, depending upon specification requirements. It is anticipated that the majority of these soil types will be excavated below the water table and can occur in a relatively saturated state, but should effectively drain within stockpiles. Soils not meeting these requirements will need to be evaluated by **MC²** during construction.

If off-site sources of fill are needed, they should consist of fine sand (SP/SP-SM/SP-SC) with less than 12% passing the No. 200 sieve, free of rubble, organics, clays, debris and other unsuitable material. The moisture content of fill soils at the time of placement and compaction should generally be within 2 percentage points of their optimum moisture content. All materials to be used for backfill or compacted fill construction should be evaluated and, if necessary, tested by **MC²** prior to placement to determine if they are suitable for the intended use. In general, based on the boring results, the majority of the on-site sandy materials excavated for the drainage improvements are suitable for use as structural fill and as general subgrade fill and backfill.

The fill material placed around the pump stations structures is critical to support any upper piping. Proper compaction and control of the fill being placed will be required from the bottom of the excavation to the surface in order to properly support utility or other structures.

Fill material placed adjacent to the walls and beneath structures and piping should be placed in 6 to 8 inch loose lifts compacted using a static roller if near existing structures. Within small excavations such as in utility trenches, around manholes, or within 5 feet of any of the structure walls, we recommend the use of smaller, hand or remote-guided equipment. Placement of loose lift thickness of 4 inches is recommended when using such equipment. All structural fill should be compacted to a dry density of at least 98 percent of the modified Proctor maximum dry density (ASTM D-1557). A representative of **MC²** should perform field density tests on each lift as necessary to assure that adequate compaction is achieved.

5.0 CONSTRUCTION CONSIDERATIONS

5.1 GENERAL

It is recommended that **MC²** be retained to provide observation and testing of construction activities involved in the foundation, earthwork, and related activities of this project to ensure that the recommendations contained herein are properly interpreted and implemented. If **MC²** is not retained to perform these functions, we cannot be responsible for the impact of those conditions on the performance of the project.

5.2 FILL PLACEMENT AND SUBGRADE PREPARATION

The following are our general recommendations for overall site preparation and mechanical densification work for the proposed project based on the anticipated construction and our boring results. These recommendations should be used as a guideline for the project general specifications by the Design Engineer.

1. The excavated subgrade (dewatered trench bottom) for the pipes and associated structures should be leveled, cut to grade if necessary, and then compacted with a vibratory compactor (if located farther than 50 feet from nearby structures). Careful observations should be made during compaction to help identify any areas of soft yielding soils that may require overexcavation and replacement. If unsuitable material, such as organic or clayey soils, is encountered at the bottom of the pipe or structure embedment depth, overexcavation of an additional 2 and 3 feet of the material is recommended for the pipe and structure, respectively. The excavation should then be backfilled to foundation grade with clean sands in controlled lifts not exceeding 6-inches and compacted to a density of at least 98 percent of the maximum density as determined by ASTM D-1557. Care should be used when operating the compactor to avoid transmission of vibrations to existing structures or other construction operations that could cause settlement damage or disturb occupants. Dewatering may also have an effect on adjacent structures. A preconstruction survey with video and/or photographs of adjacent residences/structures is recommended to check for existing cracking prior to construction and during construction. Vibration and groundwater levels monitoring are also recommended.
2. Prior to beginning compaction, soil moisture contents may need to be

controlled in order to facilitate proper compaction. A moisture content within 2 percentage points of the optimum indicated by the modified Proctor test (ASTM D-1557) is recommended.

3. Following satisfactory completion of the initial compaction on the excavation bottom, the construction areas may be brought up to finished subgrade levels. Fill should consist of fine sand with less than 12% passing the No. 200 sieve, free of rubble, organics, clay, debris and other unsuitable material. Fill should be tested and approved prior to acquisition and/or placement. Approved sand fill should be placed in loose lifts not exceeding 6-inches in thickness and should be compacted to a minimum of 98% of the maximum modified Proctor dry density (ASTM D-1557). Density tests to confirm compaction should be performed in each fill lift before the next lift is placed.
4. It is recommended that a representative from our firm be retained to provide on-site observation of earthwork activities. The field technician would monitor the placement of approved fills and compaction and provide compaction testing. Density tests should be performed in subgrade sands after rolling and in each fill lift. It is important that **MC²** be retained to observe that the subsurface conditions are as we have discussed herein, and that construction and fill placement is in accordance with our recommendations.

6.0 REPORT LIMITATIONS

The recommendations detailed herein are based on the available soil information obtained by **MC²** and information provided by **MWH** for the proposed project. If there are any revisions to the plans for this project or if deviations from the subsurface conditions noted in this report are encountered during construction, **MC²** should be notified immediately to determine if changes in the foundations or other recommendations are required. In the event that **MC²** is not retained to perform these functions, **MC²** can't be responsible for the impact of those conditions on the performance of the project.

The geotechnical engineer warrants that the findings, recommendations, specifications, or professional advice contained herein have been made in accordance with generally accepted professional geotechnical engineering practices in the local area. No other warranties are implied or expressed.

After the plans and specifications are more complete, the geotechnical engineer should be

**Blue Sink MFL Pump Station & Pipeline
Hillsborough County, FL
MC² No. T111001.216**

provided the opportunity to review the final design plans and specifications to assess that our engineering recommendations have been properly incorporated into the design documents. At that time, it may be necessary to submit supplementary recommendations. This report has been prepared for the exclusive use of **MWH**.

APPENDIX A

Table 2 – Summary of Boring Locations, Groundwater Table and SHWT

Table 3 – Summary of Laboratory Test Results

Boring Location Plan – Sheet 1

Report of Core Borings – Sheet 2

Cone Penetration Test (CPT) Results for boring CPT-1 – Sheet 3

Cone Penetration Testing Description and Summary

Table 2
Summary of Boring Locations, Groundwater Table and SHWT
Blue Sink MFL Pump Station and Pipeline
Hillsborough County, FL
MC² Project No. T111001.216

Boring No.	B/L No. 1, Station/Offset (ft) (City Raw Water Main Project)	B/L No. 2, Station/Offset (ft) (Blue Sink Project)	Boring Depth (ft)	Existing Water Table Depth (ft)	Approx. Boring Elev. (ft)	Approx. Water Table Elev. (ft)	Approx. Est. Seasonal High GWT Depth/elev. (ft)/
Proposed Pump Station							
CPT-1	-	15+10/ 5 LT	38.9	-	35.8	-	Depth/Elevation likely controlled by the GW level in Blue Sink
Proposed Pipeline							
AB-1	-	14+75/ 18 LT	7.0	GNE	33.5	<26.5	
AB-2	-	14+50/ 18 LT	7.0	GNE	32.0	<25.0	
AB-3	-	12+75/ 13 LT	7.0	GNE	30.0	<23.0	Depth/Elevation likely controlled by the GW level in Blue Sink
AB-4	-	12+45,/13 LT	7.0	GNE	32.0	<25.0	
AB-5	-	12+00/ 13 LT	7.0	GME	30.0	<23.0	Perched above a depth of 2.5 feet where SC soils were encountered
B-1	1+00/ 0'	-	20.0	3.0	25.5	22.5	Perched at surface due to SC (> 0.0 and > 25.5)
B-2	9+00/ 0'	-	25.0	4.0	26.0	22.0	2.0/20.0

Table 2
Summary of Boring Locations, Groundwater Table and SHWT
Blue Sink MFL Pump Station and Pipeline
Hillsborough County, FL
MC² Project No. T111001.216

Boring No.	B/L No. 1, Station/Offset (ft) (City Raw Water Main Project)	B/L No. 2, Station/Offset (ft) (Blue Sink Project)	Boring Depth (ft)	Existing Water Table Depth (ft)	Approx. Boring Elev. (ft)	Approx. Water Table Elev. (ft)	Approx. Est. Seasonal High GWT Depth/elev. (ft)/
B-3	20+50/ 0'	-	20.0	4.0	24.0	20.0	Perched at surface due to SC (> 0.0 and > 25.5)
Notes:							
1.	B/L = Baseline along the pipe or for the Blue Sink project						
2.	GNE = Groundwater table not encountered within the depth explored.						
3.	Boring elevations and stations obtained from preliminary survey provided by MWH and Greeley and Hansen.						

Table 3
Summary of Laboratory Testing
Blue Sink MFL Pump Station and Pipeline
Hillsborough County, F004C
MC² Project No. T111001.216

Boring No.	B/L No. 1, Station/Offset (ft) (City Raw Water Main Project)	B/L No. 2, Station/Offset (ft) (Blue Sink Project)	Sample Depth (Feet)	Organic Content (%)	Natural Moisture Content (%)	Sieve Analysis (% Passing)					Atterberg Limits		Unified Soil Classification
						#10	#40	#60	#100	#200	LL (%)	PI (%)	
Blue Sink MFL Pump Station and Pipeline													
B-1	1+00/ 0'		0.0 -2.0		21					28			SC
B-1	1+00/ 0'		8.0 – 12.0		107					46			SC
B-3	20+50/ 0'		4.0 – 6.0		24					27			SC
B-3	20+50/ 0'		6.0 – 8.0		34					47			SC
AB-5		12+00/ 13 LT	2.5 – 4.0		16					31			SC

FIGURE 1-1

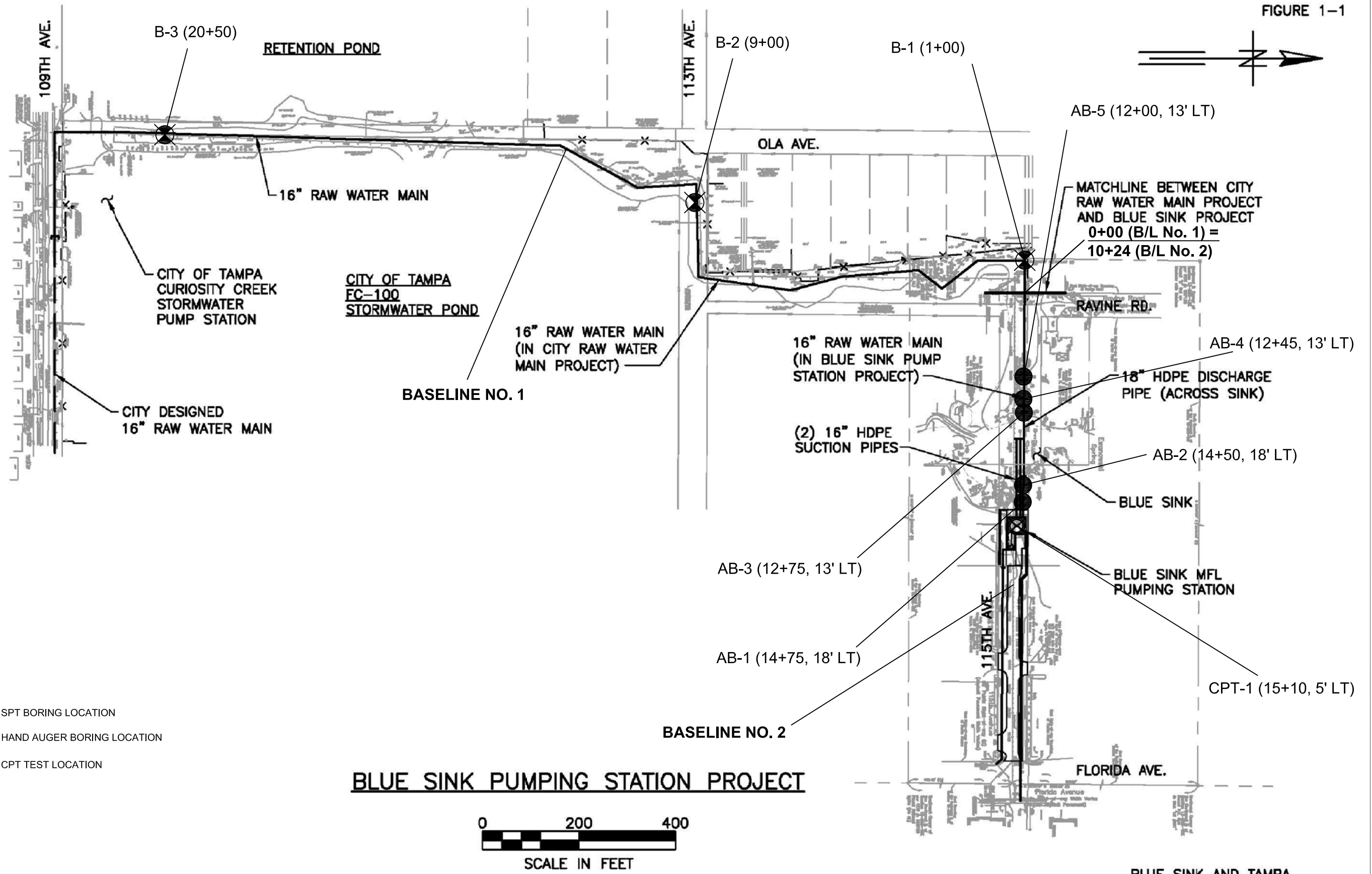

LEGEND

- APPROXIMATE SPT BORING LOCATION
- APPROXIMATE HAND AUGER BORING LOCATION
- APPROXIMATE CPT TEST LOCATION

BLUE SINK PUMPING STATION PROJECT

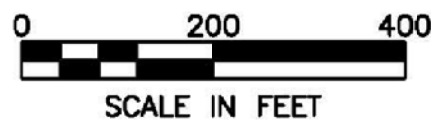

BLUE SINK AND TAMPA

DATE	NAME	REVISION	APPROVED BY:	NAME DATE		BORING LOCATION PLAN	PROJECT NO.	SHEET NO.
				DESIGNED BY:	IR 02/13	BLUE SINK MFL PUMP STATION & PIPELINE HILLSBOROUGH COUNTY, FLORIDA	T111001.216	1
				DRAWN BY:	IR 02/13			
				CHECKED BY:	KS 02/13			
				SUPERVISED BY:				



MC SQUARED, INC.
Geotechnical Consultants
 5808 Breckenridge Parkway, Suite-A
 Tampa, Florida 33610
 Ph: 813-623-3399 Fax: 813-623-6636

FLORIDA ENGINEERING CERTIFICATE
 OF AUTHORIZATION No. 9191
 Kermit Schmidt, P.E.
 FLORIDA LICENSE No. 45603

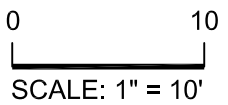
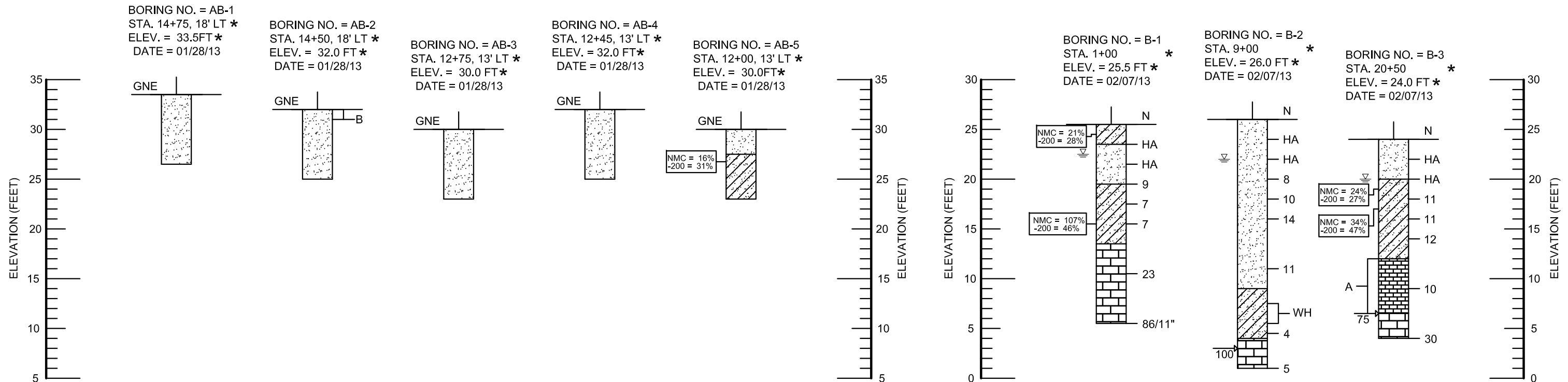

LEGEND

- (SP/SP-SM/SP-SC) BROWN OR GRAY FINE SAND, SLIGHTLY SILTY FINE SAND, TO SLIGHTLY CLAYEY FINE SAND.
- (LS) PALE BROWN, WHITE, OR GRAY HIGHLY WEATHERED LIMESTONE.
- (SC) GRAY CLAYEY FINE SAND.
- (CL) BROWN OR GRAY CALCAREOUS CLAY WITH LIMESTONE FRAGMENTS

- A WITH TRACES TO SOME LIMESTONE FRAGMENTS
- B WITH SOME SHELL AND ROCK FRAGMENTS

* ELEVATIONS, STATIONS, AND OFFSETS WERE OBTAINED FROM PLANS PROVIDED BY MWH AND GREELEY & HANSEN AND ARE APPROXIMATE.

- NOTES:**
- WATER TABLE
 - HA HAND AUGER
 - GNE GROUNDWATER NOT ENCOUNTERED
 - WH WEIGHT OF HAMMER

- N SPT N-VALUE
- LOSS OF CIRCULATION (%)
- NMC NATURAL MOISTURE CONTENT (%)
- 200 FINES PASSING A NO. 200 SIEVE (%)

GRANULAR MATERIALS- RELATIVE DENSITY	SPT (BLOWS/FT)
VERY LOOSE	LESS THAN 4
LOOSE	5-10
MEDIUM	11-30
DENSE	31-50
VERY DENSE	GREATER THAN 50
SILTS AND CLAYS CONSISTENCY	SPT (BLOWS/FT)
VERY SOFT	LESS THAN 2
SOFT	3-4
FIRM	5-8
STIFF	9-15
VERY STIFF	16-30
HARD	30-50
VERY HARD	GREATER THAN 50

DATE	NAME	REVISION	APPROVED BY:	DESIGNED BY:	NAME	DATE	REPORT OF CORE BORINGS	PROJECT NO.	SHEET NO.
				IR	IR	02/13	BLUE SINK MFL PUMP STATION & PIPELINE HILLSBOROUGH COUNTY, FLORIDA	T111001.216	2
				KS	KS	02/13			

MC SQUARED, INC.
Geotechnical Consultants
5808 Breckenridge Parkway, Suite-A
Tampa, Florida 33610
Ph: 813-623-3399 Fax: 813-623-6636

FLORIDA ENGINEERING CERTIFICATE OF AUTHORIZATION No. 9191
Kermit Schmidt, P.E.
FLORIDA LICENSE No. 45603

Depth Plots

Scale Grid Depth Units Change Header Load Header Print Save Scale Use Saved Scale Start Depth/Elevation Define Layers Return

ARA Vertek

Operator: John MC Squared
 Sounding: PSCPT-1
 Cone Used: DSA1102

CPT Date/Time: 2/1/2013 9:12:42 AM
 Location: East of MOB
 Job Number: 1744

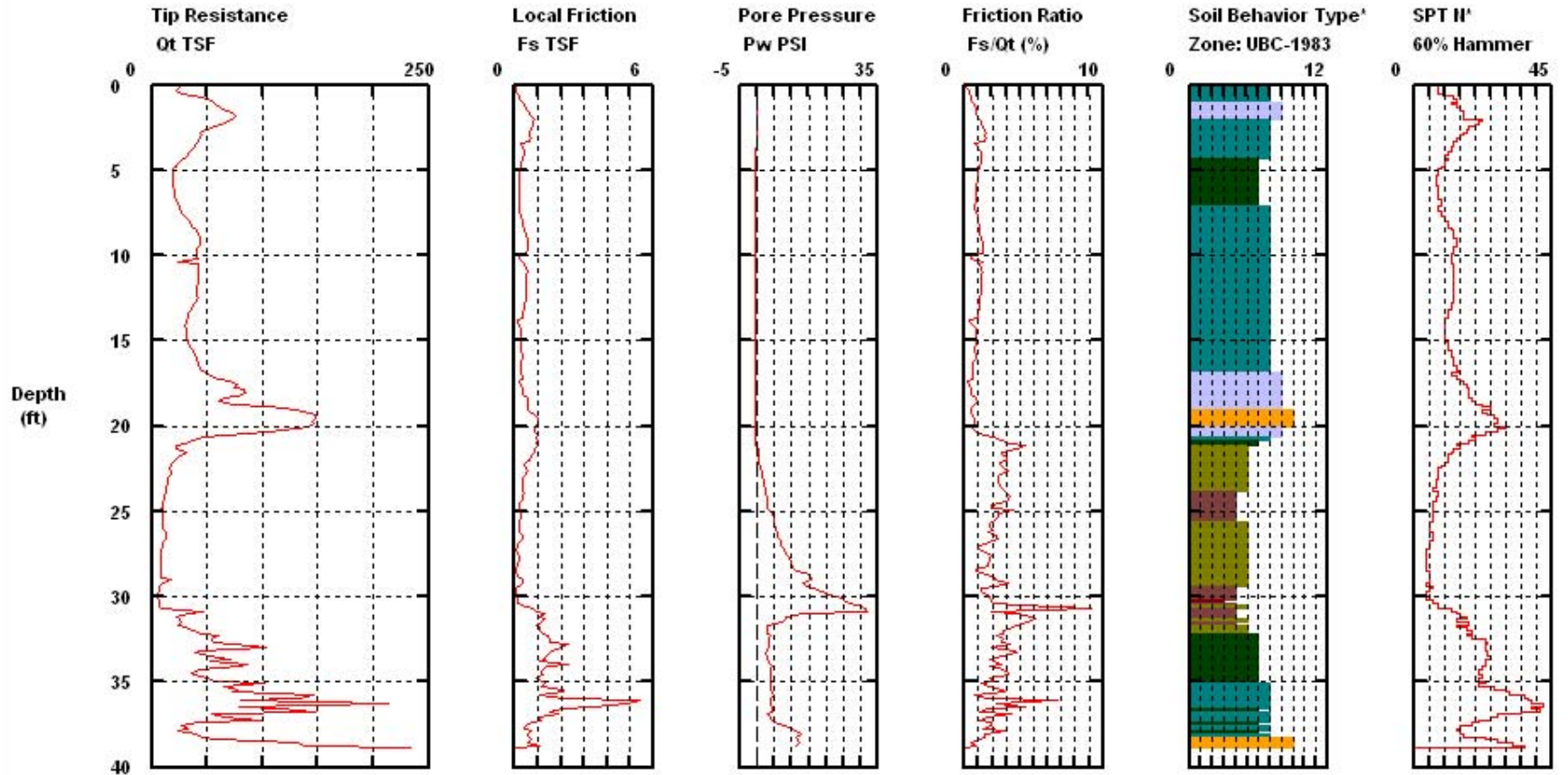

Maximum Depth = 38.88 feet

Depth Increment = 0.16 feet

- | | | | |
|--------------------------|-----------------------------|----------------------------|--------------------------------|
| 1 sensitive fine grained | 4 silty clay to clay | 7 silty sand to sandy silt | 10 gravelly sand to sand |
| 2 organic material | 5 clayey silt to silty clay | 8 sand to silty sand | 11 very stiff fine grained (*) |
| 3 clay | 6 sandy silt to clayey silt | 9 sand | 12 sand to clayey sand (*) |

CONE PENETRATION TESTING DESCRIPTION AND SUMMARY

Cone penetration testing is a geotechnical technique designed to evaluate subsurface conditions and geotechnical soil properties. Cone penetrometer tests are a quasistatic penetration test, meaning that the cone is pushed at a slow rate rather than driven with a hammer or rotary drilling. During a cone penetration test (CPT), a cylindrical metal cone is advanced below land surface at a constant and slow rate, normally by a hydraulic press. As the cone is advanced, measurements are made and data is recorded that indicate the various soil properties encountered by the cone. Cone penetration testing is a cost effective and rapid test method when compared to other subsurface testing procedures.

The CPT is designed to evaluate subsurface conditions based primarily on the resistance to penetration encountered by the cone tip. Resistance measurements are also recorded for the cone sleeve, or shaft. In the case of piezocones, subsurface pore pressure can also be measured to assist the evaluation of soil types. The CPT can be performed by continuously advancing the cone without withdrawing it from the borehole. This makes a CPT very time-effective when compared to other testing procedures such as Standard Penetration Test (SPT) where the penetrometer must be withdrawn from the borehole at each test interval.

CPT can be performed using a variety of different cones. However, cone penetrometers with 60 degree apex angle and a 1.4 inch diameter have generally become the standard tip design. This translates to a cone base area of 1.54 squared inches. The rate of tip advancement is also important, and an advancement rate of 0.79 inches (2 centimeters) per second has also become standard.

The SPT method has been standardized by the American Society for Testing and Materials (ASTM) under standard designation D 5778. ASTM D 5778 sets forth standard procedures for determining cone resistance from electronic friction-cone penetrometers and pore pressure using piezocone penetrometers.

Standard data collected during a CPT is the cone resistance and friction sleeve resistance. The cone resistance, or end bearing resistance, is measure by the force required to advance the cone, and is equal to the vertical force applied divided by the cone base area. The friction sleeve resistance, or local side friction, measures the amount of friction on the cone sleeve, and is equal to the shear force applied to the sleeve divided by the sleeve surface area.

The CPT data discussed above is commonly used to calculate the corrected total cone resistance, pore water pressure ratio, and friction ratio. The corrected total cone resistance is the tip resistance corrected for pore pressure acting behind the tip, and allows an estimated of the total resistance to be made. The pore water pressure ratio is expressed as a percentage, and represents the ratio of excess pore pressure to cone

resistance. The friction ratio is the ratio of sleeve resistance to tip resistance measured at a point where the middle of the sleeve and the tip are equal depths.

The CPT provides data that can be used to estimate various subsurface properties including soil type and strength. Piezocone penetrometer tests are highly effective for identifying sand, silt, and clay layers, as well as determining pore pressure. These tests are also moderately effective for determining other geotechnical engineering properties including friction angle, undrained shear strength, density index, constrained modulus, coefficient of consolidation, permeability, horizontal stress, and over consolidation ratios.

Modern CPTs are performed using cones with electronic circuitry embedded directly in the tips to record subsurface measurements. These measurements can be transmitted directly to the operator for instant computer storage of the data, or stored within the tip for data retrieval at the end of the CPT. By either method, the data collected during the CPT can be recorded on a computer and available for analysis directly following the CPT.

Available software is used to evaluate the CPT data. Most of the data interpretations are based upon work produced by P.K. Robertson. While it is beyond the scope of this summary to discuss each evaluation performed by the software, descriptions of any reported data are available upon request.

APPENDIX B

Ground Penetrating Radar Report

Test Procedures

FINAL REPORT
GROUND PENETRATING RADAR
BLUE SINK PUMP STATION SITE
TAMPA, FL

Prepared for MC Squared, Inc.
Tampa, FL

Prepared by GeoView, Inc.
St. Petersburg, FL



February 6, 2013

Mr. Joe DiStefano, P.E.
MC Squared, Inc.
5808 A Breckenridge Parkway
Tampa, FL 33610

**Subject: Transmittal of Final Report for Ground Penetrating Radar
Blue Sink Pump Station Site – Tampa, FL
GeoView Project Number 18644**

Dear Mr. DiStefano,

GeoView, Inc. (GeoView) is pleased to submit the final report that summarizes and presents the results of the geophysical investigation conducted at the Blue Sink Pump Station Site in Tampa, FL. Ground penetrating radar, a geophysical technique, was used to evaluate near-surface geological conditions at the site. GeoView appreciates the opportunity to have assisted you on this project. If you have any questions or comments about the report, please contact us.

GEOVIEW, INC.

Michael J. Wightman, P.G.
President
Florida Professional Geologist
Number 1423

Stephen Scruggs, P.G.
Senior Geophysicist
Florida Professional Geologist
Number 2470

A Geophysical Services Company

*4610 Central Avenue
St. Petersburg, FL 33711*

*Tel.: (727) 209-2334
Fax: (727) 328-2477*

1.0 Introduction

A ground penetrating radar (GPR) survey was conducted on January 28, 2013 at the Blue Sink Pump Station site in Tampa, FL. The purpose of the GPR survey was to identify possible sinkhole-related features and, if possible, to identify top of the limestone stratum across the project site. A discussion of the field methods used to generate the report figures is provided in Appendix A2.1

2.0 Description of Geophysical Investigation

2.1 Ground Penetrating Radar Survey

The GPR survey was conducted along a series of perpendicular transects spaced about 10 feet (ft) apart (Figure 1). The GPR data was collected with a Mala radar system using both a 250 and 500-megahertz (MHz) antenna with time range settings of 186 and 76 nano-seconds, respectively. These time range settings provided information to an estimated depth of 20 to 25 ft below land surface (bls) for the 250 MHz GPR data and approximately 4 to 8 ft bls for the 500 MHz GPR data. The locations of the GPR lines are shown on Figure 1. A description of the GPR technique and the methods employed for geological characterization is provided in Appendix 2.

2.2 Hand Auger Boring

Several hand auger borings were performed at the project site by MC Squared personnel. Results from the hand auger borings indicated the presence of a surficial sand stratum to a depth of 7 ft bls.

3.0 Identification of Possible Geological Features Using GPR

The features observed on GPR data that are most commonly with a disruption of near-surface sediments associated with the presence of voids at depth are:

- A downwarping of GPR reflector sets, that are associated with suspected lithological contacts, toward a common center. Such features typically have with a bowl or funnel shaped configuration and can be associated with a deflection of overlying sediment horizons caused by the migration of sediments into voids in the underlying limestone. If the GPR reflector sets are sharply downwarping and intersect, they can create “bow-tie” shaped GPR reflection feature, which often designates the apparent center of the GPR anomaly.

- A localized significant increase in the depth of the penetration and/or amplitude of the GPR signal response. The increase in GPR signal penetration depth or amplitude is often associated with either a localized increase in sand content at depth or decrease in soil density.
- An apparent discontinuity in GPR reflector sets, that are associated with suspected lithological contacts. The apparent discontinuities and/or disruption of the GPR reflector sets may be associated with the downward migration sediments.

The greater the severity of these features or a combination of these features the greater the likelihood that the identified feature is related to a downward migration and disruption . It is not possible based on the GPR data alone to determine if an identified feature is a sinkhole or, more important, whether that feature is an active sinkhole.

4.0 Survey Results

The GPR data indicated the presence of a marginally-defined reflector at a depth range of 7 to 11 ft bls across the majority of the surveyed area. The GPR reflector set is below the depth of the hand auger borings and accordingly cannot be correlated to any lithological contact.

In regards to potential sinkhole activity, no observed areas of significant downwarping or other indicators of possible disturbed soils were observed within the effective penetration depth of the GPR signal. Accordingly, based on the results of the GPR survey sinkhole activity is not occurring at the project site.

It is suspected that the GPR reflector identified at 7 to 11 ft bls is not associated with top of limestone. However, it is expected that limestone is most likely present within 20 to 25 ft bls based on the regional geological setting, The inability of the GPR method to identify the top of the limestone stratum is common in this area of Tampa. This is because the limestone contact is often masked by a gradual increase in the clay content in the soils overlying the limestone. If this transition is gradual and the limestone somewhat weathered, a clear resolvable lithological contrast for the GPR is not available, resulting in the GPR not being able to identify the top of the limestone stratum. A discussion of the limitations of GPR in geological characterization studies is provided in Appendix 2.

APPENDIX 1
FIGURE

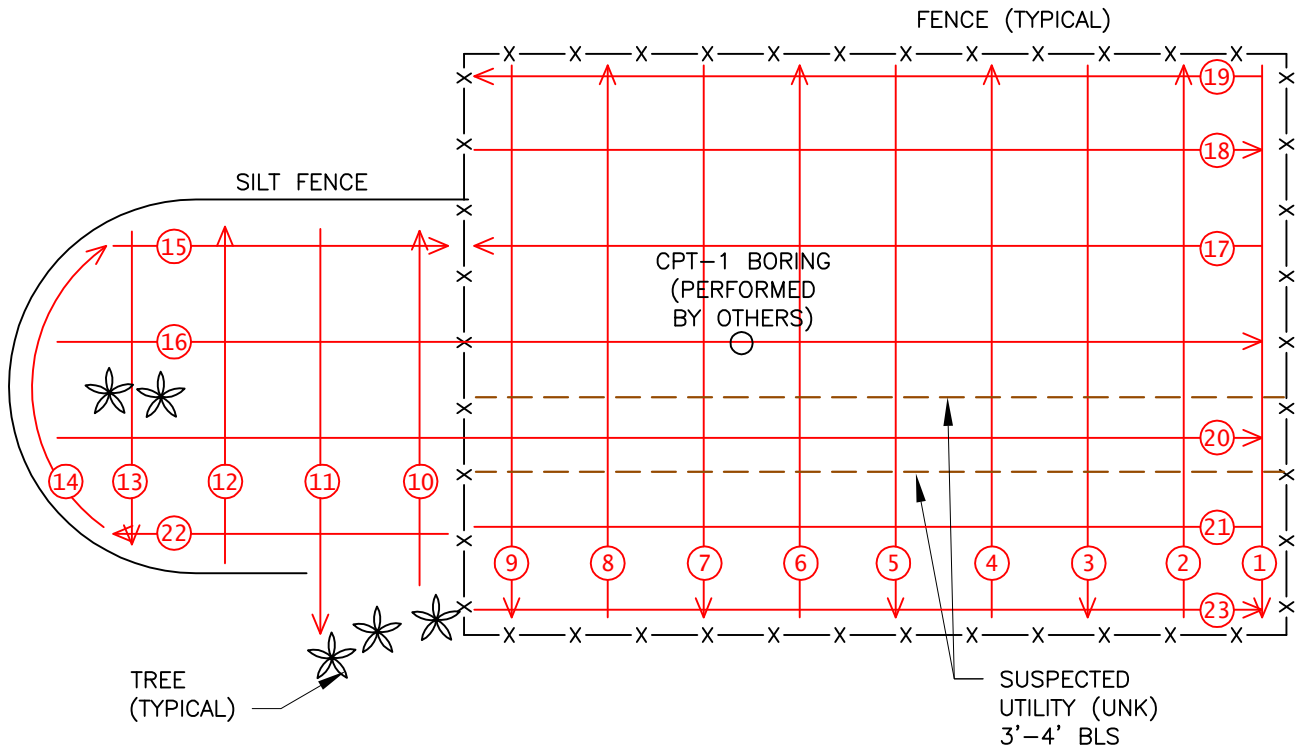

EXPLANATION

- PATH OF GPR TRANSECT LINES WITH DESIGNATION NUMBER
- HA LOCATION OF HAND AUGER BORING

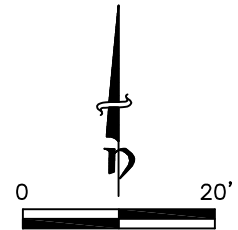

SCALE: 1"=20' APPROXIMATE



**FIGURE 1
SITE MAP
SHOWING RESULTS
OF GEOPHYSICAL
INVESTIGATION**

**BLUE SINK PUMP STATION
115TH STREET
TAMPA, FLORIDA**

MC2 INC.
TAMPA, FLORIDA

PROJECT:
18644
DATE:
02/06/13

APPENDIX 2

DESCRIPTION OF GEOPHYSICAL METHODS, SURVEY METHODOLOGIES AND LIMITATIONS

Ground Penetrating Radar (GPR) consists of a set of integrated electronic components that transmits high frequency (250 to 1500 megahertz [MHz]) electromagnetic waves into the ground and records the energy reflected back to the ground surface. The GPR system consists of an antenna, which serves as both a transmitter and receiver, and a profiling recorder that both processes the incoming signal and provides a graphic display of the data. The GPR data can be reviewed as both printed hard copy output or recorded on the profiling recorder's hard drive for later review. GeoView uses a Mala GPR system. Geological characterization studies are typically conducted using a 250 MHz antenna. A 500 MHz antenna is sometimes used if near-surface soil conditions are of a particular concern.

A GPR survey provides a graphic cross-sectional view of subsurface conditions. This cross-sectional view is created from the reflections of repetitive short-duration electromagnetic (EM) waves that are generated as the antenna is pulled across the ground surface. The reflections occur at the subsurface contacts between materials with differing electrical properties. The electrical property contrast that causes the reflections is the dielectric permittivity that is directly related to conductivity of a material. The GPR method is commonly used to identify such targets as underground utilities, underground storage tanks or drums, buried debris, voids or geological features.

The greater the electrical contrast between the surrounding earth materials and target of interest, the greater the amplitude of the reflected return signal. Unless the buried object is metal, only part of the signal energy will be reflected back to the antenna with the remaining portion of the signal continuing to propagate downward to be reflected by deeper features. If there is little or no electrical contrast between the target interest and surrounding earth materials it will be very difficult if not impossible to identify the object using GPR.

The depth of penetration of the GPR signal is very site specific and is controlled by two primary factors: subsurface soil conditions and selected antenna frequency. The GPR signal is attenuated (absorbed) as it passes through earth materials. As the energy of the GPR signal is diminished due to attenuation, the energy of the reflected waves is reduced, eventually to the level that the reflections can no longer be detected. As the conductivity of the earth materials increases, the GPR signal attenuation increases, hence a reduction in signal penetration depth. In

Florida, the typical soil conditions that severely limit GPR signal penetration are near-surface clays and/or organic materials.

The depth of penetration of the GPR signal is also reduced as the antenna frequency is increased. However, as antenna frequency is increased the resolution of the GPR data is improved. Therefore, when designing a GPR survey a tradeoff is made between the required depth of penetration and desired resolution of the data. As a rule, the highest frequency antenna that will still provide the desired maximum depth of penetration should be used. For areas outside of structures, a low-frequency (250 MHz) antenna is commonly used. This allows for maximum signal penetration and thereby maximum depth from which information will be obtained. A medium range frequency (500 MHz) antenna is sometimes also used to provided a higher resolution of near-surface (typically within 5 to 10 ft) conditions.

A GPR survey is conducted along survey lines (transects) that are measured paths along which the GPR antenna is moved. Electronic marks are placed in the data by the operator at designated points along the GPR transects. These marks allow for a correlation between the GPR data and the position of the GPR antenna on the ground.

For geological characterization surveys, the GPR survey is conducted along a set of perpendicularly orientated transects. The survey is conducted in two directions because subsurface features such as ravel zones are often asymmetric. Spacing between transects typically ranges from 10 to 50 feet. Closely spaced grids are used when the objective of the GPR survey is to identify all ravel zones within a project site. Coarser grids are used when the objective is to provide a general overview of site conditions. After completion of a survey using a given grid spacing, additional more-closely spaced GPR transects are often performed to better characterize ravel zone features identified by the initial survey. This information can be used to provide recommended locations for geotechnical borings.

Depth estimates to the top of lithological contacts are determined by dividing the time of travel of the GPR signal from the ground surface to the top of the feature by the velocity of the GPR signal. The velocity of the GPR signal is usually obtained from published tables of velocities for the type and condition (saturated vs. unsaturated) of soils underlying the site. The accuracy of GPR-derived depths typically ranges from 20 to 40 percent of the total depth.

Interpretation and Limitations of GPR data

The analysis and collection of GPR data is both a technical and interpretative skill. The technical aspects of the work are learned from both training and experience. Having the opportunity to compare GPR data collected in numerous settings to the results from geotechnical studies performed at the same locations develops interpretative skills for geological characterization studies.

The ability of GPR to collect interpretable information at a project site is limited by the attenuation (absorption) of the GPR signal by underlying soils. Once the GPR signal has been attenuated at a particular depth, information regarding deeper geological conditions will not be obtained. GPR data can only resolve subsurface features that have a sufficient electrical contrast between the feature in question and surrounding earth materials. If an insufficient contrast is present, the subsurface feature will not be identified.

GeoView can make no warranties or representations of geological conditions that may be present beyond the depth of investigation or resolving capability of the GPR equipment or in areas that were not accessible to the geophysical investigation.

TEST PROCEDURES

The general field procedures employed by MC Squared, Inc. (**MC²**) are summarized in the American Society for Testing and Materials (ASTM) Standard D420 which is entitled "Investigating and Sampling Soil and Rock". This recommended practice lists recognized methods for determining soil and rock distribution and groundwater conditions. These methods include geophysical and in-situ methods as well as borings.

Standard Drilling Techniques

To obtain subsurface samples, borings are drilled using one of several alternate techniques depending upon the subsurface conditions. Some of these techniques are:

In Soils:

- a) Continuous hollow stem augers.
- b) Rotary borings using roller cone bits or drag bits, and water or drilling mud to flush the hole.
- c) "Hand" augers.

In Rock:

- a) Core drilling with diamond-faced, double or triple tube core barrels.
- b) Core boring with roller cone bits.

The drilling method used during this exploration is presented in the following paragraph.

Hollow Stem Augering: A hollow stem augers consists of a hollow steel tube with a continuous exterior spiral flange termed a flight. The auger is turned into the ground, returning the cuttings along the flights. The hollow center permits a variety of sampling and testing tools to be used without removing the auger.

Core Drilling: Soil drilling methods are not normally capable of penetrating through hard cemented soil, weathered rock, coarse gravel or boulders, thin rock seams, or the upper surface of sound, continuous rock. Material which cannot be penetrated by auger or rotary soil-drilling methods at a reasonable rate is designated as "refusal material". Core drilling procedures are required to penetrate and sample refusal materials.

Prior to coring, casing may be set in the drilled hole through the overburden soils, to keep the hole from caving and to prevent excessive water loss. The refusal materials are then cored according to ASTM D-2113 using a diamond-studded bit fastened to the end of a hollow, double or triple tube core barrel. This device is rotated at high speeds, and the cuttings are brought to the surface by circulating water. Core samples of the material penetrated are protected and retained in the swivel-mounted inner tube. Upon completion of each drill run, the core barrel is brought to the surface, the core recovery is measured, and the core is placed, in sequence, in boxes for storage and transported to our laboratory.

Sampling and Testing in Boreholes

Several techniques are used to obtain samples and data in soils in the field; however the most common methods in this area are:

- a) Standard Penetration Testing
- b) Undisturbed Sampling
- c) Dynamic Cone Penetrometer Testing
- d) Water Level Readings

The procedures utilized for this project are presented below.

Standard Penetration Testing: At regular intervals, the drilling tools are removed and soil samples obtained with a standard 2 inch diameter split tube sampler connected to an A or N-size rod. The sampler is first seated 6 inches to penetrate any loose cuttings, and then driven an additional 12 inches with blows of a 140 pound safety hammer falling 30 inches. Generally, the number of hammer blows required to drive the sampler the final 12 inches is designated the "penetration resistance" or "N" value, in blows per foot (bpf). The split barrel sampler is designed to retain the soil penetrated, so that it may be returned to the surface for observation. Representative portions of the soil samples obtained from each split barrel sample are placed in jars, sealed and transported to our laboratory.

The standard penetration test, when properly evaluated, provides an indication of the soil strength and compressibility. The tests are conducted according to ASTM Standard D1586. The depths and N-values of standard penetration tests are shown on the Boring Logs. Split barrel samples are suitable for visual observation and classification tests but are not sufficiently intact for quantitative laboratory testing.

Water Level Readings: Water level readings are normally taken in the borings and are recorded on the Boring Records. In sandy soils, these readings indicate the approximate location of the hydrostatic water level at the time of our field exploration. In clayey soils, the rate of water seepage into the borings is low and it is generally not possible to establish the location of the hydrostatic water level through short-term water level readings. Also, fluctuation in the water level should be expected with variations in precipitation, surface run-off, evaporation, and other factors. For long-term monitoring of water levels, it is necessary to install piezometers.

The water levels reported on the Boring Logs are determined by field crews immediately after the drilling tools are removed, and several hours after the borings are completed, if possible. The time lag is intended to permit stabilization of the groundwater level that may have been disrupted by the drilling operation.

Occasionally the borings will cave-in, preventing water level readings from being obtained or trapping drilling water above the cave-in zone.

BORING LOGS

The subsurface conditions encountered during drilling are reported on a field boring log prepared by the Driller. The log contains information concerning the boring method, samples attempted and recovered, indications of the presence of coarse gravel, cobbles, etc., and observations of groundwater. It also contains the driller's interpretation of the soil conditions between samples. Therefore, these boring records contain both factual and interpretive information. The field boring records are kept on file in our office.

After the drilling is completed a geotechnical professional classifies the soil samples and prepares the final Boring Logs, which are the basis for our evaluations and recommendations.

SOIL CLASSIFICATION

Soil classifications provide a general guide to the engineering properties of various soil types and enable the engineer to apply his past experience to current problems. In our investigations, samples obtained during drilling operations are examined in our laboratory and visually classified by an engineer. The soils are classified according to consistency (based on number of blows from standard penetration tests), color and texture. These classification descriptions are included on our Boring Logs.

The classification system discussed above is primarily qualitative and for detailed soil classification two laboratory tests are necessary; grain size tests and plasticity tests. Using these test results the soil can be classified according to the AASHTO or Unified Classification Systems (ASTM D-2487). Each of these classification systems and the in-place physical soil properties provides an index for estimating the soil's behavior. The soil classification and physical properties are presented in this report.

The following table presents criteria that are typically utilized in the classification and description of soil and rock samples for preparation of the Boring Logs.

Relative Density of Cohesionless Soils From Standard Penetration Test		Consistency of Cohesive Soils	
Very Loose	≤ 4 bpf	Very Soft	≤ 2 bpf
Loose	5 - 10 bpf	Soft	3 - 4 bpf
Medium Dense	11 - 30 bpf	Firm	5 - 8 bpf
Dense	31 - 50 bpf	Stiff	9 - 15 bpf
Very Dense	> 50 bpf	Very Stiff	16 - 30 bpf
		Hard	30 - 50 bpf
		Very Hard	> 50 bpf
(bpf = blows per foot, ASTM D 1586)			
Relative Hardness of Rock		Particle Size Identification	
Very Soft	Hard Rock disintegrates or easily compresses to touch; can be hard to very hard soil.	Boulders	Larger than 12"
		Cobbles	3" - 12"
Soft	May be broken with fingers.	Gravel	
		Coarse	3/4" - 3"
Moderately Soft	May be scratched with a nail, corners and edges may be broken with fingers.	Fine	4.76mm - 3/4"
		Sand	
		Coarse	2.0 - 4.76 mm
Moderately Hard	Light blow of hammer required to break samples.	Medium	0.42 - 2.00 mm
		Fine	0.42 - 0.074 mm
Hard	Hard blow of hammer required to break sample.	Fines (Silt or Clay)	Smaller than 0.074 mm
Rock Continuity		Relative Quality of Rocks	
RECOVERY = $\frac{\text{Total Length of Core}}{\text{Length of Core Run}} \times 100 \%$		RQD = $\frac{\text{Total core, counting only pieces } > 4" \text{ long}}{\text{Length of Core Run}} \times 100 \%$	
<u>Description</u>	<u>Core Recovery %</u>	<u>Description</u>	<u>RQD %</u>
Incompetent	Less than 40	Very Poor	0 - 25 %
Competent	40 - 70	Poor	25 - 50 %
Fairly Continuous	71 - 90	Fair	50 - 75 %
Continuous	91 - 100	Good	75 - 90 %
		Excellent	90 - 100 %