

The Enclosed Document Is Provided For Your Convenience.

Please Email ALL Questions:

[MailTo:ContractAdministration@TampaGov.net](mailto:ContractAdministration@TampaGov.net)

Please Let Us Know If You Plan To Bid

City of Tampa
Contract Administration Department
306 E. Jackson St. #280A4N
Tampa, FL 33602
(813)274-8456

CITY OF
TAMPA, FLORIDA

NOTICE TO BIDDERS, INSTRUCTIONS TO BIDDERS
PROPOSAL, BID BOND, FORM OF NOTICE OF AWARD,
AGREEMENT, PERFORMANCE BOND AND
SPECIFICATIONS

FOR

Contract 18-C-00030

City-wide Meter, Hydrant, Valve Installation and Replacement

City of Tampa
CONTRACT ADMINISTRATION DEPARTMENT
TAMPA MUNICIPAL OFFICE BUILDING
306 E. JACKSON STREET - 4TH FLOOR NORTH
TAMPA, FLORIDA 33602

JUNE 2018

CITY OF TAMPA
CONTRACT ADMINISTRATION DEPARTMENT
306 E. Jackson Street 280A4N
Tampa, FL 33602

BID NOTICE MEMO

Bids will be received no later than 1:30 p.m. on the indicated Date(s) for the following Project(s):

CONTRACT NO.: 18-C-00030; City-wide Meter, Hydrant and Valve Installation and Replacement
BID DATE: July 24, 2018 **ESTIMATE:** \$2,000,000 **SCOPE:** The project comprises furnishing all labor, materials, and equipment for installing water mains and appurtenances ranging in size from 2-inch to 16-inch diameter including concrete masonry, curbs and sidewalks; paving, landscaping, grouting, brick street construction, with all associated work required for a complete project in accordance with the Contract Documents. **PRE-BID CONFERENCE:** Tuesday, July 10, 2018, 2:30p.m. Attendance is not mandatory, but recommended.

Bids will be opened in the 4th Floor Conference Room, Tampa Municipal Office Building, 306 E. Jackson Street, Tampa, Florida 33602. Pre-Bid Conference is held at the same location unless otherwise indicated. Plans and Specifications and Addenda for this work may be examined at, and downloaded from, www.demandstar.com. Backup files are available at <http://www.tampagov.net/contract-administration/programs/construction-project-bidding>. Email Questions to: contractadministration@tampagov.net .

TABLE OF CONTENTS

BIDDING REQUIREMENTS

Notice to BiddersN-1
Instructions to BiddersI-1a thru I-4
Insurance RequirementsINS-1 thru INS-2
MBD-701
U-WMBE Availability Contact ListACL-1
Goal Setting List InstructionsGSL-1
Sample Solicitation LetterSL-1

BID FORMS

ProposalP-1 thru P-18
Good Faith Efforts Compliance PlanGFECF
DMI SolicitedDMI - Solicited
DMI UtilizedDMI - Utilized
Bid BondBB-1

CONTRACT FORMS

AgreementA-1 thru A-15
Public Construction BondPB-1 thru PB-3

GENERAL PROVISIONS

General ProvisionsG-1 thru G-10
Subcontractors Payment FormDMI - Payments
Project SignSign-1 thru Sign-2

SPECIFICATIONS

Specific ProvisionsSP-1 thru SP-21
Contract Pay ItemsCP-1 thru CP-46
Technical SpecificationsTS-1 thru TS-45
Water Material SpecificationsMS-1 thru MS-46
Standard Details

NOTICE TO BIDDERS
CITY OF TAMPA, FLORIDA
Contract 18-C-00030; City-wide Meter, Hydrant, Valve Installation and Replacement

Sealed Proposals will be received by the City of Tampa no later than 1:30 P.M., July 24, 2018, in the 4th Floor Conference Room, Tampa Municipal Office Building, 306 E. Jackson Street, Tampa, Florida, there to be publicly opened and read aloud.

The proposed work is to include, but not be limited to, furnishing and installing water mains and appurtenances ranging in size from 2-inch to 16-inch diameter including concrete masonry, curbs and sidewalks; paving, landscaping, grouting, brick street construction with all associated work required for a complete project in accordance with the Contract Documents.

The Instructions to Bidders, Proposal, Form of Bid Bond, Agreement, Form of Public Construction Bond, Specifications, Plans and other Contract Documents are posted at DemandStar.com. Backup files may be downloaded from <http://www.tampagov.net/contract-administration/programs/construction-project-bidding>. One set may be available for reference at the office of the Contract Administration Department, Municipal Office Building, Fourth Floor North, City Hall Plaza, Tampa, Florida 33602.

Each Proposal must be submitted on the Proposal form included in the Specifications and must be accompanied by a certified check or cashier's check on a solvent bank or trust company in compliance with Section 255.051, Florida Statutes, made payable to the City of Tampa, in an amount of not less than five per cent of the total bid, or a Bid Bond, of like amount, on the form set forth in the Contract Documents, as a guarantee that, if the Proposal is accepted, the Bidder will execute the Proposed Contract and furnish a Public Construction Bond within twenty (20) days after receipt of Notice of Award of Contract.

To be eligible to submit a proposal, a Bidder must hold the required and/or appropriate current license, certificate, or registration (e.g. DBPR license/certificate of authorization, etc.) in good standing at the time of receipt of Bids. **Per Section 489.131, Florida Statutes, Proposals submitted for the construction, improvement, remodeling, or repair of public projects must be accompanied by evidence that the Bidder holds the required and/or appropriate current certificate or registration, unless the work to be performed is exempt under Section 489.103, Florida Statutes.**

The City of Tampa reserves the right to reject any or all Bids and to waive any informalities in the Bid and/or Bid Bond. Acceptance or rejection of Proposals will be made as soon as practicable after the Proposals are received, but the City reserves the right to hold Proposals for ninety (90) days from the date of Opening.

Bid Protest Procedures: Unless subsequently indicated otherwise, in a revised posting on the Department's web page for Construction Project Bidding, the City of Tampa intends to award the referenced project to the lowest bidder listed in the tabulation posted on or about the date of Bid Opening. A bidder aggrieved by this decision may file a protest not later than 4:30 P.M., five (5) business days from the first posting thereof, pursuant to City of Tampa Code Chapter 2, Article V, Division 3, Section 2-282, Procurement Protest Procedures. Protests not conforming therewith shall not be reviewed.

Pursuant to Section 2-282, City of Tampa Code, during the solicitation period, including any protest and/or appeal, NO CONTACT with City officers or employees is permitted from any bidder or proposer, other than as specifically stated in this solicitation and as follows:
Director of the Contract Administration Department (CAD)
Contracts Management Supervisor, Jim Greiner
Contract Officer, Jody Gray
City legal department

Any Requests For Information must be submitted by email to ContractAdministration@tampagov.net

A person or affiliate who has been placed on the convicted vendor list following a conviction for a public entity crime may not submit a bid on a contract to provide any goods or services to a public entity, may not submit a bid on a contract with a public entity for the construction or repair of a public building or public work, may not submit bids on leases of real property to a public entity, may not be awarded or perform work as a contractor, supplier, subcontractor, or consultant under a contract with any public entity, and may not transact business with any public entity in excess of the threshold amount provided in Section 287.017, for CATEGORY TWO for a period of 36 months from the date of being placed on the convicted vendor list." Refer to Section 287.133, Florida Statutes.

Pursuant to Section 287.087, Florida Statutes, under certain circumstances preference may be given to businesses with a drug-free workplace program that meets the requirements of said Section.

INSTRUCTIONS TO BIDDERS
SECTION 1 - SPECIAL INSTRUCTIONS

I-1.01 GENERAL:

The proposed work is the City-wide Meter, Hydrant, Valve Installation and Replacement in the City of Tampa, as required for a complete project, as shown on the plans and detailed in the specifications. The work is located on land owned or controlled by the City of Tampa.

To be eligible to submit a proposal, a Bidder must hold the required and/or appropriate current license, certificate, or registration (e.g. DBPR license/certificate of authorization, etc.) in good standing at the time of receipt of Bids. **Per Section 489.131, Florida Statutes, Proposals submitted for the construction, improvement, remodeling, or repair of public projects must be accompanied by evidence that the Bidder holds the required and/or appropriate current certificate or registration, unless the work to be performed is exempt under Section 489.103, Florida Statutes.**

I-1.02 FORM PREPARATION AND PRESENTATION OF PROPOSALS: Replace the second sentence with the following: Submission of the entire specification book is not required.

I-1.03 ADDENDA – Section I-2.03 is replaced with the following: No interpretation of the meaning of the Plans, Specifications, or other Contract Documents will be made to any Bidder orally.

Every request for such interpretation must be in writing, addressed to the City of Tampa, Contract Administration Department, 306 E. Jackson St., 4th Floor, Tampa, Florida 33602 and then emailed to ContractAdministration@tampagov.net. To be given consideration, such request must be received at least seven (7) days prior to the date fixed for the opening of the Proposals. Any and all such interpretations and any supplemental instructions will be in the form of written addenda which, if issued, will be posted on DemandStar.Com and on the Department's web page, with notice given to all prospective bidders at the respective fax numbers or e-mail addresses furnished, for such purposes. Failure of any Bidder to receive any such addenda shall not relieve said Bidder from any obligation under his Proposal as submitted. All addenda so issued shall become part of the Contract Documents.

I-1.04 INSTRUCTIONS TO BIDDERS

SECTION 2 – GENERAL INSTRUCTIONS. Section I-2.07 SIGNATURE AND QUALIFICATIONS OF BIDDERS is replaced with the following:

Proposals must be signed in ink by the Bidder with signature in full. When firm is a Bidder, the Proposal shall be signed in the name of the firm by one or more partners. When a corporation is a bidder the officer signing shall set out the corporate name in full beneath which he shall sign his name and give the title of his office.

If the bidder referred to in Section I-2.07 is a corporation, it must submit; upon request, a copy of its filed Articles of Incorporation. In addition, if the bidder was incorporated in another state, it must establish that it is authorized to do business in the State of Florida. If the bidder is using a fictitious name, it must submit upon request, proof of registration of such name with the Clerk of the Circuit Court of the County where its principal place of business is. Failure to submit what is required is grounds to reject the bid of that bidder.

SECTION 2 – GENERAL INSTRUCTIONS. Section I-2.14 NONDISCRIMINATION IN EMPLOYMENT is changed to add the following to the end of the existing text:

The following provisions are hereby incorporated into any contract executed by or on behalf of the City. Contractor shall comply with the following Statement of Assurance: During the performance of the Contract, the Contractor assures the City, that the Contractor is in compliance with Title VII of the 1964 Civil Rights Act, as amended, the Florida Civil Rights Act of 1992, and the City of Tampa Code of Ordinances, Chapter 12, in that Firm/Contractor does not on the grounds of race, color, national origin, religion, sex, sexual orientation, gender identity or expression, age, disability, familial status, or marital status, discriminate in any form or manner against said Firm's/Contractor's employees or applicants for employment. Contractor understands and agrees that the Contract is conditioned upon the veracity of this Statement of Assurance, and that violation of this condition shall be considered a material breach of the Award/Contract. Furthermore, Contractor herein assures the City that said Contractor will comply with Title VI of the Civil Rights Act of 1964 when federal grant(s) is/are

INSTRUCTIONS TO BIDDERS
SECTION 1 - SPECIAL INSTRUCTIONS

involved. This Statement of Assurance shall be interpreted to include Vietnam-Era Veterans and Disabled Veterans within its protective range of applicability. Firm/Contractor further acknowledges and agrees to provide the City with all information and documentation that may be requested by the City from time to time regarding the solicitation, selection, treatment and payment of subcontractors, suppliers and vendors in connection with this Award/Contract. Firm/Contractor further acknowledges that it must comply with City of Tampa Code of Ordinances, Chapter 26.5, as enacted by Ordinance No. 2008-89.

I-1.05 TIME FOR COMPLETION:

The work shall be arranged to be completed in accordance with a progress schedule approved by the Construction Engineer.

The time for completion of this project, referred in Article 4.01 of the Agreement, shall be 365 consecutive calendar days. The period for performance shall start from the date indicated in the Notice To Proceed.

I-1.06 LIQUIDATED DAMAGES:

The amount of liquidated damages, referred to in Article 4.06 of the Agreement, for completion of this project shall be \$500 per calendar day.

I-1.07 BASIS OF AWARD OF CONTRACT:

The basis of award referred to in Item I-2.11 of Instructions to Bidders shall be the greatest amount of work, which can be accomplished within the funds available as budgeted. The award may be made on the basis of the total bid, base bid, alternates(s) if any, unit bids if any, or any combination thereof deemed to be in the best interest of the City.

The actual amount of an award may be adjusted to suit funds available. The City, at its option, may award to multiple bidders. The work will be completed in subsequently issued Work Orders. Unless all bids are rejected, the award will be made within 90 days after opening proposals.

Contract can be renewed for 2 additional 1 year periods, if agreeable to both parties and if funds are available. To renew the contract for an additional 1 year period the Contractor must notify the City, in writing that he desires renewal of the contract. The letter must be received by the City at least 120 days prior to contract expiration. The City shall respond to the Contractor's renewal request at least 90 days prior to the contract expiration.

I-1.07.1 Cost Escalation:

The cost escalation factor will be applied only as part of the renewal **CONTRACT**.

The method for adjusting the unit price of each Bid Proposal item uses construction economic information regularly published in *ENR (Engineering News-Record)*. Each Bid Proposal item unit cost is multiplied by the cost escalation factor (CEF) which is calculated as follows:

$$CEF = \frac{\text{Average index at renewal time (months) after NTP}}{\text{Average index at NTP}}$$

where,

$$\text{Average index} = \frac{\text{Skilled Labor Index} + \text{Materials Cost Index}}{2}$$

INSTRUCTIONS TO BIDDERS
SECTION 1 - SPECIAL INSTRUCTIONS

Example:

NTP issued November 15, 2012

<i>Average index at NTP=</i>	$\frac{8997.42 + 2900.75}{2}$	= 5949.09
	2	

<i>Average index nine months after NTP</i>	$\frac{9128.56 + 2974.21}{2}$	= 6051.39
	2	

<i>CEF=</i>	$\frac{6051.39}{5949.09}$	= 1.0172
	5949.09	

Note: Nine months is used as an example only. The date used for the formula will be the contract renewal date. If the value of the CEF is less than or equal to one, the line item prices will remain the same. If the value of the CEF is greater than 1.0, the Bid proposal line item prices will be multiplied by the new adjusted CEF. The cost adjustment will take effect at the beginning of the **CONTRACT** renewal period.

In no event shall either the escalation or the de-escalation exceed 5% percent in any one contract term.

I-1.07.2 Contract Estimated Quantities:

Unit quantities indicated in the bid proposal Section of the bid document are provided as a means of comparing bid proposals and as a basis for award. However, these quantities are estimated, and actual unit quantities may vary greatly during the term of this contract. THE BIDDER IS ADVISED THAT THE TOTAL QUANTITY OF WORK REQUESTED MAY BE LESS THAN THE QUANTITY ESTIMATED IN THE BID PROPOSAL PAGES.

Bidders are cautioned against predicting their bid prices on an assumed scope of work or estimated bid quantities. The amount of award represents only the upper dollar limit beyond which no further work shall be ordered, except as may be approved by the City through Change Order. It is not known how much or how little work will be ordered during the term of this **CONTRACT**.

The CONTRACTOR acknowledges that actual quantities may be less than those indicated in the bid, and agrees that he will not make any claim for damages or for loss of profits because of a difference between the quantities shown in Bid proposal and the quantities of work actually ordered.

Total purchases shall not exceed the amount awarded by the City, and no work shall be commenced which is not provided for by the provisions of the **CONTRACT**.

Basis for payment shall be actual field measurement, not estimated bid or plan quantities.

I-1.08 GROUND BREAKING CEREMONY:

Arrangement may be made by the City in coordination with the Contractor, for construction to commence with a Ground Breaking Ceremony. Details will be discussed at the pre-construction conference.

INSTRUCTIONS TO BIDDERS
SECTION 1 - SPECIAL INSTRUCTIONS

I-1.09 INSURANCE:

The insurance required for this project shall be as indicated on the attached and incorporated Special Instructions pages beginning with page INS-1 entitled CITY OF TAMPA INSURANCE REQUIREMENTS, which among other things requires the Contractor to provide a Certificate of Insurance to the City prior to commencing work. The City may from time to time use a third party vendor to manage its insurance certificates and related documentation which vendor may periodically initiate contact, requests for information, etc. on the City's behalf.

I-1.10 EQUAL BUSINESS OPPORTUNITY PROGRAM (EBO) REQUIREMENTS / PROJECT SUBCONTRACTING GOAL(S)

BIDDERS MUST SUBMIT COMPLETED AND SIGNED CITY OF TAMPA FORMS MBD-10 AND MBD-20 WITH THEIR BIDS. BIDS SUBMITTED WITHOUT THESE COMPLETED FORMS (INCLUDING SIGNATURES) WILL BE DEEMED NON-RESPONSIVE. INSTRUCTIONS ON COMPLETING THE FORMS ARE INCLUDED AFTER EACH FORM IN THIS BID PACKAGE.

THE CHECKED BOX INDICATES SECTION THAT APPLIES TO THIS BID.

SUBCONTRACTING GOAL – (WMBE and SLBE)

In accordance with the City of Tampa's EBO Program, Chapter 26.5, City of Tampa Code, the subcontracting goal(s) has/have been established for subcontracting with City-certified underutilized WMBEs (Women and Minority Business Enterprises) and/or SLBEs (Small Local Business Enterprises) on this project (hereinafter "Goal"). *The Goal is based, in part, upon the availability of City-certified firms to perform the anticipated scope of work (Bid is subject to the subcontracting project goal(s) section for which a corresponding numerical percent is indicated).* Project Industry Category: Construction

- Project Goal(s): 30.0% **U-WMBE (Underutilized Woman and Minority Business Enterprise) (EBO Program)**
per MBD Form-70 the U-WMBE subcontract Classification for Construction is African American (BBE)
 % **SLBE (Small Local Business Enterprise) (EBO Program) only City-certified SLBEs**
 % **U-WMBE/SLBE Combined (EBO Program)**
per MBD Form-70 the U-WMBE subcontract Classification for Construction is African American (BBE) together with City-certified SLBEs
 % **WMBE/SLBE ASPIRATIONAL (EBO Program)** An all-inclusive SLBE/WMBE goal; any City certified firm counts towards goal attainment.

BIDDERS MUST SOLICIT ALL COMPANIES ON THE ATTACHED AVAILABILITY CONTACT LIST at least **five (5) City business days or more prior to bid opening as a first step** to demonstrate Good Faith Efforts to achieve the Goal. Substantive documentation that demonstrates Good Faith Efforts to achieve the Goal **must be submitted with the bid**, including emails, faxes, phone calls, letters, and other communication with City-certified firms. Bidders may explore other potential opportunities for subcontracting by consulting the current directory of all certified firms posted by the City of Tampa at <https://tampa.diversitysoftware.com> as the Availability Contact List may not be inclusive of all firms that could count toward Goal attainment. However, ONLY SUBCONTRACTING with those specific WMBEs designated as "underutilized" by Classification in the appropriate industry category (and, if made applicable by being specifically included in the above Goal, SLBEs) will count toward meeting the Goal. Making Good Faith Efforts through these and other means (not pro-forma) is the responsibility of the Bidder. See the attached Good Faith Effort Compliance Plan (GFCEP) (MBD Form-50) for specific requirements.

GOOD FAITH EFFORT COMPLIANCE PLAN (GFCEP) REQUIRED (MBD FORM-50). When a Goal has been established, the Bidder **must submit** with its bid a Good Faith Effort Compliance Plan (GFCEP) using the attached MBD Form-50 together with supporting documentation as specified therein. **Submittals that do not contain MBD Form-50 when a Goal has been established will be deemed non-responsive.** Additional explanation and documentation is required whenever a City-certified subcontractor's quote is not utilized. Any additional information regarding GFCEP (post-bid) shall be only upon the City's request for clarification of information submitted with bid and not to "cure" omissions or deficiencies of the bid.

NOTE: When U-WMBEs are included in a Goal, only those City-certified subcontractors whose WMBE Classification is designated "underutilized" will count toward Goal attainment. Refer to **MBD Form-70** to identify underutilized WMBEs by subcontract Classification for the applicable project industry category. A prime bidder who is a City-certified WMBE and/or SLBE is not exempt from the **GFCEP MBD Form-50** requirements.

SUBCONTRACTING GOAL – (DBE) FDOT DISADVANTAGED BUSINESS ENTERPRISE PROGRAM

The City of Tampa is required to use the Florida Department of Transportation (FDOT) Disadvantaged Business Enterprise (DBE) program on contracts with Federal Highway Administration (FHWA) funds. Effective October 1, 2017 through to September 30, 2020, the overall FDOT DBE aspirational goal is **10.65%** and is *race neutral*, meaning that FDOT believes the aspirational DBE goal may be achieved entirely through ordinary, competitive procurement methods. Despite the absence of a contract specific DBE goal on this project, the City encourages bidders to seek out and use DBEs and other minority, small businesses. For assistance in identifying certified DBEs, FDOT offers the use of its supportive services program accessed via FDOT's Equal Opportunity Office at <http://www.fdot.gov/equalopportunity/serviceproviders.shtml>. FDOT DBE rules and regulations apply to this solicitation, including the requirement to report bidder opportunity information in the FDOT Equal Opportunity Compliance (EOC) web-based application within three (3) business days of submission of the bid for ALL subcontractors who quoted bidder for this specific project. The five (5) char/digit LAP Agreement Contract Number for this project is G_____. The web address to the EOC system is: <https://fdotwp1.dot.state.fl.us/EqualOpportunityCompliance/Account.aspx/LogIn?ReturnUrl=%2fEqualOpportunityCompliance>

INSTRUCTIONS TO BIDDERS
SECTION 1 - SPECIAL INSTRUCTIONS

NOTE: Regardless of FDOT DBE program applicability, for data collection purposes bidder still **must submit** City Forms MBD-10 and MBD-20 completed and signed with its bid or the bid will be deemed non-responsive.

DIVERSITY MANAGEMENT INITIATIVE (DMI) DATA REPORTING FORMS REQUIRED FOR ALL CONTRACTS

Bidder **must submit**, with its bid, completed and signed Forms MBD-10 and MBD-20 to be considered a responsive bid. Specifically, the 'Schedule of All Solicited Sub-(Contractors/Consultants/Suppliers) (Form MBD-10)' listing all subcontractors (including non-certified) solicited and 'Schedule of All -To Be Utilized Sub-(Contractors/Consultants/Suppliers) (Form MBD-20)' listing all subcontractors (including non-certified) to be utilized. Supplemental forms, such as 'Form MBD-40 Official Letter Of Intent' (LOI), can be submitted with the bid or once declared lowest-responsive bidder. After an award, 'DMI Sub-(Contractors/Consultants/Suppliers) Payment Form (Form MBD-30)' is to be submitted with payment requests to report payments to subcontractors and using the on-line automated MBD compliance software system available at <https://tampa.diversitysoftware.com>

For additional information about the WMBE and SLBE programs contact the Minority and Small Business Development Office at 813-274-5522. (3-18)

I-1.11 BID SECURITY:

Surety companies shall have a rating of not less than B+ Class VI as evaluated in the most recently circulated Best KeyRating Guide Property/Casualty.

I-1.12 PUBLIC CONSTRUCTION BOND:

The Bidder who is awarded the Contract will be required to furnish a Public Construction Bond upon the form provided herein, equal to 100 percent of the Contract price, such Bond to be issued and executed by (a) surety company(ies) acceptable to the City and licensed to underwrite contracts in the State of Florida. After execution of the Agreement and before commencing work, the Contractor must provide the City a certified copy of the officially recorded Bond.

I-1.13 AGREEMENT

SECTION 2 – POWERS OF THE CITY'S REPRESENTATIVES, new Article 2.05:

Add the following:

Article 2.05 CITY'S TERMINATION FOR CONVENIENCE:

The City may, at any time, terminate the Contract in whole or in part for the City's convenience and without cause. Termination by the City under this Article shall be by a notice of termination delivered to the Contractor, specify the extent of termination and the effective date.

Upon receipt of a notice of termination, the Contractor shall immediately, in accordance with instructions from the City, proceed with performance of the following duties regardless of delay in determining or adjusting amounts due under this Paragraph:

- (a) cease operations as specified in the notice;
- (b) place no further orders and enter into no further subcontracts for materials, labor, services or facilities except as necessary to complete continued portions of the Contract;
- (c) terminate all subcontracts and orders to the extent they relate to the Work terminated;
- (d) proceed to complete the performance of Work not terminated; and
- (e) take actions that may be necessary, or that the City may direct, for the protection and preservation of the terminated Work.

The amount to be paid to the Contractor by the City because of the termination shall consist of:

- (a) for costs related to work performed on the terminated portion of the Work prior to the effective date including termination costs relative to subcontracts that are properly chargeable to the terminated portion of the Work;
- (b) the reasonable costs of settlement of the Work terminated, including accounting, legal, clerical and other expenses reasonable necessary for the preparation of termination settlement proposals and supporting data; additional costs of termination and settlement of subcontracts excluding amounts of such settlements; and storage, transportation, and other costs incurred which are reasonably necessary for the preservation, protection or disposition of the terminated Work; and
- (c) a fair and reasonable profit on the completed Work unless the Contractor would have sustained a loss on the entire Contract had it been completed.

INSTRUCTIONS TO BIDDERS
SECTION 1 - SPECIAL INSTRUCTIONS

Allowance shall be made for payments previously made to the Contractor for the terminated portion of the Work, and claims which the City has against the Contractor under the Contract, and for the value of materials supplies, equipment or other items that are part of the costs of the Work to be disposed of by the Contractor.

SECTION 5 – SUBCONTRACTS AND ASSIGNMENTS, Article 5.01, Page A-7, last paragraph:
Change "...twenty-five (25) percent..." to "...fifty-one (51) percent..."

SECTION 8 – CONTRACTOR'S EMPLOYEES, Article 8.03, Page A-9, delete Article 8.03 in its entirety and Replace with the following new article:

ARTICLE 8.03 EMPLOYMENT OPPORTUNITIES

The Contractor shall, in the performance of the work required to be done under this Contract, employ all workers without discrimination and must not maintain, provide or permit facilities that are segregated.

SECTION 10 – PAYMENTS, Article 10.05, Page A-10, 1st Paragraph, 1st Sentence:
Change "...fair value of the work done, and may apply for..." to "...fair value of the work done, and shall apply for..."

SECTION 11 – MISCELLANEOUS PROVISIONS, Article 11.02, Page A-12, 1st Paragraph, 2nd Sentence:
Delete the 2nd Sentence in its entirety and replace it with the following new 2nd Sentence:

Without limiting application of Article 11.07, below, whenever the Contractor is required or desires to use any design, device, material, or process covered by letters of patent or copyright, the Contractor shall indemnify, defend, and hold harmless the City Indemnified Parties (as defined below) from any and all Claims (as defined below) for infringement by reason of the use of any such patented design, device, tool, material, equipment, or process, to be performed under the Contract and damages which may be incurred by reason of such infringement at any time during the prosecution or after completion of the work.

SECTION 11 – MISCELLANEOUS PROVISIONS, Article 11.03, Page A-12:
Delete Article 11.03 in its entirety and replace with the following new article:

ARTICLE 11.03 INTENTIONALLY OMITTED.

SECTION 11 – MISCELLANEOUS PROVISIONS, Article 11.07, Page A-12:
Delete Article 11.07 in its entirety and replace with the following new article:

ARTICLE 11.07 INDEMNIFICATION PROVISIONS

Whenever there appears in this Agreement, or in the other Contact Documents made a part hereof, an indemnification provision within the purview of Chapter 725.06, Laws of Florida, the monetary limitation on the extent of the indemnification under each such provision shall be One Million Dollars or a sum equal to the total Contract price, whichever shall be the greater.

Contractor releases and agrees to defend, indemnify and hold harmless the City, its officers, elected and appointed officials, employees, and/or agents (collectively, "City Indemnified Parties") from and against any and all losses, liabilities, damages, penalties, settlements, judgments, charges, or costs (including without limitation attorneys' fees, professional fees, or other expenses) of every kind and character arising out of any and all claims, liens, is entitled to indemnification hereunder. This obligation shall in no way be limited in any nature whatsoever by any limitation on the amount or type of Contractor's insurance coverage.

The parties agree that to the extent the written terms of this indemnification are deemed by a court of competent jurisdiction to be in conflict with any provisions of Florida law, in particular Sections 725.06 and 725.08, Florida Statutes, the written terms of this indemnification shall be deemed by any court of competent jurisdiction to be modified in such a manner as to be in fully and complete compliance with all such laws and to contain such limiting conditions or limitations of liability, or to not contain any unenforceable or prohibited term or terms, such that this indemnification shall be enforceable in accordance with and to the maximum extent permitted by Florida law.

INSTRUCTIONS TO BIDDERS
SECTION 1 - SPECIAL INSTRUCTIONS

The obligation of Contractor under this Article is absolute and unconditional; it is not conditioned in any way on any attempt by a City Indemnified Party to collect from an insurer any amount under a liability insurance policy, and is not subject to any set-off, defense, deduction, or counterclaim that the Contractor might have against the City Indemnified Party. The duty to defend hereunder is independent and separate from the duty to indemnify, and the duty to defend exists regardless of any ultimate liability of Contractor, the City, and any City Indemnified Party. The duty to defend arises immediately upon presentation of a Claim by any party and written notice of such Claim being provided to Contractor. Contractor's defense and indemnity obligations hereunder will survive the expiration or earlier termination of this Contract.

Contractor agrees and recognizes that the City Indemnified Parties shall not be held liable or responsible for any Claims which may result from any actions or omissions of Contractor in which the City Indemnified Parties participated either through providing data or advice and/or review or concurrence of Contractor's actions. In reviewing, approving or rejecting any submissions by Contractor or other acts of Contractor, the City in no way assumes or shares any responsibility or liability of Contractor or any tier of subcontractor/subconsultant/supplier, under this Contract.

In the event the law is construed to require a specific consideration for such indemnification, the parties agree that the sum of Ten Dollars and 00/100 (\$10.00), receipt of which is hereby acknowledged, is the specific consideration for such indemnification and the providing of such indemnification is deemed to be part of the specifications with respect to the services provided by Contractor.

SECTION 11 – MISCELLANEOUS PROVISIONS, Article 11.12, Page A-13:

Change Article 11.12 to add the following new language after existing text:

The City of Tampa is a public agency subject to Chapter 119, Florida Statutes. In accordance with Florida Statutes, 119.0701, Contractor agrees to comply with Florida's Public Records Law, including the following:

1. Contractor shall keep and maintain public records required by the City to perform the services under this Agreement;
2. Upon request by the City, provide the City with copies of the requested records, having redacted records in total on in part that are exempt from disclosure by law or allow the records to be inspected or copied within a reasonable time (with provision of a copy of such records to the City) on the same terms and conditions that the City would provide the records and at a cost that does not exceed that provided in Chapter 119, Florida Statutes, or as otherwise provided by law;
3. Ensure that records, in part or in total, that are exempt or that are confidential and exempt from disclosure requirements are not disclosed except as authorized by law for the duration of the Agreement term and following completion (or earlier termination) of the Agreement if Contractor does not transfer the records to the City;
4. Upon completion (or earlier termination) of the Agreement, Contractor shall within 30 days after such event either transfer to the City, at no cost, all public records in possession of the Contractor or keep and maintain the public records in compliance with Chapter 119, Florida Statutes. If Contractor transfers all public records to the City upon completion (or earlier termination) of the Agreement, Contractor shall destroy any duplicate records that are exempt or confidential and exempt from public records disclosure requirements. If Contractor keeps and maintains public records upon completion (or earlier termination) of the Agreement, Contractor shall meet all applicable requirements for retaining public records. All records stored electronically must be provided to the City in a format that is compatible with the information technology systems of the agency.

INSTRUCTIONS TO BIDDERS
SECTION 1 - SPECIAL INSTRUCTIONS

The failure of Contractor to comply with Chapter 119, Florida Statutes, and/or the provisions set forth in this Article shall be grounds for immediate unilateral termination of the Agreement by the City; the City shall also have the option to withhold compensation due Contractor until records are received as provided herein.

IF CONTRACTOR HAS QUESTIONS REGARDING THE APPLICATION OF CHAPTER 119, FLORIDA STATUTES, TO CONTRACTOR'S DUTY TO PROVIDE PUBLIC RECORDS RELATING TO THIS AGREEMENT, CONTACT THE CUSTODIAN OF PUBLIC RECORDS AT 813-274-8598, JIM.GREINER@TAMPAGOV.NET, AND CONTRACT ADMINISTRATION DEPARTMENT, TAMPA MUNICIPAL OFFICE BUILDING, 4TH FLOOR, 306 E. JACKSON ST. TAMPA, FLORIDA 33602.

I-1.14 Contractors must utilize the U.S. Department of Homeland Security's E-Verify Systems to verify the employment eligibility of all persons employed during the term of the Contract to perform employment duties within the State of Florida and all persons, including subcontractors, assigned by Contractor to perform work pursuant to the contract.

I-1.15 GENERAL PROVISIONS; G-2.02 Copies Furnished to Contractor: Replace the first paragraph with the following:

The Contractor shall acquire for its use copies of the plans and specifications as needed, which may be downloaded from the City's web site, at <http://www.tampagov.net/contract-administration/programs/construction-project-bidding>.

Bidder as part of the solicitation process (and as Contractor if Bidder is successful) may hold, come into possession of, and/or generate certain building plans, blueprints, schematic drawings, including draft, preliminary, and final formats, which depict the internal layout and structural elements of a building, facility, or other structure owned or operated by the City or an agency (singularly or collectively "Exempt Plans"), which pursuant to Section 119.071(3), Florida Statutes, are exempt from Section 119.07(1), Florida Statutes and Section 24(a), Art. I of the Florida State Constitution. Contractor certifies it has read and is familiar the exemptions and obligations of Section 119.071(3), Florida Statutes; further that Contractor is and shall remain in compliance with same, including without limitation maintaining the exempt status of such Exempt Plans, for so long as any Exempt Plans are held by or otherwise in its possession.

I-1.16 PAYMENT DISPUTE RESOLUTION

Any dispute pertaining to pay requests must be presented to the City pursuant to Executive Order 2003-1.

I-1.17 SCRUTINIZED COMPANIES.

Section 287.135, Florida Statutes, prohibits agencies or local governmental entities from contracting with companies for goods or services of \$1 million or more that are on either the Scrutinized Companies with Activities in Sudan List or the Scrutinized Companies with Activities in the Iran Petroleum Energy Sector List, created pursuant to Section 215.473, Florida Statutes, or is on the Scrutinized Companies that Boycott Israel List, created pursuant to Section 215.4725, Florida Statutes, (effective October 1, 2016), or is engaged in a boycott of Israel (effective October 1, 2016), or is engaged in business operations in Cuba or Syria. A company that is on either the Scrutinized Companies with Activities in Sudan List or the

Scrutinized Companies with Activities in the Iran Petroleum Energy Sector List, created pursuant to Section 215.473, Florida Statutes, or is on the Scrutinized Companies that Boycott Israel List, created pursuant to Section 215.4725, Florida Statutes, (effective October 1, 2016) or is engaged in a boycott of Israel (effective October 1, 2016) or is engaged in business operations in Cuba or Syria is ineligible to, and may not, bid on, submit a proposal for, or enter into or renew a contract with an agency or

INSTRUCTIONS TO BIDDERS
SECTION 1 - SPECIAL INSTRUCTIONS

local governmental entity for goods or services of \$1 million or more. Contractor certifies that it is not in violation of Section 287.135, Florida Statutes. For contracts \$1,000,000 and greater, if the City determines the Contractor submitted a false certification under Section 287.135(5) of the Florida Statutes, or has been placed on the Scrutinized Companies with Activities in the Sudan List or the Scrutinized Companies with Activities in the Iran Petroleum Energy Sector List, or is on the Scrutinized Companies that Boycott Israel List, created pursuant to Section 215.4725, Florida Statutes, (effective October 1, 2016), or is engaged in a boycott of Israel (effective October 1, 2016), or been engaged in business operations in Cuba or Syria, the City shall either terminate the Agreement after it has given the Contractor notice and an opportunity to demonstrate the City's determination of false certification was in error pursuant to Section 287.135(5)(a) of the Florida Statutes, or maintain the Agreement if the conditions of Section 287.135(4) of the Florida Statutes are met.

I-1.18 FLORIDA'S PUBLIC RECORDS LAW; DATA COLLECTION

Pursuant to Section 119.071(5)(a)2a, Florida Statutes, social security numbers shall only be collected from Bidders and/or Contractor by the City should such number be needed for identification, verification, and/or tax reporting purposes. To the extent Bidder and/or Contractor collects an individual's social security number in the course of acting on behalf of the City pursuant to the terms and conditions of its Proposal or, if awarded, the Agreement, Bidder and/or Contractor shall follow the requirements of Florida's Public Records Law.

INSTRUCTIONS TO BIDDERS

SECTION 2 GENERAL INSTRUCTIONS

I-2.01 BIDDER'S RESPONSIBILITY

Before submitting Proposals, Bidders shall carefully examine the entire site of the proposed work and adjacent premises and the various means of approach and access to the site, and make all necessary investigations to inform themselves thoroughly as to the facilities necessary for delivering, placing and operating the necessary construction equipment, and for delivering and handling materials at the site, and inform themselves thoroughly as to all difficulties involved in the completion of all the work in accordance with the Contract Documents.

Bidders must examine the Plans, Specifications, and other Contract Documents and shall exercise their own judgment as to the nature and amount of the whole of the work to be done, and for the bid prices must assume all risk of variance, by whomsoever made, in any computation or statement of amounts or quantities necessary to complete the work in strict compliance with the Contract Documents.

Elevations of the ground are shown on the Plans and are believed to be reasonably correct, but are not guaranteed to be absolutely so and are presented only as an approximation. Bidders shall satisfy themselves as to the correctness of all elevations.

The City may have acquired, for its own use, certain information relating to the character of materials, earth formations, probable profiles of the ground, conditions below ground, and water surfaces to be encountered at the site of the proposed work. This information, if it exists, is on file at the offices of the Department of Public Works and Bidders will be permitted to see and examine this information for whatever value they consider it worth. However, this information is not guaranteed, and Bidders should satisfy themselves by making borings or test pits, or by such other methods as they may prefer, as to the character, location, and amounts of water, peat, clay, sand, quicksand, gravel, boulders, conglomerate, rock, gas or other material to be encountered or work to be performed.

Various underground and overhead structures and utilities are shown on the plans. The location and dimensions of such structures and utilities, where given, are believed to be reasonably correct, but do not purport to be absolutely so. These structures and utilities are plotted on the Plans for the information of the Bidders, but information so given is not to be construed as a representation or assurance that such structures will be found or encountered as plotted, or that such information is complete or accurate.

I-2.02 FORM, PREPARATION AND PRESENTATION OF PROPOSALS

Each Proposal shall be submitted upon the Proposal Form and in accordance with the instructions included herein. The Proposal Form must not be detached herefrom. All blank spaces for bid prices must be filled in, in both words and figures, with the unit or lump sum prices, or both, for which the Proposal is made. The computed total price for each unit price Contract Item shall be determined by multiplying the estimated quantity of the item, as set forth in the Proposal Form, by the corresponding unit price bid for such item. The resulting product shall be entered in the appropriate blank space under the column headed "Computed Total Price for Item". The lump sum price bid for each lump sum price Contract Item shall also be entered in the column headed "Computed Total Price for Item". If a Proposal contains any omissions, erasures, alterations, additions, or items not called for in the itemized Proposal, or contains irregularities of any kind, such may constitute sufficient cause for rejection of the Proposal. In case of any discrepancy in the unit price or amount bid for any item in the Proposal, the price as expressed in written words will govern. In no case is the Agreement Form to be filled out or signed by the Bidder.

In the case of certain jobs bid Lump Sum a "Schedule of Unit Prices" must be filled out as an attachment to the Lump Sum proposal. These prices may be used as a guide for the negotiation of change orders, at the City's option.

The proposal must be signed and certified and be presented on the prescribed form in a sealed envelope on/or before the time and at the place stated in the Notice of Bidders, endorsed with the name of the person, firm or corporation presenting it, the date of presentation, and the title of the work for which the Proposal is made.

Unless the apparent low bidder is now engaged in or has recently completed contract work for the City of Tampa, he, if requested, shall furnish to the City, after the opening of bids and prior to award, a summary statement of record of construction experience over the past three (3) years with proper supporting evidence, and, if required by the City, shall also furnish a list of equipment and other facilities pertinent to and available for the proper execution of the proposed work, and a statement of financial resources to the extent necessary to establish ability to carry on the proposed work. The City may make further investigations as considered necessary with respect to responsibility of the Bidder to whom it appears may be awarded the Contract.

If forwarded by mail, the sealed envelope containing the Proposal, endorsed as directed above, must be enclosed in another envelope addressed as specified in the Notice to Bidders and sent by registered mail.

I-2.03 ADDENDA AND INTERPRETATIONS

No interpretation of the meaning of the Plans, Specifications, or other Contract Documents will be made to any Bidder orally.

Every request for such interpretation must be in writing, addressed to the Contract Administration Department, Tampa Municipal Office Building, 4th Floor North, City Hall Plaza, Tampa, Florida 33602. To be given consideration, such request must be received at least seven (7) days prior to the date fixed for the opening of the Proposals. Any and all such interpretations and any supplemental instructions will be in the form of written addenda which, if issued, will be sent by certified mail, with return receipt requested, to all prospective bidders at the respective addresses furnished, for such purposes, not later than three (3) working days prior to the date fixed for the opening of the Proposals, and if requested, a copy will be delivered to the prospective bidder's representative. Failure of any Bidder to receive any such addenda shall not relieve said Bidder from any obligation under his Proposal as submitted. All addenda so issued shall become part of the Contract Documents.

I-2.04 BID SECURITY

Each Proposal must be accompanied by a certified or cashier's check issued by a solvent bank or trust company and payable at sight to the City of Tampa, in compliance with Section 255.051 Florida Statutes, or a Bid Bond upon the form provided herein, in an amount of not less than five percent of the sum of the computed total amount of the Bidder's Proposal as a guarantee that if the Proposal is accepted, the Bidder will execute and fill in the proposed Contract and Public Construction Bond within twenty (20) days after notice of award of the Contract. Certified checks shall have all necessary documentary revenue stamps attached if required by law. Surety on Bid Bonds shall be a duly authorized surety company authorized to do business in the State of Florida, and all such Bonds shall be issued or countersigned by a local resident producing agent, and satisfactory evidence of the authority of the person or persons executing such Bond to Execute the same shall be submitted with the Bond. Bid Bonds shall be issued by a surety company acceptable to the City.

Within ten (10) days after the opening of Proposals, the bid security of all but the three lowest Bidders will be returned. The bid security of the remaining two Bidders whose Proposals are not accepted will be

returned within ten (10) days after the execution of the Contract, or, if no such Contract has been executed, within ninety (90) days after the date of opening Proposals. The bid security of the Bidder whose Proposal is accepted will be returned only after he has duly executed the Contract and furnished the required Public Construction Bond and insurance.

Should it be necessary for the City to retain the bid security and said bid security is in the form of checks, the checks of these Bidders will be returned if replaced by Bid Bonds in an amount equal to the amount of the checks of such Bidders in such form and issued by a surety company acceptable to the City.

A Bidder may withdraw his Proposal before the time fixed for the opening of Proposals, without prejudice to himself, by communicating his purpose, in writing, to the Mayor and City Council, and when his communication is received, the Proposal will be handed to him or his authorized agent unopened. No Bidder may withdraw his Proposal within ninety (90) days after the day of opening Proposals.

The Bidder whose Proposal is accepted shall enter into a written contract, upon the Agreement form included herein, for the performance of the work and furnish the required Public Construction Bond within twenty (20) days after written notice by the City of Award of Contract has been served on such Bidder personally or after receipt of the written notice by registered mail to such Bidder at the address given in his Proposal.

If the Bidder to whom a Contract is awarded refuses or neglects to execute it or fails to furnish the required Public Construction Bond within twenty (20) days after receipt by him of the Notice of Award of Contract, the amount of his bid security shall be forfeited and shall be retained by the City as liquidated damages, and not as a penalty, it being now agreed that said sum is a fair estimate of the amount of damages that the City will sustain in case said Bidder fails to enter into a Contract and furnish the required Public Construction Bond. If a Bid Bond was furnished, the full amount of the Bond shall become due and payable as liquidated damages caused by such failure. The full amount of the bid security shall be forfeited as liquidated damages without consideration of the fact that an award may be less than the full amount of the Bidder's Proposal, excepting that the award shall be within the conditions of said Proposal relating to the basis of consideration for an award. No plea of mistake in the bid or misunderstanding of the conditions of forfeiture shall be available to the Bidder for the recovery of his deposit or as a defense to any action based upon the neglect or refusal to execute a contract.

I-2.05 LAWS AND REGULATIONS

The Bidder who is awarded the Contract must comply with all laws of the State of Florida, and all applicable Ordinances of the City of Tampa respecting labor and compensation and with all other statutes, ordinances, rules and regulations applicable and having the force of law.

I-2.06 PUBLIC CONSTRUCTION BOND

The Bidder who is awarded the Contract will be required to furnish a Public Construction Bond upon the form provided herein, equal to 100 percent of the Contract price, such Bond to be executed by a surety company acceptable to the City of Tampa and licensed to underwrite contracts in the State of Florida. Surety companies shall have a rating of not less than: B+ Class VI as evaluated in the most recently circulated BEST'S KEY RATING GUIDE PROPERTY-LIABILITY.

I-2.07 SIGNATURE AND QUALIFICATIONS OF BIDDERS

Proposals must be signed in ink by the Bidder with signature in full. When a firm is a Bidder, the Proposal shall be signed in the name of the firm by one or more of the partners. When a corporation is a Bidder the officer signing shall set out the corporate name in full beneath which he shall sign his name and give the title of his office. The Proposal shall also bear the seal of the corporation attested by its secretary. Anyone signing the Proposal as agent must file with it legal evidence of his authority to do so.

Bidders who are nonresident corporations shall furnish to the City a

duly certified copy of their permit to transact business in the State of Florida, signed by the Secretary of State, within ten days of the notice to do so. Such notice will be given to Bidders who are nonresident corporations, to whom it appears an award will be made, and the copy of the permit must be filed with the City before the award will be made. Failure to promptly submit this evidence of qualification to do business in the State of Florida may be basis for rejection of the Proposal.

I-2.08 REJECTION OF PROPOSALS

The City reserves the right to reject any Proposal if investigation of the Bidder fails to satisfy the City that such Bidder is properly qualified to carry out the obligations and to complete the work contemplated therein. Any or all Proposals will be rejected if there is reason to believe that collusion exists among Bidders. Proposals will be considered irregular and may be rejected if they show serious omissions, alterations in form, additions not called for, conditions or unauthorized alternates, or irregularities of any kind. The City reserves the right to reject any or all Proposals and to waive such technical errors as may be deemed best for the interests of the City.

I-2.09 QUANTITIES ESTIMATED ONLY

The estimate of quantities of the various items of work and materials, if set forth in the Proposal Form, is approximate only and is given solely to be used as a uniform basis for the comparison of Proposals.

The quantities actually required to complete the Contract work may be less or more than so estimated, and if awarded a Contract for the work specified, the Contractor agrees that he will not make any claim for damages or for loss of profits because of a difference between the quantities of the various classes of work assumed for comparison of Proposals and quantities of work actually performed. The City further reserves the right to vary the quantities in any amount.

I-2.10 COMPARISON OF PROPOSALS

Except jobs bid on a "One Lump Sum" basis, proposals will be compared on the basis of a total computed price arrived at by taking the sum of the estimated quantity of each item and the corresponding unit price of each item, and including any lump sum prices on individual items.

The computed total prices for individual Contract Items and the total computed price for the entire Contract, as entered by the Bidder in the Proposal Form, are for convenience only and are subject to correction in the tabulation and computation of the Proposals.

I-2.11 BASIS OF AWARD

The Contract will be awarded, if at all, to the lowest responsible Bidder or Bidders, as determined by the City and by the terms and conditions of the Contract Documents. Unless all bids are rejected, the award will be made within ninety (90) days after the opening of Proposals. The successful Bidder will be required to possess, or obtain, a valid City Occupational License.

I-2.12 INSURANCE REQUIRED

The successful Bidder and his subcontractors will be required to procure and pay for insurance covering the work in accordance with the provisions of Article 6.02 of the Agreement as indicated on special instructions pages beginning with INS-1.

I-2.13 NO ASSIGNMENT OF BID

No Bidder shall assign his bid or any rights thereunder.

I-2.14 NONDISCRIMINATION IN EMPLOYMENT

Contracts for work under this Proposal will obligate the contractors and subcontractors not to discriminate in employment practices.

Bidders must, if requested, submit with their initial bid a signed statement as to whether they have previously performed work subject to the President's Executive Order Nos. 11246 and 11375.

Bidders must, if requested, submit a compliance report concerning their employment practices and policies in order to maintain their eligibility to receive the award of the Contract.

Successful Bidders must, if requested, submit a list of all subcontractors who will perform work on the project and written,

signed statement from authorized agents of the labor pools with which they will or may deal for employees on the work together with supporting information to the effect that said labor pools practices and policies are in conformity with Executive Order No. 11246 and that said labor pools will affirmatively cooperate in or offer no hindrance to the recruitment, employment and equal treatment of employees seeking employment and performing work under the Contract, or a certification as to what efforts have been made to secure such statements when such agents or labor pools have failed or refused to furnish them prior to the award of the Contract.

I-2.15 LABOR STANDARDS

The Bidder's attention is directed to the Contract Provisions of the Labor Standards for federally assisted projects which may be attached to and made a part of the Agreement.

I-2.16 NOTICE TO LABOR UNIONS

If applicable, the successful Bidder will be required to provide Labor Unions and other organizations of workers a completed copy of the form entitled "Notice to Labor Unions or Other Organizations of Workers", and such form may be made a part of the Agreement.

I-2.17 NOTICE TO PROSPECTIVE FEDERALLY-ASSISTED CONSTRUCTION CONTRACTORS

A Certification of Nonsegregated Facilities, as required by the May 9, 1967, Order (32 F.R. 7439, May 19, 1967) on Elimination of Segregated Facilities, by the Secretary of Labor, must be submitted to said Secretary prior to the award of a federally-assisted construction and Contract exceeding \$10,000 which is not exempt from the provisions of the Equal Opportunity Clause. The form of certification may be bound herein following the form of Bid Bond.

Contractors receiving federally-assisted construction Contract awards exceeding \$10,000 which are not exempt from the provisions of the Equal Opportunity Clause will be required to provide for the forwarding of the following notice to prospective subcontractor for supplies and construction contracts where the subcontracts exceed \$10,000 and are not exempt from the provisions of the Equal Opportunity Clause:

NOTICE TO PROSPECTIVE SUBCONTRACTORS OF REQUIREMENT FOR CERTIFICATIONS OF NONSEGREGATED FACILITIES

"A Certification of Nonsegregated Facilities, as required by the May 9, 1967, Order (32 F.R. 7439, May 19, 1967) on Elimination of Segregated Facilities, by the Secretary of Labor, must be submitted prior to the award of a subcontract exceeding \$10,000 which is not exempt from the provisions of the Equal Opportunity Clause."

"Contractors receiving subcontract awards exceeding \$10,000 which are not exempt from the provisions of the Equal Opportunity Clause will be required to provide from the forwarding of this notice to prospective subcontractors for supplies and construction contracts where the subcontracts exceed \$10,000 and are not exempt from the provisions of the Equal Opportunity Clause."

The United States requires a pre-award conference if a proposed construction contract exceeds one million dollars to determine if the the prospective contractor is in compliance with the Equal Employment Opportunity requirements of Executive Order 11246 of September 24, 1965. In such instances, a meeting may be scheduled at which the prospective contractor must specify what affirmative action he has taken or proposed to take to assure equal employment opportunity which must be approved by the United States before award of the contract will be authorized.

Bidders must be prepared to submit an Equal Employment Opportunity (EEO) plan at a pre-award conference. The plan must include bidding opportunities offered by the Bidder to minority subcontractors.

On October 13, 1971, President Nixon issued Executive Order 11246 emphasizing the government's commitment to the promotion of minority business enterprise. Accordingly, the United States is firmly

committed to the utilization of available resources to support this important program. U.S. agencies are most interested in realizing minority participation on the subject. Achieving equal employment opportunity compliance is required through Executive Order 11246. WE cannot emphasize too strongly that minority subcontractors be extended subcontractors bidding opportunities as but one step in your affirmative action policy.

Due to the importance of this contract, U.S. Agencies may conduct an EEO Conference prior to the award of the Contract. It is suggested that the responsive Bidder confirm the minority subcontractors he contacted for bids or quotations in his EEO plan submitted at the conference.

I-2.18 EEO AFFIRMATIVE ACTION REQUIREMENTS

By the submission of a Proposal, each Bidder acknowledges that he understands and will agree to be bound by the equal opportunity requirements of Federal regulations which shall be applicable throughout the performance of work under any contract awarded pursuant to solicitation. Each Bidder agrees that if awarded a contract, he will similarly bind contractually each subcontractor. In policies, each Bidder further understands and agrees that if awarded a contract, he must engage in Affirmative Action directed to promoting and ensuring equal employment opportunity in the work force used under the contract (and he must require contractually the same effort of all subcontractors whose subcontracts exceed \$100,000). The Bidder understands and agrees that "Affirmative Action" as used herein shall constitute a good faith effort to achieve and maintain minority employment in each trade in the on-site work force used on the project. ***** END of SECTION *****

CITY OF TAMPA INSURANCE REQUIREMENTS

Prior to commencing any work or services or taking occupancy under that certain written agreement or award (for purposes of this document, Agreement) between the City of Tampa, Florida (City) and Firm/Awardee/Contractor/Consultant/Lessee/non-City party, etc. (for purposes of this document, Firm) to which this document is attached and incorporated as an Exhibit or otherwise, and continuing during the term of said Agreement (or longer if the Agreement and/or this document so requires), Firm shall provide, pay for, and maintain insurance against claims for injuries to persons (including death) or damages to property which may arise from or in connection with the performance of the Agreement (including without limitation occupancy and/or use of certain property/premises) by Firm, its agents, representatives, employees, suppliers, subtenants, or subcontractors (which term includes sub-consultants, as applicable) of any tier subject to the terms and conditions of this document. Firm's maintenance of insurance coverage as required herein is a material element of the Agreement and the failure to maintain or renew coverage or provide evidence of same (defined to include without limitation Firm's affirmative duty to provide from time to time upon City's request certificates of insurance, complete and certified copies of Firm's insurance policies, forms, and endorsements, information on the amount of claims payments or reserves chargeable to the aggregate amount of coverage(s) whether during the term of the Agreement or after as may be requested by the City in response to an issue or potential claim arising out of or related to the Agreement to which Firm's insurance obligations hereunder may apply or possibly help mitigate) may be treated as a material breach of the Agreement. Should at any time Firm not maintain the insurance coverages required, City at its sole option (but without any obligation or waiver of its rights) may (i) terminate the Agreement or (ii) purchase such coverages as City deems necessary to protect itself (charging Firm for same) and at City's option suspending Firm's performance until such coverage is in place. If Firm does not reimburse City for such costs within 10 days after demand, in addition to any other rights, City shall also have the right to offset such costs from amounts due Firm under any agreement with the City. All provisions intended to survive or to be performed subsequent to the expiration or termination of the Agreement shall survive, including without limitation Firm's obligation to maintain or renew coverage, provide evidence of coverage and certified copies of policies, etc. upon City's request and/or in response to a potential claim, litigation, etc.

The City reserves the right from time to time to modify or waive any or all of these insurance requirements (or to reject policies) based on the specific nature of goods/services to be provided, nature of the risk, prior experience, insurer, coverage, financial condition, failure to operate legally, or other special circumstances. If Firm maintains broader coverage and/or higher limits than the minimums shown herein, the City requires and shall be entitled to such broader coverage and/or higher limits maintained by Firm. Any available insurance proceeds in excess of the specified minimum limits of insurance and coverage shall be available to the City. No representation is made that the minimum insurance requirements are sufficient to cover Firm's interests, liabilities, or obligations. Required insurance shall not limit Firm's liability.

Firm acknowledges and agrees Firm and not the City is the party in the best position to determine applicability (e.g. "IF APPLICABLE"), confirm, and/or verify its insurance coverage. Acceptance by the City, or by any of its employees, representatives, agents, etc. of certificates or other documentation of insurance or policies pursuant to the terms of this document and the Agreement evidencing insurance coverages and limits does not constitute approval or agreement that the insurance requirements have been met or that coverages or policies are in compliance. Furthermore, receipt, acceptance, and/or approval of certificates or other documentation of insurance or policies or copies of policies by the City, or by any of its employees, representatives, agents, etc., which indicate less coverage than required does not constitute a waiver of Firm's obligation to fulfill these insurance requirements.

MINIMUM SCOPE AND LIMIT OF INSURANCE ¹

A. Commercial General Liability (CGL) Insurance on the most current Insurance Services Office (ISO) Form CG 00 01 or its equivalent on an "occurrence" basis (Modified Occurrence or Claims Made forms are not acceptable without prior written consent of the City). Coverage must be provided to cover liability contemplated by the Agreement including without limitation premises and operations, independent contractors, contractual liability, products and completed operations, property damage, bodily, personal and advertising injury, contractual liability, explosion, collapse, underground coverages, personal injury liability, death, employees-as-insureds. Products and completed operations liability coverage maintained for at least 3 years after completion of work. Limits shall not be less than \$1M per occurrence and \$2M general aggregate for Agreements valued at \$2M or less; if valued over \$2M, a general aggregate limit that equals or exceeds the Agreement's value. If a general aggregate limit applies; it shall apply separately to the project/location (ISO CG 2S 03 or 2S 04 or equivalent). **(ALWAYS APPLICABLE)**

B. Automobile Liability (AL) Insurance in accordance with Florida law, as to the ownership, maintenance, and use of all owned, non-owned, leased, or hired vehicles. AL insurance shall not be less than: (a) \$500,000 combined single limit each occurrence bodily injury and property damage for Agreements valued at \$100,000 or less or (b) \$1M combined single limit each occurrence bodily injury and property damage for Agreements valued over \$100,000. If transportation of hazardous material involved, the MCS-90 endorsement (or equivalent). **(ALWAYS APPLICABLE)**

C. Worker's Compensation (WC) & Employer's Liability Insurance for all employees engaged under the Agreement, Worker's Compensation as required by Florida law. Employer's Liability with minimum limits of (a) \$500,000 bodily injury by accident and each accident, bodily injury by disease policy limit, and bodily injury by disease each employee for Agreements valued at \$100,000 and under or (b) \$1M bodily injury by accident and each accident, bodily injury by disease policy limit, and bodily injury by disease each for all other Agreements. **(ALWAYS APPLICABLE)**

D. Excess (Umbrella) Liability Insurance for Agreements valued at \$2M or more, at least \$4M per occurrence in excess of underlying limits and no more restrictive than underlying coverage for all work performed by Firm. May also compensate for a deficiency in CGL, AL, or WC. **(ALWAYS APPLICABLE)**

E. Builder's Risk Insurance for property loss exposure associated with construction/renovation/additions to buildings or structures, including materials or fixtures to be incorporated. Must be "All Risk" form with limits of no less than the project's completed value, have no coinsurance penalties, eliminate the "occupancy clause", cover Firm (together with its contractors, subcontractors of every tier, and suppliers), and name City as a Loss Payee. **(IF APPLICABLE)**

F. Installation Floater coverage for property (usually highly valued equipment or materials such as compressors, generators, etc.) during its installation. Coverage must be "All Risk" including installation and transit for no less than 100% of the installed replacement cost value. **(IF APPLICABLE)**

G. Architects & Engineers Liability/ Professional Liability (E&O)/ Contractors Professional Liability (CPL)/ Medical Malpractice Insurance where Agreement involves Florida-regulated professional services (e.g. architect, engineer, design-builder, CM, accountant, appraiser, investment banker medical professional) at any tier, whether employed or independent, vicarious design liability exposure (e.g. construction means & methods, design supervision), value engineering, constructability assessments/reviews, BIM process, and/or performance specifications. Limits of at least \$1M per occurrence and \$2M aggregate; deletion of design/ build liability exclusions, as applicable, and maintained for at least 3 years after completion of work/services and City's acceptance of same. **(IF APPLICABLE)**

H. Railroad Protective Liability CRPL Insurance for construction within 50ft of operated railroad track(s) or where affects any railroad bridge, trestle, tunnel, track(s) roadbed, or over/under pass. Subject to involved rail road's approval prior to commencement of work. **(IF APPLICABLE)**.

I. Pollution and/or Asbestos Legal Liability Insurance where Agreement involves asbestos and/or environmental hazards/contamination risks (defined broadly, e.g. lead, mold, bacteria, fuel storage, underground work, cleanup (owned or non-owned sites), pollutant generation/transportation, marine/natural resource damage, contamination claim, restitution, business interruption, mold, fungus, lead-based paint, 3rd party claims/removal, etc.), with limits of at least \$1M per occurrence and \$2M aggregate, maintained for at least 3 years after Agreement completion. **(IF APPLICABLE)**

J. Cyber Liability Insurance where Agreement involves portals allowing access to obtain, use, or store data; managed dedicated servers; cloud hosting services; software/hardware; programming; and/or other IT services

¹ "M" indicates million(s), for example \$1M is \$1,000,000

and products are involved. Limits of not less than \$2M per occurrence and \$2M aggregate. Coverage sufficiently broad to respond to duties and obligations undertaken by Firm, and shall include, but not be limited to, claims involving infringement of intellectual property/copyright, trademark, trade dress, invasion of privacy violations, damage to or destruction of electronic information, information theft, release of confidential and/or private information, alteration of electronic information, extortion, virus transmission, and network security. Coverage, as applicable and with sufficient limits to respond, for breach response costs, regulatory fines and penalties, credit monitoring expenses. **(IF APPLICABLE)**

K. Drone/UAV Liability Insurance where Agreements involves unmanned aerial vehicles/drones. Coverage to include products and completed operations, property damage, bodily injury with limits no less than \$1M per occurrence, and \$2M aggregate; may be provided by CGL endorsement subject to City's prior written approval. **(IF APPLICABLE)**

L. Longshore & Harbor Workers' Compensation Act/Jones Act for work being conducted near, above, or on "navigable waters" for not less than the above Employer's Liability Insurance limit. **(IF APPLICABLE)**

M. Garagekeeper/Hangerkeeper/Marina Operator Legal Liability Insurance and/or Hull/P&I Insurance where parking lot, valet, dealership, garage services, towing, etc. and/or operation of a hangar, marina, or air

plane/ship repairer, providing safe berth, air/watercraft storage/docking (on land/ in water), fueling, tours, charters, ferries, dredges, tugs, mooring, towing, boat/aircraft equipment/repair/alteration/maintenance, etc.; cover- age against liability for damage to vehicles air/watercraft, their machinery in Firm's care, custody, or control both private & commercial. Limits at least equal to greater of \$1M, value of max number of vehicles that may be in Firm's custody, or of most costly object in Firm's custody. **(IF APPLICABLE)**

N. Property Insurance and Interruption of Business CIOB) Insurance where premises, building, structure, or improved real property is leased, licensed, or otherwise occupied by Firm. Property Insurance against all risks of loss to any occupant/tenant improvements at full replacement cost with no coinsurance penalty, including fire, water, leak damage, and flood, as applicable, vandalism and malicious mischief endorsements. IOB by which minimum monthly rent will be paid to City for up to 1 year if premises are destroyed, rendered inaccessible or untenable, including disruption of utilities, water, or telecommunications. **(IF APPLICABLE)**

O. Liquor Liability/Host Liquor Liability where Firm directly or indirectly provides alcoholic beverages, limits of at least \$1M per occurrence and \$1M aggregate. **(IF APPLICABLE)**

P. Educators Legal Liability Insurance where day care, after school program, recreational activities, etc. limits per G above. **(IF APPLICABLE)**

ADDITIONAL REQUIREMENTS

ACCEPTABILITY OF INSURERS- Insurance is to be placed with insurers admitted in the State of Florida and who have a current A.M. Best rating of no less than **A-:VII** or, if not rated by A.M. Best, as otherwise approved by the City in advance and in writing.

ADDITIONAL INSURED - **City, its elected officials, departments, officers, officials, employees, and volunteers together with, as applicable, any associated lender of the City shall be covered as additional insureds on all liability coverage** (e.g. CGL, AL, and Excess (Umbrella) Liability) as to liability arising out of work or operations performed by or on behalf of Firm including materials, parts, or equipment furnished in connection with such work or operations and automobiles owned, leased, hired, or borrowed by or on behalf of Firm. Coverage can be provided in the form of an endorsement to Firm's insurance (at least as broad as ISO Form CG 20 10 11 85 or **both** CG 10 20, CG 20 26, CG 20 33, or CG 20 38 **and** CG 20 37 if later revisions used).

CANCELLATION/NON-RENEWAL - Each insurance policy shall provide that at least 30 days written notice must be given to City of any cancellation, intent to non-renew, or material reduction in coverage (except aggregate liability limits) and at least 10 days' notice for non-payment of premium. Firm shall also have an independent duty to notify City in like manner, within 5 business days of Firm's receipt from its insurer of any notices of same. If any policy's aggregate limit is reduced, Firm shall directly take steps to have it reinstated. Notice and proof of renewal/continued coverage/certifications, etc. shall be sent to the City's notice (or Award contact) address as stated in the Agreement with a copy to the following:

- Contract Administration Department, 306 E Jackson St, Tampa, FL 33602 Purchasing Department, 306 E Jackson Street, Tampa, FL 33602
 Other: _____

CERTIFICATE OF INSURANCE (COI) - to be provided to City by insurance carrier prior to Firm beginning any work/services or taking occupancy and, if the insurance expires prior to completion of the work or services or Agreement term (as may be extended), a renewal COI at least 30 days before expiration to the above address(es). COIs shall specifically identify the Agreement and its subject (project, lease, etc.), shall be sufficiently comprehensive to insure City (named as additional insured) and Firm and to certify that coverage extends to subcontractors' acts or omissions, and as to permit the City to determine the required coverages are in place without the responsibility of examining individual policies. **Certificate Holder must be The City of Tampa, Florida.**

CLAIMS MADE - If any liability insurance is issued on a claims made form, Firm agrees to maintain such coverage uninterrupted for at least 3 years following completion and acceptance of the work either through purchase of an extended reporting provision or purchase of successive renewals. The Retroactive Date must be shown and be a date not later than the earlier of the Agreement date or the date performance/occupancy began thereunder.

DEDUCTIBLES/ SELF-INSURED RETENTIONS (SIR) - must be disclosed to City and, if over \$500,000, approved by the City in advance and in writing, including at City's option being guaranteed, reduced, or eliminated (additionally if a SIR provides a financial guarantee guaranteeing payment of losses and related investigations, claim administration, and defense expenses). Firm shall be fully responsible for any deductible or SIR (without limiting the foregoing a policy with a SIR shall provide or be endorsed to provide that the SIR may be satisfied by either the City or named insured). In the event of loss which would have been covered but for a deductible or SIR, City may withhold from any payment due Firm, under any agreement with the City, an amount equal to same to cover such loss should full recovery not be obtained under the policy.

PERFORMANCE- All insurance policies shall be fully performable in Hillsborough County, Florida (the County), and construed in accordance with Florida law. Further, all insurance policies must expressly state that the insurance company will accept service of process in the County and that the exclusive venue for any action concerning any matter under those policies shall be in the appropriate state court of the County.

PRIMARY POLICIES - Firm's insurance coverage shall be primary insurance coverage at least as broad as ISO CG 20 01 04 13 as to the City, its elected officials, departments, officers, employees, and volunteers. Any insurance or self-insurance maintained by the City, its elected officials, departments, officers, employees, and volunteers shall be excess of the Firm's insurance and shall not contribute with it.

SUBCONTRACTORS/INDEPENDENT ASSOCIATES/CONSULTANTS/SUBTENANTS/SUBLICENSEE - **Firm shall require and verify that all such entities maintain insurance meeting all requirements stated herein with the City as an additional insured** by endorsement (ISO FORM CG 20 38, or broader) or otherwise include such entities within Firm's insurance policies. Upon City's request, Firm shall furnish complete and certified copies of copies of such entities' insurance policies, forms, and endorsements.

SUBCONTRACTOR DEFAULT INSURANCE CONTROLLED INSURANCE PROGRAM, WRAP-UP. Use requires express prior written consent of City Risk Manager.

UNAVAILABILITY- To the fullest extent permitted by law, if Firm is out of business or otherwise unavailable at the time a claim is presented to City, Firm hereby assigns to the City all of its right, title and interest (but not any liabilities or obligations) under any applicable policies of insurance.

WAIVER OF SUBROGATION - With regard to any policy of insurance that would pay third party losses, Firm hereby grants City a waiver of any right to subrogation which any insurer of Firm may acquire against the City by virtue of the payment of any loss under such insurance. Firm agrees to obtain any endorsement that may be necessary to affect such waiver, but this provision shall apply to such policies regardless.

WAIVER/RELEASE AGREEMENT - Where Firm has a defined group of persons who might be exposed to harm (e.g. participants in an athletic event/program, volunteers) any waiver or release agreement used by Firm whereby such persons (and their parent/guardian as applicable) discharge Firm from claims and liabilities, shall include the City, its elected officials, departments, officers, officials, employees, and volunteers to the same extent as Firm.

Procurement Guidelines To Implement Minority & Small Business Participation

Underutilized WMBE Primes by Industry Category

FORMAL PROCUREMENT	Construction	Construction-Related	Professional	Non-Professional	Goods
	Black	Asian	Black	Black	Black
	Hispanic	Native Am.	Hispanic	Asian	Hispanic
	Native Am.	Woman	Asian	Native Am.	Asian
	Woman		Native Am.		Native Am.
			Woman		Woman

Underutilized WMBE Sub-Contractors / Sub-Consultants

SUB WORK	Construction	Construction-Related	Professional	Non-Professional	Goods
	Black	Black	Black	Black	Black
		Asian	Hispanic	Asian	Asian
		Native Am.	Asian	Native Am.	Native Am.
		Woman	Native Am.		Woman
			Woman		

Policy

The Guidelines apply to formal procurements and solicitations. WMBE participation will be narrowly-tailored.

Index

- Black = Black/African-American Business Enterprise
- Hispanic = Hispanic Business Enterprise
- Asian = Asian Business Enterprise
- Native Am. = Native American Business Enterprise
- Woman = Woman Business Enterprise (Caucasian)

Industry Categories

Construction is defined as: new construction, renovation, restoration, maintenance of public improvements and underground utilities.

Construction-Related Services are defined as: architecture, professional engineering, landscape architecture, design build, construction management services, or registered surveying and mapping.

Professional Services are defined as: attorney, accountant, medical doctor, veterinarian, miscellaneous consultant, etc.

Non-Professional Services are defined as: lawn maintenance, painting, janitorial, printing, hauling, security guard, etc.

Goods are defined as: all supplies, materials, pipes, equipment, machinery, appliances, and other commodities.

MBD Form-70

**City-wide Meter, Hydrant, and Valve Installation and Replacement
Project #18-C-00030
U-WMBE Availability Contact List**

(The Underutilized WMBE Industry Category for Construction Subcontracts is BBE)

#'s	Business Name	Phone	Fax	Email	Address 1	City	State	Zip	Business Description	FEIN	Cert. Type	Ethnicity
	Manzi Metals, Inc	352-799-8211	352-799-8244	bmanzi@manzimetals	15293 FLIGHT PATH DR	BROOKSVILL	FL	334604	Pipe and Valve Suppl	993245008	BBE	African American
	Suca Pipe Supply, Inc	813-249-7902	813-249-7384	slmau44@yahoo.com	4910 Lowell Rd	Tampa	FL	33624	Pipe and Valve Suppl	992499571	BBE	African American
	Suca Pipe Supply, Inc	813-249-7902	813-249-7384	sucapipesupply1@yahoo	4910 Lowell Road	Tampa	FL	33624	Pipe and Valve Suppl	263669556	BBE	African American
	Terrell Industries, Inc	727-823-4424	727-823-3977	gradyterrell@terrellin	2067 1ST AVENUE NOR	ST PETERSBU	FL	33713	Pipe and Valve Suppl	50530148	BBE	African American
	ECO 2000 INC	352-793-5060	352-793-9074	WATERWORKS@ECO	1611 W C-48	BUSHNELL	FL	33513	Tapping Water Main	993648996	BBE	African American
	McKenzie Contractin	813-454-4429	813-454-4429	kathy@mckenziecontr	7712 E. Broadway Ave.	Tampa	FL	33619	Tapping Water Main	463561860	BBE	African American
	ECO 2000 INC	352-793-5060	352-793-9074	WATERWORKS@ECO	1611 W C-48	BUSHNELL	FL	33513	Jack and Bore Casing	993648996	BBE	African American
	McKenzie Contractin	813-454-4429	813-454-4429	kathy@mckenziecontr	7712 E. Broadway Ave.	Tampa	FL	33619	Jack and Bore Casing	463561860	BBE	African American
	Allen Masonry & Ger	813-597-3289	813-436-0999	allenmasonrygc@gmail	2049 Waikiki Way	Tampa	FL	33619	Concrete Masonry W	993752366	BBE	African American

African American/Black Business Enterprises (BBE) shall count toward the subcontract goal. Refer to MBD Form 70 - Procurement Guidelines

City-wide Meter, Hydrant, and Valve Installation and Replacement

Project #18-C-00030

U-WMBE Availability Contact List

(The Underutilized WMBE Industry Category for Construction Subcontracts is BBE)

#'s	Business Name	Phone	Fax	Email	Address 1	City	State	Zip	Business Description	FEIN	Cert. Type	Ethnicity
	E/S Concrete Service	727-821-5029	727-821-5029	enorisslysr@yahoo.co	726 E. Harbor Drive	St. Petersburg	FL	33705	Concrete Masonry Work	93119582	BBE	African American
	Fresh Start Developm	813-758-5345	813-333-5949	freshstartdevelop@ya	601 S Falkenburg Rd	Tampa	FL	33619	Concrete Masonry Work	203857845	BBE	African American
	Mason Global LLC	813-323-3648	813-323-3648	alan@masongloballc.	6133 Lanshire Dr	Tampa	FL	33634	Concrete Masonry Work	71844251	BBE	African American
	Provisions Constructi	407-985-2442	407-985-2440	marrington@provisio	3401 Lake Breeze Drive	Orlando	FL	32808	Concrete Masonry Work	62802435	BBE	African American
	Allen Masonry & Ger	813-597-3289	813-436-0999	allenmasonrygc@gma	2049 Waikiki Way	Tampa	FL	33619	ConcreteFlat Work	93752366	BBE	African American
	E/S Concrete Service	727-821-5029	727-821-5029	enorisslysr@yahoo.co	726 E. Harbor Drive	St. Petersburg	FL	33705	ConcreteFlat Work	93119582	BBE	African American
	Fresh Start Developm	813-758-5345	813-333-5949	freshstartdevelop@ya	601 S Falkenburg Rd	Tampa	FL	33619	ConcreteFlat Work	203857845	BBE	African American
	Mason Global LLC	813-323-3648	813-323-3648	alan@masongloballc.	6133 Lanshire Dr	Tampa	FL	33634	ConcreteFlat Work	71844251	BBE	African American
	Provisions Constructi	407-985-2442	407-985-2440	marrington@provisio	3401 Lake Breeze Drive	Orlando	FL	32808	ConcreteFlat Work	62802435	BBE	African American

African American/Black Business Enterprises (BBE) shall count toward the subcontract goal. Refer to MBD Form 70 - Procurement Guidelines

**City-wide Meter, Hydrant, and Valve Installation and Replacement
Project #18-C-00030
U-WMBE Availability Contact List**

(The Underutilized WMBE Industry Category for Construction Subcontracts is BBE)

#'s	Business Name	Phone	Fax	Email	Address 1	City	State	Zip	Business Description	FEIN	Cert. Type	Ethnicity
	Denson Construction	863-709-1001	863-709-1071	pete@denson-constru	4270 HOLDEN ROAD	LAKELAND	FL	33811	Concrete Curb	93571944	BBE	African American
	Excel 4 LLC	407-480-8976		excel4llc@yahoo.com	318 N. John Young Park	Kissimmee	FL	34741	Concrete Curb	54149326	BBE	African American
	Exclusive Contractor	863-559-1039	000-000-0000	roadcontractor2@YAH	277 S. 10th Ave	Bartow	FL	33830	Concrete Curb	92345574	BBE	African American
	Excel 4 LLC	407-480-8976		excel4llc@yahoo.com	318 N. John Young Park	Kissimmee	FL	34741	Roadway Restoration	54149326	BBE	African American
	Exclusive Contractor	863-559-1039	000-000-0000	roadcontractor2@YAH	277 S. 10th Ave	Bartow	FL	33830	Roadway Restoration	92345574	BBE	African American
	McKenzie Contractin	813-454-4429	813-454-4429	kathy@mckenziecontri	7712 E. Broadway Ave.	Tampa	FL	33619	Roadway Restoration	63561860	BBE	African American
	AAJ Lawn Care Servig	813-220-8533	888-277-1860	aaajlawncare@gmail.co	3716 E. Idlewild Avenue	Tampa	FL	33610	Landscape and Resto	60254393	BBE	African American
	BAY LIGHT, LLC	813-972-4057	813-971-0882	baylightllc25@gmail.c	10105 N. 11TH ST.	Tampa	FL	33612	Landscape and Resto	55079825	BBE	African American
	BUN Construction Co	813-931-8270	813-931-9185	bunconstruction@tam	4135 E. Hillsborough Av	Tampa	FL	33610	Landscape and Resto	93362663	BBE	African American

African American/Black Business Enterprises (BBE) shall count toward the subcontract goal. Refer to MBD Form 70 - Procurement Guidelines

City-wide Meter, Hydrant, and Valve Installation and Replacement

Project #18-C-00030

U-WMBE Availability Contact List

(The Underutilized WMBE Industry Category for Construction Subcontracts is BBE)

#'s	Business Name	Phone	Fax	Email	Address 1	City	State	Zip	Business Description	FEIN	Cert. Type	Ethnicity
	Cutups Lawn Service	813-361-8871	813-238-2397	cutupslawnservice@yahoo.com	3217 East Powhatan Ave	Tampa	FL	33610	Landscape and Restoration	011241291	BBE	African American
	Dean's Environmental	863-595-8255	904-791-9060	deank8859@gmail.com	2644 Whispering Trails	Winter Haven	FL	33884	Landscape and Restoration	30461047	BBE	African American
	Promise Care LLC	813-988-8633	813-988-1555	promisecarellc@outlook.com	10711 n 53rd st	Tampa	FL	33617	Landscape and Restoration	464723775	BBE	African American
	T.C.C Enterprise Inc	813-606-9148	813-237-0396	tcc_inc@live.com	3902 E POWHATAN AVE	TAMPA	FL	33610	Landscape and Restoration	63223645	BBE	African American
	DeHa Multimedia, LLC	813-340-3017	813-891-0332	hakeem@dehamagazine.com		Dover	FL	33527	Video	260527750	BBE	African American
	Kerrick Williams Photography	813-571-3768	866-571-7149	kerrick@kerrickwilliams.com		Seffner	FL	33584	Video	93225186	BBE	African American
	Denson Construction	863-709-1001	863-709-1071	pete@denson-construction.com	4270 HOLDEN ROAD	LAKELAND	FL	33811	Grout Pumping	93571944	BBE	African American
	Excel 4 LLC	407-480-8976		excel4llc@yahoo.com	318 N. John Young Park	Kissimmee	FL	34741	Grout Pumping	54149326	BBE	African American
	Exclusive Contractors	863-559-1039	000-000-0000	roadcontractor2@yahoo.com	277 S. 10th Ave	Bartow	FL	33830	Grout Pumping	92345574	BBE	African American

African American/Black Business Enterprises (BBE) shall count toward the subcontract goal. Refer to MBD Form 70 - Procurement Guidelines

City-wide Meter, Hydrant, and Valve Installation and Replacement

Project #18-C-00030

U-WMBE Availability Contact List

(The Underutilized WMBE Industry Category for Construction Subcontracts is BBE)

#'s	Business Name	Phone	Fax	Email	Address 1	City	State	Zip	Business Description	FEIN	Cert. Type	Ethnicity
	S&B Technologies Inc	954-675-4547	954-239-9909	Sandy33319@yahoo.com	1830 N. University Dr. #1	Plantation	FL	33322	Signs	63512746	BBE	African American
	BUN Construction Co	813-931-8270	813-931-9185	bunconstruction@tam	4135 E. Hillsborough Av	Tampa	FL	33610	Asphalt Paving	93362663	BBE	African American
	Excel 4 LLC	407-480-8976		excel4llc@yahoo.com	318 N. John Young Park	Kissimmee	FL	34741	Asphalt Paving	54149326	BBE	African American
	Exclusive Contractor	863-559-1039	000-000-0000	roadcontractor2@YAH	277 S. 10th Ave	Bartow	FL	33830	Asphalt Paving	92345574	BBE	African American
	ECO 2000 INC	352-793-5060	352-793-9074	WATERWORKS@ECO	1611 W C-48	BUSHNELL	FL	33513	Line Stopping	93648996	BBE	African American
	McKenzie Contractin	813-454-4429	813-454-4429	kathy@mckenziecontri	7712 E. Broadway Ave.	Tampa	FL	33619	Line Stopping	63561860	BBE	African American
	Allen Masonry & Ger	813-597-3289	813-436-0999	allenmasonrygc@gma	2049 Waikiki Way	Tampa	FL	33619	Brick Paving	93752366	BBE	African American
	E/S Concrete Service	727-821-5029	727-821-5029	enorisslysr@yahoo.co	726 E. Harbor Drive	St. Petersburg	FL	33705	Brick Paving	93119582	BBE	African American
	Fresh Start Developm	813-758-5345	813-333-5949	freshstartdevelop@ya	601 S Falkenburg Rd	Tampa	FL	33619	Brick Paving	03857845	BBE	African American

African American/Black Business Enterprises (BBE) shall count toward the subcontract goal. Refer to MBD Form 70 - Procurement Guidelines

City-wide Meter, Hydrant, and Valve Installation and Replacement

Project #18-C-00030

U-WMBE Availability Contact List

(The Underutilized WMBE Industry Category for Construction Subcontracts is BBE)

#'s	Business Name	Phone	Fax	Email	Address 1	City	State	Zip	Business Description	FEIN	Cert. Type	Ethnicity
	Mason Global LLC	813-323-3648	813-323-3648	alan@masongloballc.com	6133 Lanshire Dr	Tampa	FL	33634	Brick Paving	471844251	BBE	African American
	Provisions Constructi	407-985-2442	407-985-2440	marrington@provision	3401 Lake Breeze Drive	Orlando	FL	32808	Brick Paving	462802435	BBE	African American

Instructions Regarding Use of the WMBE/SLBE Availability Contact List

Bidders must solicit a subcontracting bid from ALL of the firms listed on the WMBE/SLBEs list provided within the Specifications, and provide documentation of emails, faxes, phone calls, letters, or other communication with the firms as a first step in demonstrating Good-Faith Efforts to achieve the goal set for WMBE/SLBE participation on this contract.

The list is formatted to facilitate e-mailing of a solicitation to the listed firms by copying and pasting the email addresses.

The WMBE/SLBE participation Goal is based upon the availability of the certified firms indicated on the contact list. The Goal and Requirements of the City's Equal Business Opportunity Program are stated in the Bid/Contract Document, Specifications.

SOLICITATION FOR SUBCONTRACTOR QUOTES

From:
OUR COMPANY NAME:
TELEPHONE NUMBER:
ADDRESS:
FAX NUMBER:
E-MAIL ADDRESS:

To Subcontractor:

Our firm is in the process of preparing a bid for a **City of Tampa Contract**. Please accept this notice as our request for quotes for the scope of work identified below. Please respond to this request by filling in the information below and returning via e-mail or fax to the address or number provided. Please contact us if you need any assistance in obtaining bonding, lines of credit, insurance, assistance in obtaining necessary equipment, supplies, materials, participation in a City-sponsored mentor-protégé program, or if you have any questions.

Plans and Specs for this project are posted at:
<http://www.tampagov.net/contract-administration/programs/construction-project-bidding>

CONTRACT NO.:
CONTRACT NAME:
CITY'S BID OPENING DATE:
DEADLINE FOR YOUR SUBCONTRACTOR BID OR RESPONSE:
SPECIFIC SCOPE OF WORK:

Please complete and submit with your subcontract bid or response:

YOUR FIRM'S NAME:
MAILING ADDRESS:
CITY:
STATE:
ZIP:
FAX NUMBER:
E-MAIL ADDRESS:

Yes, my company is interested in quoting this project for the following items of work:

No, my company will not quote this project for the following reason(s):

(Sample Suggested Sub Solicitation 3-9-9 Tampa MBDO)

PROPOSAL

To the Mayor and City Council of the City of Tampa, Florida:

Legal Name of Bidder: _____

Bidder's Fictitious Name, *if applicable*: _____

Bidder is a/an: Individual Partnership* Joint Venture* LLC Corp. Other:

Bidder is organized under the laws of: State of Florida Other:

Bidder Mailing Address: _____

Bidder's Federal Employee Identification No. (FEI/EIN): _____

Bidder's License No.: _____ Bidder's FDOS (SUNBIZ) Doc. No.: _____
(See Ch. 489, FS; use entity's, individual's only if applicable)

Bidder Contact Name**: _____ Email: _____ Phone: (____) _____

Bidder's own initial application for employment has criminal history screening practices similar in nature to the practices contained in Chapter 12, Article VI, City of Tampa Code (*Responses, whether "Yes" or "No", are for informational purposes only and will not be used as a basis of award or denial, nor as a basis for any protest*): Yes No

The below named person, appearing before the undersigned authority and after being first duly sworn, for him/herself and on behalf of the entity submitting this Proposal does hereby affirm and declare as follows:

- (1) He/She is of lawful age and is authorized to act on behalf of Bidder (the individual, partnership, corporation, entity, etc. submitting this Proposal) and that all statements made in this document are true and correct to the best of my knowledge.
- (2) If Bidder is operating under a fictitious name, Bidder has currently complied with any and all laws and procedures governing the operation of businesses under fictitious names in the State of Florida
- (3) No person or entity other than Bidder has any interest in this Proposal or in the Contract proposed to be entered into.
- (4) This Proposal is made without any understanding, agreement, or connection with any person or entity making Proposal for the same purposes, and is in all respects fair and without collusion or fraud.
- (5) Bidder is not in arrears to the City of Tampa, upon debt or contract, and is not a defaulter, as surety or otherwise, upon any obligation to the City of Tampa.
- (6) That no officer or employee or person whose salary is payable in whole or in part from the City Treasury is, shall be or become interested, directly or indirectly, as a contracting party, partner, stockholder, surety or otherwise, in this Proposal, or in the performance of the Contract, or in the supplies, materials, or equipment and work or labor to which it relates, or in any portion of the profits thereof.
- (7) Bidder has carefully examined and fully understands the Solicitation and has full knowledge of the scope, nature, and quality of the work to be performed; furthermore, Bidder has carefully examined the site of the work and that, from his own investigations, he has satisfied himself as to the nature and location of the work, the character, quality, and quantity of materials and the kinds and extent of equipment and other facilities needed for the performance of the work, the general and local conditions and all difficulties to be encountered, and all other items which may, in any way, affect the work or its performance.
- (8) Bidder (including its principals) has | has NOT been debarred or suspended from contracting with a public entity.
- (9) Bidder has | has NOT implemented a drug-free workplace program that meets the requirements of Section 287.087, Florida Statutes.
- (10) Bidder has carefully examined and fully understands all the component parts of the Contract Documents and agrees Bidder will execute the Contract, provide the required Public Construction Bond, and will fully perform the work in strict accordance with the terms of the Contract and Contract Documents therein referred to for the following prices, to wit:

* If a Partnership or Joint Venture, attach Partnership or Joint Venture Agreement.

** Someone the City may contact with questions/correspondence regarding this Solicitation and/or permits.

Item No. Description Unit Approx. Quantity Unit Price in Words Unit Price Total Computed Price

ENGINEER'S ESTIMATE						
Item No.	Description	Unit	Approx. Quantity	Unit Price in Words	Unit Price	Total Computed Price
2100	F&I 4" ductile iron pipe	LF	200	\$	\$	\$
2102	F&I 6" ductile iron pipe	LF	200	\$	\$	\$
2104	F&I 8" ductile iron pipe	LF	200	\$	\$	\$
2105	F&I 10" ductile iron pipe	LF	200	\$	\$	\$
2106	F&I 12" ductile iron pipe	LF	200	\$	\$	\$
2108	F&I 16" ductile iron pipe	LF	200	\$	\$	\$
2149	F&I 2" PVC pipe and fittings at various depths	LF	100	\$	\$	\$
2150	F&I 4" PVC pipe	LF	100	\$	\$	\$
2152	F&I 6" PVC pipe	LF	100	\$	\$	\$
2154	F&I 8" PVC pipe	LF	100	\$	\$	\$
2156	F&I 12" PVC pipe	LF	100	\$	\$	\$
2158	F&I 16" PVC pipe	LF	100	\$	\$	\$
2160	F&I 4" restrained joint PVC pipe by open cut	LF	100	\$	\$	\$
2162	F&I 6" restrained joint PVC pipe by open cut	LF	100	\$	\$	\$
2164	F&I 8" restrained joint PVC pipe by open cut	LF	100	\$	\$	\$
2166	F&I 12" restrained joint PVC pipe by open cut	LF	100	\$	\$	\$
2168	F&I 16" restrained joint PVC pipe by open cut	LF	100	\$	\$	\$
2200	F&I 2" HDPE w/HDPE transitions adapters at various depths	LF	100	\$	\$	\$

Item No. Description Unit Approx. Quantity Unit Price in Words Unit Price Total Computed Price

2201	F&I 4" HDPE pipe at variuos depths	LF	100		\$	\$
2202	F&I 6" HDPE pipe at variuos depths	LF	100		\$	\$
2203	F&I 8" HDPE pipe at variuos depths	LF	100		\$	\$
2204	F&I 10" HDPE pipe at variuos depths	LF	100		\$	\$
2205	F&I 12" HDPE pipe at variuos depths	LF	100		\$	\$
2206	F&I 14" HDPE pipe at variuos depths	LF	100		\$	\$
2207	F&I 6" restrained joint PVC pipe by HDD at various depths	LF	100		\$	\$
2208	F&I 8" restrained joint PVC pipe by HDD at various depths	LF	100		\$	\$
2212	F&I 12" restrained joint PVC pipe by HDD at various depths	LF	100		\$	\$
2216	F&I 16" restrained joint PVC pipe by HDD at various depths	LF	100		\$	\$
2300	Furnish, install and remove 2-inch temporary service line	LF	50		\$	\$
2400	Furnish & install 4" OD steel casing pipe	LF	2		\$	\$
2401	Furnish & install 12" OD steel casing pipe	LF	2		\$	\$
2402	Furnish & install 14" OD steel casing pipe	LF	2		\$	\$
2403	Furnish & install 16" OD steel casing pipe	LF	2		\$	\$
2404	Furnish & install 20" OD steel casing pipe	LF	2		\$	\$
2405	Furnish & install 24" OD steel casing pipe	LF	2		\$	\$
2500	Removal of abandoned pipe 3" and smaller in diameter	LF	2		\$	\$
2501	Removal of abandoned pipe 4" - 10" in diameter	LF	2		\$	\$

Item No. Description Unit Approx. Quantity Unit Price in Words Unit Price Total Computed Price

2502	Removal of abandoned pipe 12" and larger in diameter	LF	2		\$	
2600	Cut and plug 3" and smaller in diameter pipe, to include meter services lines	EA	10		\$	
2601	Cut and plug 4", 6" and 8" diameter pipe	EA	2		\$	
2602	Cut and plug 10", 12" and 16" diameter pipe	EA	2		\$	
2700	Furnish and push 4" ductile iron pipe under root system	LF	10		\$	
2701	Furnish and push 6" ductile iron pipe under root system	LF	10		\$	
2702	Furnish and push 8" ductile iron pipe under root system	LF	10		\$	
2800	Make tap and furnish materials to connect 3" and smaller water mains to new/existing mains (0-15 ft. in length)	EA	2		\$	
2801	Make tap and furnish materials to connect 3" and smaller water mains to new/existing mains (more than 15 ft. in length)	EA	2		\$	
3000	F&I 4" wedge-action MJ or flange restraint	EA	10		\$	
3001	F&I 6" wedge-action MJ or flange restraint	EA	10		\$	
3002	F&I 8" wedge-action MJ or flange restraint	EA	10		\$	
3003	F&I 10" wedge-action MJ or flange restraint	EA	10		\$	
3004	F&I 12" wedge-action MJ or flange restraint	EA	10		\$	
3005	F&I 14" wedge-action MJ or flange restraint	EA	10		\$	
3006	F&I 16" wedge-action MJ or flange restraint	EA	10		\$	
3040	Furnish & install 4" bell and MJ restraint on existing pipe	EA	4		\$	
3041	Furnish & install 6" bell and MJ restraint on existing pipe	EA	4		\$	
3042	Furnish & install 8" bell and MJ restraint on existing pipe	EA	4		\$	

Item No. Description Unit Approx. Quantity Unit Price in Words Unit Price Total Computed Price

3043	Furnish & install 10" bell and MJ restraint on existing pipe	EA	4		\$	\$
3044	Furnish & install 12" bell and MJ restraint on existing pipe	EA	4		\$	\$
3045	Furnish & install 16" bell and MJ restraint on existing pipe	EA	4		\$	\$
3050	Furnish & install 4" wedge-action MJ restraint on new PVC pipe	EA	10		\$	\$
3051	Furnish & install 6" wedge-action MJ restraint on new PVC pipe	EA	10		\$	\$
3052	Furnish & install 8" wedge-action MJ restraint on new PVC pipe	EA	10		\$	\$
3053	Furnish & install 12" wedge-action MJ restraint on new PVC pipe	EA	10		\$	\$
3054	Furnish & install 16" wedge-action MJ restraint on new PVC pipe	EA	10		\$	\$
3070	Furnish 4" push-on gasket (gripper-type) restraint	EA	2		\$	\$
3071	Furnish 6" push-on gasket (gripper-type) restraint	EA	2		\$	\$
3072	Furnish 8" push-on gasket (gripper-type) restraint	EA	2		\$	\$
3073	Furnish 12" push-on gasket (gripper-type) restraint	EA	2		\$	\$
3074	Furnish 16" push-on gasket (gripper-type) restraint	EA	2		\$	\$
4000	F&I 4" DI MJ plug or cap	EA	2		\$	\$
4001	F&I 4" DI MJ bend, offset, sleeve or reducer	EA	2		\$	\$
4002	F&I 4" DI MJ tee	EA	2		\$	\$
4003	F&I 4" (x 12") DI MJ offset	EA	2		\$	\$
4004	F&I 6" DI MJ plug or cap	EA	2		\$	\$
4005	F&I 6" DI MJ bend, offset, sleeve or reducer	EA	2		\$	\$

Item No. Description Unit Approx. Quantity Unit Price in Words Unit Price Total Computed Price

4006	F&I 6" DI MJ tee	EA	2		\$	\$
4007	F&I 6" (x 12") DI MJ offset	EA	2		\$	\$
4008	F&I 8" DI MJ plug or cap	EA	2		\$	\$
4009	F&I 8" DI MJ bend, offset, sleeve or reducer	EA	2		\$	\$
4010.1	F&I 8" x 4" DI MJ tee	EA	2		\$	\$
4010.2	F&I 8" x 6" DI MJ tee	EA	2		\$	\$
4010.3	F&I 8" x 8" DI MJ tee	EA	2		\$	\$
4011	F&I 8" (x 12") DI MJ offset	EA	2		\$	\$
4012	F&I 12" D MJ plug or cap	EA	2		\$	\$
4013	F&I 12" DI MJ sleeve or reducer	EA	2		\$	\$
4013.1	F&I 12" DI MJ 11.25° (or 22.5°) bend	EA	2		\$	\$
4013.2	F&I 12" 45° DI MJ bend	EA	2		\$	\$
4013.3	F&I 12" 90° DI MJ bend	EA	2		\$	\$
4014.1	F&I 12" x 4" (or 6") DI MJ tee	EA	2		\$	\$
4014.2	F&I 12" x 8" DI MJ tee with	EA	2		\$	\$
4014.3	F&I 12" x 12" DI MJ tee	EA	2		\$	\$
4015	F&I 12" (x 12") DI MJ offset	EA	2		\$	\$
4016	F&I 16" MJ DI MJ plug or cap	EA	2		\$	\$
4017	F&I 16" DI MJ sleeve or reducer	EA	2		\$	\$

Item No. Description Unit Approx. Quantity Unit Price in Words Unit Price Total Computed Price

4017.1	F&I 16" DI MJ 11.25° bend	EA	2		\$	\$
4017.2	F&I 16" 22.5° DI MJ bend	EA	2		\$	\$
4017.3	F&I 16" 45° DI MJ bend	EA	2		\$	\$
4017.4	F&I 16" 90° DI MJ bend	EA	2		\$	\$
4018.1	F&I 16" x 4" (or 6") DI MJ tee	EA	2		\$	\$
4018.2	F&I 16" x 8" DI MJ tee	EA	2		\$	\$
4018.3	F&I 16" x 12" DI MJ tee	EA	2		\$	\$
4018.4	F&I 16" x 16" DI MJ tee	EA	2		\$	\$
4019	F&I 16" (x 12") DI MJ offset	EA	2		\$	\$
5000	F&I Full FHA on new or existing main – via Tee or Tap (valve and tee/tap paid separate)	EA	2		\$	\$
5001	F&I Full FHA on ex. main – via Remove & Replace ex. hydrant, valve & tee (new valve and tee paid separate)	EA	2		\$	\$
5002	F&I FHA and Valve on ex. main – via Remove & Replace ex. hydrant and hydrant valve (new valve to be paid separate)	EA	2		\$	\$
5003	F&I FHA and Valve on ex. main – via Remove & Replace ex. FHA & waste ex. valve (new valve paid separate)	EA	2		\$	\$
5004	Remove and Relocate ex. FHA and/or valve downstream of ex. hydrant valve or tee	EA	2		\$	\$
5010	F&I 6" Gradelok fitting with 5001, 5002, or 5003 installations	EA	2		\$	\$
5011	F&I 12" Gradelok fitting with 5001, 5002, or 5003 installations	EA	2		\$	\$
5012	F&I 24" Gradelok fitting with 5001, 5002, or 5003 installations	EA	2		\$	\$
5101	Remove & salvage hydrant - Type I removal	EA	2		\$	\$
5102	Remove & salvage hydrant - Type II removal	EA	2		\$	\$

Item No. Description Unit Approx. Quantity Unit Price in Words Unit Price Total Computed Price

5300	F&I Protection Post	EA	2		\$	\$
6000	F&I 2" gate or tapping valve (wow) with box on new main	EA	2		\$	\$
6001	F&I 4" gate or tapping valve (wow) with box on new main	EA	2		\$	\$
6002	F&I 6" gate or tapping valve (wow) with box on new main	EA	2		\$	\$
6003	F&I 8" gate or tapping valve (wow) with box on new main	EA	2		\$	\$
6004	F&I 10" gate or tapping valve (wow) with box on new main	EA	2		\$	\$
6005	F&I 12" gate or tapping valve (wow) with box on new main	EA	2		\$	\$
6006	F&I 16" gate valve (wow) with box on new main	EA	2		\$	\$
6020	F&I 16" butterfly valve (wow) with box on new main	EA	2		\$	\$
6080	F&I 2-ft. Valve Nut Extension	EA	2		\$	\$
6081	F&I 3-ft. Valve Nut Extension	EA	2		\$	\$
6082	F&I 4-ft. Valve Nut Extension	EA	2		\$	\$
6100	F&I 2" gate valve and box on existing main	EA	2		\$	\$
6101	F&I 3" gate valve and box on existing main	EA	2		\$	\$
6102	F&I 4" gate valve and box on existing main	EA	2		\$	\$
6103	F&I 6" gate valve and box on existing main	EA	2		\$	\$
6104	F&I 8" gate valve and box on existing main	EA	2		\$	\$
6105	F&I 10" gate valve and box on existing main	EA	2		\$	\$
6106	F&I 12" gate valve and box on existing main	EA	2		\$	\$

Item No. Description Unit Approx. Quantity Unit Price in Words Unit Price Total Computed Price

6107	F&I 16" gate valve and box on existing main	EA	2		\$	
6115	F&I 16" butterfly valve and box on existing main	EA	2		\$	
6130	F&I 16" gate valve and box on existing DIP or CIP, in ex. Vault	EA	2		\$	
6131	F&I 16" butterfly valve and box on existing DIP or CIP, in ex. Vault	EA	2		\$	
6140	Remove ≥16" valve from ex. vault, sleeve pipe ends together, backfill vault, dispose of ex. lid	EA	2		\$	
6200	F&I 2" or 2-1/2" Linestop on Water Main	EA	1		\$	
6201	F&I 4" Linestop on DI/CI/PVC Water Main	EA	1		\$	
6202	F&I 4" Linestop on AC Water Main	EA	1		\$	
6203	F&I 6" Linestop on DI/CI/PVC Water Main	EA	1		\$	
6204	F&I 6" Linestop on AC Water Main	EA	1		\$	
6205	F&I 8" Linestop on DI/CI/PVC Water Main	EA	1		\$	
6206	F&I 8" Linestop on AC Water Main	EA	1		\$	
6207	F&I 10" Linestop on DI/CI/PVC Water Main	EA	1		\$	
6208	F&I 12" Linestop on DI/CI/PVC Water Main	EA	1		\$	
6209	F&I 16" Linestop on DI/CI/PVC Water Main	EA	1		\$	
6210	F&I 24" Linestop on DI/CI Water Main	EA	1		\$	
6211	F&I 30" Linestop on DI/CI Water Main	EA	1		\$	
6212	F&I 36" Linestop on DI/CI Water Main	EA	1		\$	
6304	F&I 4" TEAM Insertion Valve	EA	1		\$	

Item No. Description Unit Approx. Quantity Unit Price in Words Unit Price Total Computed Price

Item No.	Description	Unit	Approx. Quantity	Unit Price in Words	Unit Price	Total Computed Price
6306	F&I 6" TEAM Insertion Valve	EA	1		\$	\$
6308	F&I 8" TEAM Insertion Valve	EA	1		\$	\$
6312	F&I 12" TEAM Insertion Valve	EA	1		\$	\$
7001.0	F&I 4" MJ tapping sleeve and make tap	EA	1		\$	\$
7000.1	F&I 6" x 4" Steel tapping sleeve and make tap	EA	1		\$	\$
7001.2	F&I 6" x 6" MJ tapping sleeve and make tap	EA	1		\$	\$
7002.1	F&I 8" x 4" Steel tapping sleeve and make tap	EA	1		\$	\$
7002.2	F&I 8" x 6" Steel tapping sleeve and make tap	EA	1		\$	\$
7002.3	F&I 8" x 8" MJ tapping sleeve and make tap	EA	1		\$	\$
7003.1	F&I 12" x 4" Steel tapping sleeve and make tap	EA	1		\$	\$
7003.2	F&I 12" x 6" Steel tapping sleeve and make tap	EA	1		\$	\$
7003.3	F&I 12" x 8" Steel tapping sleeve and make tap	EA	1		\$	\$
7003.4	F&I 12" x 12" MJ tapping sleeve and make tap	EA	1		\$	\$
7004.1	F&I 16" x (≤8") Steel tapping sleeve and make tap	EA	1		\$	\$
7004.2	F&I 16" x 12" Steel tapping sleeve and make tap	EA	1		\$	\$
7004.3	F&I 16" x 16" MJ tapping sleeve and make tap	EA	1		\$	\$
8100	FT&I 3/4" or 1" meter service on PVC/P, DIP, or CIP (0-15')	EA	160		\$	\$
8101	FT&I 3/4" meter service on PVC/P, DIP or CIP (+15-80')	EA	160		\$	\$
8102	FT&I 3/4" meter service on PVC/P, DIP or CIP (+80-150')	EA.	1		\$	\$

Item No. Description Unit Approx. Quantity Unit Price in Words Unit Price Total Computed Price

8103	FT&I 3/4" or 1" Dual meter service on PVCp, DIP or CIP (0 - 15')	EA.	1		\$	\$
8104	FT&I 3/4" or 1" Dual meter service on PVCp, DIP or CIP (+15'-80')	EA.	1		\$	\$
8105	FT&I 3/4" Dual meter service on PVCp, DIP or CIP (+80'-150')	EA.	1		\$	\$
8106	FT&I 1" Dual meter service on PVCp, DIP or CIP (+80'-150')	EA.	1		\$	\$
8107	FT&I 1" or 1-1/2" meter service on PVCp, DIP or CIP (+15'-80')	EA	1		\$	\$
8108	FT&I 1" or 1-1/2" meter service on PVCp, DIP or CIP (+80'-150')	EA	1		\$	\$
8109	FT&I 1-1/2" or 2" meter service on PVCp, DIP or CIP (0-15')	EA	1		\$	\$
8110	FT&I 2" DDCV and service on PVCp, DIP or CIP (0-15')	EA	1		\$	\$
8120	FT&I 3/4" or 1" meter service on HDPEP (0-15')	EA	1		\$	\$
8121	FT&I 3/4" meter service on HDPEP (+15-80')	EA	1		\$	\$
8122	FT&I 3/4" meter service on HDPEP (+80-150')	EA	1		\$	\$
8123	FT&I 3/4" or 1" Dual meter service on HDPEP (0 - 15')	EA	1		\$	\$
8124	FT&I 3/4" or 1" Dual meter service on HDPEP (+15-80')	EA.	1		\$	\$
8125	FT&I 3/4" Dual meter service on HDPEP (+80'-150')	EA.	1		\$	\$
8126	FT&I 1" Dual meter service on HDPEP (80'-150')	EA.	1		\$	\$
8127	FT&I 1" or 1-1/2" meter service on HDPEP (+15'-80')	EA	1		\$	\$
8128	FT&I 1" or 1-1/2" meter service on HDPEP (+80'-150')	EA	1		\$	\$
8129	FT&I 1-1/2" or 2" meter service on HDPEP (0-15')	EA	1		\$	\$
8130	FT&I 2" DDCV and service on HDPEP (0-15')	EA	1		\$	\$

Item No. Description Unit Approx. Quantity Unit Price in Words Unit Price Total Computed Price

Item No.	Description	Unit	Approx. Quantity	Unit Price in Words	Unit Price	Total Computed Price
8300	Install city-provided 3" meter (slab or vault to be paid separate)	EA	1		\$	\$
8301	Install city-provided 4" meter (slab or vault to be paid separate)	EA	1		\$	\$
8302	Install city-provided 6" meter (slab or vault to be paid separate)	EA	1		\$	\$
8303	Install city-provided 8" meter (slab or vault to be paid separate)	EA	1		\$	\$
8320	Install 4" double detector check valve assembly	EA	1		\$	\$
8321	Install 6" double detector check valve assembly	EA	1		\$	\$
8322	Install 8" double detector check valve assembly	EA	1		\$	\$
8323	Install 10" double detector check valve assembly	EA	1		\$	\$
8324	Install 12" double detector check valve assembly	EA	1		\$	\$
8400	F&I 6' 0" X 6' 0" above-ground vault or below-ground vault	EA	1		\$	\$
8401	F&I 8' 0" X 5' 4" above-ground vault or below-ground vault	EA	1		\$	\$
8402	F&I 9' 4" X 8' 0" above-ground vault or below-ground vault	EA	1		\$	\$
8403	F&I 10' 8" X 8' 0" above-ground vault or below-ground vault	EA	1		\$	\$
8404	F&I auxiliary materials for above-ground large service w/ 12'x5' slab	EA	1		\$	\$
8405	F&I auxiliary materials for above-ground large service w/ 12'x9' slab	EA	1		\$	\$
9200	(RFS) Furnish, place and compact limerock base	CY	40		\$	\$
9201	(RFS) Furnish, place and compact crushed concrete base	CY	40		\$	\$
9202	(RFS) Furnish and place approved flowable fill	CY	10		\$	\$
9203	(RFS) Furnish, place and compact asphalt base course (Superpave Type B-12.5)	SY-IN	60		\$	\$

Item No. Description Unit Approx. Quantity Unit Price in Words Unit Price Total Computed Price

9204	(RFS) Furnish and install asphalt concrete surface course (Type S-1)	SY-IN	60		\$	\$
9205	(RFS) Furnish, place and compact asphalt concrete surface course, (Superpave Type SP-12.5)	SY-IN	60		\$	\$
9206	(RFS) Furnish, place, grade and compact asphaltic concrete overlay (Type SIII)	SY-IN	60		\$	\$
9207	(RFS) Furnish, place, grade and compact asphaltic concrete overlay (Superpave Type SP-9.5)	SY-IN	60		\$	\$
9208	(RFS) Mobilization to perform mechanical milling	EA	4		\$	\$
9209	(RFS) Mechanical milling of asphalt roadways in 1-inch increments	SY-IN	1,000		\$	\$
9210	(RFS) Restore 6" thick concrete driveway	SY	60		\$	\$
9211	(RFS) Restore brick pavement, including base material	SY	10		\$	\$
9212	(RFS) Install Brick pavement furnished by City, Contractor F&I base material	SY	10		\$	\$
9220	(RFO) Furnish, place and compact limerock base	CY	40		\$	\$
9221	(RFO) Furnish, place and compact crushed concrete base	CY	40		\$	\$
9222	(RFO) Furnish and place approved flowable fill	CY	10		\$	\$
9223	(RFO) Furnish, place and compact asphalt base course (Superpave Type B-12.5)	SY-IN	60		\$	\$
9224	(RFO) Furnish and install asphalt concrete surface course (Type S-1)	SY-IN	60		\$	\$
9225	(RFO) Furnish, place and compact asphalt concrete surface course, (Superpave Type SP-12.5)	SY-IN	60		\$	\$
9226	(RFO) Furnish, place, grade and compact asphaltic concrete overlay (Type SIII)	SY-IN	60		\$	\$
9227	(RFO) Furnish, place, grade and compact asphaltic concrete overlay (Superpave Type SP-9.5)	SY-IN	60		\$	\$
9228	(RFO) Mobilization to perform mechanical milling	EA	5		\$	\$
9229	(RFO) Mechanical milling of asphalt roadways in 1-inch increments	SY-IN	1,000		\$	\$

Item No. Description Unit Approx. Quantity Unit Price in Words Unit Price Total Computed Price

9230	(RFO) Restore 6" thick concrete driveway	SY	60		\$	\$
9231	(RFO) Restore brick pavement, including base material	SY	20		\$	\$
9232	(RFO) Install Brick pavement furnished by City, Contractor F&I base material	SY	20		\$	\$
9250	Furnish materials & Install Signalization loops	EA	2		\$	\$
9251	Furnish Traffic Control Officer (Off-Duty Law Enforcement)	MH	10		\$	\$
9252	Furnish and install Work Zone Signs	ED	200		\$	\$
9253	Furnish and install Business Signs	ED	10		\$	\$
9254	Furnish and install Barricades (Temporary – Type II)	ED	1,000		\$	\$
9255	Furnish and install Barricades (Temporary Type III) (6")	ED	1,000		\$	\$
9256	Furnish and install Advance Warning Arrow Panel	ED	10		\$	\$
9257	Furnish and install High Intensity Flashing Lights (Temporary-Type B)	ED	1,000		\$	\$
9258	Furnish and install Variable Message Sign (Temporary)	ED	10		\$	\$
9259	Prepare and submit agency specific S&S MOT plans, if required	SH	10		\$	\$
9300	(RFS) Furnish and install Type "D" concrete curb	LF	20		\$	\$
9301	(RFS) Furnish and install valley curb	LF	20		\$	\$
9302	(RFS) Furnish and install Miami curb	LF	10		\$	\$
9303	(RFS) Furnish and install Type "F" concrete curb	LF	10		\$	\$
9304	(RFS) Furnish and install stone or precast curb	LF	20		\$	\$
9305	(RFS) Remove and install existing stone curb	LF	10		\$	\$

Item No. Description Unit Approx. Quantity Unit Price in Words Unit Price Total Computed Price

9306	(RFS) Furnish and install asphaltic concrete curb	LF	10		\$	\$
9307	(RFS) Furnish and install 4" thick concrete sidewalk	SY	60		\$	\$
9308	(RFS) Furnish and install hexagon block sidewalk	SY	10		\$	\$
9309	(RFS) Grade and sod roadside/ditch bottoms and sides - Bahia	SY	500		\$	\$
9310	(RFS) Grade and sod roadside/ditch bottoms & sides - St. Augustine	SY	300		\$	\$
9311	(RFS) Grade, fertilize, sprig, and hydro-seed roadside	SY	20		\$	\$
9312	(RFS) F&I detectable warnings on concrete walking surfaces	EA	6		\$	\$
9320	(RFO) Furnish and install Type "D" concrete curb	LF	20		\$	\$
9321	(RFO) Furnish and install valley curb	LF	20		\$	\$
9322	(RFO) Furnish and install Miami curb	LF	20		\$	\$
9323	(RFO) Furnish and install Type "F" concrete curb	LF	20		\$	\$
9324	(RFO) Furnish and install stone or precast curb	LF	20		\$	\$
9325	(RFO) Remove and install existing stone curb	LF	20		\$	\$
9326	(RFO) Furnish and install asphaltic concrete curb	LF	20		\$	\$
9327	(RFO) Furnish and install 4" thick concrete sidewalk	SY	50		\$	\$
9328	(RFO) Furnish and install hexagon block sidewalk	SY	3		\$	\$
9329	(RFO) Grade and sod roadside/ditch bottoms and sides - Bahia	SY	200		\$	\$
9330	(RFO) Grade and sod roadside/ditch bottoms & sides - St. Augustine	SY	200		\$	\$
9331	(RFO) Grade, fertilize, sprig, and hydro-seed roadside	SY	2		\$	\$

Item No. Description Unit Approx. Quantity Unit Price in Words Unit Price Total Computed Price

9332	(RFO) F&I detectable warnings on concrete walking surfaces	EA	2		\$	
9400	Grout abandoned pipe	CY	2		\$	
9410	Place and compact backfill soils	CY	2		\$	
9411	Furnish, place and compact backfill soils	CY	2		\$	
9500	Furnish, form and place reinforced concrete	CY	2		\$	
9501	Restore rip-rap (rubble)	CY	2		\$	
9502	Replace 4" or 6" VC sanitary sewer pipe with PVC	LF	2		\$	
9503	Replace 8" or 10" VC sanitary sewer pipe with PVC	LF	2		\$	
9504	Replace damaged but not marked sanitary laterals, w PVC	LF	2		\$	
9505	Video photography	LF	100		\$	
9600	Demolish and Remove Large service vault	EA	1		\$	
9601	Demolish and Remove Large service concrete slab	EA	1		\$	
9700	Excavation and removal of rock	CY	6		\$	
9701	Excavation and removal of muck	CY	6		\$	
9800	Removal of trees 5" in diameter and greater	EA	1		\$	
9801	Root Pruning	LF	1		\$	
9802	F&I 2" diameter Oaks	EA	1		\$	
9900	Excavation exploratory pits	EA	1	Five Hundred Dollars & No Cents	\$	500.00
9920	F&I blow-off assembly w/valve & meter box, per Detail 2.16	EA	1		\$	

Item No.	Description	Unit	Approx. Quantity	Unit Price in Words	Unit Price	Total Computed Price
9921	F&I blow-off assembly w/valve & meter box, per Detail 2.17	EA	1		\$	\$
9922	F&I air release valve (ARV) w/pedestal per Detail 2.14	EA	1		\$	\$
9923	F&I air vacuum air release valve (AVAR) w/pedestal, per Detail 2.14C	EA	1		\$	\$
9930	Furnish & install precast thrust blocks	EA	1		\$	\$
9931	Furnish, form & pour concrete thrust blocks	CY	1		\$	\$
9940	Cut into existing asbestos concrete pipe	EA	1		\$	\$
9950	F&I new project sign	EA	1		\$	\$
9951	Furnish & install and previously used (and relettered) project sign	EA	1		\$	\$
9980	Contingency allowance - to be used by City	LS	1	One Hundred Eighty Five Thousand Dollars & no cents	\$	185,000.00
10000	Payment and Performance Bond Allowance	LS	1	Thirty Thousand Dollars and No Cents	\$	30,000.00
				TOTAL		

Contract 18-C-00030; City-wide Meter, Hydrant, Valve Installation and Replacement

Computed Total Price in Words: _____
 _____ dollars and _____ cents.

Computed Total Price in Figures: \$ _____

Bidder acknowledges that the following addenda have been received and that the changes covered by the addendum(s) have been taken into account in this proposal: #1 ____ #2 ____ #3 ____ #4 ____ #5 ____ #6 ____ #7 ____ #8 ____.

Bidder acknowledges the requirements of the City of Tampa's Equal Business Opportunity Program.

Bidder acknowledges that it is aware of Florida's Trench Safety Act (Sections 553.60-553.64, Florida Statutes), and agrees that Bidder together with any involved subcontractors will comply with all applicable trench safety standards. Bidder further acknowledges that included in the various items of this Proposal and the total bid price (as applicable) are costs for complying with the Trench Safety Act. Bidder further identifies the costs and methods summarized below:

	Trench Safety Measure (Description)	Unit of Measure (LF, SY)	Unit Quantity	Unit Cost	Extended Cost
A.	_____	_____	_____	_____	_____
B.	_____	_____	_____	_____	_____
C.	_____	_____	_____	_____	_____
Total Cost: \$				_____	

Accompanying this Proposal is a certified check, cashier's check or Tampa Bid Bond (form included herein must be used) for at least five percent (5%) of the total amount of the Proposal which check shall become the property of the City, or which bond shall become forthwith due and payable to the City, if this Proposal shall be accepted by the City and the Bidder shall fail to enter into a legally binding contract with and to furnish the required Public Construction Bond to the City within twenty (20) days after the date of its receipt of written Notice of Award by the City so to do.

FAILURE TO COMPLETE THE ABOVE MAY RESULT IN THE PROPOSAL BEING DECLARED NON-RESPONSIVE.

[SEAL]

Name of Bidder: _____

Authorized Signature: _____

Signer's Printed Name: _____

Signer's Title: _____

STATE OF _____

COUNTY OF _____

For an entity: The forgoing instrument was sworn (or affirmed) before me this ____ day of _____, 20____ by _____ as _____ of _____, a/n Partnership Joint Venture LLC Corp Other: _____, on behalf of such entity. Such individual is personally known to me or produced a/n _____ state driver's license as identification.

For an individual: The forgoing instrument was sworn (or affirmed) before me this ____ day of _____, 20____ by _____, who is personally known to me or produced a/n _____ state driver's license as identification.

[NOTARY SEAL]

Notary Public, State of _____

Notary Printed Name: _____

Commission No.: _____

My Commission Expires: _____



Good Faith Effort Compliance Plan Guidelines

for Women/Minority Business Enterprise/Small Local Business Enterprise Participation
City of Tampa - Equal Business Opportunity Program
(MBD Form 50 – detailed instructions on page 2 of 2)

Contract Name _____ Bid Date _____

Bidder/Proposer _____

Signature _____ Date _____

Name _____ Title _____

The Compliance Plan with attachments is a true account of Good Faith Efforts (GFE) made to achieve the participation goals as specified for Women/Minority Business Enterprises/Small Local Business Enterprises (WMBE/SLBE) on the referenced contract:

The WMBE/SLBE participation **Goal is Met or Exceeded**. See DMI Forms 10 and 20 which accurately report all subcontractors solicited and all subcontractors to-be-utilized.

The WMBE/SLBE participation Goal is **Not Achieved**. The following list is an overview of the baseline GFE action steps already performed. Furthermore, it is understood that these GFE requirements are weighted in the compliance evaluation based on the veracity and demonstrable degree of documentation provided with the bid/proposal:

(Check applicable boxes below. Must enclose supporting documents accordingly with remarks)

- (1) Solicited through reasonable and available means the interest of WMBE/SLBEs that have the capability to perform the work of the contract. The Bidder or Proposer must solicit this interest within sufficient time to allow the WMBE/SLBEs to respond. The Bidder or Proposer must take appropriate steps to follow up initial solicitations with interested WMBE/SLBEs. See DMI report forms for subcontractors solicited. See enclosed supplemental data on solicitation efforts. Qualifying Remarks:
- (2) Provided interested WMBE/SLBEs with adequate, specific scope information about the plans, specifications, and requirements of the contract, including addenda, in a timely manner to assist them in responding to the requested-scope identified by bidder/proposer for the solicitation. See enclosed actual solicitations used. Qualifying Remarks:
- (3) Negotiated in good faith with interested WMBE/SLBEs that have submitted bids (e.g. adjusted quantities or scale). Documentation of negotiation must include the names, addresses, and telephone numbers of WMBE/SLBEs that were solicited; the date of each such solicitation; a description of the information provided regarding the plans and specifications for the work selected for subcontracting; and evidence as to why agreements could not be reached with WMBE/SLBEs to perform the work. Additional costs involved in soliciting and using subcontractors is not a sufficient reason for a bidder/proposer's failure to meet goals or achieve participation, as long as such costs are reasonable. Bidders are not required to accept excessive quotes in order to meet the goal. DMI Utilized Forms for sub-(contractor/consultant) reflect genuine negotiations This project is an RFO/RFP in nature and negotiations are limited to clarifications of scope/specifications and qualifications. See enclosed documentation. Qualifying Remarks:
- (4) Not rejecting WMBE/SLBEs as being unqualified without justification based on a thorough investigation of their capabilities. The WMBE/SLBEs standing within its industry, membership in specific groups, organizations / associations and political or social affiliations are not legitimate causes for rejecting or not soliciting bids to meet the goals. Not applicable. See attached justification for rejection of a subcontractor's bid or proposal. Qualifying Remarks:
- (5) Made scope(s) of work available to WMBE/SLBE subcontractors and suppliers; and, segmented portions of the work or material consistent with the available WMBE/SLBE subcontractors and suppliers, so as to facilitate meeting the goal. Sub-Contractors were allowed to bid on their own choice of work or trade without restriction to a pre-determined portion. See enclosed comments. Qualifying Remarks:
- (6) Made good faith efforts, despite the ability or desire of Bidder/Proposer to perform the work of a contract with its own forces/organization. A Bidder/Proposer who desires to self-perform the work of a contract must demonstrate good faith efforts if the goal has not been met. Sub-Contractors were not prohibited from submitting bids/proposals and were solicited on work typically self-performed by the prime. Qualifying Remarks:
- (7) Segmented portions of the work to be performed by WMBE/SLBEs in order to increase the likelihood that the goals will be met. This includes, where appropriate, breaking out contract work items into economically feasible units (quantities/scale) to facilitate WMBE/SLBE participation, even when the Bidder/Proposer might otherwise prefer to perform these work items with its own forces. Sub-Contractors were allowed to bid on their own choice of work or trade without restriction to a pre-determined portion. Sub-Contractors were not prohibited from submitting bids/proposals and were solicited on work typically self-performed by the prime. See enclosed comments. Qualifying Remarks:
- (8) Made efforts to assist interested WMBE/SLBEs in obtaining bonding, lines of credit, or insurance as required by the city or contractor. See enclosed documentation on initiatives undertaken and methods to accomplish. Qualifying Remarks:
- (9) Made efforts to assist interested WMBE/SLBEs in obtaining necessary equipment, supplies, materials, or related assistance or services, including participation in an acceptable mentor-protégé program. See enclosed documentation of initiatives and/or agreements. Qualifying Remarks:
- (10) Effectively used the services of the City and other organizations that provide assistance in the recruitment and placement of WMBE/SLBEs. See enclosed documentation. The following services were used:

Note: Provide any unsolicited information that will support the Bid/RFP Compliance Evaluation. Named Documents Are:



Participation Plan: Guidance for Complying with Good Faith Efforts Outreach
(page 2 of 2)

1. All firms on the WMBE/SLBE Goal Setting List must be solicited and documentation provided for email, fax, letters, phone calls, and other methods of outreach/communication with the listed firms. The DMI Solicited and DMI-Utilized forms must be completed for all firms solicited or utilized. Other opportunities for subcontracting may be explored by consulting the City of Tampa MBD Office and/or researching the on-line Diversity Management Business System Directory for Tampa certified WMBE/SLBE firms.
2. Solicitation of WMBE/SLBEs, via written or electronic notification, should provide specific information on the services needed, where plans can be reviewed and assistance offered in obtaining these, if required. Solicitations should be sent a minimum of a week (i.e. 5 business days or more) before the bid/proposal date. Actual copies of the bidder's solicitation containing their scope specific instructions should be provided.
3. With any quotes received, a follow-up should be made when needed to confirm detail scope of work. For any WMBE/SLBE low quotes rejected, an explanation shall be provided detailing negotiation efforts.
4. If a low bid WMBE/SLBE is rejected or deemed unqualified the contractor must provide an explanation and supporting documentation for this decision.
5. Prime shall break down portions of work into economical feasible opportunities for subcontracting. The WMBE/SLBE directory may be useful in identifying additional subcontracting opportunities and firms not listed in the "WMBE/SLBE Goal Setting Firms List."
6. Contractor shall not preclude WMBE/SLBEs from bidding on any part of work, even if the Contractor may desire to self-perform the work.
7. Contractor shall avoid relying solely on subcontracting out work-scope where WMBE/SLBE availability is not sufficient to attain the pre-determined subcontract goal set for the Bid or when targeted sub-consultant participation is stated within the RFP/RFQ.
8. In its solicitations, the Bidder should offer assistance to WMBE/SLBEs in obtaining bonding, insurance, et cetera, if required of subcontractors by the City or Prime Contractor.
9. In its solicitation, the Bidder should offer assistance in obtaining equipment for a specific job to WMBE/SLBEs, if needed.
10. Contractor should use the services offered by such agencies as the City of Tampa Minority and Small Business Development Office, Hillsborough County Entrepreneur Collaborative Center, Hillsborough County Economic Development Department's MBE/SBE Program and the NAACP Empowerment Center to name a few for the recruitment and placement of WMBEs/SLBEs.



Failure to Complete, Sign and Submit Both Forms 10 & 20 SHALL render the Bid or Proposal Non-Responsive

**Page 1 of 4 – DMI Solicited/Utilized Schedules
City of Tampa – Schedule of **All Solicited** Sub-(Contractors/Consultants/Suppliers)
(FORM MBD-10)**

Contract No.: _____ Contract Name: _____
 Company Name: _____ Address: _____
 Federal ID: _____ Phone: _____ Fax: _____ Email: _____

Check applicable box(es). Detailed Instructions for completing this form are on page 2 of 4.

- No Firms were contacted or solicited for this contract.
- No Firms were contacted because: _____
- See attached list of additional Firms solicited and all supplemental information (List must comply to this form)
Note: Form MBD-10 must list ALL subcontractors solicited including Non-minority/small businesses

NIGP Code Categories: Buildings = 909, General = 912, Heavy = 913, Trades = 914, Architects = 906, Engineers & Surveyors = 925, Supplier = 912-77

S = SLBE W=WMBE O = Neither	Company Name Address Phone, Fax, Email	Type of Ownership (F=Female M=Male) BF BM = African Am. HF HM = Hispanic AF AM = Asian Am. NF NM = Native Am. CF CM = Caucasian	Trade or Services NIGP Code (listed above)	Contact Method L=Letter F=Fax E=Email P=Phone	Quote or Response Received Y/N

Failure to Complete, Sign and Submit
this form with your Bid or Proposal
Shall render the Bid Non-Responsive
(Do Not Modify This Form)

It is hereby certified that the information provided is an accurate and true account of contacts and solicitations for sub-contracting opportunities on this contract.

Signed: _____ Name/Title: _____ Date: _____

**Failure to Complete, Sign and Submit Both Forms 10 & 20 SHALL render the Bid or Proposal Non-Responsive
Forms must be included with Bid / Proposal**



Instructions for completing **The Sub-(Contractors/Consultants/ Suppliers) Solicited Form (Form MBD-10)**

This form must be submitted with all bids or proposals. **All** subcontractors (regardless of ownership or size) solicited and subcontractors from whom unsolicited quotations were received must be included on this form. The instructions that follow correspond to the headings on the form required to be completed. **Note:** Ability or desire to self-perform all work shall not exempt the prime from Good Faith Efforts to achieve participation.

- **Contract No.** This is the number assigned by the City of Tampa for the bid or proposal.
- **Contract Name.** This is the name of the contract assigned by the City of Tampa for the bid or proposal.
- **Contractor Name.** The name of your business and/or doing business as (dba) if applicable.
- **Address.** The physical address of your business.
- **Federal ID.** FIN. A number assigned to your business for tax reporting purposes.
- **Phone.** Telephone number to contact business.
- **Fax.** Fax number for business.
- **Email.** Provide email address for electronic correspondence.
- **No Firms were contacted or solicited for this contract.** Checking the box indicates that a pre-determined Subcontract Goal or Participation Plan Requirement was not set by the City resulting in your business not using subcontractors and will self-perform all work. If during the performance of the contract you employ subcontractors, the City must pre-approve subcontractors. Use of the “Sub-(Contractors/Consultants/Suppliers) Payments” form (MBD Form-30) must be submitted with every pay application and invoice. **Note:** Certified **SLBE or WMBE firms** bidding as Primes **are not exempt** from outreach and solicitation of subcontractors.
- **No Firms were contacted because.** Provide brief explanation why no firms were contacted or solicited.
- **See attached documents.** Check box, if after you have completed the DMI Form in its entirety, you need more space to list additional firms and/or if you have supplemental information/documentation relating to the form. All DMI data not submitted on the MBD Form-10 must be in the same format and have all requested data from MBD Form-10 included.

The following instructions are for information of any and all subcontractors solicited.

- **“S” = SLBE, “W” = WMBE.** Enter “S” for firms Certified by the City as Small Local Business Enterprises and/or “W” for firms Certified by the City as either Women/Minority Business Enterprise; **“O” = Non-certified others.**
- **Federal ID.** FIN. A number assigned to a business for tax reporting purposes. This information is critical in proper identification and payment of the contractor/subcontractor.
- **Company Name, Address, Phone & Fax.** Provide company information for verification of payments.
- **Type of Ownership.** Indicate the Ethnicity and Gender of the owner of the subcontracting business.
- **Trade, Services, or Materials** indicate the trade, service, or materials provided by the subcontractor. NIGP codes aka “National Institute of Governmental Purchasing” are listed at top section of document.
- **Contact Method L=letter, F=fax, E=Email, P=Phone.** Indicate with letter the method(s) of soliciting for bid.
- **Quote or Resp. (response) Rec’d (received) Y/N.** Indicate “Y” Yes if you received a quotation or if you received a response to your solicitation. Indicate “N” No if you received no response to your solicitation from the subcontractor. Must keep records: log, ledger, documentation, etc. that can validate/verify.

If additional information is required or you have questions, please contact the Equal Business Opportunity Program - Minority and Small Business Development Office at (813) 274-5522.



Failure to Complete, Sign and Submit Both Forms 10 & 20 SHALL render the Bid or Proposal Non-Responsive

Page 3 of 4 – DMI Solicited/Utilized Schedules
City of Tampa – Schedule of All To-Be-Utilized Sub-(Contractors/Consultants/Suppliers)
(FORM MBD-20)

Contract No.: _____ Contract Name: _____
Company Name: _____ Address: _____
Federal ID: _____ Phone: _____ Fax: _____ Email: _____

Check applicable box(es). Detailed Instructions for completing this form are on page 4 of 4.

See attached list of additional Firms Utilized and all supplemental information (List must comply to this form)

Note: Form MBD-20 must list ALL subcontractors To-Be-Utilized including Non-minority/small businesses

No Subcontracting/consulting (of any kind) will be performed on this contract.

No Firms are listed to be utilized because: _____

NIGP Code General Categories: Buildings = 909, General = 912, Heavy = 913, Trades = 914, Architects = 906, Engineers & Surveyors = 925, Supplier = 912-77

Enter "S" for firms Certified as Small Local Business Enterprises, "W" for firms Certified as Women/Minority Business Enterprise, "O" for Other Non-Certified

S = SLBE W=WMBE O =Neither	Company Name Address Phone, Fax, Email	Type of Ownership (F=Female M=Male) BF BM = African Am. HF HM = Hispanic Am. AF AM = Asian Am. NF NM = Native Am. CF CM = Caucasian	Trade, Services, or Materials NIGP Code Listed above	\$ Amount of Quote. Letter of Intent (LOI) if available	Percent of Scope or Contract %

Failure to Complete, Sign and Submit
this form with your Bid or Proposal
Shall render the Bid Non-Responsive.
(Do Not Modify This Form)

Total ALL Subcontract / Supplier Utilization \$ _____
Total SLBE Utilization \$ _____
Total WMBE Utilization \$ _____
Percent SLBE Utilization of Total Bid/Proposal Amt. _____% Percent WMBE Utilization of Total Bid/Proposal Amt. _____%

It is hereby certified that the following information is a true and accurate account of utilization for sub-contracting opportunities on this Contract.

Signed: _____ Name/Title: _____ Date: _____

Failure to Complete, Sign and Submit Both Forms 10 & 20 SHALL render the Bid or Proposal Non-Responsive
Forms must be included with Bid / Proposal



Page 4 of 4 DMI – Solicited/**Utilized**

Instructions for completing **The Sub-(Contractors/Consultants/ Suppliers) to be Utilized Form (Form MBD-20)**

This form must be submitted with all bids or proposals. All subcontractors (regardless of ownership or size) projected to be utilized must be included on this form. Note: Ability or desire to self-perform all work shall not exempt the prime from Good Faith Efforts to achieve participation.

Contract No. This is the number assigned by the City of Tampa for the bid or proposal.

- **Contract Name.** This is the name of the contract assigned by the City of Tampa for the bid or proposal.
- **Contractor Name.** The name of your business and/or doing business as (dba) if applicable.
- **Address.** The physical address of your business.
- **Federal ID. FIN.** A number assigned to your business for tax reporting purposes.
- **Phone.** Telephone number to contact business.
- **Fax.** Fax number for business.
- **Email.** Provide email address for electronic correspondence.
- **No Subcontracting/consulting (of any kind) will be performed on this contract.** Checking box indicates your business will not use subcontractors when no Subcontract Goal or Participation Plan Requirement was set by the City, but will self-perform all work. When subcontractors are utilized during the performance of the contract, the “Sub-(Contractors/Consultants/Suppliers) Payments” form (MBD Form-30) must be submitted with every pay application and invoice. Note: certified **SLBE or WMBE firms** bidding as Primes **are not exempt** from outreach and solicitation of subcontractors, including completion and submitting Form-10 and Form-20.
- **No Firms listed To-Be-Utilized.** Check box; provide brief explanation why no firms were retained when a goal or participation plan requirement was set on the contract. Note: mandatory compliance with Good Faith Effort outreach (GFECF) requirements applies (MBD Form-50) and supporting documentation must accompany the bid.
- **See attached documents.** Check box, if after completing the DMI Form in its entirety, you need more space to list additional firms and/or if you have supplemental information/documentation relating to the scope/value/percent utilization of subcontractors. Reproduce copies of MBD-20 and attach. All data not submitted on duplicate forms must be in the same format and content as specified in these instructions.

The following instructions are for information of Any and All subcontractors To Be Utilized.

- **Federal ID. FIN.** A number assigned to a business for tax reporting purposes. This information is critical in proper identification of the subcontractor.
- **“S” = SLBE, “W” = WMBE.** Enter “S” for firms Certified by the City as Small Local Business Enterprises and/or “W” for firms Certified by the City as Women/Minority Business Enterprise; **“O” = Non-certified others.**
- **Company Name, Address, Phone & Fax.** Provide company information for verification of payments.
- **Type of Ownership.** Indicate the Ethnicity and Gender of the owner of the subcontracting business.
- **Trade, Services, or Materials (NIGP code if Known)** Indicate the trade, service, or material provided by the subcontractor. Abbreviated list of NIGP is available at <http://www.tampagov.net/mbd> “Information Resources”.
- **Amount of Quote, Letters of Intent** (required for both SLBEs and WMBEs).
- **Percent of Work/Contract.** Indicate the percent of the total contract price the subcontract(s) represent. For CCNA only (i.e. Consultant A/E Services) you must indicate subcontracts as percent of total scope/contract.
- **Total Subcontract/Supplier Utilization.** – Provide total dollar amount of all subcontractors/suppliers projected to be used for the contract. (Dollar amounts may be optional in CCNA depending on solicitation format).
- **Total SLBE Utilization.** Provide total dollar amount for all projected SLBE subcontractors/Suppliers used for this contract. (Dollar amounts may be optional in CCNA proposals depending on the solicitation format).
- **Total WMBE Utilization.** Provide total dollar amount for all projected WMBE subcontractors/Suppliers used for this contract. (Dollar amounts may be optional in CCNA proposals depending on the solicitation format).
- **Percent SLBE Utilization.** Total amount allocated to SLBEs divided by the total bid/proposal amount.
- **Percent WMBE Utilization.** Total amount allocated to WMBEs divided by the total bid/proposal amount.

If additional information is required or you have questions, please contact the Equal Business Opportunity Program - Minority and Small Business Development Office at (813) 274-5522.

TAMPA BID BOND
Contract 18-C-00030; City-wide Meter, Hydrant, Valve Installation and Replacement

KNOW ALL MEN BY THESE PRESENTS, that we, _____

_____ (hereinafter called the Principal) and _____

(hereinafter called the Surety) a Corporation chartered and existing under the laws of the State of _____, with its principal offices in the City of _____, and authorized to do business in the State of Florida, are held and firmly bound unto the City of Tampa, a Municipal Corporation of Hillsborough County, Florida, in the full and just sum of 5% of the amount of the (Bid) (Proposal) good and lawful money of the United States of America, to be paid upon demand of the City of Tampa, Florida, to which payment will and truly to be made we bind ourselves, our heirs, executors, administrators, successors, and assigns, jointly and severally and firmly these presents.

WHEREAS, the Principal is about to submit, or has submitted to the City of Tampa, Florida, a Proposal for the construction of certain facilities for the City designated Contract 18-C-00030, City-wide Meter, Hydrant, Valve Installation and Replacement.

WHEREAS, the Principal desires to file this Bond in accordance with law, in lieu of a certified Bidder's check otherwise required to accompany this Proposal.

NOW, THEREFORE: The conditions of this obligation are such that if the Proposal be accepted, the Principal shall, within twenty (20) days after the date of receipt of written Notice of Award, execute a contract in accordance with the Proposal and upon the terms, conditions and price set forth therein, in the form and manner required by the City of Tampa, Florida and execute a sufficient and satisfactory Public Construction Bond payable to the City of Tampa, Florida in an amount of one hundred percent (100%) of the total contract price, in form and with security satisfactory to said City, then this Bid Bond obligation is to be void; otherwise to be and remain in full force and virtue in law, and the Surety shall, upon failure of the Principal to comply with any or all of the foregoing requirements within the time specified above, immediately pay to the aforesaid City, upon demand, the amount thereof, in good and lawful money of the United States of America, not as a penalty, but as liquidated damages.

IN TESTIMONY THEREOF, the Principal and Surety have caused these presents to be duly signed and sealed this _____ day of _____, 20____.

Principal

BY _____

TITLE _____

BY _____

TITLE _____

(SEAL)

Producing Agent

Producing Agent's Address

Name of Agency

The addition of such phrases as "not to exceed" or like import shall render the (Bid) (Proposal) non-responsive.

AGREEMENT

For furnishing all labor, materials and equipment, together with all work incidental thereto, necessary and required for the performance of the work for the construction of Contract 18-C-00030 in accordance with your Proposal dated _____, amounting to a total of \$_____ as completed in accordance with subsections I-2.09 and I-2.10 of the Instruction to Bidders.

This AGREEMENT, made and entered into in triplicate, between the City of Tampa, Florida, hereinafter called the City, and _____ hereinafter called the Contractor, as of the _____ day of _____, 20__ when the City Council of the City of Tampa, Florida adopted a Resolution authorizing, among other things, the Mayor's execution of this Agreement.

WITNESSETH that, in consideration of the mutual stipulations, agreements, and covenants herein contained, the parties hereto have agreed and hereby agree with each other, the Party of the First Part for itself, its successors and assigns, and the Party of the Second Part for itself, or himself, or themselves, and its successors and assigns, or his or their executors, administrators and assigns, as follows:

Contract 18-C-00030; City-wide Meter, Hydrant, Valve Installation and Replacement, shall include, but not be limited to, furnishing and installing water mains and appurtenances ranging in size from 2-inch to 16-inch diameter including concrete masonry, curbs and sidewalks; paving, landscaping, grouting, brick street construction with all associated work required for a complete project in accordance with the Contract Documents.

Contract Documents referred to in Article 1.01 of this Agreement also includes this volume, applicable standard drawings, the plans and any provisions referred to whether actually attached or not.

TAMPA AGREEMENT

SECTION 1 GENERAL

ARTICLE 1.01 THE CONTRACT

Except for titles, subtitles, headings, running headlines, and tables of contents (all of which are printed herein merely for convenience), the following, except for such portions thereof as may be specifically excluded, constitute the Contract:

The Notice to Bidders;
The Instructions to Bidders, including Special Instructions and General Instructions;
The Proposal;
The Bid Bond;
The Certification of Nonsegregated Facilities;
The Notice of Award;
The Agreement;
The Performance Bond;
The Notice To Proceed;
The Specifications, including the General Provisions, the Workmanship and Materials, the Specific Provisions or the Contract Items
The Plans;
All Supplementary Drawings Issued after award of the Contract;
All Addenda issued by the City prior to the receipt of proposals;
All provisions required by law to be inserted in this Contract, whether actually inserted or not.

ARTICLE 1.02 DEFINITIONS

The following words and terms, or pronouns used in their stead, shall, wherever they appear in this Contract, be construed as follows, unless different meaning is clear from the context:

(a)"City" shall mean the City of Tampa, Florida, represented by its Mayor and City Council, Party of the First Part, or such other City official as shall be duly empowered to act for the City on matters relating to this Contract.

(b)"Contractor" shall mean the Party of the Second Part hereto, whether corporation, firm or individual, or any combination thereof, and its, their, or his successors, personal representatives, executors, administrators, and assigns, and any person, firm or corporation who or which shall at any time be substituted in the place of the Party of the Second Part under this Contract.

(c)"Engineer" shall mean the Director of the Department or his duly authorized representative.

(d)"Consultant" shall mean the engineering or architectural firm or individual employed by the City to consult with and advise the City in the construction of the project.

(e)"Surety" shall mean any person, firm or corporation that has executed as Surety the Contractor's Performance Bond securing the performance of this Contract.

(f)"The Work" shall mean everything expressly or implied required to be furnished and done by the Contractor under the Contract, and shall include both Contract Work

and Extra Work.

(g)"Contract Work" shall mean everything expressly or implied required to be furnished and done by the Contractor by any one or more of the Contract parts referred to in Article 1.01 hereof, except Extra Work, as hereinafter defined; it being understood that, in case of any inconsistency in or between any part or parts of this Contract, the Engineer shall determine which shall prevail.

(h)"Contract" or "Contract Documents" shall mean each of the various part of the Contract referred to in Article 1.01 hereof, both as a whole and severally.

(i)"Extra Work" shall mean work other than that required either expressly or implied by the contract in its present form.

(j)"Plans" shall mean only those drawings specifically referred to as such in these documents, or in any Addendum. Drawings issued after the execution of the Contract to explain further, or to illustrate, or to show changes in the work, will be known as "Supplementary Drawings" and shall be binding upon the Contractor with the same force as the Plans.

(k)"Specifications" shall mean all of the directions, requirements, and standards of performance applying to the work, as hereinafter detailed and designated as such, or which may be issued in an addendum.

(l)"Addendum or Addenda" shall mean the additional contract provisions issued in writing prior to the receipt of bids.

(m)"Notice" shall mean written notice. Notice shall be served upon the Contractor, either personally or by leaving the said notice at his residence or with any employee found on the work, or addressed to the Contractor at the residence or place of business given in his proposal and deposited in a postpaid wrapper in any post office box regularly maintained by the United States Post Office.

(n)"Project" shall mean the entire improvement package or related work. The "project" may consist of several different, but related, contracts.

(o)"Site" shall mean, and be limited to, the area upon or in which the Contractor's operations are carried on and such other appropriate areas as may be designed as such by the Engineer.

(p)"Subcontractor" shall mean any person, firm, or corporation, other than employees of the Contractor, who or which contracts with the Contractor to furnish, or actually furnishes labor, or labor and materials, or labor and equipment or labor, materials, and equipment at the site.

(q)Whenever in the Contract the words "directed", "required", "permitted", "ordered", "designated", "prescribed", and words of like import are used, they shall imply the direction, requirement, permission, order, designation, or prescription of the Engineer; and "approved", "acceptable", "satisfactory", "in the judgement of", and words of like import shall mean approved by, or acceptable to, or satisfactory to, or in the judgment of the Engineer.

(r)Whenever in the Contract the word "day" is used, it shall mean calendar day.

(s)"Final Acceptance" shall mean acceptance of the

work as evidenced by an official resolution of the City. Such acceptance shall be deemed to have taken place only if and when an approving resolution has been adopted by the City Council. The final acceptance shall be signed only after the City has assured itself by tests, inspection, or otherwise, that all of the provisions of the Contract have been carried out to its satisfaction.

(t)"Eastern Standard Time" shall be construed as the time being observed in the City on the day proposals are received or other documents issued or signed.

SECTION 2 POWERS OF THE CITY'S REPRESENTATIVES

ARTICLE 2.01 THE ENGINEER

It is covenanted and agreed that the Engineer, in addition to those matters elsewhere herein expressly made subject to his determination, direction, or approval, shall have the power, subject to such express provisions and limitations herein contained as are not in conflict herewith, and subject to review by the Mayor and City Council:

(a)To monitor the performance of the work.

(b)To determine the amount, kind, quality, sequence, and location of the work to be paid for hereunder and, when completed, to measure such work for payment.

(c)To determine all questions of an engineering character in relation to the work, to interpret the Plans, Specifications and Addenda.

(d)To determine how the work of this Contract shall be coordinated with the work of other contractors engaged simultaneously on this project.

(e)To make minor changes in the work as he deems necessary, provided such changes do not result in a net increase in the cost to the City or to the Contractor of the work to be done under the Contract.

(f)To amplify the Plans, add explanatory information and furnish additional Specifications and Drawings consistent with the intent of the Contract Documents.

The power of the Engineer shall not be limited to the foregoing enumeration, for it is the intent of this Contract that all of the work shall be subject to his determinations and approval, except where the determination or approval of someone other than the Engineer is expressly called for herein and except as subject to review by the Mayor and City Council. All orders of the Engineer requiring the Contractor to perform work as Contract work shall be promptly obeyed by the Contractor.

The Engineer shall not, however, have the power to issue an extra work order, and the performance of such work on the order of the Engineer without previously obtaining written confirmation thereof from the Mayor in accordance with Article 7.02 hereof may constitute a waiver of any right to extra compensation therefor. The Contractor is warned that the Engineer has no power to change the terms and provisions of this Contract, except minor changes where such change results in no net increase in the Contract Price.

ARTICLE 2.02 DIRECTOR

The Director of the Department in addition to those matters

expressly made subject to his determination, direction or approval in his capacity as "Engineer", shall also have the power:

(a)To review any and all questions in relation to this Contract and its performance, except as herein otherwise specifically provided, and his determination upon such review shall be final and conclusive upon the Contractor.

(b)With the approval of the Mayor and City Council to authorize modifications or changes in the Contract so as to require: (1) the performance of extra work, or (2) the omission of Contract work whenever he deems it in the interest of the City to do so, or both.

(c)To suspend the whole or any part of the work whenever, in his judgment, such suspension is required: (1) in the interest of the City generally, or (2) to coordinate the work of the various Contractors engaged on this project, or (3) to expedite the completion of the entire project, even though the completion of this particular Contract may be thereby delayed, without compensation to the Contractor for such suspension other than extending the time for the completion of the work, as much as it may have been, in the opinion of the City, delayed by such a suspension.

(d)If, before the final acceptance of all the work contemplated herein, it shall be deemed necessary to take over, use, occupy, or operate any part of the completed or partly completed work, the Engineer shall have the right to do so and the Contractor will not, in any way, interfere with or object to the use, occupation, or operation of such work by the City after receipt of notice in writing from the Engineer that such work or part thereof will be used by the City on and after the date specified in such notice. Such taking over, use, occupancy or operation of any part of the completed or partially completed work shall not constitute final acceptance or approval of any such part of the work.

ARTICLE 2.03 NO ESTOPPEL

The City shall not, nor shall any department, officer, agent, or employee thereof, be bound, precluded, or estopped by any determination, decision, acceptance, return, certificate, or payment made or given under or in connection with this Contract by any officer, agent or employee of the City at any time either before or after final completion and acceptance of the work and payment therefor: (a) from showing the true and correct classification, amount, quality, or character of the work done, or that any determination, decision, acceptance, return certificate or payment is untrue, incorrect or improperly made in any particular, or that the work or any part thereof does not in fact conform to the requirements of the Contract Documents, and (b) from demanding and recovering from the Contractor any overpayments made to him or such damages as it may sustain by reason his failure to comply with the requirements of the Contract of Documents, or both.

ARTICLE 2.04 NO WAIVER OF RIGHTS

Neither the inspection, nor any order, measurements or certificate of the City or its employees, officers, or agents, nor by any order of the City for payment of money, nor any money, nor payments for or acceptance of the whole or any part of the work by the City, nor any extension of time, nor any changes in the Contract, Specifications or Plans, nor any possession by the City or its employees shall operate as a

waiver of any provisions of this Contract, nor any power herein provided nor shall any waiver of any breach of this Contract be held as a waiver of any other subsequent breach.

Any remedy provided in this Contract shall be taken and construed as cumulative, namely, in addition to each and every other suit, action, or legal proceeding. The City shall be entitled as of right to an injunction against any breach of the provisions of this Contract.

SECTION 3 PERFORMANCE OF WORK

ARTICLE 3.01 CONTRACTOR'S RESPONSIBILITY

The Contractor shall do all the work and furnish, at his own cost and expense, all labor, materials, equipment, and other facilities, except as herein otherwise provided, as may be necessary and proper for performing and completing the work under this Contract. The Contractor shall be responsible for the entire work until completed and finally accepted by the City.

The work shall be performed in accordance with the true intent and meaning of the Contract Documents. Unless otherwise expressly provided, the work must be performed in accordance with the best modern practice, with materials as specified and workmanship of the highest quality, all as determined by and entirely to the satisfaction of the Engineer.

Unless otherwise expressly provided, the means and methods of construction shall be such as the Contractor may choose, subject, however, to the approval of the Engineer. Only adequate and safe procedure, methods, structures and equipment shall be used. The Engineer's approval or the Engineer's failure to exercise his right thereon shall not relieve the Contractor of obligations to accomplish the result intended by the Contract, nor shall such create a cause of action for damages.

ARTICLE 3.02 COMPLIANCE WITH LAWS

The Contractor must comply with all local, State and Federal laws, rules, ordinances and regulations applicable to this Contract and to the work done hereunder, and must obtain, at his own expense, all permits, licenses or other authorization necessary for the prosecution of the work.

No work shall be performed under this Contract on Sundays, legal holidays or after regular working hours without the express permission of the Engineer. Where such permission is granted, the Engineer may require that such work be performed without additional expense to the City.

ARTICLE 3.03 INSPECTION

During the progress of the work and up to the date of final acceptance, the Contractor shall, at all times, afford the representatives of the City, the Florida Department of Environmental Regulation, and if applicable, the Federal Environmental Protection Agency and the Federal Department of Labor every reasonable, safe and proper facility for inspecting the work done or being done at the

site. The inspection of any work shall not relieve the Contractor of any of his obligations to perform proper and satisfactory work as herein specified. Finished or unfinished work found not to be in strict accordance with the Contract shall be replaced as directed by the Engineer, even though such work may have been previously approved and payment made therefor.

The City shall have the right to reject materials and workmanship which are defective or require their correction. Rejected work and materials must be promptly removed from the site, which must at all times be kept in a reasonably clean and neat condition.

Failure or neglect on the part of the City to condemn or reject bad or inferior work or materials shall not be construed to imply an acceptance of such work or materials, if it becomes evident at any time prior to the final acceptance of the work by the City. Neither shall it be construed as barring the City at any subsequent time from the recovery of damages of such a sum of money as may be needed to build anew all portions of the work in which inferior work or improper materials were used, wherever found.

Should it be considered necessary or advisable by the City at any time before final acceptance of the entire work to make examinations of work already completed, by removing or tearing out all or portions of such work, the Contractor shall, on request, promptly furnish all necessary facilities, labor, and material for that purpose. If such work is found to be defective in any material respect, due to the fault of the Contractor or his subcontractors, he shall defray all expenses of such examination and of satisfactory reconstruction. If, however, such work is found to meet the requirements of the Contract, the cost of examination and restoration of the work shall be considered an item of extra work to be paid for in accordance with the provisions of Article 7.02 hereof.

ARTICLE 3.04 PROTECTION

During performance and until final acceptance, the Contractor shall be under an absolute obligation to protect the finished and unfinished work against any damage, loss, or injury. The Contractor shall take proper precaution to protect the finished work from loss or damage, pending completion and the final acceptance of all the work included in the entire Contract, provided that such precaution shall not relieve the Contractor from any and all liability and responsibility for loss or damage to the work occurring before final acceptance by the City. Such loss or damage shall be at the risk of and borne by the Contractor, whether arising from acts or omissions of the Contractor or others. In the event of any such loss or damage, the Contractor shall forthwith repair, replace, and make good the work without extension of time therefor, except as may be otherwise provided herein.

The provisions of this Article shall not be deemed to create any new right of action in favor of third parties against the Contractor or the City.

ARTICLE 3.05 PRESERVATION OF PROPERTY

The Contractor shall preserve from damage all property along the line of the work, or which is in the vicinity of or is in anywise affected by the work, the removal or destruction of which is not called for by the Plans. This applies, but is not limited, to the public utilities, trees, lawn areas, building monuments, fences, pipe and underground structures, public streets (except natural wear and tear of streets resulting from legitimate use thereof by the Contractor), and wherever such property is damaged due to the activities of the Contractor, it shall be immediately restored to its original condition by the Contractor and at his own expense.

In case of failure on the part of the Contractor to restore such property, or make good such damage or injury, the City may, upon forty-eight (48) hour written notice, proceed to repair, rebuild, or otherwise restore such property as may be deemed necessary, and the cost thereof will be deducted from any monies due or which may become due the Contractor under this Contract. Nothing in this clause shall prevent the Contractor from receiving proper compensation for the removal, damage, or replacement of any public or private property not shown on the Plans, when this is made necessary by alteration of grade or alignment authorized by the Engineer, provided that such property has not been damaged through fault of the Contractor, his employees or agents.

ARTICLE 3.06 BOUNDARIES

The Contractor shall confine his equipment, apparatus, the storage of materials, supplies and apparatus of his workmen to the limits indicated on the plans, by law, ordinances, permits or direction of the Engineer.

ARTICLE 3.07 SAFETY AND HEALTH REGULATIONS

The Contractor shall comply with the Department of Labor Safety and Health Regulations for construction promulgated under the Occupational Safety and Health Act of 1970 (PL 91- 596) and under Section 107 of the Contract Work Hours and Safety Standards Act (PL91-54).

ARTICLE 3.08 TAXES

All taxes of any kind and character payable on account of the work done and materials furnished under this Contract shall be paid by the Contractor and shall be deemed to have been included in his bid. The laws of the State of Florida provide that sales and use taxes are payable by the Contractor upon the tangible personal property incorporated in the work and such taxes shall be paid by the Contractor and shall be deemed to have been included in his bid.

ARTICLE 3.09 ENVIRONMENTAL CONSIDERATIONS

The Contractor, in the performance of the work under this Contract, shall comply with all Local, State and Federal laws, statutes, ordinances, rules and regulations applicable to protection of the environment; and, in the event he violates any of the provisions of same, he shall be answerable to the Local, State and Federal agencies designated by law to protect the environment. In the event the City receives, from any of the environmental agencies, a citation which is occasioned by an act or omission of the Contractor or his

subcontractor or any officers, employees or agents of either, it is understood and agreed that the Contractor shall automatically become a party-respondent under said citation; and the City immediately shall notify the Contractor and provide him with a copy of said citation.

The Contractor shall comply with the requirements of the citation and correct the offending condition(s) within the time stated in said citation and further shall be held fully responsible for all fines and/or penalties.

**SECTION 4
TIME PROVISIONS**

ARTICLE 4.01 TIME OF START AND COMPLETION

The Contractor must commence work within thirty (30) days subsequent to the date of the receipt of the "Notice to Proceed" by the City unless otherwise provided in the Specific Provisions and Special Instructions. Time being of the essence of this Contract, the Contractor shall thereafter prosecute the work diligently, using such means and methods of construction as well as secure its full completion in accordance with the requirements of the Contract Documents no later than the date specified therefor, or on the date to which the time for completion may be extended.

The Contractor must complete the work covered by this Contract in the number of consecutive calendar days set forth in the Instructions to Bidders, unless the date of completion is extended pursuant to the provisions of Article 4.05 hereof.

The period for performance shall start from the date of signing of this Agreement by the City.

The actual date of completion will be established after a final inspection as provided in Article 4.07 hereof.

ARTICLE 4.02 PROGRESS SCHEDULE

To enable the work to be laid out and prosecuted in an orderly and expeditious manner, the Contractor shall submit to the Engineer a proposed progress schedule within fifteen (15) days after the award of this Contract.

The schedule shall state the Contract starting date, time for completion and date of completion and shall show the anticipated time of starting and completion of each of the various operations to be performed under this Contract, together with all necessary and appropriate information regarding sequence and correlation of work and an estimated time required for the delivery of all materials and equipment required for the work. The proposed schedule shall be revised as directed by the Engineer until finally approved by him, and, after such approval, shall be strictly adhered to by the Contractor. The approved progress schedule may be changed only with the written permission of the Engineer.

If the Contractor shall fail to adhere to the approved progress schedule or the schedule as revised, he shall promptly adopt such other or additional means and methods of construction as will make up for the time lost, and will assure completion in accordance with the contract time.

ARTICLE 4.03 APPROVAL REQUESTS

From time to time, as the work progresses and in the sequence indicated by the approved schedule, the Contractor must submit to the Engineer a specific request, in writing, for each item of information or approval required of him by the Contract. These requests must be submitted sufficiently in advance of the date upon which the information or approval is actually required by the Contractor to allow for the time the Engineer may take to act upon such submissions or resubmissions. The Contractor shall not have any right to an extension of time on account of delays due to his failure to submit his requests for the required information or the required approval in accordance with these requirements.

ARTICLE 4.04 COORDINATION WITH OTHER CONTRACTORS

During progress of the work, other Contractors may be engaged in performing other work on this project or on other projects on the site. In that event, the Contractor shall coordinate the work to be done hereunder with the work of such other Contractors in such manner as the Engineer may direct.

ARTICLE 4.05 EXTENSION OF TIME

If such an application is made, the Contractor shall be entitled to an extension of time for delay in completion of the work should the Contractor be obstructed or delayed in the commencement, prosecution or completion of any part of said work by any act or delay of the City, or by acts or omissions of other Contractors on this project, or by a riot, insurrection, war, pestilence, acts of public authorities, fire, lightning, hurricanes, earthquakes, tornadoes, floods, extremely abnormal and excessive inclement weather as indicated by the records of the local weather bureau for a five-year period preceding the date of the Contract, or by strikes, or other causes, which causes of delay mentioned in this Article, in the opinion of the City, are entirely beyond the expectation and control of the Contractor.

The Contractor shall, however, be entitled to an extension of time for such causes only for the number of days of delay which the City may determine to be due solely to such causes and only to the extent that such occurrences actually delay the completion of the project and then only if the Contractor shall have strictly complied with all of the requirements of Articles 4.01, 4.02, 4.03 and 4.04 hereof. It is hereby understood that the determination by the Engineer as to the order and sequence of the work shall not in itself constitute a basis for extension of time.

The determination made by the City on an application for an extension of time shall be binding and conclusive on the Contractor.

Delays caused by failure of the Contractor's materialmen, manufacturers, and dealers to furnish approved working drawings, materials, fixtures, equipment, appliances, or other fittings on time or failure of subcontractors to perform their work shall not constitute a basis of extension of time.

The Contractor agrees to make no claim for damages for delay in the performance of this Contract occasioned by any

act or omission to act of the City or any of its representatives or because of any injunction which may be brought against the City or its representatives and agrees that any such claim shall be fully compensated for by an extension of time to complete performance of the work as provided herein.

ARTICLE 4.06 LIQUIDATED DAMAGES

It is mutually agreed between the parties that time is the essence of this Contract and that there will be on the part of the City considerable monetary damage in the event the Contractor should fail to complete the work within the time fixed for completion in the Contract or within the time to which such completion may have been extended.

The amount per day set forth in the Instructions to Bidders is hereby agreed upon as the liquidated damages for each and every calendar day that the time consumed in completing the work under this Contract exceeds the time allowed.

This amount shall, in no event, be considered as a penalty or otherwise than as the liquidated and adjusted damages to the City because of the delay and the Contractor and his Surety agree that the stated sum per day for each such day of delay shall be deducted and retained out of the monies which may become due hereunder and if not so deductible, the Contractor and his Surety shall be liable therefor.

ARTICLE 4.07 FINAL INSPECTION

When the work has been completed in accordance with the requirements of the Contract and final cleaning up performed, a date for final inspection of the work by the Engineer shall be set by the Contractor in a written request therefor, which date shall be not less than ten (10) days after the date of such request. The work will be deemed complete as of the date so set by the Contractor if, upon such inspection, the Engineer determines that no further work remains to be done at the site.

If such inspection reveals interms of work still to be performed, however, the Contractor shall promptly perform them and then request a reinspection. If, upon such inspection, the Engineer determines that the work is complete, the date of final completion shall be deemed to be the last day of such reinspection.

**SECTION 5
SUBCONTRACTS AND ASSIGNMENTS**

ARTICLE 5.01 LIMITATIONS AND CONSENT

The Contractor shall not assign, transfer, convey, sublet or otherwise dispose of this Contract or of his right, title, or interest therein, or his power to execute such Contract, or to assign any monies due or to become due thereunder to any other person, firm or corporation unless the previous written consent of the City shall first be obtained thereto and the giving of any such consent to a particular subcontract or assignment shall not dispense with the necessity of such consent to any further or other assignment.

Before making any subcontract, the Contractor must submit a

written statement to the Engineer, giving the name and address of the proposed contractor, the portion of the work and materials which he is to perform and furnish and any other information tending to prove that the proposed subcontractor has the necessary facilities, skill, integrity, past experience and financial resources to perform the work in accordance with the terms and conditions of this Contract.

If the City finds that the proposed subcontractor is qualified, the Contractor will be notified in writing. The City may revoke approval of any subcontractor when such subcontractor evidences an unwillingness or inability to perform his work in strict accordance with these Contract Documents. Notice of such revocation of approval will be given in writing to the Contractor.

The Contractor will promptly, upon request, file with the City a conformed copy of the subcontract. The Contractor shall cause appropriate provisions to be inserted in all subcontracts relative to the work to bind subcontractors to the Contractor by the terms of these Contract Documents, insofar as applicable to the work of subcontractors, and to give the Contractor the same power as regards terminating any subcontracts that the City may exercise over the Contractor under provisions of these Contract Documents.

The Contractor shall be required to perform with his own forces at least twenty-five (25) percent of the work, unless written consent to subcontract a greater percentage of the work is first obtained from the City.

ARTICLE 5.02 RESPONSIBILITY

The approval by the City of a subcontractor shall not relieve the Contractor of any of his responsibilities, duties, and liabilities hereunder. The Contractor shall be solely responsible to the City for the acts or defaults or omissions of his subcontractor and of such subcontractor's officers, agents, and employees, each of whom shall for all purposes be deemed to be the agent or employee of the Contractor. Nothing contained in the Contract Documents shall create any contractual relationship between any subcontractor and the City.

SECTION 6 SECURITY AND GUARANTY

ARTICLE 6.01 CONTRACT SECURITY

The Contractor shall execute and deliver to the City a Performance Bond on the form as provided herein, in an amount at least equal to one hundred (100) percent of the full Contract price, such Bond to be executed by a surety company acceptable to the City. The surety on such Performance Bond shall be a surety company duly authorized to do business in the State of Florida, and the Bond shall be issued or countersigned by a local resident producing agent of such surety company who is a resident of the State of Florida, regularly commissioned and licensed in said State, and satisfactory evidence of the authority of the person or persons executing such Bond shall be submitted with the Bond. The Performance Bond shall serve as security for the faithful performance of this Contract, including

maintenance and guaranty provisions, and for the payment of all persons performing labor and furnishing materials in connection with the Contract. The premiums on the Performance Bond shall be paid by the Contractor.

If, at any time, the City shall become dissatisfied with any surety or sureties then upon the Performance Bond, or if for any other reason such bond shall cease to be adequate security for the City, the Contractor shall, within five days after notice so to do, substitute an acceptable Bond in such form and sum and signed by such other sureties as may be satisfactory to the City. The premiums on such Bond shall be paid by the Contractor. No further partial payments shall be deemed due or shall be made until the new sureties have qualified.

ARTICLE 6.02 CONTRACTORS INSURANCE

Insurance required shall be as indicated on Special Instructions pages beginning with "INS-1"

ARTICLE 6.03 AGAINST CLAIMS AND LIENS

The City may withhold from the Contractor as much as any approved payments to him as may, in the opinion of the City, be necessary to secure (a) just claims of any persons supplying labor or materials to the Contractor or any of his subcontractors for the work then due and unpaid; (b) loss due to defective work not remedied, or (c) liability, damage, or loss due to injury to persons or damages to the work or property of other contractors, subcontractors, or others, caused by the act or neglect of the Contractor or of any of his subcontractors. The City shall have the right, as agent for the Contractor, to apply any such amounts so withheld in such manner as the City may deem proper to satisfy such claims or to secure such protection. Such application of such money shall be deemed payments for the account of the Contractor.

ARTICLE 6.04 MAINTENANCE AND GUARANTY

The Contractor hereby guarantees all the work furnished under this Contract against any defects in workmanship and materials for a period of one year following the date of final acceptance of the work by the City. Under this guarantee, the Contractor hereby agrees to make good, without delay, at his own expense, any failure of any part of the work due to faulty materials or manufacture, construction, or installation, or the failure of any equipment to perform satisfactorily all the work put upon it within the limits of the Contract Documents, and further, shall make good any damage to any part of the work caused by such failure. It is hereby agreed that the Performance Bond shall fully cover all guarantees contained in this Article.

It is also agreed that all warranties, expressed or implied, inure to the benefit of the City and are enforceable by the City.

SECTION 7 CHANGES

ARTICLE 7.01 MINOR CHANGES

The City reserves the right to make such additions, deductions, or changes to this Contract from time to time as

it deems necessary and in a manner not materially affecting the substance thereof or materially changing the price to be paid in order to carry out and complete more fully and perfectly the work herein agreed to be done and performed. This Contract shall in no way be invalidated by any such additions, deductions, or changes, and no claim by the Contractor shall be made for any loss of anticipated profits thereby.

Construction conditions may require that minor changes be made in the location and installation of the work and equipment to be furnished and other work to be performed hereunder, and the Contractor when ordered by the Engineer, shall make such adjustments and changes in said locations and work as may be necessary, without additional cost to the City, provided such adjustments and changes do not alter the character, quantity or cost of the work as a whole, and provided further that Plans and Specifications showing such adjustments and changes are furnished to the Contractor by the City within a reasonable time before any work involving such adjustment and changes is begun. The Engineer shall be the sole judge of what constitutes a minor change for which no additional compensation shall be allowed.

ARTICLE 7.02 EXTRA WORK

The City may at any time by a written order and without notice to the sureties require the performance of such extra work as it may find necessary or desirable. An order for extra work shall be valid only if issued in writing and signed by the Mayor and the work so ordered must be performed by the Contractor.

The amount of compensation to be paid to the Contractor for any extra work as so ordered shall be determined as follows:

(a) By such applicable unit prices, if any, as are set forth in the Proposal; or

(b) If no such unit prices are set forth then by a lump sum or other unit prices mutually agreed upon by the City and the Contractor; or

(c) If no such unit prices are set forth in the Proposal and if the parties cannot agree upon a lump sum or other unit prices then by the actual net cost in money to the Contractor of the extra work performed, which cost shall be determined as follows:

(1) For all labor and foreman in direct charge of the authorized operations, the Contractor shall receive the current local rate of wages to be agreed upon, in writing, before starting such work for each hour that said labor and foremen are actually engaged thereon, to which shall be added an amount equal to 25 percent of the sum thereof which shall be considered and accepted as full compensation for general supervision, FICA taxes, contributions under the Florida Unemployment Compensation Act, insurance, bond, subcontractor's profit and overhead, the furnishing of small tools and miscellaneous equipment used, such as picks, shovels, hand pumps, and similar items.

(2) For all materials used, the Contractor shall receive the actual cost of such materials delivered at the site or previously approved delivery point as established by original receipted bills. No percentage shall be added to this cost.

(3) For special equipment and machinery such as power-driven pumps, concrete mixers, trucks, and tractors, or other equipment, required for the economical performance of the authorized work, the Contractor shall receive payment based on the average local area rental price for each item of equipment and the actual time of its use on the work. No percentage shall be added to this sum.

(4) Records of extra work done under this procedure shall be reviewed at the end of each day by the Contractor or his representative and the Engineer. Duplicate copies of accepted records shall be made and signed by both Contractor or his representative and the Engineer, and one copy retained by each.

Request for payment for approved and duly authorized extra work shall be submitted in the same form as Contract work or in the case of work performed under paragraph (c) (1) above upon a certified statement supported by receipted bills. Such statement shall be submitted for the current Contract payment for the month in which the work was done.

ARTICLE 7.03 DISPUTED WORK

If the Contractor is of the opinion that any work required, necessitated, or ordered violates the terms and provisions of this Contract, he must promptly notify the Engineer, in writing, of his contentions with respect thereto and request a final determination thereof. If the Engineer determines that the work in question is Contract work and not extra work or that the order complained of is proper, he will direct the Contractor to proceed and the Contractor shall promptly comply. In order, however, to reserve his right to claim compensation for such work or damages resulting from such compliance, the Contractor must, within five (5) days after receiving notice of the Engineer's determination and direction, notify the City in writing that the work is being performed or that the determination and direction is being complied with under protest. Failure of the Contractor to notify shall be deemed as a waiver of claim for extra compensation or damages therefor.

Before final acceptance by the City, all matters of dispute must be adjusted to the mutual satisfaction of the parties thereto. Final determinations and decisions, in case any questions shall arise, shall constitute a condition precedent to the right of the Contractor to receive the money therefor until the matter in question has been adjusted.

ARTICLE 7.04 OMITTED WORK

The City may at any time by a written order and without notice to the sureties require the omission of such Contract work as it may find necessary or desirable.

An order for omission of work shall be valid only if signed by the Mayor and the work so ordered must be omitted by the Contractor. The amount by which the Contract price shall be reduced shall be determined as follows:

(a) By such applicable unit prices, if any, as are set forth in the Contract; or

(b) By the appropriate lump sum price set forth in the Contract; or

(c) By the fair and reasonable estimated cost to the City

of such omitted work as determined by the Engineer and approved by the City.

SECTION 8 CONTRACTOR'S EMPLOYEES

ARTICLE 8.01 CHARACTER AND COMPETENCY

The Contractor and his subcontractors shall employ upon all parts of the work herein contracted for only competent, skillful, and trustworthy workers. Should the Engineer at any time give notice, in writing, to the Contractor or his duly authorized representative on the work that any employee in his opinion is incompetent, unfaithful, disorderly, careless, unobservant of instructions, or in any way a detriment to the satisfactory progress of the work, such employee shall immediately be dismissed and not again allowed upon the site.

ARTICLE 8.02 SUPERINTENDENCE

The Contractor shall give his personal supervision to the faithful prosecution of the work and in case of his absence shall have a competent, experienced, and reliable supervisor or superintendent, acceptable to the Engineer on the site who shall follow without delay all instructions of the Engineer in the prosecution and completion of the work and every part thereof, in full authority to supply workers, material, and equipment immediately. He shall keep on hand at all times copies of the Contract Documents.

ARTICLE 8.03 EMPLOYMENT OPPORTUNITIES

The Contractor shall, in the performance of the work required to be done under this Contract, employ all workers without discrimination regarding race, creed, color, sex or national origin and must not maintain or provide facilities that are segregated on the basis of race, color, creed or national origin.

ARTICLE 8.04 RATES OF WAGES

On federally assisted projects, the rates of wages to be paid under this Contract shall not be less than the rates of wages set forth in Section 12 of this Agreement.

On other projects, no wage rate determination is included. Florida's Prevailing Wage Law (Section 215.19, Florida Statutes) was repealed effective April 25, 1979.

ARTICLE 8.05 PAYROLL REPORTS

The Contractor and each subcontractor shall, if requested to do so, furnish to the Engineer a duly certified copy of his payroll and also any other information required by the Engineer to satisfy him that the provisions of the law as to the hours of employment and rate of wages are being observed.

Payrolls shall be prepared in accordance with instructions furnished by the City and on approved forms. The Contractor shall not carry on his payroll any persons not employed by him. Subcontractor's employees shall be carried only on the payrolls of the employing subcontractor.

SECTION 9 CONTRACTOR'S DEFAULT

ARTICLE 9.01 CITY'S RIGHT AND NOTICE

It is mutually agreed that: (a) if the Contractor fails to begin work when required to do so, or (b) if at any time during the progress of the work it shall appear to the Engineer that the Contractor is not prosecuting the work with reasonable speed, or is delaying the work unreasonably and unnecessarily, or (c) if the force of workmen or quality or quantity of material furnished are not sufficient to insure completion of the work within the specified time and in accordance with the Specifications hereto attached, or (d) if the Contractor shall fail to make prompt payments for materials or labor or to subcontractors for work performed under the Contract, or (e) if legal proceedings have been instituted by others than the City in such manner as to interfere with the progress of the work and may subject the City to peril of litigation or outside claims of (f) if the Contractor shall be adjudged a bankrupt or make an assignment for the benefit of creditors, or (g) if in any proceeding instituted by or against the Contractor an order shall be made or entered granting an extension of time of payment, composition, adjustment, modification, settlement or satisfaction of his debts or liabilities, or (h) if a receiver or trustee shall be appointed for the Contractor or the Contractor's property, or (i) if the Contract or any part thereof shall be sublet without the consent of the City being first obtained in writing, or (j) if this Contract or any right, monies, or claim thereunder shall be assigned by the Contractor, otherwise than as herein specified, or (k) if the Contractor shall fail in any manner of substance to observe the provisions of this Contract, or (l) if any of the work, machinery, or equipment shall be defective, and shall not be replaced as herein provided, or (m) if the work to be done under this Contract shall be abandoned, then such fact or conditions shall be certified by the Engineer and thereupon the City without prejudice to any other rights or remedies of the City, shall have the right to declare the Contractor in default and so notify the Contractor by a written notice, setting forth the ground or grounds upon which such default is declared and the Contractor must discontinue the work, either as a portion of the work or the whole thereof, as directed.

ARTICLE 9.02 CONTRACTOR'S DUTY UPON DEFAULT

Upon receipt of notice that his Contract is in default, the Contractor shall immediately discontinue all further operations on the work or such part thereof, and shall immediately quit the site or such part thereof, leaving untouched all plant, materials, equipment, tools, and supplies.

ARTICLE 9.03 COMPLETION OF DEFAULTED WORK

The City, after declaring the Contractor in default, may then have the work completed or the defective equipment or machinery replaced or anything else done to complete the work in strict accordance with the Contract Documents by such means and in such manner, by Contract with or without public letting, or otherwise, as it may deem advisable,

utilizing for such purpose without additional cost to the City such of the Contractor's plant, materials, equipment, tools, and supplies remaining on the site, and also such subcontractors as it may deem advisable.

The City shall reimburse all parties, including itself, for the expense of such completion, including liquidated damages, if any, and the cost of reletting. The City shall deduct this expense from monies due or to become due to the Contractor under this Contract, or any part thereof, and in case such expense is more than the sum remaining unpaid of the original contract price, the Contractor and his sureties shall pay the amount of such deficiency to the City.

ARTICLE 9.04 PARTIAL DEFAULT

In case the City shall declare the Contractor in default as to a part of the work only, the Contractor shall discontinue such part, shall continue performing the remainder of the work in strict conformity with the terms of the Contract, and shall in no way hinder or interfere with any other contractor or person whom the City may engage to complete the work as to which the Contractor was declared in default.

SECTION 10 PAYMENTS

ARTICLE 10.01 PRICES

For the Contractor's complete performance of the work, the City will pay and the Contractor agrees to accept, subject to the terms and conditions hereof, the lump sum prices or unit prices in the Contractor's Proposal and the award made therein, plus the amount required to be paid for any extra work ordered under Article 7.02 hereof, less credit for any work omitted pursuant to Article 7.04 hereof. Under unit price items, the number of units actually required to complete the work under the Contract may be more than stated in the Proposal. The Contractor agrees that no claim will be made for any damages or for loss of profits because of a difference between the quantities of the various classes of work assumed and stated in the Proposal Form as a basis for comparing Proposals and the quantities of work actually performed.

The sum as awarded for any lump sum Contract or lump sum Contract Item shall represent payment in full for all of the various classes of work, including materials, equipment, and labor necessary or required to complete, in conformity with the Contract Document, the entire work shown, indicated or specified under the lump sum Contract or lump sum Contract Item.

The amount as awarded as a unit price for any unit price Contract Item shall represent payment in full for all the materials, equipment, and labor necessary to complete, in conformity with the Contract Documents, each unit of work shown, specified, or required under the said unit price Contract Item.

No payment other than the amount as awarded will be made for any class of work included in a lump sum Contract Item or a unit price Contract Item, unless specific provision is

made therefor in the Contract Documents.

ARTICLE 10.02 SUBMISSION OF BID BREAKDOWN

Within fifteen (15) days after the execution of this Contract, the Contractor must submit to the Engineer in duplicate an acceptable breakdown of the lump sums and unit prices bid for items of the Contract, showing the various operations to be performed under the Contract, as described in the progress schedule required under Article 4.02 hereof, and the value of each of such operations, the total of such items to equal the total price bid. The Contractor shall also submit such other information relating to the bid prices as may be required and shall revise the bid breakdown as directed. Thereafter, the breakdown may be used for checking the Contractor's applications for partial payments hereunder but shall not be binding upon the City or the Engineer for any purpose whatsoever.

ARTICLE 10.03 REPORTS, RECORDS AND DATA

The Contractor shall furnish to the Engineer such schedules of quantities and costs, progress schedules, reports, invoices, delivery tickets, estimates, records, and other data as the Engineer may request concerning work performed or to be performed and the materials furnished under the Contract.

ARTICLE 10.04 PAYMENTS BY CONTRACTOR

The Contractor shall pay (a) for all transportation and utility services not later than the 20th day of the calendar month following that in which such services are rendered, (b) for all materials, tools, and equipment delivered at the site of the project, and the balance of the cost thereof not later than the 30th day following the completion of that part of the work in or on which such materials, tools, and equipment are incorporated or used, and (c) to each of his subcontractors, not later than the 5th day following each payment to the Contractor, the respective amounts allowed the Contractor on account of the work performed by his subcontractors, to the extent of each subcontractor's interest therein; and proof of such payments or releases therefor shall be submitted to the Engineer upon request.

ARTICLE 10.05 PARTIAL PAYMENTS

On or about the first of each month, the Contractor shall make and certify an estimate, on forms prescribed by the City, of the amount and fair value of the work done, and may apply for partial payment therefor. The Contractor shall revise the estimate as the Engineer may direct. When satisfactory progress has been made, and shows that the value of the work completed since the last payment exceeds one percent (1%) of the total Contract price in amount, the Engineer will issue a certificate that such work has been completed and the value thereof. The City will then issue a voucher to the Contractor in accordance with the following schedule:

FOR CONTRACT AMOUNTS UNDER \$250,000

(A) In the amount of ninety percent (90%) of the value of the work completed as certified until construction is one hundred percent (100%) complete (operational or beneficial occupancy), the withheld amount may be reduced below ten percent (10%), at the Engineer's option, to only that amount necessary to assure completion.

FOR CONTRACT AMOUNTS OVER \$250,000

(A) In the amount of ninety percent (90%) of the value of the work completed as certified until construction is fifty percent (50%) complete.

(B) When the dollar value, as determined by the Engineer, of satisfactorily completed work in place is greater than fifty percent (50%) of the original contract price, vouchers for partial payment will be issued by the City to the Contractor in the amount of one hundred percent (100%) of the value of the work, above 50%, completed as certified for that payment period.

(C) If the Contractor has performed satisfactorily and the work is substantially complete (operational or beneficial occupancy) the withheld amount may be reduced, at the Engineer's option, to only that amount necessary to assure completion.

In addition to the Conditions set forth in (A), (B), and (C) above, payments will always be less any sums that may be retained or deducted by the City under the terms of any of the contract documents and less any sums that may be retained to cover monetary guarantees for equipment, materials or progress performance.

Payment on estimates made on or about the first of the month may be expected on or about the 20th of the month.

Unless specified otherwise in the Contract Items, the delivered cost of equipment and nonperishable materials suitably stored at the site of the work and tested for adequacy may be included in the Contractor's application for partial payment provided, however, that the Contractor shall furnish evidence satisfactory to the City that the Contractor is the unconditional owner and in possession of such materials or equipment. The amount to be paid will be 90 percent of the invoice cost to the Contractor which cost shall be supported by receipted bills within 30 days of the date of payment by the City to the Contractor. Such payment shall not relieve the Contractor from full responsibility for completion of the work and for protection of such materials and equipment until incorporated in the work in a permanent manner as required by the Contract Documents.

Before any payment will be made under this Contract, the Contractor and every subcontractor, if required, shall deliver to the Engineer a written, verified statement, in satisfactory form, showing in detail all amounts then due and unpaid by such Contractor or subcontractor to all laborers, workmen, and mechanics, employed by him under the Contract for the performance of the work at the site thereof, for daily or weekly wages, or to other persons for materials, equipment, or supplies delivered at the site of the work during the period covered by the payment under consideration.

ARTICLE 10.06 FINAL PAYMENT

Under determination of satisfactory completion of the work under this Contract as provided in Article 4.07 hereof, the Engineer will prepare the final estimate showing the value of the completed work. This estimate will be prepared within 30 days after the date of completion or as soon thereafter as the necessary measurements and computations can be made.

All prior certificates and estimates, being approximate only, are subject to correction in the final estimate and payment.

When the final estimate has been prepared and certified by Engineer, he will submit to the Mayor and City Council the final certificate stating that the work has been completed and the amount based on the final estimate remaining due to the Contractor. The City will then accept the work as fully completed and will, not later than 30 days after the final acceptance, as defined in Article 1.02, of the work done under this Contract, pay the Contractor the entire amount so found due thereunder after deduction of all previous payments and all percentages and amounts to be kept and retained under provisions of this Contract; provided, however, and it is understood and agreed that, as a precedent to receiving final payment, the Contractor shall submit to the City a sworn affidavit that all bills for labor, service, materials, and subcontractors have been paid and that there are no suits pending in connection with this work. The City, at its option, may permit the Contractor to execute a separate surety bond in a form satisfactory to the City. The surety bond shall be in the full amount of the suit or suits.

Neither the final payment nor any part of the retained percentage shall be paid until the Contractor, if required, shall furnish the City with a complete release from any should remain unsatisfied after all payments are made, the Contractor shall refund to the City all monies which the City may be compelled to pay in discharging such claim, including incidental costs and attorney's fees.

ARTICLE 10.07 ACCEPTANCE OF FINAL PAYMENT

The acceptance by the Contractor, or by anyone claiming by or through him, of the final payment shall operate as and shall be a release to the City and every officer and agent thereof from any and all claims and liability to the Contractor for anything done or furnished in connection with the work or project and for any act or neglect of the Contractor or of any others relating to or affecting the work. No payment, however, final or otherwise, shall operate to release the Contractor or his sureties from any obligations under this Contract or the Performance Bond.

SECTION 11 MISCELLANEOUS PROVISIONS

ARTICLE 11.01 CONTRACTOR'S WARRANTIES

In consideration of, and to induce the award of this contract to him, the Contractor represents and warrants:

(a) That he is not in arrears to the City upon debt or contract, and he is not a defaulter, as surety, contractor, or otherwise.

(b) That he is financially solvent and sufficiently experienced and competent to perform the work.

(c) That the work can be performed as called for by the Contract Documents.

(d) That the facts stated in his proposal and the information given by him are true and correct in all respects.

(e) That he is fully informed regarding all the conditions affecting the work to be done and labor and materials to be

furnished for the completion of this Contract, and that his information was secured by personal investigation and research.

ARTICLE 11.02 PATENTED DEVICES, MATERIAL AND PROCESSES

It is mutually understood and agreed that Contract prices include all royalties and costs arising from patents, trademarks, and copyrights in any way involved in the work. Whenever the Contractor is required or desires to use any design, device, material, or process covered by letters of patent or copyright, the Contractor shall indemnify and save harmless the City, its officers, agents and employees from any and all claims for infringement by reason of the use of any such patented design, device, tool, material, equipment, or process, to be performed under the Contract, and shall indemnify the said City, its officers, agents, and employees for any costs, expenses, and damages which may be incurred by reason of such infringement at any time during the prosecution or after completion of the work.

ARTICLE 11.03 SUITS AT LAW

In case any action at law or suit in equity may or shall be brought against the City or any of its officers, agents, or employees for or on account of the failure, omission, or neglect of the Contractor or his subcontractors, employees, or agents, to do or perform any of the covenants, acts, matters, or things by this Contract undertaken to be done or performed by the Contractor or his subcontractors, employees, or agents, or from any injuries done to property or persons and caused by the negligence or alleged negligence of the Contractor or his subcontractors, employees, or agents, or in any other manner arising out of the performance of this Contract, then the Contractor shall immediately assume and take charge of the defense of such actions or suits in like manner and to all intents and purposes as if said actions or suits have been brought directly against the Contractor, and the Contractor shall also indemnify and save harmless the City, its officers, agents, and employees from any and all loss, cost or damage whatever arising out of such actions or suits, in like manner and to all intents and purposes as if said actions or suits have been brought directly against the Contractor.

The Contractor shall and does hereby assume all liability for and agrees to indemnify the City or its Engineer against any or all loss, costs, damages, and liability for any or by reason of any lien, claims or demands, either for materials purchased or for work performed by laborers, mechanics, and others and from any damages, costs, actions, or causes of action and judgement arising from injuries sustained by mechanics, laborers, or other persons by reason of accidents or otherwise, whether caused by the carelessness or inefficiency or neglect of said Contractor, his subcontractors, agents, employees, workmen or otherwise.

ARTICLE 11.04 CLAIMS FOR DAMAGES

If the Contractor shall claim compensation for any damage sustained, other than for extra or disputed work covered by Article 7.02 and 7.03 hereof, by reason of any act or omission of the City, its agents, or any persons, he shall, within five days after sustaining such damage, make and

deliver to the Engineer a written statement of the nature of the damage sustained and of the basis of the claim against the City. On or before the 15th of the month succeeding that in which any damage shall have been sustained, the Contractor shall make and deliver to the Engineer an itemized statement of the details and amounts of such damage, duly verified by the Contractor. Unless such statements shall be made delivered within the times aforesaid, it is stipulated that and all claims for such compensation shall be forfeited and invalidated, and the Contractor shall not be entitled to payment on account of such claims.

ARTICLE 11.05 NO CLAIMS AGAINST INDIVIDUALS

No claim whatsoever shall be made by the Contractor against any officer, agent, employee of the City for, or on account of, anything done or omitted to be done in connection with this Contract.

ARTICLE 11.06 LIABILITY UNAFFECTED

Nothing herein contained shall in any manner create any liability against the City on behalf of any claim for labor, services, or materials, or of subcontractors, and nothing herein contained shall affect the liability of the Contractor or his sureties to the City or to any workmen or materialsmen upon bond given in connection with this Contract.

ARTICLE 11.07 INDEMNIFICATION PROVISIONS

Whenever there appears in this Agreement, or in the other Contract Documents made a part hereof, an indemnification provision within the purview of Chapter 725.06, Laws of Florida, the monetary limitation on the extent of the indemnification under each such provision shall be One Million Dollars or a sum equal to the total Contract price, whichever shall be the greater.

ARTICLE 11.08 UNLAWFUL PROVISIONS DEEMED STRICKEN

If this contract contains any unlawful provisions not an essential part of the Contract and which shall not appear to have a controlling or material inducement to the making thereof, such provisions shall be deemed of no effect and shall, upon notice by either party, be deemed stricken from the Contract without affecting the binding force of the remainder.

ARTICLE 11.09 LEGAL PROVISIONS DEEMED INCLUDED

Each and every provision of any law and clause required by law to be inserted in this Contract shall be deemed to be inserted herein, and the Contract shall be read and enforced as though it were included herein and if, through mistake or otherwise, any such provision is not inserted or is not correctly inserted, then upon application of either party the Contract shall forthwith be physically amended to make such insertion.

ARTICLE 11.10 DEATH OR INCOMPETENCY OF CONTRACTOR

In the event of death or legal incompetency of a Contractor who shall be an individual or surviving member of a contracting firm, such death or adjudication of incompetency

shall not terminate the Contract, but shall act as default hereunder to the effect provided in Article 9.01 hereof and the estate of the Contractor and his surety shall remain liable hereunder to the same extent as though the Contractor had lived. Notice of default, as provided in Article 9.01 hereof, shall not be required to be given in the event of such death or adjudication of incompetency.

ARTICLE 11.11 NUMBER AND GENDER OF WORDS

Whenever the context so admits or requires, all references herein in one number shall be deemed extended to and including the other number, whether singular or plural, and the use of any gender shall be applicable to all genders.

ARTICLE 11.12 ACCESS TO RECORDS

Representatives of Federal Agencies, if applicable, and the State of Florida shall have access to the work whenever it is in preparation of progress. On federally assisted projects the Federal Agency, the Comptroller General of the United States, or any authorized representative shall have access to any books, documents, papers, and records of the Contractor which are pertinent to the project for the purpose of making audit, examination, excerpts, and transcription thereof.

**SECTION 12
LABOR STANDARDS**

ARTICLE 12.01 LABOR STANDARDS

The Contractor shall comply with all of the regulations set forth in "Labor Standards Provisions for Federally Assisted Construction Contracts", which may be attached, and any applicable Florida Statutes.

ARTICLE 12.02 NOTICE TO LABOR UNIONS

If required, the Contractor shall provide Labor Unions and other organizations of workers, and shall post, in a conspicuous place available to employees or applicants for employment, a completed copy of the form entitled "Notice to Labor Unions or Other Organizations of Workers" attached to and made a part of this Agreement.

ARTICLE 12.03 SAFETY AND HEALTH REGULATIONS

The Contractor shall comply with the Department of Labor Safety and Health Regulations for construction promulgated under the Occupational Safety and Health Act of 1970 (PL 91- 596) and under Section 107 of the Contract Work Hours and Safety Standards Act (PL 91-54). Nothing in these Acts shall be construed to supersede or in any manner affect any worker's compensation law or statutory rights, duties, or liabilities of employers and employees under any law with respect to injuries, diseases, or death of employees arising out of, or in the course of, employment.

ARTICLE 12.04 EEO AFFIRMATIVE ACTION REQUIREMENTS

The Contractor understands and agrees to be bound by the equal opportunity requirements of Federal regulations which shall be applicable throughout the performance of work under this Contract. The Contractor also agrees to similarly

bind contractually each subcontractor. In policies, the Contractor agrees to engage in Affirmative Action directed at promoting and ensuring equal employment opportunity in the work force used under the Contract (and the Contractor agrees to require contractually the same effort of all subcontractors whose subcontractors exceed \$100,000). The Contractor understands and agrees that "Affirmative Action" as used herein shall constitute a good faith effort to achieve and maintain minority employment in each trade in the on-site work force used on the Contract.

ARTICLE 12.05 PREVAILING RATES OF WAGES

Florida's prevailing wage law was repealed effective April 25, 1979.

For Federally assisted projects, appropriate prevailing wage rate determinations are indicated on pages beginning with WR-1.

* * * * *

IN WITNESS THEREOF, the parties have hereunto set their hands and seals, and such of them as are corporation have caused these present to be signed by their duly authorized officers.

CITY OF TAMPA, FLORIDA

Bob Buckhorn, Mayor
(SEAL)

ATTEST:

City Clerk

Approved as to Form:
The execution of this document was authorized
by Resolution No. _____

Rachel S. Peterkin, Assistant City Attorney

Contractor

By: _____
(SEAL)

Title:

ATTEST:

Witness

TAMPA AGREEMENT (ACKNOWLEDGMENT OF PRINCIPAL)

STATE OF _____)
) SS:
COUNTY OF _____)

For a Corporation:

STATE OF _____
COUNTY OF _____

The foregoing instrument was acknowledged before me this ____ of _____, 20__ by _____ of _____, a _____ corporation, on behalf of the corporation. He/she is ____ personally known or has ____ produced _____ as identification.

Notary

My Commission Expires:

For an Individual:

STATE OF _____
COUNTY OF _____

The foregoing instrument was acknowledged before me this ____ of _____, 20__ by _____ who is ____ personally known to me or has ____ produced _____ as identification.

Notary

My Commission Expires:

For a Firm:

STATE OF _____
COUNTY OF _____

The foregoing instrument was acknowledged before me this ____ of _____, 20__ by _____ who signed on behalf of the said firm. He/she is ____ personally known or has ____ produced _____ as identification.

Notary

My Commission Expires:

PUBLIC CONSTRUCTION BOND

Bond No. (enter bond number) _____

Name of Contractor: _____

Principal Business Address of Contractor: _____

Telephone Number of Contractor: _____

Name of Surety (if more than one list each): _____

Principal Business Address of Surety: _____

Telephone Number of Surety: _____

Owner is The City of Tampa, Florida

Principal Business Address of Owner: _____ 306 E Jackson St, Tampa, FL 33602

_____ Contract Administration Department (280A4N)

Telephone Number of Owner: _____ 813/274-8456

Contract Number Assigned by City to contract which is the subject of this bond: _____

Legal Description or Address of Property Improved or Contract Number is: _____

General Description of Work and Services: _____

KNOW ALL MEN BY THESE PRESENTS That we, _____

(Name of Contractor)

as Principal, hereinafter called CONTRACTOR, of the State of _____, and

(Name of Surety)

a corporation organized and existing under and by virtue of the laws of the State of _____, and regularly authorized to do business in the State of Florida, as SURETY, are held and firmly bound unto the City of Tampa, a municipal corporation organized and existing under the laws of the State of Florida, hereinafter called Owner, in the penal sum of _____ Dollars and _____ Cents (\$ _____), lawful money of the United States of America, for the payment whereof well and truly to be made, we bind ourselves, our heirs, executors, and administrators, successors and assigns, jointly and severally, firmly by these presents.

THE CONDITION OF THIS BOND is that if Principal:

1. Performs the contract dated _____, _____, 20____, between Principal and Owner for construction of _____, the contract being made a part of this bond by reference, in the time and in the manner prescribed in the contract; and
2. Promptly makes payments to all claimants, as defined in Section 255.05(1) (Section 713.01), Florida Statutes, supplying Principal with labor, materials, or supplies, used directly or indirectly by Principal in the prosecution of the work provided for in the contract; and
3. Pays Owner all losses, damages, expenses, costs, and attorney's fees, including appellate proceedings, that Owner sustains because of a default by Principal under the contract; and
4. Performs the guarantee of all work and materials furnished under the contract for the time specified in the contract, then this bond is void; otherwise it remains in full force.
5. Contractor and Surety acknowledge that the Work for which this bond has been issued may be one of several such contract documents for a group of projects. This bond does not secure covenants to pay for or to perform design services survey or program management services. The Owner/Obligee is expected to reasonably account for damages that are caused to Owner with respect to Principal's (Contractor's) default in performance of the scope of the Work incorporated by reference into the bond, and notwithstanding any contractual or common law remedy permitted to Owner as against Contractor, the obligation of Surety for any damages under this bond shall be determined by the cost of completion of the Work less the contract balance unpaid upon default of Contractor for the Work plus liquidated damages at the rate of \$500.00 per day for delays by the Contractor and/or Surety in reaching substantial completion.
6. The notice requirements for claimants and conditions for entitlement to payment set forth in Section 255.05, Fla. Stat. and the limitations period to actions upon Section 255.05, Fla. Stat. bonds apply to claimants seeking payment from surety under this bond. Any action instituted by a claimant under this bond for payment must be in accordance with the notice and time limitation provisions in Section 255.05, Florida Statutes.
7. The Surety, for value received, hereby stipulates and agrees that no changes, extensions of time, alterations or additions to the terms of the contract documents or other Work to be performed hereunder, or the specifications referred to therein shall in any way affect its obligations under this bond, and it does hereby waive notice of any such changes, extensions of time, alterations or additions to the terms of the Contract or to Work or to the specifications.

8. The above SURETY states that it has read all of the Contract Documents made by the CONTRACTOR with the CITY, hereto attached, and the terms and conditions of the contract and work, and is familiar therewith and in particular those portions of the Agreement concerning the guaranty of such CONTRACTOR for a period of one year following the date of the final acceptance of the completed work under the Contract by the CITY, all of which this BOND includes.

DATED ON _____, 20__

(Name of Principal)

(Name of Surety)

(Principal Business Address)

(Surety Address)

By _____

By _____
(As Attorney in Fact)*

Title _____

Telephone Number of Surety

Telephone Number of Principal

Approved as to legal sufficiency:

Countersignature:

By _____
Assistant City Attorney

(Name of Local Agency)

(Address of Resident Agent)

By _____

Title _____

Telephone Number of Local Agency

*(As Attorney in Fact) attach Power of Attorney and Current Certificate with Original Signature

SPECIFICATIONS GENERAL PROVISIONS

SECTION 1 SCOPE AND INTENT

G-1.01 DESCRIPTION

The work to be done consists of the furnishing of all labor, materials and equipment, and the performance of all work included in this Contract.

G-1.02 WORK INCLUDED

The Contractor shall furnish all labor, superintendence, materials, plant, power, light, heat, fuel, water, tools, appliances, equipment, supplies, and other means of construction necessary or proper for performing and completing the work. He shall obtain and pay for all required permits. He shall perform and complete the work in the manner best calculated to promote rapid construction consistent with safety of life and property and to the satisfaction of the Engineer, and in strict accordance with the Contract Documents. The Contractor shall clean up the work and maintain it during and after construction, until accepted, and shall do all work and pay all costs incidental thereto. He shall repair or restore all structures and property that may be damaged or disturbed during performance of the work.

The cost of incidental work described in these General Provisions, for which there are no specific Contract Items, shall be considered as part of the overhead cost of doing the work and shall be included in the prices for the various Contract Items. No additional payment will be made therefor.

The Contractor shall provide and maintain such modern plant, tools, and equipment as may be necessary, in the opinion of the Engineer, to perform in a satisfactory and acceptable manner all the work required by this Contract. Only equipment of established reputation and proven efficiency shall be used. The Contractor shall be solely responsible for the adequacy of his plant and equipment, prior approval of the Engineer notwithstanding.

G-1.03 PUBLIC UTILITY INSTALLATIONS AND STRUCTURES

Public utility installations and structures shall be understood to include all poles, tracks, pipes, wires, conduits, house service connections, vaults, manholes, and all other appurtenances and facilities pertaining thereto whether owned or controlled by the City, other governmental bodies or privately owned by individuals, firms, or corporations, and used to serve the public with transportation, traffic control, gas, electricity, telephone, sewerage, drainage, water or other public or private property which may be affected by the work.

The Contract Documents contain data relative to existing public utility installations and structures above and below the ground surface. These data are not guaranteed as to their completeness or accuracy and it is the responsibility of the Contractor to make his own investigations to inform himself

fully of the character, condition and extent of all such installations and structures as may be encountered and as may affect the construction operations.

The Contractor shall protect all public utility installations and structures from damage during the work. Access across any buried public utility installation or structure shall be made only in such locations and by means approved by the Engineer. The Contractor shall so arrange his operations as to avoid any damage to these facilities. All required protective devices and construction shall be provided by the Contractor at his expense. All existing public utilities damaged by the Contractor which are shown on the Plans or have been located in the field by the utility shall be repaired by the Contractor, at his expense, as directed by the Engineer. No separate payment shall be made for such protection or repairs to public utility installations or structures.

Public utility installations or structures owned or controlled by the City or other governmental body which are shown on the Plans to be removed, relocated, replaced or rebuilt by the Contractor shall be considered as a part of the general cost of doing the work and shall be included in the prices bid for the various Contract Items. No separate payment shall be made therefor.

Where public utility installations or structures owned or controlled by the City or other governmental body are encountered during the course of the work, and are not indicated on the Plans or in the Specifications, and when, in the opinion of the Engineer, removal, relocation, replacement or rebuilding is necessary to complete the work under this Contract, such work shall be accomplished by the utility having jurisdiction or such work may be ordered, in writing by the Engineer, for the Contractor to accomplish. If such work is accomplished by the utility having jurisdiction it will be carried out expeditiously and the Contractor shall give full cooperation to permit the utility to complete the removal, relocation, replacement or rebuilding as required. If such work is accomplished by the Contractor, it will be paid for as extra work as provided for in Article 7.02 of the Agreement.

The Contractor shall, at all times in performance of the work, employ approved methods and exercise reasonable care and skill so as to avoid unnecessary delay, injury, damage or destruction of public utility installations and structures; and shall, at all times in the performance of the work, avoid unnecessary interference with, or interruption of, public utility services, and shall cooperate fully with the owners thereof to that end.

All City and other governmental utility departments and other owners of public utilities, which may be affected by the work, will be informed in writing by the Engineer within two weeks after the execution of the Contract or Contracts covering the work. Such notice will set out, in general, and direct attention to, the responsibilities of the City and other governmental

utility departments and other owners of public utilities for such installations and structures as may be affected by the work and will be accompanied by one set of Plans and Specifications covering the work under such Contract or Contracts.

In addition to the general notice given by the Engineer, the Contractor shall give written notice to all City and other governmental utility departments and other owners of public utilities of the location of his proposed construction operations, at least forty-eight (48) hours in advance of breaking ground in any area or on any unit of the work. This can be accomplished by making the appropriate contact with the "Underground Utility Notification Center for Excavators (Call Candy)".

The maintenance, repair, removal, relocation, or rebuilding of public utility installations and structures, when accomplished by the Contractor as herein provided, shall be done by methods approved by the Engineer.

SECTION 2 PLANS AND SPECIFICATIONS

G-2.01 PLANS

The Plans referred to in the Contract Documents bear the general project name and number as shown in the Notice To Bidders.

When obtaining data and information from the Plans, figures shall be used in preference to scaled dimensions, and large scale drawings in preference to small scale drawings.

G-2.02 COPIES FURNISHED TO CONTRACTOR

After the Contract has been executed, the Contractor will be furnished with five sets of paper prints, the same size as the original drawings, of each sheet of the Plans and five copies of the Specifications. Additional copies of the Plans and Specifications, when requested, may be furnished to the Contractor at cost of reproduction.

The Contractor shall furnish each of the subcontractors, manufacturers, and material suppliers such copies of the Contract Documents as may be required for his work.

G-2.03 SUPPLEMENTARY DRAWINGS

When, in the opinion of the Engineer, it becomes necessary to explain more fully the work to be done or to illustrate the work further or to show any changes which may be required, drawings known as Supplementary Drawings, with specifications pertaining thereto, will be prepared by the Engineer and five paper prints thereof will be given to the Contractor.

The Supplementary Drawings shall be binding upon the Contractor with the same force as the Plans. Where such Supplementary Drawings require either less or more than the estimated quantities of work, credit to the City or compensation therefor to the Contractor shall be subject to the terms of the Agreement.

G-2.04 CONTRACTOR TO CHECK PLANS AND DATA

The Contractor shall verify all dimensions, quantities, and details shown on the Plans, Supplementary Drawings, Schedules, Specifications, or other data received from the Engineer, and shall notify him of all errors, omissions, conflicts, and discrepancies found therein. Failure to discover or correct errors, conflicts or discrepancies shall not relieve the Contractor of full responsibility for unsatisfactory work, faulty construction or improper operation resulting therefrom nor from rectifying such conditions at his own expense. He will not be allowed to take advantage of any errors or omissions as full instructions will be furnished by the Engineer, should such errors or omissions be discovered. All schedules are given for the convenience of the Engineer and the Contractor and are not guaranteed to be complete. The Contractor shall assume all responsibility for the making of estimates of the size, kind, and quality of materials and equipment included in work to be done under the Contract.

G-2.05 SPECIFICATIONS

The specifications consist of four parts, the General Provisions, the Technical Specifications, the Special Provisions and the Contract Items. The General Provisions and Technical Specifications contain general requirements which govern the work. The Special Provisions and the Contract Items modify and supplement these by detailed requirements for the work and shall always govern, whenever there appears to be conflict.

G-2.06 INTENT

All work called for in the Specifications applicable to this Contract, but not shown on the Plans in their present form, or vice versa, shall be of like effect as if shown or mentioned in both. Work not specified in either the Plans or in the Specifications, but involved in carrying out their intent or in the complete and proper execution of the work, is required and shall be performed by the Contractor as though it were specifically delineated or described.

The apparent silence of the Specifications as to any detail, or the apparent omission from them of a detailed description concerning any work to be done and materials to be furnished, shall be regarded as meaning that only the best general practice is to prevail and that only material and workmanship of the best quality is to be used, and interpretation of these Specifications shall be made upon that basis.

SECTION 3 WORKING DRAWINGS

G-3.01 SCOPE

The Contractor shall promptly prepare and submit layout, detail and shop drawings to insure proper construction, assembly, and installation of the work using those materials and methods as hereafter specified under the Technical Specifications, Special Provisions and Contract Items.

These drawings shall accurately and distinctly present the following:

- a. All working and erection dimensions.
- b. Arrangements and sectional views.
- c. Necessary details, including complete information for making connections between work under this Contract and work under other Contracts.
- d. Kinds of materials and finishes.
- e. Parts listed and description thereof.

Drawings for mechanical equipment shall present, where applicable, such data as dimensions, weight and performance characteristics. These data shall show conformance with the performance characteristics and other criteria incorporated in the Plans and Specifications.

Each drawing shall be dated and shall contain the name of the project, Division number and description, the technical specifications section number, names of equipment or materials and the location at which the equipment or materials are to be installed. Location shall mean both physical location and location relative to other connected or attached material. The Engineer will return unchecked any submittal which does not contain complete data on the work and full information on related matters.

Stock or standard drawings will not be accepted for review unless full identification and supplementary information is shown thereon in ink or typewritten form.

The Contractor shall review all working drawing submittals before transmitting them to the Engineer to determine that they comply with requirements of the Specifications. Drawings which are incomplete or are not in compliance with the Contract Documents shall not be submitted for processing by the Engineer. The Contractor shall place his stamp of approval on all working drawings submitted to the Engineer to indicate compliance with the above.

G-3.02 APPROVAL

If the working drawings show departures from the Contract requirements, the Contractor shall make specific mention thereof in his letter of submittal; otherwise approval of such submittals shall not constitute approval of the departure. Approval of the drawings shall constitute approval of the subject matter thereof only and not of any structure, material, equipment, or apparatus shown or indicated.

The approval of drawings will be general and shall not relieve the Contractor of responsibility for the accuracy of such drawings, nor for the proper fitting and construction of the work, nor for the furnishing of materials or work required by the Contract and not indicated on the drawings. No work called for by working drawings shall be done until such drawings have been approved by the Engineer.

The procedure in seeking approval of the working drawings shall be as follows:

1. The Contractor shall submit four complete sets of drawings

and other descriptive data together with one copy of a letter of transmittal to the Engineer for approval. The letter of transmittal shall contain the name of the project, contract number, technical specifications section number, the name of the Contractor, a list of drawings with numbers and titles, and any other pertinent information.

2. Drawings or descriptive data will be stamped "Approved", "Approved Subject to Corrections Marked", or "Examined and Returned for Correction" and one copy with a letter of transmittal will be returned to the Contractor.

3. If a drawing or other data is stamped "Approved", the Contractor shall insert the date of approval on five additional copies of the document and transmit the five copies to the Engineer together with one copy of a letter of transmittal containing substantially the same information as described in Instruction 1. above.

4. If a drawing or other data is stamped "Approved Subject to Corrections Marked", the Contractor shall make the corrections indicated and proceed as in Instruction 3., above.

5. If a drawing or data is stamped "Examined and Returned for Correction", the Contractor shall make the necessary corrections and resubmit the documents as set forth in Instruction 1., above. The letter of transmittal shall indicate that this is a resubmittal.

The Contractor shall revise and resubmit the working drawings as required by the Engineer, until approval thereof is obtained.

SECTION 4 MATERIALS AND EQUIPMENT

G-4.01 GENERAL REQUIREMENTS

All materials, appliances, and types or methods of construction shall be in accordance with the Specifications and shall, in no event, be less than that necessary to conform to the requirements of any applicable laws, ordinances, and codes.

All materials and equipment shall be new, unused, and correctly designed. They shall be of standard first grade quality, produced by expert personnel, and intended for the use for which they are offered. Materials or equipment which, in the opinion of the Engineer, are inferior or of a lower grade than indicated, specified, or required will not be accepted.

The quality of Workmanship and Materials entering into the work under this Contract shall conform to the requirements of the pertinent sections, clauses, paragraphs, and sentences, both directly and indirectly applicable thereto, of that part of the Technical Specifications, whether or not direct reference to such occurs in the Contract Items.

Equipment and appurtenances shall be designed in conformity with ANSI, ASME, IEEE, NEMA and other

generally accepted standards and shall be of rugged construction and of sufficient strength to withstand all stresses which may occur during fabrication, testing, transportation, installation, and all conditions of operation. All bearings and moving parts shall be adequately protected against wear by bushings or other approved means and shall be fully lubricated by readily accessible devices. Details shall be designed for appearance as well as utility. Protruding members, joints, corners, gear covers, and the like, shall be finished in appearance. All exposed welds shall be ground smooth and the corners of structural shapes shall be mitered.

Equipment shall be of the approximate dimensions as indicated on the Plans or as specified, shall fit the spaces shown on the Plans with adequate clearances, and shall be capable of being handled through openings provided in the structure for this purpose. The equipment shall be of such design that piping and electrical connections, ductwork, and auxiliary equipment can be assembled and installed without causing major revisions to the location or arrangement of any of the facilities.

Machinery parts shall conform exactly to the dimensions shown on the working drawings. There shall be no more fitting or adjusting in setting up a machine than is necessary in assembling high grade apparatus of standard design. The equivalent parts of identical machines shall be made interchangeable. All grease lubricating fittings on equipment shall be of a uniform type. All machinery and equipment shall be safeguarded in accordance with the safety codes of the ANSI and applicable state and local codes.

G-4.02 MANUFACTURER

The names of proposed manufacturers, suppliers, material, and dealers who are to furnish materials, fixtures, equipment, appliances or other fittings shall be submitted to the Engineer for approval, as early as possible, to afford proper investigation and checking. Such approval must be obtained before shop drawings will be checked. No manufacturer will be approved for any materials to be furnished under this Contract unless he shall be of good reputation and have a plant of ample capacity. He shall, upon the request of the Engineer, be required to submit evidence that he has manufactured a similar product to the one specified and that it has been previously used for a like purpose for a sufficient length of time to demonstrate its satisfactory performance.

All transactions with the manufacturers or subcontractors shall be through the Contractor, unless the Contractor shall request, in writing to the Engineer, that the manufacturer or subcontractor deal directly with the Engineer. Any such transactions shall not in any way release the Contractor from his full responsibility under this Contract.

Any two or more pieces of material or equipment of the same kind, type or classification, and being used for identical types of service, shall be made by the same manufacturer.

G-4.03 REFERENCE TO STANDARDS

Whenever reference is made to the furnishing of materials or

testing thereof to conform to the standards of any technical society, organization or body, it shall be construed to mean the latest standard, code, specification or tentative specification adopted and published at the date of advertisement for proposals, even though reference has been made to an earlier standard, and such standards are made a part hereof to the extent which is indicated or intended.

Reference to a technical society, organization or body may be made in the Specifications by abbreviations, in accordance with the following list:

AASHTO for American Association of State Highway and Transportation Officials (formerly AASHO)
ACI for American Concrete Institute
AGMA for American Gear Manufacturer's Association
AFBMA for Anti-Friction Bearing Manufacturer's Association
AISC for American Institute of Steel Construction
AISI for American Iron and Steel Institute
ANSI for American National Standards Institute
ASCE for American Society of Civil Engineers
ASTM for American Society for Testing and Materials
ASME for American Society of Mechanical Engineers
AWS for American Welding Society
AWWA for American Water Works Association
AWPA for American Wood Preservers Association
CEMA for Conveyor Equipment Manufacturers Association
CIPRA for Cast Iron Pipe Research Association
IEEE for Institute of Electrical and Electronic Engineers
IPCEA for Insulated Power Cable Engineers Association
NEC for National Electrical Code
NEMA for National Electrical Manufacturers Association
SAE for Society of Automotive Engineers
SHBI for Steel Heating Boiler Institute
Fed.Spec. for Federal Specifications
Navy Spec. for Navy Department Specifications
U.L.,Inc. for Underwriters' Laboratories, Inc.

When no reference is made to a code, standard or specification, the Standard Specifications of the ANSI, the ASME, the ASTM, the IEEE, or the NEMA shall govern.

G-4.04 SAMPLES

The Contractor shall, when required, submit to the Engineer for approval typical samples of materials and equipment. The samples shall be properly identified by tags and shall be submitted sufficiently in advance of the time when they are to be incorporated into the work, so that rejections thereof will not cause delay. A letter of transmittal, in duplicate, from the Contractor requesting approval must accompany all such samples.

G-4.05 EQUIVALENT QUALITY

Whenever, in the Contract Documents, an article, material, apparatus, equipment, or process is called for by trade name or by the name of a patentee, manufacturer, or dealer or by reference to catalogs of a manufacturer or dealer, it shall be understood as intending to mean and specify the article, material, apparatus, equipment or process designated, or any

equal thereto in quality, finish, design, efficiency, and durability and equally serviceable for the purposes for which it is intended.

Whenever material or equipment is submitted for approval as being equal to that specified, the decision as to whether or not such material or equipment is equal to that specified shall be made by the Engineer.

Upon rejection of any material or equipment submitted as the equivalent of that specifically named in the Contract, the Contractor shall immediately proceed to furnish the designated material or equipment.

Neither the approval by the Engineer of alternate material or equipment as being equivalent to that specified nor the furnishing of the material or equipment specified, shall in any way relieve the Contractor of responsibility for failure of the material or equipment, due to faulty design, material, or workmanship, to perform the functions required of them by the Specifications.

G-4.06 DELIVERY

The Contractor shall deliver materials in ample quantities to insure the most speedy and uninterrupted progress of the work so as to complete the work within the allotted time. The Contractor shall also coordinate deliveries in order to avoid a delay in, or impediment of, the progress of the work of any related Contractor.

G-4.07 CARE AND PROTECTION

The Contractor shall be solely responsible for properly storing and protecting all materials, equipment, and work furnished under the Contract from the time such materials and equipment are delivered at the site of the work until final acceptance thereof. He shall, at all times, take necessary precautions to prevent injury or damage by water, freezing, or by inclemencies of the weather to such materials, equipment and work. All injury or damage to materials, equipment, or work resulting from any cause whatsoever shall be made good by the Contractor.

The Engineer shall, in all cases, determine the portion of the site to be used by the Contractor for storage, plant or for other purposes. If, however, it becomes necessary to remove and restack materials to avoid impeding the progress of any part of the work or interference with the work to be done by any other Contractor, the Contractor shall remove and restack such materials at his own expense.

G-4.08 TOOLS AND ACCESSORIES

The Contractor shall, unless otherwise stated in the Contract Documents, furnish with each type, kind or size of equipment, one complete set of suitably marked high grade special tools and appliances which may be needed to adjust, operate, maintain, or repair the equipment. Such tools and appliances shall be furnished in approved painted steel cases, properly labeled and equipped with good grade cylinder locks and duplicate keys.

Spare parts shall be furnished as specified.

Each piece of equipment shall be provided with a substantial nameplate, securely fastened in place and clearly inscribed with the manufacturer's name, year of manufacture, serial number, weight and principal rating data.

G-4.09 INSTALLATION OF EQUIPMENT

The Contractor shall have on hand sufficient proper equipment and machinery of ample capacity to facilitate the work and to handle all emergencies normally encountered in work of this character.

Equipment shall be erected in a neat and workmanlike manner on the foundations at the locations and elevations shown on the Plans, unless directed otherwise by the Engineer during installation. All equipment shall be correctly aligned, leveled and adjusted for satisfactory operation and shall be installed so that proper and necessary connections can be made readily between the various units.

The Contractor shall furnish, install and protect all necessary anchor and attachment bolts and all other appurtenances needed for the installation of the devices included in the equipment specified. Anchor bolts shall be as approved by the Engineer and made of ample size and strength for the purpose intended. Substantial templates and working drawings for installation shall be furnished.

The Contractor shall, at his own expense, furnish all materials and labor for, and shall properly bed in non-shrink grout, each piece of equipment on its supporting base that rests on masonry foundations. Grout shall completely fill the space between the equipment base and the foundation.

G-4.10 OPERATING INSTRUCTIONS

The Contractor, through qualified individuals, shall adequately instruct designated employees of the City in the operation and care of all equipment installed hereunder, except for equipment that may be furnished by the City.

The Contractor shall also furnish and deliver to the Engineer three complete sets for permanent files, identified in accordance with Subsection G-3.01 hereof, of instructions, technical bulletins and any other printed matter, such as diagrams, prints or drawings, containing full information required for the proper operation, maintenance, and repair, of the equipment installed and the ordering of spare parts, except for equipment that may be furnished by the City.

In addition to the above three copies, the Contractor shall furnish any additional copies that may be required for use during construction and start-up operations.

G-4.11 SERVICE OF MANUFACTURER'S ENGINEER

The Contract prices for equipment shall include the cost of furnishing a competent and experienced engineer or superintendent who shall represent the manufacturer and shall assist the Contractor, when required, to install, adjust, test and place in operation the equipment in conformity with the Contract Documents. After the equipment is placed in

permanent operation by the City, such engineer or superintendent shall make all adjustments and tests required by the Engineer to provide that such equipment is in proper and satisfactory operating condition, and shall instruct such personnel as may be designated by the City in the proper operation and maintenance of such equipment.

SECTION 5 INSPECTION AND TESTING

G-5.01 GENERAL

The Contractor's attention is hereby directed to Article 3.03 of the Agreement.

Inspection and testing of materials will be performed by the City unless otherwise specified.

For tests specified to be made by the Contractor, the testing personnel shall make the necessary inspections and tests and the reports thereof shall be in such form as will facilitate checking to determine compliance with the Contract Documents. Five copies of the reports shall be submitted and authoritative certification thereof must be furnished to the Engineer as a prerequisite for the acceptance of any material or equipment.

If, in the making of any test of any material or equipment, it is ascertained by the Engineer that the material or equipment does not comply with the Contract, the Contractor will be notified thereof and he will be directed to refrain from delivering said material and equipment, or to remove it promptly from the site or from the work and replace it with acceptable material, without cost to the City.

Tests of electrical and mechanical equipment and appliances shall be conducted in accordance with recognized test codes of the ANSI, ASME, or the IEEE, except as may otherwise be stated herein.

The Contractor shall be fully responsible for the proper operation of equipment during tests and instruction periods and shall neither have nor make any claim for damage which may occur to equipment prior to the time when the City formally takes over the operation thereof.

G-5.02 COSTS

All inspection and testing of materials furnished under this Contract will be performed by the City or duly authorized inspection engineers or inspection bureaus without cost to the Contractor, unless otherwise expressly specified.

The cost of shop and field tests of equipment and of certain other tests specifically called for in the Contract Documents shall be borne by the Contractor and such costs shall be deemed to be included in the contract price.

Materials and equipment submitted by the Contractor as the equivalent to those specifically named in the Contract may be tested by the City for compliance. The Contractor shall reimburse the City for the expenditures incurred in making

such tests on materials and equipment which are rejected for noncompliance.

G-5.03 INSPECTIONS OF MATERIALS

The Contractor shall give notice, in writing to the Engineer, sufficiently in advance of his intention to commence the manufacture or preparation of materials especially manufactured or prepared for use in or as part of the permanent construction. Such notice shall contain a request for inspection, the date of commencement and the expected date of completion of the manufacture or preparation of materials. Upon receipt of such notice the Engineer will arrange to have a representative present at such times during the manufacture as may be necessary to inspect the materials or he will notify the Contractor that inspection will be made at a point other than the point of manufacture, or he will notify the Contractor that inspection will be waived. The Contractor must comply with these provisions before shipping any material. Such inspection shall not release the Contractor from the responsibility for furnishing materials meeting the requirements of the Contract Documents.

G-5.04 CERTIFICATE OF MANUFACTURE

When inspection is waived or when the Engineer so requires, the Contractor shall furnish to him authoritative evidence in the form of Certificates of Manufacture that the materials to be used in the work have been manufactured and tested in conformity with the Contract Documents. These certificates shall be notarized and shall include copies of the results of physical tests and chemical analyses, where necessary, that have been made directly on the product or on similar products of the manufacturer.

G-5.05 SHOP TESTS OF OPERATING EQUIPMENT

Each piece of equipment for which pressure, duty, capacity, rating, efficiency, performance, function, or special requirements are specified shall be tested in the shop of the maker in a manner which shall conclusively prove that its characteristics comply fully with the requirements of the Contract Documents. No such equipment shall be shipped to the work until the Engineer notifies the Contractor, in writing, that the results of such tests are acceptable.

Five copies of the manufacturer's actual test data and interpreted results thereof, accompanied by a certificate of authenticity sworn to by a responsible official of the manufacturing company, shall be forwarded to the Engineer for approval.

The cost of the shop tests and of furnishing manufacturer's preliminary and shop test data of operating equipment shall be borne by the Contractor.

G-5.06 PRELIMINARY FIELD TESTS

As soon as conditions permit, the Contractor shall furnish all labor, materials, and instruments and shall make preliminary field tests of equipment. If the preliminary field tests disclose any equipment furnished under this Contract which does not comply with the requirements of the Contract Documents, the Contractor shall, prior to the acceptance tests, make all changes, adjustments, and replacements required.

TEMPORARY STRUCTURES

G-5.07 FINAL FIELD TESTS

Upon completion of the work and prior to final payment, all equipment and appliances installed under this Contract shall be subjected to acceptance tests as specified or required to prove compliance with the Contract Documents.

The Contractor shall furnish labor, fuel, energy, water and all other materials, equipment, and instruments necessary for all acceptance tests, at no additional cost to the City.

G-5.08 FAILURE OF TESTS

Any defects in the materials and equipment or their failure to meet the tests, guarantees or requirements of the Contract Documents shall be promptly corrected by the Contractor by replacements or otherwise. The decision of the Engineer as to whether or not the Contractor has fulfilled his obligations under the Contract shall be final and conclusive. If the Contractor fails to make those corrections or if the improved materials and equipment, when tested, shall again fail to meet the guarantees or specified requirements, the City, notwithstanding its partial payment for work, and materials and equipment, may reject the materials and equipment and may order the Contractor to remove them from the site at his own expense.

In case the City rejects any materials and equipment, then the Contractor shall replace the rejected materials and equipment within a reasonable time. If he fails to do so, the City may, after the expiration of a period of thirty calendar days after giving him notice in writing, proceed to replace such rejected materials and equipment, and the cost thereof shall be deducted from any compensation due or which may become due the Contractor under this Contract.

The City agrees to obtain other equipment within a reasonable time and the Contractor agrees that the City may use the equipment furnished by him without rental or other charges until the new equipment is obtained.

Materials or work in place that fails to pass acceptability tests shall be retested at the direction of the construction engineer all such retests shall be at the Contractor's expense. The rates charged shall be in accordance with the Department of Public Works current annual inspection contract which is available for inspection at the offices of the Department of Public Works.

G-5.09 FINAL INSPECTION

The procedures for final inspection shall be in accordance with the provisions of Article 4.07 of the Agreement. During such final inspections, the work shall be clean and free from water. In no case will the final estimate be prepared until the Contractor has complied with all the requirements set forth and the Engineer has made his final inspection of the entire work and is satisfied that the entire work is properly and satisfactorily constructed in accordance with the requirements of the Contract Documents.

SECTION 6

G-6.01 GENERAL

All false work, scaffolding, ladders, hoistways, braces, pumping plants, shields, trestles, roadways, sheeting, centering forms, barricades, drains, flumes, and the like, any of which may be needed in the construction of any part of the work and which are not herein described or specified in detail, must be furnished, maintained and removed by the Contractor, and he shall be responsible for the safety and efficiency of such works and for any damages that may result from their failure or from their improper construction, maintenance, or operation.

G-6.02 PUBLIC ACCESS

At all points in the work where public access to any building, house, place of business, public road, or sidewalk would be obstructed by any action of the Contractor in executing the work required by this Contract, the Contractor shall provide such temporary structure, bridges or roadway as may be necessary to maintain public access at all times. At least one lane for vehicular traffic shall be maintained in streets in which the Contractor is working. Street closure permits are required from the Department of Public Works.

The Contractor shall provide suitable temporary bridges, as directed by the Engineer, at street intersections when necessary for the maintenance of vehicular and pedestrian traffic.

Prior to temporarily cutting of access to driveways and garages, the Contractor shall give twelve (12) hours notice to affected property owners. Interruptions to use of private driveways shall be kept to a minimum.

G-6.03 CONTRACTOR'S FIELD OFFICE

The Contractor shall erect, furnish and maintain a field office with a telephone at the site during the entire period of construction. He or an authorized agent shall be present at this office at all times while his work is in progress. Readily accessible copies of both the Contract Documents and the latest approved working drawings shall be kept at this field office.

G-6.04 TEMPORARY FENCE

If, during the course of the work, it is necessary to remove or disturb any fence or part thereof, the Contractor shall, at his own expense, if so ordered by the Engineer, provide a suitable temporary fence which shall be maintained until the permanent fence is replaced. The Engineer shall be solely responsible for the determination of the necessity for providing a temporary fence and the type of temporary fence to be used.

G-6.05 RESPONSIBILITY FOR TEMPORARY STRUCTURES

In accepting the Contract, the Contractor assumes full responsibility for the sufficiency and safety of all temporary structures or work and for any damage which may result from their failure or their improper construction, maintenance, or operation and will indemnify and save harmless the City from

all claims, suits or actions and damages or costs of every description arising by reason of failure to comply with the above provisions.

SECTION 7 TEMPORARY SERVICES

G-7.01 WATER

The Contractor shall provide the necessary water supply at his own expense. He shall, if necessary, provide and lay necessary waterlines from existing mains to the place of using, shall secure all necessary permits and pay for all taps to water mains or hydrants and for all water used at the established rates.

G-7.02 LIGHT AND POWER

The Contractor shall provide, at his own expense, temporary lighting and power facilities required for the proper prosecution and inspection of the work. If, in the opinion of the Engineer, these facilities are inadequate, the Contractor will not be permitted to proceed with any portion of the work affected thereby.

G-7.03 SANITARY REGULATIONS

The Contractor shall prohibit and prevent the committing of nuisances on the site of the work or on adjoining property and shall discharge any employee who violates this rule.

Ample washrooms and toilet facilities and a drinking water supply shall be furnished and maintained in strict conformity with the law by the Contractor for use by his employees.

G-7.04 ACCIDENT PREVENTION

Precautions shall be exercised at all times for the protection of persons and property. The safety provisions of applicable laws, building and construction codes shall be observed. The Contractor shall comply with the U. S. Department of Labor Safety and Health Regulations for construction promulgated under the Occupational Safety and Health Act of 1970 (PL 91-596), and under Section 107 of the Contract Work. Hours and Safety Standards Act (PL 91-54), except where state and local safety standards exceed the federal requirements and except where state safety standards have been approved by the Secretary of Labor in accordance with provisions of the Occupational Safety and Health Act.

G-7.05 FIRST AID

The Contractor shall keep upon the site, at each location where work is in progress, a completely equipped first aid kit and shall provide ready access thereto at all times when men are employed on the work.

G-7.06 HEATING

The Contractor shall provide temporary heat, at his own expense, whenever required on account of work being carried on during cold weather and to prevent freezing of water pipes and other damage to the work.

SECTION 8

LINES AND GRADES

G-8.01 GENERAL

All work done under this Contract shall be constructed in accordance with the lines and grades shown on the Plans, or as given by the Engineer. The full responsibility for keeping alignment and grade shall rest upon the Contractor.

The Engineer will establish bench marks and base line controlling points. Reference remarks for lines and grades as the work progresses will be located to cause as little inconvenience to the prosecution of the work as possible. The Contractor shall so place excavation and other materials as to cause no inconvenience in the use of the use of the reference marks provided. He shall remove any obstructions placed by him contrary to this provision.

G-8.02 SURVEYS

The Contractor shall furnish and maintain, at his own expense, stakes and other such materials, and give such assistance, including qualified helpers, as may be required by the Engineer for setting reference marks. The Contractor shall check such reference marks by such means as he may deem necessary and, before using them, shall call the Engineer's attention to any inaccuracies. The Contractor shall, at his own expense, establish all working or construction lines and grades as required from the reference marks set by the Engineer, and shall be solely responsible for the accuracy thereof. He shall, however, be subject to the check and review of the Engineer.

The Contractor shall keep the Engineer informed a reasonable time in advance as to his need for line and grade reference marks, in order that they may be furnished and all necessary measurements made for record and payment with the minimum of inconvenience to the Engineer or of delay to the Contractor.

It is the intention not to delay the work for the establishment of reference marks but, when necessary, working operations shall be suspended for such reasonable time as the Engineer may require for this purpose.

G-8.03 SAFEGUARDING MARKS

The Contractor shall safeguard all points, stakes, grade marks, monuments and bench marks made or established on the work, bear the cost of reestablishing them if disturbed, and bear the entire expense of rectifying work improperly installed due to not maintaining or protecting or to removing without authorization such established points, stakes and marks.

The Contractor shall safeguard all existing and known property corners, monuments and marks adjacent to but not related to the work and, if required, shall bear the cost of reestablishing them if disturbed or destroyed.

G-8.04 DATUM PLANE

All elevations indicated or specified refer to the Mean Sea Level Datum of the U.S.C. & G.S. (N.O.S.) which is 0.80 feet above the Mean Low Water Datum of the U. S. Army

Corps of Engineers.

SECTION 9 ADJACENT STRUCTURES AND LANDSCAPING

G-9.01 RESPONSIBILITY

The responsibility for removal, replacement, relocation, repair, rebuilding or protection of all public utility installations, including poles, tracks, pipes, wires, conduits, house service connections, vaults, manholes, sewers, traffic control and fire alarm signal circuit installations and other appurtenances and facilities shall be in accordance with G-1.02 and G-1.03.

The Contractor shall also be entirely responsible and liable for all damage or injury as a result of his operations to all other adjacent public and private property, structures of any kind and appurtenances thereto met with during the progress of the work. The cost of protection, replacement in their original locations and conditions or payment of damages for injuries to such adjacent public and private property and structures affected by the work, whether or not shown on the Plans, and the removal, relocation, and reconstruction of such items called for on the Plans or specified shall be included in the various Contract Items and no separate payment will be made therefor. Where such public and private property, structures of any kind and appurtenances thereto are not shown on the Plans and when, in the opinion of the Engineer, removal or relocation and reconstruction is necessary to avoid interference with the work, payment therefor will be made as provided for extra work in Article 7.02 of the Agreement.

G-9.02 PROTECTION OF TREES

All trees and shrubs shall be adequately protected by the Contractor with boxes or otherwise and, within the City of Tampa, in accordance with ordinances governing the protection of trees. No excavated materials shall be placed so as to injure such trees or shrubs. Trees or shrubs destroyed by negligence of the Contractor or his employees shall be replaced by him with new stock of similar size and age, at the proper season, and at the sole expense of the Contractor.

Beneath trees or other surface structures, where possible, pipelines may be built in short tunnels, backfilled with excavated materials, except as otherwise specified, or the trees or structures carefully supported and protected from damage.

The City may order the Contractor, for the convenience of the City, to remove trees along the line of trench excavation. If so ordered, the City will obtain any permits required for removal of trees. Such tree removal ordered shall be paid for under the appropriate Contract Items.

G-9.03 LAWN AREAS

Lawn areas shall be left in as good condition as before the starting of the work. Where sod is to be removed, it shall be carefully removed and later replaced, or the area where sod has been removed shall be restored with new sod in the

manner described in the Technical Specifications section.

G-9.04 RESTORATION OF FENCES

Any fence, or part thereof, that is damaged or removed during the course of the work shall be replaced or repaired by the Contractor and shall be left in as good a condition as before the starting of the work. The manner in which the fence is repaired or replaced and the materials used in such work shall be subject to the approval of the Engineer. The cost of all labor, materials, equipment, and work for the replacement or repair of any fence shall be deemed included in the appropriate Contract Item or Items, or if no specific Item is provided therefor, as part of the overhead cost of the work, and no additional payment will be made therefor.

SECTION 10 PROTECTION OF WORK AND PUBLIC

G-10.01 TRAFFIC REGULATIONS

The Contractor shall arrange his work to comply with Article G-6.02. The work shall be done with the least possible inconvenience to the public and to that end the work may be confined by the Engineer to one block at a time.

G-10.02 BARRIERS AND LIGHTS

During the prosecution of the work, the Contractor shall put up and maintain at all times such barriers, and lights, as will effectually prevent accidents. The Contractor shall provide suitable barricades, red lights, "danger" or "caution" or "street closed" signs and watchmen at all places where the work causes obstructions to the normal traffic or constitutes in any way a hazard to the public. Such barriers and signs shall be constructed to State of Florida Department of Transportation standards and placed as recommended by the Traffic Division of the City's Department of Public Works.

No open fires will be permitted.

G-10.03 SMOKE PREVENTIONS

The Contractor shall use hard coal, coke, oil or gas as fuel for equipment generating steam. A strict compliance with ordinances regulating the production and emission of smoke will be required.

G-10.04 NOISE

The Contractor shall eliminate noise to as great an extent as practicable at all times. Air compressing plants shall be equipped with silencers and the exhaust of all gasoline motors or other power equipment shall be provided with mufflers. In the vicinity of hospitals and schools, special care shall be used to avoid noise or other nuisances. The Contractor shall strictly observe all local regulations and ordinances covering noise control.

Except in the event of an emergency, no work shall be done between the hours of 7:00 p.m. and 7:00 a.m., or on Sundays.

If the proper and efficient prosecution of the work requires operations during the night, the written permission of the Engineer shall be obtained before starting such items of the work.

**SECTION 13
CLEANING**

G-10.05 ACCESS TO PUBLIC SERVICES

Neither the materials excavated nor the materials or plant used in the construction of the work shall be so placed as to prevent free access to all fire hydrants, valves or manholes.

G-10.06 DUST PREVENTION

The Contractor shall prevent dust nuisance from his operations or from traffic by keeping the streets sprinkled with water at all times.

G-10.07 PRIVATE PROPERTY

The Contractor shall so conduct the work that no equipment, material, or debris will be placed or allowed to fall upon private property in the vicinity of the work unless he shall have obtained the owner's written consent thereto and shall have shown this consent to the Engineer.

**SECTION 11
SLEEVES AND INSERTS**

G-11.01 COORDINATION

When the Contract requires the placing of conduits, saddles, boxes, cabinets, sleeves, inserts, foundation bolts, anchors, and other like work in floors, roofs, or walls of buildings and structures, they shall be promptly installed in conformity with the construction program. The Contractor who erects the floors, roofs, and walls shall facilitate such work by fully cooperating with the Contractors responsible for installing such appurtenances. The Contractor responsible for installing such appurtenances shall arrange the work in strict conformity with the construction schedule and avoid interference with the work of other contractors.

G-11.02 OPENINGS TO BE PROVIDED

In the event timely delivery of sleeves and other materials cannot be made and to avoid delay, the affected Contractor may arrange to have boxes or other forms set at the locations where the appurtenances are to pass through or into the floors, roofs, walls, or other work. Upon the subsequent installation of these appurtenances, the Contractor erecting the structure shall fill around them with materials as required by the Contract. The necessary expenditures incurred for the boxing out and filling in shall be borne by the Contractor or Contractors required to furnish the sleeves and inserts. Formed openings and later installation of sleeves will not be permitted at locations subject to hydrostatic pressure.

**SECTION 12
CUTTING AND PATCHING**

G-12.01 GENERAL

The Contractor shall do all cutting, fitting, or patching of his portion of the work that may be required to make the several parts thereof join and coordinate in a manner satisfactory to the Engineer and in accordance with the Plans and Specifications. The work must be done by competent workmen skilled in the trade required by the restoration.

G-13.01 DURING CONSTRUCTION

During construction of the work, the Contractor shall, at all times, keep the site of the work and adjacent premises as free from material, debris, and rubbish as is practicable and shall remove the same from any portion of the site if, in the opinion of the Engineer, such material, debris, or rubbish constitutes a nuisance or is objectionable.

The Contractor shall remove from the site all of his surplus materials and temporary structures when no further need therefor develops.

G-13.02 FINAL CLEANING

At the conclusion of the work, all erection plant, tools, temporary structures and materials belonging to the Contractor shall be promptly taken away, and he shall remove and promptly dispose of all water, dirt, rubbish or any other foreign substances.

The Contractor shall thoroughly clean all equipment and materials installed by him and shall deliver such materials and equipment undamaged in a bright, clean, polished, and new appearing condition.

**SECTION 14
MISCELLANEOUS**

G-14.01 PROTECTION AGAINST SILTATION AND BANK EROSION

The Contractor shall arrange his operations to minimize siltation and bank erosion on construction sites and on existing or proposed watercourses and drainage ditches.

G-14.02 EXISTING FACILITIES

The work shall be so conducted to maintain existing facilities in operation insofar as is possible. Work shall be scheduled to minimize bypassing during construction. Requirements and schedules of operations for maintaining existing facilities in service during construction shall be as described in the Special Provisions.

G-14.03 USE OF CHEMICALS

All chemicals used during project construction or furnished for project operation, whether herbicide, pesticide, disinfectant, polymer, reactant or of other classification, must show approval of either EPA or USDA. Use of all such chemicals and disposal of residues shall be in strict conformance with instructions.



Page 1 of 2 –DMI Payment
City of Tampa – DMI Sub-(Contractors/Consultants/Suppliers) Payments
(FORM MBD-30)

[] Partial [] Final

Contract No.: _____ WO#,(if any): _____ Contract Name: _____

Contractor Name: _____ Address: _____

Federal ID: _____ Phone: _____ Fax: _____ Email: _____

GC Pay Period: _____ Payment Request/Invoice Number: _____ City Department: _____

Total Amount Requested for pay period: \$ _____ Total Contract Amount(including change orders):\$ _____

Type of Ownership - (F=Female M=Male), BF BM = African Am., HF HM = Hispanic Am., AF AM = Asian Am., NF NM → Native Am., CF CM = Caucasian S = SLBE

Type	Company Name Address Phone & Fax	Total Sub Contract Or PO Amount	Amount Paid To Date	Amount To Be Paid For This Period
Trade/Work Activity			Amount Pending Previously Reported	Sub Pay Period Ending Date
[]Sub []Supplier				
Federal ID				
			\$	\$
			\$	\$
			\$	\$
			\$	\$
			\$	\$
			\$	\$

(Modifying This Form or Failure to Complete and Sign May Result in Non-Compliance)

Certification: I hereby certify that the above information is a true and accurate account of payments to sub – contractors/consultants on this contract.

Signed: _____ Name/Title: _____ Date: _____



Page 2 of 2 – DMI Payment
Instructions for completing The DMI Sub-(Contractors/Consultants/ Suppliers) Payment Form
(Form MBD-30)

This form must be submitted with all invoicing or payment requests where there has been subcontracting rendered for the pay period. If applicable, after payment has been made to the subcontractor, “Waiver and Release of Lien upon Progress Payment”, “Affidavit of Contractor in Connection with Final Payment”, or an affidavit of payment must be submitted with the amount paid for the pay period. The following will detail what data is required for this form. The instructions that follow correspond to the headings on the form required to be completed. **(Modifying or omitted information from this form my result in non-compliance).**

- **Contract No.** This is the number assigned by the City of Tampa for the bid or proposal.
- **W.O.#** If the report covers a work order number (W.O.#) for the contract, please indicate it in that space.
- **Contract Name.** This is the name of the contract assigned by the City of Tampa for the bid or proposal.
- **Contractor Name.** The name of your business.
- **Address.** The physical address of your business.
- **Federal ID.** A number assigned to a business for tax reporting purposes.
- **Phone.** Telephone number to contact business.
- **Fax.** Fax number for business.
- **Email.** Provide email address for electronic correspondence.
- **Pay Period.** Provide start and finish dates for pay period. (e.g. 05/01/13 – 05/31/13)
- **Payment Request/Invoice Number.** Provide sequence number for payment requests. (ex. Payment one, write 1 in space, payment three, write 3 in space provided.)
- **City Department.** The City of Tampa department to which the contract pertains.
- **Total Amount Requested for pay period.** Provide all dollars you are expecting to receive for the pay period.
- **Total Contract Amount (including change orders).** Provide expected total contract amount. This includes any change orders that may increase or decrease the original contract amount.
- **Signed/Name/Title/Date.** This is your certification that the information provided on the form is accurate.
- **See attached documents.** Check if you have provided any additional documentation relating to the payment data. Located at the bottom middle of the form.
- **Partial Payment.** Check if the payment period is a partial payment, not a final payment. Located at the top right of the form.
- **Final Payment.** Check if this period is the final payment period. Located at the top right of the form.

The following instructions are for information of any and all subcontractors used for the pay period.

- **(Type) of Ownership.** Indicate the Ethnicity and Gender of the owner of the subcontracting business or SLBE.
- **Trade/Work Activity.** Indicate the trade, service, or material provided by the subcontractor.
- **SubContractor/SubConsultant/Supplier.** Please indicate status of firm on this contract.
- **Federal ID.** A number assigned to a business for tax reporting purposes. This information is critical in proper identification of the subcontractor.
- **Company Name, Address, Phone & Fax.** Provide company information for verification of payments.
- **Total Subcontract Amount.** Provide total amount of subcontract for subcontractor including change orders.
- **Amount Paid To Date.** Indicate all dollars paid to date for the subcontractor.
- **Amount Pending, Previously Reported.** Indicate any amount previously reported that payments are pending.
- **Amount To Be Paid for this Period.** Provide dollar amount of dollars requested for the pay period.
- **Sub Pay Period Ending Date.** Provide date for which subcontractor invoiced performed work.

Forms must be signed and dated or will be considered incomplete. The company authorized representative must sign and certify the information is true and accurate. Failure to sign this document or return the document unsigned can be cause for determining a company is in non-compliance of Ordinance 2008-89.

If any additional information is required or you have any questions, you may call the Minority Business Development Office at (813) 274-5522.

0 1 2 3 4 5 6 7 8

Sign Information

Building a Better Tampa

Downtown Riverwalk

Creates a waterfront pedestrian walkway connecting the south edge of the CapTrust building with MacDill Park.

**\$1.5 Million investment
Scheduled for completion in October, 2012**

**Orion Marine
Construction, Inc.**

Improvement Project



Mayor Bob Buckhorn

Project Contact:
Don Cermeno
Contract Administration
City of Tampa
Don.Cermeno@tampagov.net



For information call:
(813) 635-3400

Building a Better Tampa

**David L. Tippin Water Treatment Facility
Caustic Soda Piping Improvements**

Project provides for improvements at the David L. Tippin Water Treatment Facility to improve the reliability and safety of the Sodium Hydroxide System of the water distribution system within the facility.

**\$7BD investment
Scheduled for completion in TBD 2014**

TBD

Colors

Blue: Sherwin Williams Naval SW6244
Green: Sherwin Williams Center Stage SW6920
White: Sherwin Williams Pure White SW7005

SIGN EXAMPLE ONLY GRAPHIC TO BE DEVELOPED BY CONTRACTOR

3"

scale: 3"

Font

Franklin Gothic

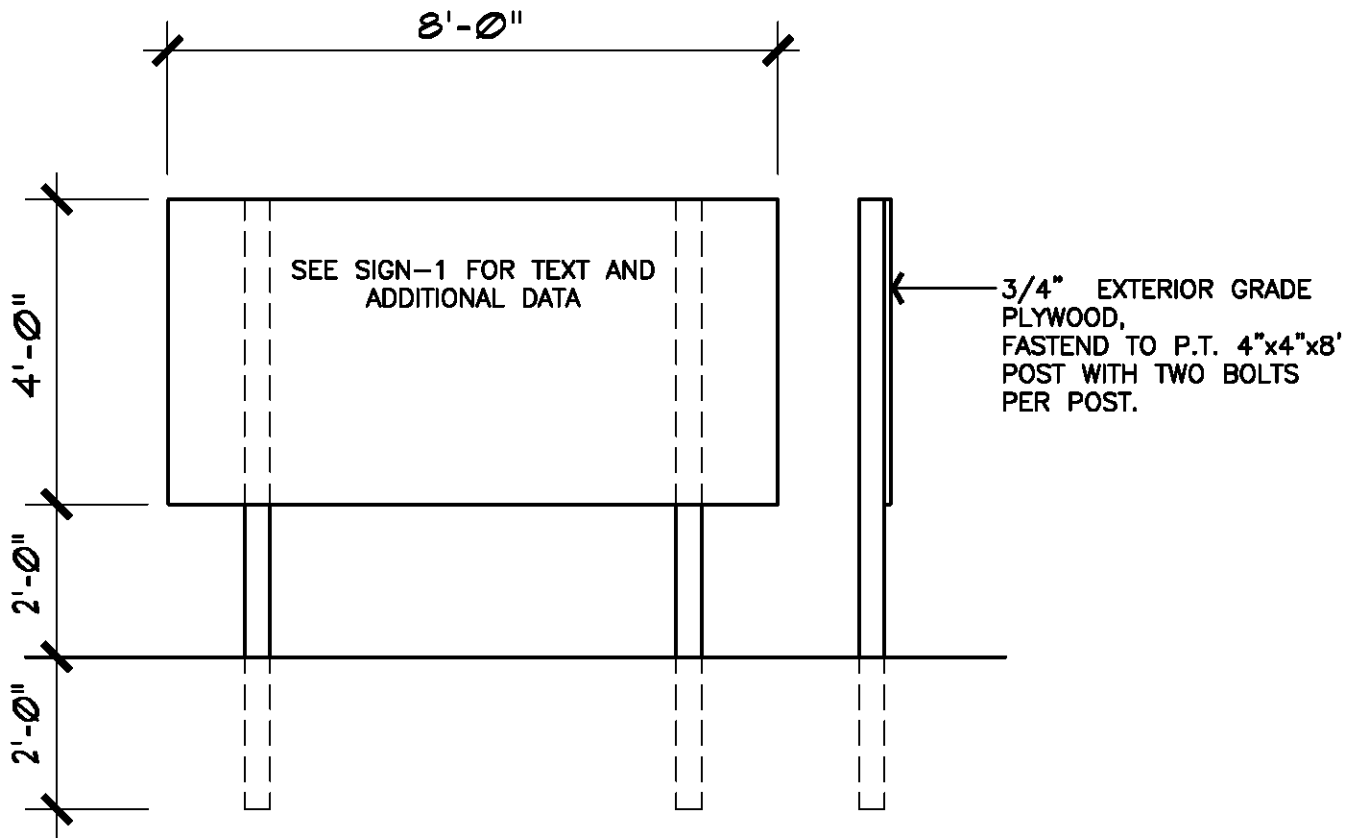

SPECIFIC PROVISIONS

S-1.01 GENERAL

The Specific Provisions are intended as modifications or supplements to Instructions to Bidders, General Provisions and the Tampa Agreement. All costs associated with the requirements set forth in the specific provisions shall be incidental to the items of work. No additional compensation will be provided. To the extent such provisions are not modified or supplemented herein, all provisions remain in full force and effect.

The work will be located in various locations in the City's water service area and will be given out on a work order by work order basis. A separate set of plans or work directives will be provided for each work order.

The City of Tampa reserves the right to require the Contractor to change his "Contractor Superintendent" at any time.

S-2.01 DEFINITIONS

Add or amend the Definitions in Article 1.02 of the Agreement to these documents as follows:

"Department"

Add the following: "Whenever the word "Department" is used in the Contract Documents, it shall mean the "City of Tampa Water Department".

"Red-line Drawing" refers to drawing maintained by the Contractor depicting changes (as constructed) from original plans.

"Work Order Work" is defined as all work required to be performed pursuant to the terms of this contract and a Work Order issued in accordance with these Contract Documents.

S-3.01 APPLICABLE CODES OR STANDARDS

When words that have a well-known technical or trade meaning are used to describe work, materials or equipment, such words shall be interpreted in accordance with such meaning.

When reference is made to codes or standards of organizations as outlined in Section G-4.03 of the General Provisions, it shall mean the latest revision thereof. However, no provision of any reference standard specification, manual or code (whether or not specifically incorporated by reference in the Contract Documents) shall change the duties and responsibilities of the City, Engineer or Contractor, or any of their agents or employees from those set forth in the Contract Documents.

S-4.01 DESCRIPTION OF WORK & WORK ORDERS

It is anticipated that the work to be performed under this Contract may include, but is not limited to, the following three (3) categories: Meter service installations, scheduled construction services, and non-scheduled construction services.

A. Meter Services. Install new potable and reclaimed water meter services in accordance with TWD Standard Meter Construction Details, to include tapping a water main, installing a City-provided meter, and performing required restoration.

The Department expects 1,000 new meter service installations will be required annually - typically half each of long-side services (when the source water main is more than 15 ft. from the proposed meter location) and short-side services (source water main is 15 ft. or less from the proposed meter location). Meter installation work orders issued to a Contractor will depend on performance and timeliness of completion on previous meter installation work orders issued to that Contractor, to include satisfactory restoration.

B. Scheduled (and, C. Non-scheduled (Emergency)) Work Orders shall include:

- i. repair and/or replacement of broken water mains;
- ii. removal and/or replacement or installation of isolated distribution or transmission water main valves;
- iii. potable or reclaimed water main relocations due to conflicts with construction proposed by others within the public rights-of-way;
- iv. restoration within the public rights-of-way for isolated water main repair jobs performed by others, or as directed by the Engineer;
- v. removal and/or replacement or installation of fire hydrant assemblies;
- vi. removal of below grade large DDCVA/Meter Vaults and/or installation of DDCVA/Large Meter Assemblies above- or below-grade per Water Department Standard Construction Details;
- vii. other miscellaneous water construction/repair projects required to maintain the water distribution and transmission systems.

The Contractor shall furnish all labor, materials and equipment for the accomplishment of all work as described in the Specifications, as shown on Plans if provided, and as directed by the Engineer in accordance with the expressed or obvious intent of the Contract. Work will be located throughout the City of Tampa and in adjacent portions of Hillsborough County where the City's water service area extends beyond City limits.

The City reserves the right to assign quantities of work to the contractor based on performance criteria, including but not necessarily limited to, the ability to meet acceptable schedules, the ability to

City-wide Meter, Hydrant and Valve Installation and Replacement
Contract 18-C-00030

satisfactorily complete leakage/pressure tests and other construction testing, and timeliness of satisfactory restoration.

Primary City concerns when awarding this contract are Contractor capability and commitment to performing and maintaining the service levels defined in Specific Provisions section S-4.02 Provisions For Time Sensitive Work Orders. City expectation is Contractor compliance with the specified service levels at least 98% of the time - for the six types of work orders listed therein.

Work Orders will typically originate from the Department's Distribution Division and will generally be isolated construction projects not associated with significant pipeline construction projects - such as individual meter service installations, single fire hydrant installations/removals/replacements, restoration jobs, valve installations and/or replacements, water distribution/transmission system components maintenance repairs or replacements, etc. As noted above, certain Work Orders will require expedited construction. Work Orders issued for construction other than the six expedited types described will not require expedited scheduling - completion time will instead be as agreed by the Contractor and City Engineer when the work order is issued.

Emergency Work Orders issued through the Contract will be in response to water main breaks, emergency valve replacements, or other water facilities emergency work required of the Department by others, as directed by the Engineer. Compensation for Emergency Work shall be provided based on Contractor time (labor), equipment, and materials expended to accomplish the emergency construction required, as verified by the Engineer. Payment for labor shall be based on actual hours expended for emergency construction, as reported in monthly certified payroll reports (including Contractor burden) provided to the City by the Contractor, and will include a 15% OH&P mark-up. Materials used for emergency construction will be compensated via invoices provided by the Contractor, and will include a 15% OH&P mark-up. Compensation for equipment utilized for emergency construction shall be via applicable FHWA Rates taken from the current Rental Rate Blue Book for Construction - because the FHWA Rate includes mark-up, no additional mark-up will be allowed for equipment used.

Because Emergency Work Orders will generally require immediate response from the Contractor, initial notification for such work will be via telephone contact from an authorized Department representative. Following telephone notification, and as soon as is practicable, a confirming e-mail will be sent from the Department to the Contractor documenting the directed Emergency Work.

In the event of an emergency or urgent work, as identified by the Engineer or his designee, the Contractor will be required to respond to the request of the Engineer or his designated representative, and mobilize as required or agreed.

Work Orders for non-Emergency construction services shall be issued to the Contractor in writing for each project requested by the City. All such notices shall indicate the date of issuance and include a cost estimate for the work required. Within seven (7) calendar days of receiving a Work Order (for non-

City-wide Meter, Hydrant and Valve Installation and Replacement
Contract 18-C-00030

expedited and non-Emergency construction) the Contractor shall provide the City a schedule for completing that work. Work Orders issued requiring expedited construction (i.e., requiring completion within 1-day to 2-weeks of release to the Contractor) will not require schedule submittals.

The Contractor's work schedule (when provided for non-expedited work orders) shall contain the detail and duration of all required work tasks, including delivery of as-built drawings. The City shall review the work schedule and return it for correction, or review the work schedule and acknowledge its receipt.

Though the City will generate its own cost estimate for non-Emergency Work Orders, the Contractor shall review the plans and produce a cost estimate for all non-expedited Work Orders. If items are listed or shown for construction in the plans that are not in the Contract, or a price has not previously been agreed for those items, the Contractor shall propose costs to furnish and install the non-contract items.

Once the City acknowledges receipt of a schedule and cost estimate, it will become the official schedule for that work order and the City will issue the Notice to Proceed (a work order authorization) for that project. Upon receipt of a Notice to Proceed (work order authorization) from the City, the Contractor shall mobilize to the site and begin work within twenty (20) calendar days. For any work order with a total estimated value equal to or less than \$50,000 and for which the contractor does not mobilize to the site and begin work within twenty (20) calendar days of the start date delineated in the work order authorization (unless otherwise directed by the Engineer), the Department will assess liquidated damages of \$500.00 per day for each calendar day that their actual mobilization and start work date exceeds the aforementioned twenty (20) calendar day window.

Non-expedited Work Orders shall be constructed within the time frame outlined in the official work schedule for that work order. In the event that the City determines that work on a particular work order is not progressing in a satisfactory manner and at a reasonable speed, it may, at its discretion, authorize the completion of the work by others. The Contractor will only be compensated for the work completed and the City is not obligated to the Contractor for uncompleted work remaining on the work order or contract

S-4.02 PROVISIONS FOR TIME SENSITIVE WORK ORDER WORK

When issued to the Contractor for construction, new meter installation, restoration, and fire hydrant (relocation, replacement, or isolated new installation) work orders will have expedited level of service (L.O.S.) requirements - for each, construction must be completed within a specified time period. Maximum completion times allowed for each are as follows:

New Meter Installations	2 weeks
Restoration - State roads	1 day
Restoration - Streets, non-State roads	7 days
Restoration - Driveways	8 days

City-wide Meter, Hydrant and Valve Installation and Replacement
Contract 18-C-00030

Restoration - Sidewalks	10 days
Fire Hydrants	10 days

The Contractor is expected to meet service levels specified for these types of work orders at least 98% of the time.

S-4.03 EXTRA WORK

Compensation for Extra Work (i.e., construction work required to complete an issued work order but that is not included or addressed within the Contract) shall be in accordance with Tampa Agreement Article 7.02 EXTRA WORK. If City and Contractor cannot agree on acceptable unit rates or lump sum price for required Extra Work and compensation must instead be provided per sub-paragraph (c) in Article 7.02, labor rates shall be taken from the Contractor's certified payroll, and equipment rates shall be taken from the current Rental Rate Blue Book for Construction Equipment.

S-4.04 AVAILABLE RESOURCES

The Contractor shall have sufficient resources, including but not necessarily limited to crews, subcontractors, equipment and materials, to concurrently perform work on a minimum of three (3) separate Expedited Work Orders, one (1) Non-Expedited Work Order, and one (1) Emergency Work Order, while allocating a minimum of one crew per work order.

Each bidder will be required to present satisfactory evidence that he has the necessary competency, capability, credit, integrity, perseverance and tenacity to complete this Contract as specified, to include providing information which delineates the number and type of each crew (pipe laying, testing, sodding, paving, etc.) to be allocated to this contract, the number of workers assigned to the crew and the company by whom they are employed. The inability to meet construction schedule deadlines for work order assignments shall be grounds for termination of the Contract.

S-5.01 LICENSES AND PERMITS

If not previously acquired by the Department, the Contractor must obtain at his own expense, all construction-related permits, licenses, or other legal authorization necessary for the execution of each project or work order issued by the Department. The Contractor must comply with all regulations, building and construction codes as may be required by law. Copies of all permits must be kept at the job site during construction. The Contractor shall comply with all the terms and requirements of the permits and will be held liable for the violation of any and all such permits.

Though generally not applicable to work orders to be issued through this Contract, where applicable (if project/work order work results in one acre or more of disturbed earth) the Contractor shall file a Notice of Intent (NOI) to access the generic NPDES permit administered by the Florida Department of

City-wide Meter, Hydrant and Valve Installation and Replacement
Contract 18-C-00030

Environmental Protection (FDEP). All document preparation, monitoring, reporting and other compliance with the NOI requirements shall be the responsibility of the Contractor and no separate payment shall be made.

If Hillsborough County right-of-way permit is required it will be obtained by the City - or alternately, the Contractor will be directed to complete the simple pdf-application and approval process with Hillsborough County, typically completed in a day or two. If an FDOT right-of-way permit is required it will be obtained by the City - or, if FDOT notification only is sufficient, the Contractor will be directed to notify FDOT of the impending work. For work to be performed within City of Tampa limits, the contractor shall apply for a City of Tampa right-of-way permit. The Contractor shall provide traffic control plans to all right-of-way owners as required

In addition to the license requirements of the Instructions to Bidders and as stated above, the Contractor or Subcontractor performing the work on any water/reclaimed water systems must hold a current State Underground Utility and Excavation Contractor License issued by the Construction Industry Licensing Board of the State of Florida.

S-6.01 LIQUIDATED DAMAGES

Due to the nature of the work, liquidated damages may be assessed. The Contractor will be given a reasonable length of time (as defined in the notice to proceed for each work order) to complete each separate work order, and is expected to complete the work expeditiously, including proper clean-up, and as-built drawings, within that period of time. If a work order is not completed within the time allotted in the work order's official schedule and Notice to Proceed (work order authorization), then the Department may deduct from the Contractor's payment for that work order, or from the payment of other work orders, \$500.00 per day for each calendar day that the work exceeds the allotted completion time. Also, and as noted in S-4.01, for all non-expedited work orders with an estimated value of \$50,000 or less, liquidated damages of \$500.00 per day will be assessed for each calendar day for which the Contractor fails to mobilize to the site and begin construction within twenty (20) calendar days of the start date delineated in the Notice to Proceed (work order authorization).

A work order that is substantially complete shall meet one of the following criteria:

- 1) All proposed installations and services (including meter transfers) are installed, tested and disinfected, such that water can be provided to consumers, and the roadway has been restored in such fashion that it is open to traffic, or
- 2) Proposed installations made (other than services direct to customers) are installed, tested and disinfected, such that the installations can be put into service and the roadway has been restored in such fashion that it is open to traffic.

The above definition shall govern, providing all applicable permits, codes and standards have been

complied with. Complete restoration is not necessary for a project to be substantially complete, however, final payment shall not be processed prior to final walk through with, and subsequent acceptance by, the Engineer. Final payment will not be processed until as-built drawings are provided and accepted by the Engineer.

S-7.01 WORK DIRECTIVE CHANGE

A Work Directive Change is a written directive to the Contractor, issued on or after the date of the execution of the Agreement, and signed by the Engineer on behalf of the City, ordering an addition, deletion or revision in the work, or responding to an emergency. A Work Directive Change will not change the contract price or the time for completion, but is evidence that the parties expect that the change directed or documented by a Work Directive Change will be incorporated in a subsequently issued Change Order following negotiations by the parties as to its effect, if any, on the contract price or the time of completion.

Without invalidating the Agreement, additions, deletions or revisions in the work may, at any time or from time to time, be authorized by a Change Order or a Work Directive Change. Upon receipt of any such document, the Contractor shall promptly proceed with the work involved.

S-8.01 ORDER AND TIME OF WORK

The work shall begin at such points as the Department shall designate and shall be prosecuted in the order it directs. This applies to both locations and items of construction. Where any of the work requires an interruption of service or water treatment plant operation, permission must be received from the Department and the work performed at times designated by it. The Contractor shall not be allowed to file claims for extra compensation of work prescribed by the Department. The Contractor shall make whatever arrangements are necessary and provide temporary lines and connections where designated by the Department.

S-9.01 DEFECTIVE MATERIALS

All pipe, fittings, valves, etc., except as defined herein, shall be furnished by the Contractor, and it shall be the responsibility of the Contractor to examine each item to ensure that it is new, unused, and in first class condition. Should a defect be discovered after the item has been placed in the trench, the replacement will be at the Contractor's expense. It will further be required of the Contractor that materials be hauled in a safe and careful manner to avoid possible damage. Should any damage be done, the Contractor shall be fully responsible. Materials may be stored along the installation routes in a manner acceptable to the Department. At no time shall materials for more than one weeks work be stacked in the right-of-way. Materials shall not remain in the right-of-way during week-ends, unless authorized by the Engineer. Contractor shall leave the site clean with no trash when workers are not present.

Any materials that are furnished by the Department to the Contractor shall be obtained at the Department's

storage yard. The Contractor shall furnish all labor and equipment necessary to load, transport, and unload the materials in the manner directed by the Department.

Materials accepted by the Contractor must be signed for by his authorized representative. After acceptance, the Contractor will be held accountable and responsible for the materials. No materials will be issued or returned without a written directive from the Department.

S-10.01 WORK PERFORMED ON SATURDAYS, SUNDAYS, LEGAL HOLIDAYS, OR AFTER REGULAR WORKING HOURS

With the exception of certain Emergency Work Orders issued, the work shall normally be discontinued on Saturdays, Sundays, all City and State designated holidays, and after regular working hours (7:30 A.M. to 4:00 P.M., Monday through Friday). Due to the work schedules of the City forces who may be involved, all work shall be conducted during normal work hours and days (Monday through Friday) and prior authorization must be requested by the Contractor for any work he feels is necessary to be accomplished on Saturdays, Sundays, or Holidays. Any overtime for Contractor convenience for weekend or holiday work requiring City forces will require reimbursement to the City by the Contractor for the cost of City personnel time required. The Contractor must request permission in writing at least 2 working days prior in order to perform work beyond regular work hours or on weekends or holidays as stated above. Written approval must be obtained from the Engineer.

When nighttime work has been approved or directed by the Engineer, it shall be the responsibility of the Contractor to provide adequate artificial lighting – additional compensation will be provided to the Contractor for said lighting, based on equipment rates in the current “Rental Rate Blue Book for Construction Equipment”. The Contractor shall be responsible for the safety of all employees during night work.

Jack and bore of FDOT maintained roadways must be started and completed during regular working hours of the FDOT's employees. Consequently, such operations must be initiated and completed in a continuous operation on Monday through Thursday when an FDOT inspector can be present.

S-11.01 COMMENCEMENT OF WORK

Upon receipt of the Contract Notice to Proceed, as specified in Tampa Agreement Article 4.01, the Contractor will be immediately authorized to receive work orders. The Contractor will be issued a separate work order authorization (notice to proceed for the work order) with each work order given to him. Non-Emergency work order authorizations shall stipulate the number of calendar days within which the Contractor must both commence and complete the work for the particular work order. The time for final completion shall be based on the approved work schedule for that particular work order.

Non-Expedited and Non-Emergency Work Order Work will not be allowed to commence until the Contractor has an approved project schedule, cost estimate and maintenance of traffic permit (if required).

S-12.01 PARTIAL PAYMENTS

The City shall have the option of making monthly partial payments on those work orders that exceed \$50,000.00. Payment of these partial payment requests shall be for the approved and accepted amount of work that the Contractor has accomplished in the previous month for that particular work order. The approved amount of work is defined as that amount of work associated with an active work order project which, in the opinion of the Engineer, is progressing at a satisfactory rate of completion. Satisfactory rate of completion is interpreted to mean that once a work order project is started by the Contractor, the job must be actively pursued to include site preparation, utility and agency coordination, installation of all pipe and appurtenances, restoration, clean up, all necessary testing, disinfecting, and final acceptance. Final acceptance shall include as-built drawings and necessary paperwork to close out the work order.

S-13.01 PUBLIC CONSTRUCTION BOND

Bidders who are awarded a Contract will be required to furnish a Public Construction Bond upon the form provided herein, in an amount at least equal to one hundred (100) percent of the full contract price, such Bonds to be issued and executed by (a) surety company(ies) acceptable to the City of Tampa and licensed to underwrite contracts in the State of Florida. Surety companies shall have a rating of not less than B+ (or better): Class VI (or higher) as evaluated in the most recently circulated BEST'S KEY RATING GUIDE PROPERTY-LIABILITY.

When the cumulative value of the work orders issued exceeds the value of the performance bond held by the City of Tampa, the Contractor shall promptly provide additional performance bond to cover 100% of the cumulative value of the work orders issued under this Contract. Any additional performance bonds required shall be submitted to the Engineer within five business days of receipt of the written work order (or as required for a contract renewal), and shall be reimbursed to the Contractor from the Contingency Allowance on the Contractor's next pay application.

At the conclusion of the contract, if the value of all work issued at that point in time is less than the value of the Contractor's original proposal (plus any contract renewals) the Contractor shall reimburse the City for the difference in the cost of the bond(s) for the original proposal (plus any contract renewals) versus the cost of the bond(s) to cover the actual work.

S-14.01 LAYOUT DATA

The City will provide horizontal and vertical control or reference points for each project, if required. From these control or reference points, the Contractor will set construction layout stakes and/or offsets necessary to complete the required work. All work shall be subject to field changes as directed by the Engineer. Compensation for construction layout will be included in the price of the various respective pay items for pipeline installation. Prior to commencement of construction, the Contractor shall obtain the Engineer's acceptance of the layout. It shall be the Contractor's responsibility to protect said stakes and/or offsets until (in the opinion of the Engineer) they have served their designated purpose. If re-staking and/or re-offsetting are required, the cost of re-staking and/or re-offsetting will be at the Contractor's expense.

S-15.01 CONFLICTS WITH PROPOSED WORK

It shall be the Contractor's responsibility to alert the Engineer to any conflicts or potential conflicts with the proposed work the day they are discovered, including but not limited to conflicts with existing utilities. Failure of the Contractor to review the job site and alert the Engineer to any conflicts shall relieve the Department from compensating the Contractor for any cost arising from any remedial action necessary to resolve conflict with the proposed work.

S-15.02 EXISTING UTILITIES

Any costs incurred as a result of damage to an “incorrectly” marked existing utility structure or appurtenances (except sanitary laterals – see S-20.01) are to be resolved with the owner of the damaged utility and are not the responsibility of the Water Department. “Incorrectly” marked (as defined in F.A.C. 556, the Underground Facility Damage Prevention and Safety Act) shall mean the hit location was more than 24” either side of the marking for 6” or smaller diameter pipe, or 24” outside of the marking (or double lines, if so marked) for pipes larger than 6” diameter.

S-16.01 TEMPORARY FACILITIES AND CONTROLS

A) Temporary Water Supply

In lieu of the requirements outlined in Article G-7.01 of the General Provisions, all reasonable amounts of water required by the Contractor for the construction under this Agreement will be furnished by the City from the existing water system without cost to the Contractor. The Contractor shall request temporary hydrant meters (at no charge to the Contractor) with backflow prevention devices when connecting to

City-wide Meter, Hydrant and Valve Installation and Replacement
Contract 18-C-00030

existing water system hydrants. A security deposit for the meter is required. The deposit will be returned when the meter is returned to the Contractor. City Crews will install the meter with backflow-preventer on the hydrant. The Contractor shall make any necessary water supply connections at his own expense at a point designated by the City. These connections shall be maintained by the Contractor, who shall furnish all pipe, valves, and such other equipment necessary or required. Temporary piping may run above ground when there is no possibility of traffic, and it can be done safely. Otherwise, it must run underground and in such manner as to meet the approval of the City. No water shall be wasted.

At the discretion of the City, unnecessary waste of water after notification will be cause for use of water to be discontinued. After temporary lines have served their purpose, they shall be removed by the Contractor and all connections closed or plugged to the satisfaction of the City.

B) Temporary Sanitary Facilities

Necessary sanitary conveniences for the use of all employees shall be erected and maintained in a satisfactory and sanitary condition, per G-7.03. Upon completion of the work they shall be removed leaving the premises clean.

C) Temporary Traffic Control

The Contractor shall arrange his work in order to obstruct traffic as little as possible. Maintenance of traffic (MOT) shall conform to the requirements of Articles G-10.01 and 10.02 of the General Provisions and all requirements stated herein. All applicable Federal, State, Local regulations and permit conditions will be adhered to. All MOT plans require approval from the right-of-way regulatory agency.

To protect persons from injury and to avoid property damage, adequate barrier walls, barricades, construction signs, torches, flashers, and guards as required shall be placed and maintained during the progress of the construction work and until it is safe to use the construction area for its normal purposes. Whenever required, the Contractor shall provide a watchman to prevent accidents. Rules and regulations of Local, State and Federal authorities in regard to safety provisions shall be observed. In addition, the installation of all mains and appurtenances shall comply with all requirements of the Occupational Safety and Health Administration (OSHA). The safety of the public and the work crews must be considered at all times. Because of the numerous conditions that must be considered, special traffic control planning must be made for each area within the construction limits.

In the absence of other regulatory requirements, the traffic control devices, the arrangement or position of the devices and the distances of the devices must be in conformance with the policies, procedures and regulations of the regulatory authority in charge of the right-of way or Part VI of the Manual on Uniform Traffic Control Devices (MUTCD), as a minimum standard. In FDOT rights-of-way, the MUTCD, the "Standard Specifications for Road and Bridge Construction" and the "FDOT Roadway and Traffic Design Standards for Design, Construction, Maintenance and Utility Operations on the State Highway System"

City-wide Meter, Hydrant and Valve Installation and Replacement
Contract 18-C-00030

shall be used. The Contractor shall not use fewer control devices, or reduce the signing, barricading or coning distances, to below these Minimum Standards. The Contractor is expected to expand or improve the installation whenever the need is indicated. Traffic movement through the work site is to be observed, and maintenance of all traffic control devices is expected during the construction period.

Prior to commencing work, the Contractor shall obtain permission from the appropriate Federal, State or local agency before construction starts and before making full or partial street closures, if such is allowed. When the appropriate agency requires plans for maintenance of traffic, the Contractor shall provide the necessary signed and sealed plans to the agency and to the Engineer. The Contractor shall be responsible for the re-routing of all traffic occasioned by the closure and will provide all necessary barricades, guards, signs, etc. If it becomes necessary to block vehicular or pedestrian access to private property, the Contractor shall prior to proceeding with the excavation, make arrangements acceptable with the owners or occupants and the Engineer.

S-17.01 MAINTENANCE AND RESTORATION OF JOB SITE

The Contractor shall conduct his operations in such a manner that will result in a minimum of inconvenience to occupants of adjacent homes and business establishments and shall provide temporary access as directed or as conditions in any particular location may require as determined by the Engineer. All restoration must be performed to an equal or better condition than that which existed prior to construction.

Good housekeeping on this project is extremely important and the Contractor will be responsible for keeping the construction site neat and clean, with debris being removed daily as the work progresses or as otherwise directed by the Engineer. Good housekeeping at the job site shall include: removing all tools and temporary structures, dirt, rubbish, etc.; hauling all excess dirt, rock, etc. from excavations to a dump provided by the Contractor; and all clean-up shall be accomplished to the satisfaction of the Engineer. Immediately after construction is completed in an area or part thereof (including restoration), barricades, construction equipment and surplus and discarded materials shall be removed by the Contractor.

In the event that the timely clean-up and restoration of the job site is not accomplished to the satisfaction of the Engineer, the Engineer may make arrangements to effect the necessary clean-up by others. The Contractor shall be back-charged for these costs. If such action becomes necessary on the part of and in the opinion of the Engineer, the Department shall not be responsible for the inadvertent removal from the work site of materials which the Contractor would not normally have disposed of had he affected the required clean-up.

At the completion of each workday, the Contractor shall fill all open trenches and pits. Trenches and pits may remain open only if the Contractor has obtained permission from the appropriate permitting agency and all protection and warning devices are in place in working order.

The Contractor shall replace all open-cut road pavements with a temporary compacted surface capable of

City-wide Meter, Hydrant and Valve Installation and Replacement
Contract 18-C-00030

supporting sustained vehicular loads as soon as possible once the trench or pit has been filled and compacted in 6-inch lifts. The temporary surface shall be maintained by the Contractor at the elevation of the adjacent road surfaces.

The Contractor is responsible for the security of all tools, materials and equipment required for this project and must make all arrangements for safeguards he may deem necessary. The City will assume no liability for any such security or losses resulting from lack of security.

S-18.01 CONTRACTOR'S SCHEDULE

The Contractor shall submit a weekly schedule to the Construction Engineer. The weekly schedule shall indicate his proposed water work plan for all outstanding projects in the forthcoming week. Such shall be delivered to the Construction Services office at 26th Avenue by noon of each Friday preceding the work plan week unless other arrangements have been made for this submittal.

S-19.01 USE OF EXPLOSIVES

Explosives shall not be used on the work except when authorized by the Engineer. If authorized, the use of explosives shall conform to laws or ordinances which may pertain to the use of same, and the utmost care will be exercised by the Contractor so as not to endanger life or property. The Contractor shall assume full responsibility in connection with the use of any explosives even though authorized. Explosives will not be stored within City limits.

S-20.01 SANITARY HOUSE CONNECTION CONFLICTS

Where sanitary house laterals are damaged or broken as a result of Contractor performed water or stormwater construction, such laterals shall be restored by the Contractor according to the City of Tampa Sanitary Sewer Department's specifications and to the satisfaction of the Engineer.

If City Wastewater forces were contacted (notified of impending construction) a minimum of two (2) full business days prior to the excavation that resulted in damage to the facility, and if the facility hit was marked incorrectly (meaning the hit location was more than 24" either side of the marking for 6" or smaller diameter pipe, or 24" outside of the double lines marked (if double lines were marked) for pipe larger than 6" diameter), then the Contractor shall receive compensation for the replacement based on the applicable unit rates provided in the Contract.

If the damaged lateral was correctly marked in the field by City Wastewater forces, no extra compensation shall be paid for this work.

Additional compensation for damaged lateral replacement is contingent upon Contractor compliance with SSOCOF guidelines for excavating. If determined that the Contractor's excavation was not in compliance

with SSOCOF Guidelines, additional compensation will not be allowed for the lateral replacement.

S-21.01 STREET AND TRAFFIC SIGNS

Removal and relocation of all street or traffic signs shall be approved through the City of Tampa Department of Public Works Traffic Engineering Division, Hillsborough County Traffic, Florida Department of Transportation, City of Temple Terrace or other applicable permitting agency.

S-22.01 GRADES AND DRAINAGE AT STREET INTERSECTIONS

The Contractor shall pay careful attention to the proper reconstruction of the pavement adjacent to the gutters and at street intersections to obtain satisfactory drainage to the inlets from the intersecting streets. Prior to construction, the Contractor shall determine the flow of water along a street, document where standing water is present.

S-23.01 LINES AND GRADES OF WATER MAIN INSTALLATION

In addition to requirements of Section 8 of the General Provisions, the Contractor is responsible for confirmation of the location of the pipe installation both horizontally and vertically where stated on the plans. These locations are indicated by station and offset. Any deviation from the plans shall be documented by confirmation of vertical and horizontal locations.

All elevations shall be referenced to the following datum:

North American Vertical Datum of 1988 (NAVD88)

NAVD88 is the vertical control datum established for vertical control surveying in the United States of America based upon the General Adjustment of the North American Datum of 1988. The NAVD 88 was established in 1991 by the minimum –constraint adjustment of geodetic leveling observations in Canada, the United States and Mexico. It held fixed the height of the primary tidal bench mark, referenced to the International Great Lakes Datum of 1985 local mean seal level height value, at Rimouski, Quebec, Canada. Additional tidal bench mark elevations were not used due to the demonstrated variations of seal surface topography, i.e., the fact that mean seal level is not the same equipotential surface at all tidal bench marks.

Current City of Tampa Datum (beginning in early 1970's) = NGVD29

Hillsborough County Datum = NAVD88

New FEMA Flood Maps Datum = NAVD88

There is no universal conversion between NGVD and NAVD88 because each datum is based upon an ellipse and the ellipses are not concentric. However, specific points can be converted from one datum to another using a software program (Corpscon 6.01) developed by the US Army Corps of Engineers.

Note: The Contractor is to use existing as-built drawings cautiously as the drawings may have been prepared using the NGVD 29.

S-24.01 NOTICE AND SERVICE THEREOF

All notices, which shall include demands, instructions, requests, approvals, and claims, shall be in writing.

Any notice to or demand upon the Contractor shall be sufficiently given if delivered to the office of the Contractor specified in the bid (or to such other office as the Contractor may, from time to time, designate to the Department in writing), or if deposited in the United States mail in a sealed, postage-prepaid envelope, or delivered, with charges prepaid, to any telegraph company for transmission, in each case addressed to such office.

All notices required to be delivered to the Department shall, unless otherwise specified in writing to the Contractor, be delivered to the Engineer, Tampa Municipal Office Building, 5th Floor East Wing, City Hall Plaza, Tampa, Florida 33602, and any notice to or demand upon the Department shall be sufficiently given as delivered to the office of the Engineer, or if deposited in the United States mail in a sealed, postage-prepaid envelope, or delivered with charges prepaid to any telegraph company for transmission, in each case addressed to said Engineer or to such other representative of the Department or to such other address as the Department may subsequently specify in writing to the Contractor for such purposes.

Any such notice or demand shall be deemed to have been given or made as of the time of actual delivery or (in the case of mailing) when the same should have been received in due course of post or (in the case of telegram) at the time of actual receipt, as the case may be.

S-25.01 REQUIREMENTS FOR CONTROL OF THE WORK

Prior to the start of non-expedited or non-emergency work order work included in this contract, a preconstruction conference will held by the Engineer to be attended by the Contractor and representatives of the various utilities and others for the purpose of establishing a schedule of operations which will coordinate the work to be done under this contract with all related work to be done by others within the limits of the project. The Contractor shall be prepared for this meeting. He shall present the official construction schedule for all items of work to be accomplished by him, which will be used as a basis for the development of an overall operational schedule.

The progress of work order work will be reviewed by the Engineer at the end of each week against the approved official schedule or L.O.S. expected for that work order. If the overall progress of work for that work order is found to be unsatisfactory, the Contractor shall adjust the rate of progress on those items necessary to ensure timely completion of the entire work order.

City-wide Meter, Hydrant and Valve Installation and Replacement
Contract 18-C-00030

The Contractor shall conduct his operations in such a manner as will result in a minimum of inconvenience to occupants of adjacent homes and business establishments and shall provide temporary access as directed or as conditions in any particular location may require as determined by the Engineer.

Dust shall be minimized as stated in G-10.06 of the General Provisions. During this Contract, the Contractor, through the use of water and other approved means, shall institute a continuous dust abatement program to the extent that reasonable precaution shall be taken by the Contractor to minimize the emission or particulate matter into the air. Dust control measures shall be acceptable to the Engineer.

Noise from construction operations shall be minimized in accordance with G-10.04 of the General Provisions.

The Contractor shall provide for satisfactory disposal of surplus water and shall submit a plan to the Engineer for his review prior to initiation and implementation of the plan. Prior approval shall be obtained from the proper authorities for the use of public or private lands or facilities for such disposal.

S-26.01 ENVIRONMENTAL PROTECTION

The Contractor will be held liable for the violation of any and all environmental regulations and permit conditions. Violation citations related to environmental regulations and permit conditions carry civil penalties and, in the event of willful violation, criminal penalties. The fact that the permits are issued to the City does not relieve the Contractor in any way of his environmental obligations and responsibilities.

The Contractor shall evaluate and assess the impact of any adverse effects on the natural environment which may result from construction operations and shall operate to minimize pollution of air, ground or surface waters and vegetation and afford the neighboring community the maximum protection during and upon completion of the construction. The Contractor shall comply with Article 14.01 of the General Provisions and submit a plan to the Engineer for review and acceptance prior to implementation of the plan. Such plan can be combined with other control plan submittals and shall address protective measures to be taken along the route during pipeline construction.

The Contractor shall take sufficient precautions to prevent pollution of streams, lakes, ponds and other water sources with fuels, oils, bitumen, calcium hypochlorite (HTH) or other harmful materials. He shall conduct and schedule his operations so as to avoid pollution or siltation of streams, lakes, etc., including the use of silt barriers, straw bales or other related control methods, as outlined in the FDOT Standard Specifications. Where there is a high potential for erosion, the Contractor shall not expose, by construction operations, a larger area of erosive land at any one time than the minimum necessary for efficient construction operations, and the duration of exposure of the uncompleted construction to the elements shall be as short as practicable. Erosion control features shall be constructed concurrently with other work and at the earliest practicable time.

S-27.01 USE OF PRIVATE PROPERTY

In accordance with Section 10, Paragraph G-10.07 of the General Provisions, all construction activities required to complete Work Order Work in accordance with the plans and specifications shall be confined to public rights-of-way, unless the Contractor makes specific arrangements with private property owners for his use of their property. The City assumes no responsibility for damage to private property in such instances. The Contractor is responsible for protection of private property abutting the work areas on this project.

S-28.01 TREE REMOVAL

The Contractor shall be extremely careful and make all efforts to preserve existing trees, plants, and shrubs within the construction area.

Any existing trees, plants, and shrubs to be removed shall be with the prior approval of the Engineer and in accordance with City of Tampa Landscape Ordinance No. 89-262, latest edition, or the requirements of the local agency responsible for overseeing those activities. Separate payment shall be made to the Contractor for the tree removal under the appropriate pay item.

S-29.01 STANDARD DETAILS

In addition to the various details applicable to the project included in the plans, there are Standard Details of the City of Tampa Water Department that shall apply to this work. The details that are to supplement those shown in the plans are included herein.

S-30.01 MAINTENANCE OF CONTINUOUS WATER SERVICE

At the conclusion of every work day, the Contractor is responsible for ensuring that all water services within his effective work area are in service. If a water customer contacts the Department to advise that they have no water service and it is determined to be within the Contractor's work area, the Contractor will be notified of the interrupted service through the Department dispatcher and/or inspection division. Upon notification, the Contractor must mobilize to the site and reinstate the customer's water service.

If the Contractor fails to mobilize his forces to make the repairs, the Department will mobilize its own forces to reinstate the customer's water services. In this event, the Contractor shall be charged a five hundred dollar (\$500.00) flat rate fee plus actual direct department costs for labor, materials, and equipment used to reinstate the water service. This five hundred-dollar fee and Department cost will be charged for each additional service reinstated. The amount charged will be deducted from the Contractor's payment.

S-31.01 SHUTDOWNS

Unless otherwise approved by the Engineer in an emergency situation, scheduled shutdowns may only occur on Mondays, Tuesdays and Wednesdays. The Contractor shall notify the Engineer at least two weeks in advance of the need for a scheduled shutdown.

Where connections are made to the existing mains, or where other occurrences require a shutdown, the Contractor shall work with the City to perform the work necessary to complete the shutdown. The City will make every effort in advance to perform pre-valve shutdowns, but there are no guarantees as to whether or not all valves will properly seat in order to guarantee a complete shutdown. In the event of an emergency, the Contractor shall immediately notify the City.

S-32.01 GUARANTEES, WARRANTIES, BONDS

The Contractor, together with his Surety, shall guarantee all the work furnished under the Agreement for a period of one full year from the date of final acceptance, as outlined in Article 6.04 of the Agreement, or within such longer period of time as may be prescribed by law, or by special guarantee or provision of the Contract Documents. Under this guarantee, the Contractor agrees to make good without delay, at his own expense, any failure of any part of the work due to faulty materials or manufacture, or the failure of any equipment furnished to perform satisfactorily all the work within the limits of the Agreement. He will also make good any damage caused by such failure. Any such repair work shall receive a similar guarantee for a similar period of time. This guarantee shall be exclusive of manufacturer's guarantees or warranties exceeding this period.

S-33.01 WORKER SAFETY

The Contractor shall comply with all requirements in OSHA 29 CFR 1910.146 and FAC 38I 20.035 for confined spaces and confined space entry.

S-34.01 ASBESTOS REMOVAL

The Contractor shall secure the services of a State of Florida licensed asbestos abatement contractor for the performance of any and all work involving the cutting, removal, transportation and proper disposal of asbestos containing materials.

The asbestos abatement work must be performed by a contractor having not less than 10 years of experience in work of this type and magnitude. The asbestos abatement contractor must submit a listing of the last ten (10) projects performed with the name and telephone number of a contact person. Additionally, the asbestos abatement contractor shall submit a certified letter indicating compliance with the following:

- a) Job supervisor's names and confirmation of State of Florida licensure, valid for the period of the contract.

- b) Pollution Liability Insurance with a minimum limit of \$1,000,000 bodily injury and property damage combined single limit each occurrence to cover its liability as an asbestos abatement contractor. Such policy shall be issued in accordance with the insurance specifications contained in this bid, including naming the City and Contractor (if different than the asbestos abatement contractor) as additional insureds.
- c) Statements indicating no pending lawsuits.
- d) An acceptable disposal facility is required. Documentation must be submitted to the City Engineer that the proposed disposal site is approved to receive and deposit asbestos waste materials. After deposition, receipts must be submitted to the Engineer to demonstrate that the waste was properly disposed of.

The submittal shall be in sufficient detail to show compliance with the above qualification specification.

S-35.01 PROJECT SIGN

At the direction of the Engineer, the Contractor may be required to furnish and install a project sign for each non-expedited work order. The Engineer shall also delineate the location and orientation for the sign. The sign shall satisfy all provisions of the Contract documents and compensation will be as outlined in the appropriate pay item descriptions. The Contractor may be required to reletter and reuse an existing sign from a previous work order.

S-36.01 CONTRACTOR'S PRESENCE

The Contractor or his authorized representative shall be present at the job site at all times while the work is in progress. Contractor shall make readily accessible copies of both the Contract Documents and the latest approved working drawings at the job site.

S-37.01 FIELD OFFICE

Field offices will not be required per G6.03 as most of the work required will be in City streets.

S-38.01 TEMPORARY FENCING

Whenever temporary site fencing is required per contract plans, the fencing will be added to the project through a change order. Temporary fencing is not required on every work order.

S-38.02 PERMANENT FENCE RESTORATION

When required to remove permanent fence to permit construction, the Contractor shall remove and store fence to prevent damage. Subsequent to construction, the Contractor shall restore fence to its original location and condition, repair damaged fence, or replace with applicable in-kind material.

Whenever permanent fencing is agreed by the Engineer to be removed by the Contractor to facilitate water construction, fence removal and restoration shall be performed per G-9.04 – except compensation will be provided to the Contractor, based on either 1) the fencing sub-contractor’s invoice, plus 10% OH&P; or, 2) if fence restoration is executed by the Contractor, compensation shall be provided in accordance with Specific Provision S-4.04. The fence restoration will be added to the project through a Work Directive Change (WDC). Permanent fencing is not required on every work order.

S-39.01 VALVE OPERATIONS ON NEW WATER MAINS

Valve operated on new mains that have been connected to the City of Tampa water distribution system in order to flush and clear lines are to be opened and closed very slowly. Damages to the existing water system due to Contractor(s) closing valves on the new main too quickly will be assessed to the Contractor.

S-40.01 PEDESTRIAN FACILITIES

- A. All pedestrian facilities shall be reconstructed in accordance with the Americans with Disabilities Act (ADA) and the Department of Transportation Regulation 49 CFR, Part 37.
- B. Sidewalks and curb ramps shall be reconstructed in accordance with the FDOT Design Standards 2010 (or the latest edition at time of bid opening) Index 304. Residential sidewalks adjacent to driveways shall be six (6) inches depth up to the first construction joint, which shall be a distance of five (5) feet measured from the edge of the driveway. Sidewalks/Ramps adjacent to roadways shall be six (6) inches in depth up to the first construction joint which shall be a minimum distance of six (6) feet measured from the edge of pavement, or back of curb. The construction joint may not transect the detectable warning surface.
- C. Detectable warning surfaces, as defined by the latest edition of FDOT Standard Specifications for Road and Bridge Construction - Specification 527, will be utilized in lieu of tactile surfaces. Detectable warning surfaces must be capable of supporting vehicular traffic and no waivers to the warranty are acceptable. All references to tactile surfaces in the City’s Specifications for construction shall be interpreted as referring to detectable warning surfaces. In order to meet ADA visual contrast requirements, the standard color for application on maintained roads is red, unless otherwise directed by the Engineer. If field conditions exist in which red would not create sufficient contrast, the Engineer should be notified in order to determine if another color should be utilized.

On FDOT maintained roads, the color requirements may vary and should be confirmed prior to placement.

Acceptable Materials for Detectable Warning Surfaces:

1. Proprietary epoxy-based system supplied and installed by Vanguard of Florida.
2. Alternate materials and methods which fully meet contract specifications, and which have been approved for the FDOT Qualified Products List, may be used if approved by the Project Manager.

S-41.01 RECORD DRAWINGS

The CONTRACTOR shall keep at the Site and in good order one record copy of the Contract Documents and the Shop Drawings. The contract documents shall be annotated (red-lined) on a continuing basis to show all changes made during the construction process. These shall be available to the Engineer or his designated representative and shall be submitted for City's acceptance prior to Substantial Completion. Final payment shall be dependent on the City's acceptance and approval of record drawings or close-out paperwork required for each work order issued.

S-42.01 PLANSHEETS

There are no external plan sheets on this bid.

* * *

CONTRACT PAY ITEMS

C1.00 General

The Contractor shall receive and accept the compensation provided in the Proposal and the Agreement as full payment for furnishing all materials and all labor, tools and equipment, for performing all operations necessary to complete the work under the Agreement, and also in full payment for all loss or damages arising from the nature of the work, or from any discrepancy between the actual quantities of work and quantities herein estimated by the Engineer, or from the action of the elements or from any unforeseen difficulties which may be encountered during the prosecution of the work until the final acceptance by the Department.

It is the intent of these contract documents that any cost for which compensation is not directly provided by a bid item shall be prorated and included in the bid item for which they are required. Failure of the Contractor to follow this procedure shall be basis for rejection of his bid.

The prices stated in the Bid Proposal include all costs and expenses for taxes, labor, equipment, commissions, transportation charges and expenses, patent fees and royalties, labor for handling material during inspection together with any and all other costs and expenses for performing and completing the work as shown on the plans and specified herein. The basis of payment for any item at the unit price shown in the Proposal shall be in accordance with the description of that item in this Section.

No separate payment will be made for the following items; the cost of such work shall be included in the applicable contract pay items of work, including separate mobilization/demobilization charges for compliance with FDEP or any other agency:

1. Separate mobilization charges for each work order except as noted in Section C9.96;
2. Clearing and grubbing;
3. Excavation, including necessary pavement/slab removal;
4. Shoring and sheeting as required by OSHA trench excavation safety standards unless specifically provided for in a pay item;
5. Dewatering and proper disposal of all water unless specifically provided for in a pay item;
6. Backfill and proper compaction, including suitable fill;
7. Grading;
8. Replacement or restoration of paved or unpaved roadways, grass and shrubbery plots outside of established pay limits;
9. Temporary facilities and controls during construction such as water/sanitary facilities, traffic control, informational signs and environmental protection, unless specifically provided for in a pay item;
10. Providing and maintaining silt barriers for drainage structures and silt fences for the duration of the project;
11. Removing and legally disposing of waste material due to construction, including but not limited to

City-wide Meter, Hydrant, and Valve Installation and Replacement
Contract 18-C-00030

- valve boxes that need to be removed from abandoned water mains;
12. Cleanup and restoring the job site to its original condition, which includes but is not necessarily limited to restoring the ground surface to its original grade;
 13. Testing and placing system in operation, including re-mobilization for FDEP testing;
 14. Any material and equipment required to be installed and used for the tests;
 15. Maintaining the existing quality of service during construction, including flushing mains that are cleared but not put into service after the bacteriological (bac-T) tests are complete;
 16. Repair of sanitary sewer house laterals that were properly marked (see Specific Provision S-20.01)
 17. Repair of water services damaged during construction;
 18. Adjusting new or existing water meter boxes to grade which are affected by construction;
 19. Appurtenant work as required for a complete and operable system;
 20. Coordination with all utilities and all Federal, State and Local agencies;
 21. Cutting of existing or new pipe for purposes of abandonment or installation of new pipe, valves or fittings;
 22. Tree trimming as required by the City of Tampa Parks Department or any other agency unless specifically provided for as a contract item;
 23. Verification of pipe elevation as stated in Section 8 of the General Provisions and Section S-23.01 the Specific Provisions;
 24. Repair of private irrigation systems damaged during construction;
 25. Furnishing and installing suitable temporary fences, as directed by the Engineer, to adequately secure areas protected by a permanent fence when that permanent fence must be removed. The temporary fence shall remain in place until the permanent fence is replaced;
 26. Furnishing and installing all HDPE MJ adapters, HDPE flanged adapters, HDPE electrofusion tapping tees, electrofusion corporation saddles or HDPE electrofusion couplings;
 27. Maintaining red-line drawings of changes to construction plans, to be submitted for FDEP clearance;
 28. Furnishing record drawings based on the redline drawings in AutoCAD 2015 or higher and one set of drawings on paper. The City will provide the AutoCAD plans used for the design. **Final Payment will not be made for work orders until as-built drawings are received and accepted by the City.**
 29. Furnishing and installing polyethylene encasement per Standard Detail 2.05 for all buried ductile iron pipe, all fittings and tapping sleeves.

The Contractor's attention is again called to the fact that the quotations for the various items of work are intended to establish a total price for completing the work in its entirety. Should the Contractor feel that the cost for any item of work has not been established by the Proposal or Contract Pay Items, he shall include the cost for that work in some other applicable bid item, so that his proposal for the project does reflect his total price for completing the work in its entirety.

The Contractor may be authorized to receive payment after each work order is complete, approved, accepted, and administratively processed by the City.

City-wide Meter, Hydrant, and Valve Installation and Replacement
Contract 18-C-00030

The City shall have the option of making monthly partial payments on those work orders that exceed \$50,000.00. Payment of these partial payment requests shall be for the approved and accepted amount of work that the Contractor has accomplished in the previous month for that particular work order. The approved amount of work is defined as that amount of work associated with an active work order project which, in the opinion of the Engineer, is progressing at a satisfactory rate of completion. Satisfactory rate of completion is interpreted to mean that once a work order project is started by the Contractor, the job must be actively pursued to include site preparation, utility and agency coordination, installation of all pipe and appurtenances, restoration, clean up, testing, disinfection, and final acceptance.

Following final payment by the City, the Contractor shall maintain the surface of the unpaved trenches, shrubbery, fences, sod, and other surfaces disturbed for a period of one (6) months thereafter and shall maintain the repaved areas, curbs, gutters and sidewalks, trees, if replaced by the Contractor, for one (1) year after acceptance. The cost of maintaining the restored areas is considered incidental to the cost of restoring the areas disturbed by the Contractor. These costs shall be prorated and included in the cost for the bid item for which it is required.

The quantities for payment under this Agreement shall be determined by actual measurement of the completed items, in place, ready for service and accepted by the City, in accordance with the applicable method of measurement therefore contained herein. A representative of the Contractor shall witness all field measurements.

All work shall be in accordance with the Technical Specifications and Standard Details herein. All materials shall be in accordance with the Material Specifications herein.

C2.00 Pipeline Installation

C2.10 Ductile Iron and PVC Pipe via Open-cut

The Contractor shall provide all labor, equipment, and materials to furnish and install the ductile iron pipe or PVC pipe.

Furnishing and/or installing ductile iron or PVC pipe shall include, but may not be limited to:

1. Furnishing all construction layouts as outlined in Section S-14.01 and S-23.01;
2. Field locating all utilities to confirm horizontal and vertical location in areas of possible conflict;
3. Furnishing all labor equipment and materials to excavate the trench;
4. Maintaining the trench which shall include dewatering and sheeting and bracing as required by OSHA or as directed by the Engineer standards unless specifically provided for in a pay item;
5. Cleaning dirt and foreign material from within pipe and bell;
6. Beveling field-cut joints and pipe shorts;
7. Furnishing and installing EPDM gaskets for all DIP and PVCP;
8. Furnishing and installing Department approved pipe and any pipe shorts as part of the pipeline;

City-wide Meter, Hydrant, and Valve Installation and Replacement
Contract 18-C-00030

9. Furnishing and installing Department approved pipe in casing pipe when shown on the plans;
10. Installing push-on joint restraint gaskets for DIP as shown on the plans or as directed by the Engineer (furnishing push-on restraint gaskets will be compensated under appropriate pay items);
11. Furnishing and installing blue polyethylene encasement for D.I. Pipe and Fittings, per standard Detail 2.05;
12. Furnishing and installing 2-, 4-, 6-, 8-, 12-, and 16-inch nominal diameter PVC pipe or 4-, 6-, 8-, 12-, 16-inch nominal diameter ductile iron pipe at various depths;
13. Furnishing and installing 2-inch PVC fittings when necessary at various depths;
14. Furnishing and installing on all PVC pipe and fittings, a continuous double-run of 12-gauge CCS tracer wire attached to the top of the pipe with duct tape. The wire shall be looped around each bell. There shall be no dead ends, and the locator wire shall be brought into tracer wire boxes installed within a valve box's concrete pad, in an isolated concrete pad (if no valve present), or in asphalt without a concrete pad. Tracer wire for direct bury installations shall be approved insulated copper clad steel (CCS) wire such as Copperhead High Strength Tracer Wire or Pro-Trace HF-CCS PE45 Tracer Wire. Wire splices must be with wire connectors suitable for buried service, and be corrosion and moisture-proof, such as DBR Kit by 3M, Snakebite by Copperhead Industries or equal;
15. Cleaning up and removing excess water main pipe and appurtenances;
16. Pressure testing the water main pipe;
17. Furnishing and installing temporary pipe shorts, valves and bends for full port flushing;
18. Furnishing and installing valve location protection devices per Standard Detail 3.05 whenever needed to keep valve locations visible;
19. Disinfecting the water main pipe and bacteriological testing;
20. Furnish and apply paint for any above ground or aerial crossing pipe and appurtenances. Paint to be high-grade enamel, OSHA blue for potable water or purple for reclaim water as directed by the Engineer;
21. Backfilling and compacting the trench;
22. Cleaning up and restoring the job site which shall include re-grading the terrain; and
23. Removing and legally disposing all waste materials.
24. Furnishing and installing 10-gauge tracer wire on ductile iron water mains 16" diameter and larger. Wire shall be double-strand, with the ends of each wire terminating in tracer wire boxes, per Detail 3.02.

Cover over pipe shall be defined as the vertical distance from the top of the pipe to the surface grade above the main. Trench depth shall be defined as the vertical distance from the bottom of the barrel of the pipe to the surface grade above the main.

Payment for connecting new water mains to existing water mains will be made utilizing the contract unit price for installing the fittings, polywrap, or valves used in the connection.

The cost to hydrostatically test and disinfect the ductile iron or PVC water mains shall be prorated and included in the pipeline construction unit prices. The prorated cost should include, but may not be limited

City-wide Meter, Hydrant, and Valve Installation and Replacement
Contract 18-C-00030

to furnishing and installing all:

- 1) Material;
- 2) Labor;
- 3) Necessary pumps;
- 4) Recorder charts;
- 5) Gages (300PSIG limit, oil filled);
- 6) Chemicals;
- 7) Temporary valves;
- 8) Temporary plugs;
- 9) Sample taps, (including installation of brass dry main plugs after tap removal);
- 10) Blow off assemblies (including removal after disinfection is complete);
- 11) Dry main plugs.

necessary to pressure test and disinfect various sizes and depths of ductile iron pipe or PVC pipe. Furthermore, no extra compensation shall be paid to the Contractor for:

1. Furnishing and installing brass, dry main plugs at the locations of all removed sample taps, or
2. Removing existing "end of line" or blow-off valves after the pipeline has been disinfected and prior to connecting the newly installed pipeline to the existing water main.

All temporary materials or materials not remaining in the ground after the completion of the disinfection and pressure testing shall remain the property of the Contractor.

The pipe quantities to be paid for under this section shall be based on the size and the horizontal distance in linear feet of ductile iron pipe, PVC pipe, or steel casing pipe measured along the top centerline of the pipe in place complete and acceptable to the Engineer.

Payment shall be made under:

<u>Item No.</u>	<u>Description</u>	<u>Unit</u>
2100	Furnish and install 4" ductile iron pipe	LF
2102	Furnish and install 6" ductile iron pipe	LF
2104	Furnish and install 8" ductile iron pipe	LF
2105	Furnish and install 10" ductile iron pipe	LF
2106	Furnish and install 12" ductile iron pipe	LF
2108	Furnish and install 16" ductile iron pipe	LF
2149	Furnish and install 2" PVC pipe and fittings at various depths	LF
2150	Furnish and install 4" PVC pipe	LF
2152	Furnish and install 6" PVC pipe	LF
2154	Furnish and install 8" PVC pipe	LF

City-wide Meter, Hydrant, and Valve Installation and Replacement
Contract 18-C-00030

2156	Furnish and install 12" PVC pipe	LF
2158	Furnish and install 16" PVC pipe	LF
2160	Furnish and install 4" restrained jt. PVC pipe by open cut	LF
2162	Furnish and install 6" restrained jt. PVC pipe by open cut	LF
2164	Furnish and install 8" restrained jt. PVC pipe by open cut	LF
2166	Furnish and install 12" restrained jt. PVC pipe by open cut	LF
2168	Furnish and install 16" restrained jt. PVC pipe by open cut	LF

C2.20 Furnish and Install HDPE and PVC Pipe by Horizontal Directional Drilling

The Contractor shall provide all labor, equipment, and materials to furnish and install the HDPE and PVC pipe using horizontal directional drilling (HDD) as a work method. The furnishing and installation of the HDPE and PVC pipe shall include, but may not be limited to:

1. Furnish and install construction layout by a registered professional land surveyor;
2. Field locating all utilities, except existing water lines not shown properly on the plans, to confirm horizontal and vertical location in areas of possible conflict;
3. Excavating the access pits;
4. Maintaining the pits which shall include dewatering and sheeting and bracing as required by OSHA or as directed by the Engineer;
5. Joining HDPE pipe sections by butt fusion or by furnishing and installing an appropriately sized HDPE electrofusion coupling;
6. Pigging, cleaning or flushing the line to remove dirt, debris if directed by the engineer;
7. Furnishing and installing temporary valve, pipe shorts and bends to accomplish full port flushing of mains;
8. Furnishing and installing Department approved pipe and any pipe shorts as part of the pipeline;
9. Furnishing and installing 4-, 6-, 8-, 10-, 12-, and 14-inch nominal diameter HDPE and PVC pipe and 2-inch HDPE tubing at various depths by horizontal directional drilling;
10. Furnishing and installing on all HDPE pipe/tubing and PVC pipe two continuous 10-gauge wires along the top of the pipe. There shall be no dead ends, and each locator wire shall be brought into tracer wire boxes installed within a valve box's concrete pad, in an isolated concrete pad (if no valve present), or in asphalt without a concrete pad. Connections between wire ends shall be made using an approved connection as shown in the standard details;
11. Tracer wire for directional drill installations shall be approved insulated copper clad steel (CCS) wire such as Copperhead SoloShot Extra HS or Pro-Trace HD-CCS PE45. For directional drilled HDPE pipe, a 1" conduit may be pulled back with the locating wires to ease installation and to prevent the wires from breaking. Wire splices made must be with wire connectors suitable for buried service and be corrosion and moisture-proof, such as DBR Kit by 3M, Snakebite by Copperhead Industries or equal;
12. Removing ancillary water main pipe and/or appurtenances;
13. Pressure testing the water main pipe;
14. Disinfecting the water main pipe;

City-wide Meter, Hydrant, and Valve Installation and Replacement
Contract 18-C-00030

15. Backfilling and compacting the trenches or pits including re-grading the terrain;
16. Cleaning up and restoring the job site which shall include re-grading the terrain; and
17. Removing and legally disposing of all waste materials.

Cover over pipe shall be defined as the vertical distance from the top of the pipe to the surface grade above the main. Trench depth shall be defined as the vertical distance from the bottom of the barrel of the pipe to the surface grade above the main.

Payment for connecting new water mains to existing water mains will be made utilizing the contract unit price for installing the tapping sleeves, restraints, fittings or valves used in the connection.

The cost to hydrostatically test and disinfect the water mains shall be prorated and included in the pipeline construction unit prices. The prorated cost should include, but may not be limited to furnishing and installing all:

- 1) Material
- 2) Labor
- 3) Necessary pumps
- 4) Recorder charts
- 5) Gages (200 PSIG limit, oil filled)
- 6) Chemicals
- 7) Temporary valves
- 8) Temporary plugs
- 9) Sample Taps, (including furnishing and installation of brass dry main plugs in corporation saddles after sample tap removal)
- 10) Blow off assemblies (including removal after disinfection is complete)
- 11) Dry main plugs installed in the corporation saddles.

necessary to pressure test and disinfect various sizes and depths of HDPE pipe. Furthermore, no extra compensation shall be paid to the Contractor for:

1. Furnishing and installing brass, dry main plugs in HDPE electrofusion corporation saddles at the locations of all removed sample taps, or
2. Removing existing "end of line" or blow off valves after the pipeline has been disinfected and prior to connecting the newly installed pipeline to the existing water main.

All temporary materials or materials not remaining in the ground after the completion of the disinfection and pressure testing shall remain the property of the Contractor.

The pipe quantities to be paid for under this section shall be based on the size and the horizontal distance in linear feet of HDPE pipe measured along the top centerline of the pipe in place complete and acceptable to the Engineer.

City-wide Meter, Hydrant, and Valve Installation and Replacement
Contract 18-C-00030

Payment shall be made under:

<u>Item No.</u>	<u>Description</u>	<u>Unit</u>
2200	Furnish & install 2" HDPE tubing w/HDPE transition adapters at various depths	LF
2201	Furnish & install 4" HDPE pipe at various depths	LF
2202	Furnish & install 6" HDPE pipe at various depths	LF
2203	Furnish & install 8" HDPE pipe at various depths	LF
2204	Furnish & install 10" HDPE pipe at various depths	LF
2205	Furnish & install 12" HDPE pipe at various depths	LF
2206	Furnish & install 14" HDPE pipe at various depths	LF
2207	Furnish & install 6" RJPVC pipe by HDD at various depths	LF
2208	Furnish & install 8" RJPVC pipe by HDD at various depths	LF
2212	Furnish & install 12" RJPVC pipe by HDD at various depths	LF
2216	Furnish & install 16" RJPVC pipe by HDD at various depths	LF

C2.30 Temporary Service Lines

The Contractor shall provide all labor, equipment and materials necessary to furnish, install and remove temporary 2-inch service lines, connect the existing meters to the temporary service lines, and remove and dispose of all waste materials. The cost to reconnect the meters to the new mains will be paid under the appropriate meter set item.

Work shall include but may not be limited to:

1. Making all necessary excavations;
2. If necessary, burying the pipe to prevent a tripping hazard or securing the pipe to prevent damage during construction;
3. Making necessary taps to existing main or service line;
4. Making all necessary taps (2 may be required) that are required to affect the tie-in connection;
5. Furnishing and installing all necessary materials required to make the tie-in connections;
6. Furnishing and installing 2-inch high density polyethylene (HDPE) tubing; and
7. Furnishing and installing cap(s) or plug(s) and restraints adequate to withstand a working pressure of 150 psi, on all in-service open end(s) of pipe;
8. Furnishing all labor equipment and materials to remove the temporary service when no longer needed;
9. Backfilling, compacting, and re-grading the terrain;
10. Cleaning up and restoring the job site which shall include re-grading the terrain; and
11. Removing and legally disposing of all waste materials.

<u>Item No.</u>	<u>Description</u>	<u>Unit</u>
-----------------	--------------------	-------------

2300 Furnish, install and remove 2-inch temporary service lines LF

C2.40 Casing Installation

The Contractor shall provide all labor, equipment and materials to furnish and install steel casing pipe. The installation of steel casing pipe shall include, but may not be limited to:

1. Excavating the jacking and recovery pits;
2. Maintaining the jacking and recovery pits that shall include dewatering and sheeting and bracing where required or as directed by the Engineer;
3. Dewatering the roadway;
4. Furnishing, cutting and full depth welding the steel casing pipe;
5. Jacking the steel casing pipe;
6. Furnishing and installing the pipe "casing spacers" on the carrier pipe;
7. Furnishing and installing bulkheads inside the casing pipe ends to seal the inner space;
8. Backfilling and compaction of jacking and recovery pits;
9. Cleaning up and restoring the job site which shall include re-grading the terrain; and
10. Removing and legally disposing all waste materials.

Compensation for installing the carrier pipe in the casing pipe will be made under the appropriate pipeline construction pay item. The Engineer can exercise his authority and elect to have the Contractor install only the casing pipe, thereby waiving installation requirements for the carrier pipe.

Payment shall be made under:

<u>Item No.</u>	<u>Description</u>	<u>Unit</u>
2400	Furnish and install 4" OD steel casing pipe	LF
2401	Furnish and install 12" OD steel casing pipe	LF
2402	Furnish and install 14" OD steel casing pipe	LF
2403	Furnish and install 16" OD steel casing pipe	LF
2404	Furnish and install 20" OD steel casing pipe	LF
2405	Furnish and install 24" OD steel casing pipe	LF

C2.50 Removal and Abandonment of Pipe

The Contractor shall provide all labor, equipment and materials to remove the abandoned pipeline and appurtenances (such as valves, fittings, and other materials) as designated on the plans or directed by the Engineer.

The removal of the abandoned pipe shall include, but may not be limited to:

City-wide Meter, Hydrant, and Valve Installation and Replacement
Contract 18-C-00030

1. Furnishing all equipment, labor, tools and equipment to excavate the trench;
2. Maintaining the trench;
3. Removing the abandoned pipeline and appurtenances;
4. Furnishing and installing a restrained cap to plug any abandoned open-end pipe;
5. Furnishing and installing a cap or plug and restrain adequately to withstand a working pressure of 150 psi, on all pipe ends remaining in service;
6. Transporting the removed pipe and appurtenances, without delay, to a location designated by the Engineer;
7. Unloading the removed pipeline and appurtenances at the designated location;
8. Cutting of any existing pipe to accommodate abandonment;
9. Backfill and compacting the trench;
10. Cleaning up and restoring the job site which shall include re-grading the terrain; and
11. Removing and legally disposing of all waste materials.

Payment shall be made based on the size and horizontal distance in linear feet of pipeline removed measured along the top centerline. At the Department's option, all abandoned pipe and appurtenances shall remain the property of the Department. If the Department opts not to remain owner of the removed facilities, then the Contractor shall remove and properly dispose of the facilities at his expense.

Payment shall be made under:

<u>Item No.</u>	<u>Description</u>	<u>Unit</u>
2500	Remove 3" and smaller diameter abandoned pipe	LF
2501	Remove 4" - 12" diameter abandoned pipe	LF
2502	Remove larger than 12" diameter abandoned pipe	LF

C2.60 Cutting and Plugging

The Contractor shall provide all labor, equipment and materials to cut and plug 16-inch and smaller pipe as designed on the plans or as directed by the Engineer. To cut and plug pipe shall include, but may not be limited to:

1. Excavating and maintaining the trench;
2. Performing a minimum of two complete cuts of the pipe to facilitate the plugging.
3. Removing of pipe or appurtenances to allow for the installation of plugs on 8" or less open ends of pipe;
4. Furnishing and installing grout to plug any abandoned open end(s) pipe;
5. Furnishing and installing cap(s) or plug(s) and restraints to adequately withstand a working pressure of 150 psi, on all in-service open end(s) of pipe;

City-wide Meter, Hydrant, and Valve Installation and Replacement
Contract 18-C-00030

6. Backfill and compacting the trench;
7. Cleaning up and restoring the job site which shall include re-grading the terrain; and
8. Removing and legally disposing of all waste materials.

Payment shall be made for each cut and plug accomplished and accepted by the Engineer.

Payment shall be made under:

<u>Item No.</u>	<u>Description</u>	<u>Unit</u>
2600	Cut and Plug 3in. and smaller pipe, to include meter service lines	EA
2601	Cut and Plug 4-, 6- and 8-in. Pipe	EA
2602	Cut and Plug 10-, 12-, and 16-in. Pipe	EA

C2.70 Pipeline Incidentals

Furnishing and installing 4-inch to 8-inch ductile iron pipe under tree root systems by hand excavating, mole excavation or “pushing”, as directed by the Engineer. This shall be considered complete compensation for pipe installation. **There will be no additional payment under the standard pipe installation pay item.**

1. Furnishing all labor equipment and materials to excavate the trench;
2. Maintaining the trench which shall include dewatering and sheeting and bracing as required by OSHA or as directed by the Engineer standards unless specifically provided for in a pay item;
3. Cleaning dirt and foreign material from within pipe and bell;
4. Furnishing and installing 4-inch to 8-inch ductile iron pipe;
5. Furnishing and installing EPDM push-on gaskets for all DIP;
6. Furnishing and installing blue polyethylene encasement on D.I Pipe & Fittings, per standard detail 2.05;
7. Backfilling and compacting the trench including re-grading the terrain;
8. Cleaning up and removing excess water main pipe and appurtenances;
9. Pressure testing the water main pipe;
10. Disinfecting the water main pipe;
11. Cleaning up and restoring the job site which shall include re-grading the terrain; and
12. Removing and legally disposing all waste materials.

Payment shall be made under:

<u>Item No.</u>	<u>Description</u>	<u>Unit</u>
2700	Furnish and push 4-in ductile iron pipe beneath/through root system	LF
2701	Furnish and push 6-in ductile iron pipe beneath/through root system	LF

2702 Furnish and push 8-in ductile iron pipe beneath/through root system LF

C2.80 Incidental Tapped Connections

The Contractor shall provide all labor, equipment and material to connect existing 3-inch and smaller water mains to the newly installed water mains (see Standard Detail 5.06). The incidental tapped connections shall include, but may not be limited to:

1. All necessary excavations;
2. Maintaining the excavation which shall include dewatering, bracing and sheeting where required or as directed by the Engineer;
3. Making a minimum of two cuts into the existing pipe to facilitate the connection to the existing pipe;
4. Making all necessary taps (2 may be required) that are required to affect the tie-in connection;
5. Furnishing and installing all necessary material, including reducers and increasers approved by the Water Department, which is/are required to construct the tie-in connections;
6. Furnishing and installing a 2-inch gate valve and box close the larger main;
7. Furnishing and installing 2-inch high density polyethylene (HDPE) tubing;
8. Furnishing and installing cap(s) or plug(s) and restraints adequate to withstand a working pressure of 150 psi, on all in-service open end(s) of pipe;
9. Backfill and compacting the trench;
10. Cleaning up and restoring the job site which shall include re-grading the terrain; and
11. Removing and legally disposing of all waste materials.

Payment shall be made for each 3-inch and smaller tapped connection furnished and installed into the piping system complete and working to the satisfaction of the Engineer. Payment for 2-inch gate valve and box will be made under the appropriate pay item number.

Payment shall be made under:

<u>Item No.</u>	<u>Description</u>	<u>Unit</u>
2800	Furnish and install 3" and smaller tapped connection (0-15' long)	EA
2801	Furnish and install 3" and smaller tapped connection (15' and longer)	EA

C3.00 Thrust Restraint

The Contractor shall provide for all labor, equipment and materials to completely furnish and/or install thrust restraint. The furnishing and installation of the thrust restraint shall include but not be limited to:

1. Excavating the trench;
2. Maintaining the trench that shall include dewatering and bracing and sheeting where required or as

City-wide Meter, Hydrant, and Valve Installation and Replacement
Contract 18-C-00030

directed by the Engineer;

3. Furnishing and installing approved wedge action restraint fitting or flange joint restraint;
4. Furnishing and installing manufactured restrained joints;
5. Furnishing of approved push-on restraint EPDM rubber gasket-type restraining devices (gaskets with stainless steel locking segments vulcanized into the rubber) on new push-on ductile iron pipe;
6. Furnishing and installing approved restraining devices on proposed PVC push-on joint pipe;
7. Furnishing and installing approved restraining devices on joints of existing pipe;
8. Backfill and compacting the trench;
9. Cleaning up and restoring the job site which shall include re-grading the terrain; and
10. Removing and legally disposing of all waste materials.

Payment for installation of manufactured restrained joints shall be for each bell and spigot joint assembled.

No additional compensation shall be made to the Contractor for field poured concrete in excess of the amount detailed in the Technical Specification or Standard Details without approval by the Engineer.

Payment will not be credited for restraining devices installed in conjunction with fire hydrant installations. Payment for installation of thrust restraints for fire hydrants (and for pipe on fire hydrant leads) shall be included in the price quoted for installation of fire hydrant assemblies.

Payment shall be made under:

<u>Item No.</u>	<u>Description</u>	<u>Unit</u>
3000	Furnish & install 4" wedge-action MJ or FL restraint	EA
3001	Furnish & install 6" wedge-action MJ or FL restraint	EA
3002	Furnish & install 8" wedge-action MJ or FL restraint	EA
3003	Furnish & install 10" wedge-action MJ or FL restraint	EA
3004	Furnish & install 12" wedge-action MJ or FL restraint	EA
3005	Furnish & install 14" wedge-action MJ or FL restraint	EA
3006	Furnish & install 16" wedge-action MJ or FL restraint	EA
3040	Furnish & install 4" bell or MJ restraint on existing pipe	EA
3041	Furnish & install 6" bell or MJ restraint on existing pipe	EA
3042	Furnish & install 8" bell or MJ restraint on existing pipe	EA
3043	Furnish & install 10" bell or MJ restraint on existing pipe	EA
3044	Furnish & install 12" bell or MJ restraint on existing pipe	EA
3045	Furnish & install 16" bell or MJ restraint on existing pipe	EA
3050	Furnish & install 4" wedge-action MJ restraint on new PVC pipe	EA
3051	Furnish & install 6" wedge-action MJ restraint on new PVC pipe	EA
3052	Furnish & install 8" wedge-action MJ restraint on new PVC pipe	EA

City-wide Meter, Hydrant, and Valve Installation and Replacement
Contract 18-C-00030

3053	Furnish & install 12" wedge-action MJ restraint on new PVC pipe	EA
3054	Furnish & install 16" wedge-action MJ restraint on new PVC pipe	EA
3070	Furnish 4-inch push-on-joint gasket-type (gripper) restraint	EA
3071	Furnish 6-inch push-on-joint gasket-type (gripper) restraint	EA
3072	Furnish 8-inch push-on-joint gasket-type (gripper) restraint	EA
3073	Furnish 12-inch push-on-joint gasket-type (gripper) restraint	EA
3074	Furnish 16-inch push-on-joint gasket-type (gripper) restraint	EA

C4.00 Fittings

The Contractor shall provide all labor and equipment to completely install plugs, caps, bends, sleeves, reducers, tees, crosses, and offsets. The installation of ductile iron fittings shall include, but not be limited to:

1. Excavating the trench;
2. Maintaining the trench which shall include dewatering and bracing and sheeting where required or as directed by the Engineer;
3. Furnishing and installing the appropriate fitting;
4. For HDPE pipe, furnishing and installing the appropriate HDPE mechanical joint adapters and back-up rings or mechanical joint glands, or SS inserts (if approved by the Engineer);
5. Backfill and compacting the trench;
6. Cleaning up and restoring the job site which shall include re-grading the terrain; and
7. Removing and legally disposing of all waste materials.

Additional compensation shall not be made for restraining devices used in conjunction with hydrant installations. Payment will be made for the number of each size and type of fittings installed and incorporated into the piping system complete, working, and operating to the satisfaction of the Engineer.

Payment shall be made under:

<u>Item No.</u>	<u>Description</u>	<u>Unit</u>
4000	Furnish and install 4" DI MJ plug or cap	EA
4001	Furnish and install 4" DI MJ bend, sleeve or reducer	EA
4002	Furnish and install 4" DI MJ tee	EA
4003	Furnish and install 4" (x 12") DI MJ offset	EA
4004	Furnish and install 6" DI MJ plug or cap	EA
4005	Furnish and install 6" DI MJ bend, sleeve or reducer	EA
4006	Furnish and install 6" DI MJ tee	EA
4007	Furnish and install 6" (x 12") DI MJ offset	EA
4008	Furnish and install 8" DI MJ plug or cap	EA
4009	Furnish and install 8" DI MJ bend, sleeve or reducer	EA

City-wide Meter, Hydrant, and Valve Installation and Replacement
Contract 18-C-00030

4010.1	Furnish and install 8" x 4" DI MJ tee	EA
4010.2	Furnish and install 8" x 6" DI MJ tee	EA
4010.3	Furnish and install 8" x 8" DI MJ tee	EA
4011	Furnish and install 8" (x 12") DI MJ offset	EA
4012	Furnish and install 12" DI MJ plug or cap	EA
4013	Furnish and install 12" DI MJ reducer	EA
4013.1	Furnish and install 12" DI MJ 11.25° (or 22.5°) bend or sleeve	EA
4013.2	Furnish and install 12" DI MJ 45° bend	EA
4013.3	Furnish and install 12" DI MJ 90° bend	EA
4014.1	Furnish and install 12" x 4" (or 6") DI MJ tee	EA
4014.2	Furnish and install 12" x 8" DI MJ tee	EA
4014.3	Furnish and install 12" x 12" DI MJ tee	EA
4015	Furnish and install 12" (x 12") DI MJ offset	EA
4016	Furnish and install 16" DI MJ plug or cap	EA
4017	Furnish and install 16" DI MJ reducer	EA
4017.1	Furnish and install 16" DI MJ 11.25° bend or sleeve	EA
4017.2	Furnish and install 16" DI MJ 22.5° bend	EA
4017.3	Furnish and install 16" DI MJ 45° bend	EA
4017.4	Furnish and install 16" DI MJ 90° bend	EA
4018.1	Furnish and install 16" x 4" (or 6") DI MJ tee	EA
4018.2	Furnish and install 16" x 8" DI MJ tee	EA
4018.3	Furnish and install 16" x 12" DI MJ tee	EA
4018.4	Furnish and install 16" x 16" DI MJ tee	EA
4019	Furnish and install 16" (x 12") DI MJ offset	EA

C5.00 Fire Hydrants

The Contractor shall provide all labor, equipment and specified materials to completely furnish and/or install full and complete fire hydrant assembly on existing water main, or relocate existing fire hydrant assembly, as shown on the construction plans or as directed by the Engineer.

As notified in Specific Provision S4.02, each fire hydrant installation (replacement, relocation, or new isolated installation) issued for construction **must be completed within 10 calendar days** of issuance to the Contractor.

The standard fire hydrant assembly (FHA) to be furnished includes up to 10 lf of 6-in. DIP, hydrant elbow, hydrant barrel extension, and hydrant barrel as shown in Standard Detail 4.01. The standard "full" hydrant assembly to be furnished further includes a hydrant valve and a tee or tapping sleeve. When agreed by the Engineer, a Gradelok offset fitting may be used to adjust hydrant elevation, and will be compensated for separately.

(Note that whenever a Gradelok fitting is used with a fire hydrant installation, the standard 3 ft. to 5 ft.

depth of bury required at the hydrant must be maintained.)

Hydrant assembly installation work order work shall include, but may not be limited to:

1. Excavation of hydrant assembly trench;
2. Maintaining the trench that shall include dewatering, bracing and sheeting where required or as directed by the Engineer;
3. As directed, installation either by:
 - a) cutting an existing hydrant tee out of an existing water main to remove and replace the tee, valve and hydrant assembly, or
 - b) removing existing hydrant assembly and/or valve for relocation or replacement, or
 - c) removing hydrant lead and hydrant assembly (downstream of existing hydrant valve) to facilitate hydrant relocation, or new valve and hydrant assembly installation
 - d) Tapping an existing main for a new fire hydrant installation;
4. Anchoring the hydrant to existing or new main;
5. Furnish and install up to and including ten (10) foot of 6-inch ductile iron pipe;
6. Remove any plugs, caps, restraining devices, etc. from existing water mains to facilitate the connection;
7. Furnish and install any and all mechanical thrust restraint required downstream of the hydrant valve in accordance with the Technical Specifications or as directed by the Engineer;
8. Furnish and install polyethylene encasement for all buried pipe and fittings;
9. Furnish and install hydrant in the plumb position, with 4.5 ft. clearance in the back and 7 ft. clearance in the front and on each side, from walls, poles and obstructions;
10. Furnish and install a concrete thrust collar around the barrel of the hydrant and 12 in. below grade as shown in Standard Detail 4.01;
11. Furnish and install a concrete "support block" under each hydrant;
12. Furnish and install a concrete support cradle under each hydrant tee on PVC mains;
13. Backfill and compact hydrant assembly trench;
14. Furnish high grade enamel OSHA yellow paint and paint hydrant barrel as required in the Technical Specifications;
15. Furnish high grade enamel OSHA green paint and paint the hydrant bonnet;
16. Furnish and install one blue, reflective pavement marker (RPM) in the street adjacent to the hydrant at a location to be determined by the Engineer. The RPM shall meet or exceed all provisions of the Florida Department of Transportation, Standard Specifications for Road and Bridge Construction, Section 706;
17. Furnish and install an approved blue VALVE curb marker on the adjacent curb (or edge of pavement if no curb is present, for each valve installed;
18. Pressure test the hydrant assembly in conformance with these documents;
19. Backfill and compact the trench;
20. Cleaning up and restoring the job site which shall include re-grading the terrain; and
19. Removing and legally disposing of all waste materials.

The Contractor shall do all things necessary to completely install a fire hydrant assembly in accordance

with the Technical Specifications, Standard Details or as directed by the Engineer.

Additional compensation will be provided for any Maintenance of Traffic (MOT) devices required to complete a given work order, via either:

- 1) the MOT sub-contractor's invoice for that work (corroborated by count records the Contractor shall provide to the Engineer daily), plus 10% OH&P; or
- 2) if installations are self-performed by the Contractor, by the applicable MOT contract pay items.

Restoration required shall be compensated in accordance with the restoration contract pay items.

In addition, it will be the Contractor's responsibility to determine the correct size (bury depth) of each hydrant installed so that the requirements of the Technical Specifications are satisfied. Any hydrant not installed to the proper grade shall be replaced with one of the correct size by the Contractor at his expense prior to final approval and acceptance

Fittings required because of contractor convenience, (i.e. installed because the contractor elected to install a shallow bury hydrant) shall be furnished and installed at the contractor's expense.

Payment will be based on the number of hydrant assemblies installed complete and working to the satisfaction of the Engineer. Payment for Tees, Valves, Taps, Fittings (except the hydrant elbow which is part of the hydrant assembly), and Restoration will be made utilizing the appropriate contract pay items. Separate payment will be made for any 6-inch ductile iron pipe in excess of 10-feet required to connect the hydrant gate valve to the hydrant.

Payment shall be made under:

<u>Item No.</u>	<u>Description (see C5.00, 3rd paragraph for definition of FHA & Full FHA)</u>	<u>Unit</u>
5000	F&I Full FHA on new or ex. main – via Tee or Tap <i>(valve and tee/tap paid separate)</i>	EA
5001	F&I Full FHA on ex. main – via Remove & Replace ex. hydrant, valve & tee <i>(new valve and tee paid separate)</i>	EA
5002	F&I FHA and Valve on ex. main – via Remove & Replace ex. hydrant and valve downstream of ex. tee <i>(new valve paid separate)</i>	EA
5003	F&I FHA and Valve on ex. main – via Remove & Replace ex. hydrant assembly downstream of ex. valve <i>(new valve paid separate)</i>	EA
5004	Remove and Relocate ex. FHA and/or valve downstream of ex. hydrant valve or tee	EA
5010	F&I 6" Gradelok fitting	EA

5011	F&I 12" Gradelok fitting	EA
5012	F&I 24" Gradelok fitting	EA

5.10 Fire Hydrants: Removal Only

The Contractor shall provide all labor, equipment, and material for work orders directing removal and salvage of existing fire hydrant assemblies from existing water mains. Hydrant removal and salvage includes, but may not be limited to:

1. Excavate the hydrant pit;

If Type I Removal - requires removal to existing hydrant valve (*existing valve to remain, wasted*):

2. Furnish and install restraining devices to anchor the existing hydrant shut-off valve to the pipeline tee;
3. Remove hydrant from hydrant lead (or, remove hydrant and lead);
4. Furnish & install restrained plug or cap, and/or thrust block (if required and agreed by the Engineer) behind the cap or plug; or,

If Type II Removal - removal includes the existing hydrant, hydrant valve and tee:

5. Furnish & install new spool-piece of appropriate diameter pipe, sleeve & restraints to restore the main line after Tee is removed;
6. Remove any hydrant protection post(s);
7. Backfill and compact the hydrant pit;
8. Clean up and restore the job site which shall include re-grading the terrain;
9. Remove and legally dispose of all waste materials;
10. Transport removed hydrant without delay to the location designated by the Engineer or legally dispose the hydrant; and
11. Unload the removed hydrant at the designated location.

Contractor shall be paid for each hydrant removed, salvaged, returned or disposed. All hydrants removed shall remain the property of the City unless otherwise directed by the Engineer. If the City opts not to remain the owner, the Contractor shall remove and properly dispose of the hydrant at his expense.

If Type I hydrant removal, costs of the fittings and thrust block (if required) shall be included in the unit price quoted for the removal pay item.

If Type II hydrant removal, the Contractor shall receive additional compensation for the new pipe spool-piece, solid sleeve, and restraint devices required to restore the mainline, in accordance with the applicable contract pay item unit prices.

City-wide Meter, Hydrant, and Valve Installation and Replacement
Contract 18-C-00030

Additional compensation will be provided for any Maintenance of Traffic (MOT) devices required to complete a given work order, via either:

- 1) the MOT sub-contractor's invoice for that work (corroborated by count records the Contractor shall provide to the Engineer daily), plus 10% OH&P; or
- 2) if installations are self-performed by the Contractor, by the applicable MOT contract pay items.

Restoration required shall be compensated in accordance with the restoration contract pay items.

Payment shall be made under:

<u>Item No.</u>	<u>Description</u>	<u>Unit</u>
5101	Remove and salvage hydrant – Type I removal	EA
5102	Remove and salvage hydrant – Type II removal	EA

C5.30 Protection Post

The Contractor shall provide all labor, equipment, and material for furnishing and installing protection posts as part of the hydrant, meter or fire line installation as shown on the plans or as directed by the Engineer. Hydrant protection post installation shall include, but may not be limited to, the following:

1. Excavation of protection post pit;
2. Furnishing and installing of 6-in. diameter ductile iron protection post in a plumb position with all of the hose nozzles clear of the posts;
3. Furnishing and installing the necessary concrete as called for in the Technical Specifications;
4. Furnishing OSHA yellow paint and painting protection post
5. Cleaning up and restoring the job site which shall include re-grading the terrain; and
6. Removing and legally disposing of all waste materials.

Payment shall be for each protection post that is installed and accepted by the Engineer.

Payment shall be made under:

<u>Item No.</u>	<u>Description</u>	<u>Unit</u>
5300	Furnish and install protection post	EA

C6.00 Valves – Concurrent with Other New Water Main Installations

City-wide Meter, Hydrant, and Valve Installation and Replacement
Contract 18-C-00030

Concurrent with “other” water construction performed by the Contractor for the City, the Contractor shall provide all labor, equipment and materials to completely furnish and install 2-inch through 16-inch gate valves, and 16-inch butterfly valves, including all accessories and incidentals. Valve installations described in this Section shall be to facilitate or provide operation/control for other (concurrent) water installations the Contractor is performing for the City - herein identified as WOW, for work performed “with other work”. Separate, isolated, standalone valve replacements or installations (those performed without other work) are covered in the next Section.

Valve installation “with other work” (WOW) shall include, but may not be limited to:

1. Excavating the trench;
2. Maintaining the trench that shall include dewatering and bracing and sheeting where required or as directed by the Engineer;
3. Furnish and installing a valve in a mainline with a valve box or a tapping valve on a tapping sleeve with a valve box;
4. Backfilling and compacting the trench;
5. Furnishing, forming and pouring a 6-inch thick concrete pad around each valve box installed in non-paved areas;
6. Furnishing paint and painting valve box cover;
7. Furnishing and installing or forming and pouring concrete support blocks under valves installed on PVC and HDPE pipeline;
8. Furnishing and installing valve curb markers and brass ID tags for each valve installed;
9. Furnish and install (or form and pour) concrete support blocks under valves installed on PVC and HDPE pipelines;
10. Cleaning up and restoring the job site which shall include re-grading the terrain; and
11. Removing and legally disposing of all waste materials.

Payment shall be made for the number of each size valve and valve box installed and incorporated into the piping system complete, working and operating to the satisfaction of the Engineer. Separate compensation shall be provided for MJ restraints, and any valve nut extension required, installed and accepted by the Engineer, per length of extension installed.

Payment shall be made under:

<u>Item No.</u>	<u>Description</u>	<u>Unit</u>
6000	F&I 2" gate valve (wow) and box on new main	EA
6001	F&I 4" gate or tapping valve (wow) and box on new main	EA
6002	F&I 6" gate or tapping valve (wow) and box on new main	EA
6003	F&I 8" gate or tapping valve (wow) and box on new main	EA
6004	F&I 10" gate or tapping valve (wow) and box on new main	EA
6005	F&I 12" gate or tapping valve (wow) and box on new main	EA

6006	F&I 16" gate or tapping valve (wow) and box on new main	EA
6020	F&I 16" butterfly valve (wow) and box on new main	EA
6080	F&I 2-ft. valve nut extension	EA
6081	F&I 3-ft. valve nut extension	EA
6082	F&I 4-ft. valve nut extension	EA

C6.10 Valves: Isolated Replacements/Installations on Existing Water Mains

The Contractor shall provide all labor, equipment and materials to completely furnish and install in-line valves into existing pipelines, including all accessories and incidentals, to include 2-in. thru 16-in. gate valves and 16-in. butterfly valves. Installations or replacements directed through these work orders will typically be to remove and/or replace existing broken valves, either buried or in below-grade vaults, or to install a single valve where one did not exist before, i.e., the work required will be isolated valve installations and will not include other adjacent water main construction.

Annually, the Department anticipates issuing work orders for 40 isolated 16-inches and smaller valve replacements/installations.

Valve installation/replacement work order work shall include, but may not be limited to:

1. Excavate the trench for installation and/or removal; or,
2. If existing valve located in vault, remove and dispose of the concrete lid/cover of a below-grade masonry vault, and remove top row of masonry blocks;
3. Maintain the trench or vault, that shall include dewatering and bracing and sheeting where required or as directed by the Engineer;
4. If valve replacement, remove and dispose of existing valve;
5. Furnish and install a specified valve into an existing mainline with a valve box, including making two cuts of the existing pipe to remove the broken valve or to install the new valve;
6. Furnish and install appropriate sized solid-sleeve, up to 4-ft. spool piece of pipe, and restraint devices necessary to install the valve or replacement, or (if not replacing a valve) to sleeve the pipe back together;
7. Polywrap all buried DIP and fittings installed;
8. Backfill and compact the trench, or the vault;
9. Furnish, form and pour a 6-in. thick concrete pad around each valve box installed in non-paved areas;
10. Furnish approved paint and paint the valve box cover;
11. Furnishing and installing valve curb markers and brass ID tags for each valve installed;
12. Furnish and install (or form and pour) concrete support blocks under valves installed on PVC and HDPE pipelines;
13. Clean-up and restore the job site which shall include re-grading the terrain; and
14. Remove and legally dispose of all waste materials.

City-wide Meter, Hydrant, and Valve Installation and Replacement
Contract 18-C-00030

Payment shall be made for the number of each size valve and valve box installed and incorporated into the piping system complete, working and operating to the satisfaction of the Engineer. No additional compensation will be provided for pipe spool-piece, solid-sleeve, or restraint devices necessary to install the valve into an existing pipeline – costs of these items should be prorated and included in the applicable valve installation pay item.

Additional compensation will be provided for any Maintenance of Traffic (MOT) devices required to complete a given work order, via either:

- 1) the MOT sub-contractor's invoice for that work (corroborated by count records the Contractor shall provide to the Engineer daily), plus 10% OH&P; or
- 2) if installations are self-performed by the Contractor, by the applicable MOT contract pay items.

Additional compensation shall be provided for restoration required, in accordance with the contract restoration pay items.

The Contractor shall be compensated for any linestops required (and agreed by the Engineer) to facilitate shutdown for the Valve Installation/Replacements in accordance with the applicable linestop contract pay items.

Payment shall be made under:

<u>Item No.</u>	<u>Description</u>	<u>Unit</u>
6100	F&I 2" gate valve and box on ex. main	EA
6101	F&I 3" gate valve and box on ex. main	EA
6102	F&I 4" gate valve and box on ex. main	EA
6103	F&I 6" gate valve and box on ex. main	EA
6104	F&I 8" gate valve and box on ex. main	EA
6105	F&I 10" gate valve and box on ex. main	EA
6106	F&I 12" gate valve and box on ex. main	EA
6107	F&I 16" gate valve and box on ex. main	EA
6115	F&I 16" butterfly valve and box on ex. main	EA
6130	F&I 16" gate valve and box on ex. DIP or CIP, in ex. Vault	EA
6131	F&I 16" butterfly valve and box on ex. DIP or CIP, in ex. Vault	EA
6140	Remove ≥16" valve from ex. vault, sleeve pipe ends together & backfill vault	EA

C6.20 **Line Stops**

The Contractor shall furnish all labor, equipment, tools and materials to install line stops on existing water

mains.

The line stop installation shall include but is not limited to:

1. Excavating the trench;
2. Maintaining the trench that shall include dewatering and bracing and sheeting where required or as directed by the Engineer;
3. Furnishing and installing the line stop;
4. Furnishing and installing polywrap on line stop appurtenances remaining on the pipe after the line stop is removed;
5. Furnishing and installing reverse dead-man restraint with split wedge action restraints as shown in Standard Detail 2.12A, as applicable, or pouring concrete encasement around the sleeve as directed by the Engineer;
6. Compacting soil in trench around dead-man and line stop to a minimum 98% modified proctor density;
7. Excavating the trench to remove line stop;
8. Backfilling and compacting the trench;
9. Cleaning up and restoring the job site which shall include re-grading the terrain; and
10. Removing and legally disposing of all waste materials.

Payment shall be made under:

<u>Item No.</u>	<u>Description</u>	<u>Unit</u>
6200	F&I 2" or 2-1/2" Line Stop on Existing Water Main	EA
6201	F&I 4" Line Stop on DI/CI/PVC Water Main	EA
6202	F&I 4" Line Stop on AC Water Main	EA
6203	F&I 6" Line Stop on DI/CI/PVC Water Main	EA
6204	F&I 6" Line Stop on AC Water Main	EA
6205	F&I 8" Line Stop on DI/CI/PVC Water Main	EA
6206	F&I 8" Line Stop on AC Water Main	EA
6207	F&I 10" Line Stop on DI/CI/PVC Water Main	EA
6208	F&I 12" Line Stop on DI/CI/PVC Water Main	EA
6209	F&I 16" Line Stop on DI/CI/PVC Water Main	EA

Thrust restraint required for linestop installation shall be paid for under the appropriate contract pay items, i.e., split wedge-action restraints and forming, placing, and pouring reinforced concrete for deadmen, or forming, placing, and pouring reinforced concrete for concrete encasement. Restoration for linestop installations shall be paid for under the appropriate restoration contract pay item.

C6.30 Insertion Valves

City-wide Meter, Hydrant, and Valve Installation and Replacement
Contract 18-C-00030

The Contractor shall furnish all labor, equipment, tools and materials to install TEAM insertion valves on existing water mains that are under pressure

Insertion valve installation shall include but is not limited to:

1. Excavating the trench;
2. Maintaining the trench that shall include dewater and bracing and sheeting where required or as directed by the Engineer;
4. Cleaning the pipe;
5. Furnishing and installing the appropriate insertion valve;
6. Furnishing and installing polywrap on valve and pipe;
7. Backfilling and compacting the trench;
8. Cleaning up and restoring the job site which shall include re-grading the terrain; and
9. Removing and legally disposing of all waste materials.

Payment shall be made under:

<u>Item No.</u>	<u>Description</u>	<u>Unit</u>
6304	F&I 4" TEAM insertion valve on Existing Water Main	EA
6306	F&I 6" TEAM insertion valve on Existing Water Main	EA
6308	F&I 8" TEAM insertion valve on Existing Water Main	EA
6312	F&I 12" TEAM insertion valve on Existing Water Main	EA

Restoration will be paid for under the appropriate restoration pay item.

C7.00 Taps

The Contractor shall provide all labor and equipment for installing tapping sleeves and making the appropriate **full port** tap complete and operable. The tapping sleeve installation shall include:

1. Excavating the trench;
2. Maintaining the trench that shall include dewatering and bracing and sheeting where required or as directed by the Engineer;
3. Furnishing and installing the tapping sleeve;
4. Pressure testing the tapping sleeve and valve;
5. Making the full port tap, up to and including 36-inch;
6. Furnishing and installing mechanical joint tapping sleeves for size on size pipe taps or as directed by the engineer;
7. Furnishing, installing and sealing the tapping sleeve with blue polyethylene encasement of not less than 8 mils thick;
8. Backfilling and compacting the trench;

City-wide Meter, Hydrant, and Valve Installation and Replacement
Contract 18-C-00030

9. Cleaning up and restoring the job site which shall include re-grading the terrain; and
10. Removing and legally disposing of all waste materials.

Payment shall be based on the number and size of tapping sleeves installed and incorporated into the piping system complete, working and operating to the satisfaction of the Engineer. Valves and valve boxes shall be paid for by the appropriate pay item.

Payment shall be made under:

<u>Item No.</u>	<u>Description</u>	<u>Unit</u>
7001.0	F&I 4" x 4" MJ tapping sleeve and make tap	EA
7001.1	F&I 6" x 4" Steel tapping sleeve and make tap	EA
7001.2	F&I 6" x 6" MJ tapping sleeve and make tap	EA
7002.1	F&I 8" x 4" Steel tapping sleeve and make tap	EA
7002.2	F&I 8" x 6" Steel tapping sleeve and make tap	EA
7002.3	F&I 8" x 8" MJ tapping sleeve and make tap	EA
7003.1	F&I 12" x 4" Steel tapping sleeve and make tap	EA
7003.2	F&I 12" x 6" Steel tapping sleeve and make tap	EA
7003.3	F&I 12" x 8" Steel tapping sleeve and make tap	EA
7003.4	F&I 12" x 12" MJ tapping sleeve and make tap	EA
7004.1	F&I 16" x (\leq 8") MJ tapping sleeve and make tap	EA
7004.2	F&I 16" x 12" Steel tapping sleeve and make tap	EA
7004.3	F&I 16" x 16" MJ tapping sleeve and make tap	EA

C8.00 Water Meter and Fire Line Service Installation

C8.10 Metered Services (Two-Inch and Less) with Pipe Work

The Contractor shall provide all labor, materials and equipment for the installation and/or transfer of 3/4" (single or dual service), 1", 1½", and 2" meters, and 2" double detector check valves, as specified.

New meter service installations and/or transfers issued to the Contractor through work orders will be independent of pipeline construction projects – typically issued in response to customer applications for water service. Most will be isolated single installations, in varied locations across the City of Tampa water service area, which extends from South Tampa to New Tampa, from 50th Street to Memorial Highway.

The Department expects 1,000 new meter service installations will be required annually - typically half each of long-side and short-side services. If 3 contracts are awarded, each contract awarded should expect approximately 330 meter service installations will be required. However, the number of meter installation work orders issued to a Contractor will depend on performance and timeliness of

completion on previous meter installation work orders issued to that Contractor, to include satisfactory restoration.

As notified in Specific Provision S4.02, each new meter service installation issued through a work order **must be completed within fourteen (14) calendar days** of issuance to the Contractor.

Based on Department performance expectations from the Mayor, meter installations must be completed within 2 weeks of work order issuance **at least 98% of the time**.

Given the time constraints for these installations, the Contractor should expect some nighttime and/or weekend work will be required to complete meter installations issued through work orders – and that should be factored into unit prices quoted for these installations. Additional compensation for working non-standard hours or days will not be provided for meter service installation work orders. Unit prices quoted shall include all costs required to complete the services requested, as specified.

Meter service lengths (as described in the pay items) are defined as follows:

- 0-15' service line required from main to meter is up to 15' long
- +15-80' service line required is greater than 15', up to and including 80'
- +80-150' service line required is greater than 80', up to and including 150'

All water meters and double detector check valve assemblies will be furnished by the City, for installation by the Contractor.

Meter service installation shall include, but may not be limited to:

1. Excavating and maintaining the trench;
2. Making the appropriate size tap;
3. When directed by the Engineer or as indicated in the standard details, furnish and install an appropriately sized steel, PVC or HDPE sleeve under paved areas for long-side meter service by open cut, horizontal directional drilling/directional bore or "moling", as directed by the Engineer or as indicated in the standard details. If steel is provided for sleeves it shall be SCH 40 pipe, PVC shall be SCH 80 solvent weld pipe, HDPE pipe shall be as specified elsewhere in the Contract per pipe size, i.e., 2" HDPE shall meet the HDPE tubing specification, 4" and above HDPE shall meet the HDPE pipe specification;
4. For use on DIP, CIP or PVC pipe, furnish and install the appropriate size and type of corporation stop, HDPE tubing, PVC pipe, any required service fittings, curb stop, meter box and lid, and tail piece extension as designated by the Department's Technical Specifications and Standard Details For use on HDPE pipe, furnish and install the appropriate size and type of electrofusion tapping tee or electrofusion corporation, HDPE tubing or pipe, any required service fittings, curb stop, meter box and lid, and tail piece extension as designated by the Department's Technical Specifications and Standard Details;
5. For all long-side HDPE service lines, furnish and install two continuous 12-gauge wires along the

City-wide Meter, Hydrant, and Valve Installation and Replacement
Contract 18-C-00030

top of the pipe, inside the sleeve. If a steel casing sleeve is used, tracer wire shall be taped every 12-inches to the top outside of the sleeve. There shall be no dead ends and each locator wire shall be routed from the corporation to the meter box. Connections between wire ends shall be made using approved connections at each end as shown in the standard details;

6. Installation of the appropriate sized (City furnished) meter, or transferring an existing meter to the new service line;
7. Relocating existing meters and/or adjusting existing meter boxes to grade;
8. Backfilling and compacting of all excavations;
9. Clean-up and return the job site to its original condition which includes but is not limited to restoring the elevation of surface to its original grade;
10. Removing and legally disposing of all waste materials.

Payment shall be made for each meter service furnished and installed, and accepted by the Engineer.

Additional compensation will be provided for any Maintenance of Traffic (MOT) devices required to complete a given work order, via either:

- 1) the MOT sub-contractor's invoice for that work (corroborated by count records the Contractor shall provide to the Engineer daily), plus 10% OH&P; or
- 2) if installations are self-performed by the Contractor, by the applicable MOT contract pay items.

Additional compensation shall be provided for restoration in accordance with the contract restoration pay items.

Payment shall be made under:

<u>Item No.</u>	<u>Description for Services on PVC, DIP, OR CIP</u>	<u>Unit</u>
8100	Furnish, tap, & install 3/4" or 1" meter service (0-15')	EA
8101	Furnish, tap, & install 3/4" meter service (+15-80')	EA
8102	Furnish, tap, & install 3/4" meter service (+80-150')	EA
8103	Furnish, tap, & install 3/4" or 1" Dual meter service (0-15')	EA
8104	Furnish, tap, & install 3/4" Dual or 1" Dual meter service (+15-80')	EA
8105	Furnish, tap, & install 3/4" Dual meter service (+80-150')	EA
8106	Furnish, tap, & install 1" Dual meter service (+80-150')	EA
8107	Furnish, tap, & install 1" or 1-1/2" meter service (+15-80')	EA
8108	Furnish, tap, & install 1" or 1-1/2" meter service (+80-150')	EA
8109	Furnish, tap, & install 1 1/2" or 2" meter service (0-15')	EA
8110	Furnish, tap, & install 2" DDCV & service (0-15')	EA

City-wide Meter, Hydrant, and Valve Installation and Replacement
Contract 18-C-00030

<u>Item No.</u>	<u>Description for Services on HDPE Pipe</u>	<u>Unit</u>
8120	Furnish, tap, & install 3/4" or 1" meter service (0-15')	EA
8121	Furnish, tap, & install 3/4" meter service (+15-80')	EA
8122	Furnish, tap, & install 3/4" meter service (+80-150')	EA
8123	Furnish, tap, & install 3/4" Dual meter service (0-15')	EA
8124	Furnish, tap, & install 3/4" Dual or 1" Dual meter service (+15-80')	EA
8125	Furnish, tap, & install 3/4" Dual meter service (+80-150')	EA
8126	Furnish, tap, & install 1" Dual meter service (0-15')	EA
8127	Furnish, tap, & install 1" or 1-1/2" meter service (+15-80')	EA
8128	Furnish, tap, & install 1" or 1-1/2" meter service (+80-150')	EA
8129	Furnish, tap, & install 1 1/2" or 2" meter service (0-15')	EA
8130	Furnish, tap, & install 2" DDCV & service (0-15')	EA

C8.20 ~~deleted~~

C8.30 **Service Installations 3-inch and Larger**

The Contractor shall provide for all the labor, equipment and materials for installing 3-inch and larger meters and/or installing double detector check valve assemblies (DDCVA) into a large service. The large service installation may be located in an above-ground vault, a below-ground vault, or may be an above-ground installation in accordance with the construction plans or as directed by the Engineer. The large service installation shall include, but is not limited to:

1. Obtaining from the Tampa Water Department, 26th Avenue Warehouse, a large meter assembly and/or double detector check valve assembly as directed by the Engineer or as shown the plans;
2. Installing a City-furnished double detector check valve assembly including the detector check bypass metered assembly;
3. Excavating and maintaining the trench;
4. Installing the furnished, large meter including furnishing and installing a 2-inch meter by-pass assembly and the-furnished by-pass meter; and
5. Furnishing and installing bolts, nuts, gaskets and all appurtenances necessary to install either the large meter or double detector check valve assembly;
- 6 Backfilling and compacting the trench;
- 7 Cleaning up and restoring the job site which shall include re-grading the terrain; and
8. Removing and legally disposing of all waste materials.

The Department shall provide the appropriate size meter and by-pass meter for all large meter services or appropriate size double detector check valve assembly. The Contractor shall furnish and install all bolts, nuts, gaskets, by-pass piping (large meter only) and appurtenances necessary to install a large meter or double detector check valve assembly.

City-wide Meter, Hydrant, and Valve Installation and Replacement
Contract 18-C-00030

Payment will be made for each large meter service installed or double detector check valve assembly installed, and accepted by the Engineer.

Additional compensation will be provided for any Maintenance of Traffic (MOT) devices required to complete a given work order, via either:

- 3) the MOT sub-contractor's invoice for that work (corroborated by count records the Contractor shall provide to the Engineer daily), plus 10% OH&P; or
- 4) if installations are self-performed by the Contractor, by the applicable MOT contract pay items.

Additional compensation shall be provided for restoration required, in accordance with the contract restoration pay items.

Payment shall be made under:

<u>Item No.</u>	<u>Description</u>	<u>Unit</u>
8300	Install city-provided 3" meter (slab or vault to be paid separate)	EA
8301	Install city-provided 4" meter (slab or vault to be paid separate)	EA
8302	Install city-provided 6" meter (slab or vault to be paid separate)	EA
8303	Install city-provided 8" meter (slab or vault to be paid separate)	EA
8320	Install 4" double detector check valve assembly	EA
8321	Install 6" double detector check valve assembly	EA
8322	Install 8" double detector check valve assembly	EA
8323	Install 10" double detector check valve assembly	EA
8324	Install 12" double detector check valve assembly	EA

C8.40 Vaults and Auxiliary Above-Ground Installation Materials

The Contractor shall provide for all labor, equipment, and materials for furnishing and installing an above-ground vault or below-ground vault and all auxiliary materials for an above-ground large service.

The vault and auxiliary materials shall include, but may not be limited to:

1. Excavating the trench;
2. Maintaining the excavations that shall include dewatering, sheeting and bracing where required or as directed by the Engineer;
3. Furnishing, installing, and constructing an above-ground vault per Standard Details 6.09 and 6.10 or below-ground vault incorporating one or more large service installation within the construction, per Standard Details 6.04 – 6.08;

City-wide Meter, Hydrant, and Valve Installation and Replacement
Contract 18-C-00030

4. Furnishing and installing a 6-inch concrete slab, reinforcing steel and pipe supports incorporating one or more free-standing above-ground large services within the construction, per Standard Details 6.01 - 6.03;
5. Backfilling and compacting the excavation;
6. Furnishing paint and painting the above-ground large service installation and;
7. Sealing top of vault to sides of vault with an approved material;
8. Cleaning up and restoring the job site which shall include re-grading the terrain; and
9. Removing and legally disposing of all waste materials.

The Contractor shall furnish and install the appropriate size pre-cast traffic bearing vault top and bottom slabs to construct a large service vault. If the Engineer determines that either part or all of any vault or other structure requires pouring concrete in-place (including reinforcing steel), then the Contractor shall pour a slab at no additional cost to the City.

The Contractor shall furnish all other material to complete construction of a large service vault.

Vaults shall be of various sizes. Payment shall be made for each vault installed and accepted by the Engineer.

Each above-ground assembly installed and accepted by the Engineer will be paid at the applicable line item. The pay item for furnishing and installing auxiliary materials shall include but not necessarily be limited to painting all above-ground facilities, furnishing and installing all required flanged bolt sets, furnishing and installing pipe supports for large meters and/or DDCVs and furnishing and installing the concrete pad as shown in the details.

Payment shall be made under:

<u>Item No.</u>	<u>Description</u>	<u>Unit</u>
8400	Furnish and install 6' 0" x 6' 0" above-ground vault or below-ground vault	EA
8401	Furnish and install 8' 0" x 5' 4" above-ground vault or below-ground vault	EA
8402	Furnish and install 9' 4" x 8' 0" above-ground vault or below-ground vault	EA
8403	Furnish and install 10' 8" x 8' 0" above-ground vault or below-ground vault	EA
8404	Furnish and install auxiliary materials for above-ground large service w/ 12' x 5' concrete slab	EA
8405	Furnish and install auxiliary materials for above-ground large service w/ 12' x 9' concrete slab	EA

C9.00 Restoration and Miscellaneous Incidental Items

C9.10 General

Two classes of restoration services will be required through this Contract: Roadway and Roadside. These services will further break down into 1) restoration work required incidental to Work Order Work performed by the Contractor, or 2) restoration work performed in response to a City-issued Restoration Work Order, to restore of areas (roadway or roadside) disturbed by other contractor(s) (others) performing water construction work for the City.

Because Contractor expenses (and requirements) to perform restoration for others are different than those for Contractor self-performed restoration, separate pay items are included herein for each – pay items compensating for restoration completed for self (RFS), and pay items compensating for restoration completed for others (RFO). RFO restoration services will require mobilization to a location specifically to perform restoration within a specified time period; RFS restoration services will be performed at a location the Contractor has already mobilized to for other Work Order Work. Contractor unit prices provided for each set of pay items shall include all expenses anticipated to complete the described task, as specified.

The Contractor shall furnish all labor, equipment, and materials to restore construction areas (to include streets, curbs, sidewalks, and driveways) to an equal or better condition than surfaces adjacent to the disturbed areas, and in conformance with the appropriate agency having jurisdiction over the restored area. Restoration services provided shall be in accordance Contract Document’s Technical Specifications Section T4.00 RESTORATION.

The Contractor shall restore areas to those limits as directed in the work order or by the Engineer, and shall be compensated in conformance with the appropriate restoration contract pay items, for actual quantities furnished and installed or measured.

As stated herein, upon final payment by the Department, the Contractor shall maintain the surface of the unpaved trenches, shrubbery, trees, fences, sod, and other surfaces disturbed for a period of 6 months thereafter, and shall maintain the repaved areas, curbs, gutters, and sidewalks, if replaced by the Contractor, for one year after final acceptance of the respective item. The cost of maintaining the restored areas shall be incidental to the cost of restoring the areas disturbed by the Contractor. These costs shall be prorated and included in the cost for the respective contract pay item.

Restoration Work Orders:

Restoration only work orders will generally be issued in response to water main construction done by others.

As notified in Specific Provision S4.02, restoration work orders issued must be completed within specified periods as follows, subsequent to issuance of the work order to the Contractor:

Restoration - State roads	1 day
Restoration - Streets, non-State roads	7 days

City-wide Meter, Hydrant, and Valve Installation and Replacement
Contract 18-C-00030

Restoration - Driveways	8 days
Restoration - Sidewalks	10 days

The Contractor should factor potential costs of meeting these time requirements into unit prices quoted for Restoration Work Order services. Additional compensation for working non-standard hours or days will not be provided. Unit prices quoted shall include all costs required to complete the services requested, as specified.

C9.20 Pavement - Roadway

The Contractor shall provide all labor, equipment and materials to remove and restore pavement and pavement bases that were cut and removed during the course of construction. Pavement and pavement base restoration shall include roadways, driveways, parking lots, etc. Under this section, payment shall be made for:

1. Furnishing, placing, grading, and compacting approved lime rock base course;
2. Furnishing, placing, grading, and compacting approved crushed concrete base course;
3. Furnishing, placing, grading, and compacting approved asphaltic base course, Superpave Type B-12.5;
4. Furnish and placing approved flowable fill;
5. Furnishing, placing, grading and compacting approved Superpave Type SP-12.5 or Type S-1 asphalt concrete - Surface Course;
6. Furnishing, placing, grading and compacting approved Superpave Type SP-12.5 or Type S-1 asphaltic concrete pavement – Full Depth;
7. Restoring 6" thick concrete driveway;
8. Furnishing and installing brick pavement;
9. Installing brick pavement;
10. Furnishing and installing Thermoplastic Striping;
11. Furnishing, placing, grading and compacting Superpave Type SP-9.5 or Type S-3 asphaltic concrete Overlay;
12. Mechanical milling of 1-inch of existing asphalt including proper disposal of the milled material;
13. Mobilization required for mechanical milling operations;
14. Furnishing and installing traffic loops as specified and directed by the Engineer;
15. Furnishing and installing signalization loops as specified and directed by the Engineer;
16. Furnishing Traffic Control Officer (Off-Duty Law Enforcement);
17. Furnishing and installing work zone signs;
18. Furnishing and installing traffic control devices to right-of-way permit requirements;
19. Removing, transporting and disposing of pavement, concrete curb, asphaltic curb and other items removed during construction;
20. Cleaning up and restoring the job site which shall include re-grading the terrain; and
21. Removing and legally disposing of all waste materials;
22. Prepare and provide site specific traffic control plans that have been signed-and-sealed by a licensed Florida Professional Engineer when required for MOT, in accordance with the applicable ROW-owning agency's requirements.

All surface restoration shall be as directed by the Engineer or the regulatory agency having jurisdiction over the roadway. All areas requiring pavement restoration shall be saw cut prior to construction pavement removal. The costs to mechanically saw cut pavement joints are considered incidental to pavement restoration and should be included in the cost.

City-wide Meter, Hydrant, and Valve Installation and Replacement
Contract 18-C-00030

Asphalt shall be measured for payment based the number of SY-IN of asphalt furnished and installed. Pavement, concrete curb, asphaltic concrete curb or other items removed during the course of pipeline construction shall be disposed of by the Contractor in a manner satisfactory to the Department. The cost of removal and disposal associated with all items shall be included in the assigned restoration item.

When required and authorized by the City based on project conditions, flowable fill may be utilized for bedding and backfilling utility trenches and paving subbase as an alternative to installing compacted granular fill. Flowable fill mix and installation shall conform to FDOT Standard Specifications for Road and Bridge Construction (2014), Section 121-1 through 121-6. Mix design must be approved by the City prior to jobsite delivery.

City street pavement shall be in accordance with of Tampa's PAVEMENT/RIGHT OF WAY RESTORATION REQUIREMENTS – REV-2009 guidelines - see contract Technical Specification Section T4.07.

Bricks shall be replaced in accordance with the of Tampa's Vitrified Brick Replacement (Revised 4/27/2009) guidelines. See Technical Specification Section T4.07, 6.0 Brick Replacement.

Mobilization shall only be paid for milling operations and shall only be paid once per job site unless otherwise approved in advance by the Engineer. Milling shall be made in thickness increments of one inch and shall include proper disposal of the milled material.

The Contractor shall furnish all labor, materials and equipment, necessary to replace and maintain complete traffic signalization loops as specified and directed by the Engineer. The work includes all saw-cutting of pavement, placement of loop wires and lead-in cables, non-metallic wire hold downs, wire identification tags and sealants, splicing and termination strips, testing and all other work incidental to the installation of a signalization loop complete in place. All signalization loops shall conform to the requirements of the latest edition of the Florida Department of Transportation Standard Specifications for Road and Bridge Construction. Payment for traffic signalization loops will be made at the appropriate contract item unit price per signalization loop installed.

The Contractor shall be compensated for any thermoplastic striping required based on the striping sub-contractor's invoice for work done for a given work order, plus 10% OH&P, or by the applicable contract pay items.

The Contractor shall be compensated for any maintenance of traffic required for a given work order based on the Maintenance of Traffic (MOT) installations required for a given work order, based on the MOT sub-contractor's invoice for a given work order (corroborated by count records the Contractor shall provide to the Engineer daily) plus 10% OH&P, or by the applicable contract pay items if installations are self-performed by the Contractor.

When and if required for maintenance of traffic, the Contractor shall be compensated for signed-and-

City-wide Meter, Hydrant, and Valve Installation and Replacement
Contract 18-C-00030

sealed MOT traffic control plans on a per plan sheet (SH) basis.

Asphalt restoration quantities shall be paid per square-yard per inch.

Payment shall be made under:

<u>Item No.</u>	<u>Description (RFS = restoration for self; RFO – restoration for others)</u>	<u>Unit</u>
9200	(RFS) Furnish, place, and compact lime rock base	CY
9201	(RFS) Furnish, place, and compact crushed concrete base	CY
9202	(RFS) Furnish and place approved flowable fill	CY
9203	(RFS) Furnish, place, and compact Superpave Type B-12.5 asphalt base course	SY-IN
9204	(RFS) Furnish and install asphalt concrete surface Type S-1	SY-IN
9205	(RFS) Furnish and install asphalt concrete surface Superpave Type SP-12.5	SY-IN
9206	(RFS) Furnish, place and grade Type S-III asphaltic concrete overlay	SY-IN
9207	(RFS) Furnish, place and grade Superpave Type SP-9.5 asphaltic concrete overlay	SY-IN
9208	(RFS) Mobilization to perform milling operations	EA
9209	(RFS) Mechanical milling of asphalt roadways in 1-inch increments	SY-IN
9210	(RFS) Furnish and install 6" thick concrete driveway	SY
9211	(RFS) Furnish and install brick pavement	SY
9212	(RFS) Install brick pavement furnished by City, Contractor F&I base	SY
9220	(RFO) Furnish, place, and compact lime rock base	CY
9221	(RFO) Furnish, place, and compact crushed concrete base	CY
9222	(RFO) Furnish and place approved flowable fill	CY
9223	(RFO) Furnish, place, and compact Superpave Type B-12.5 asphalt base course	SY-IN
9224	(RFO) Furnish and install asphalt concrete surface Type S-1	SY-IN
9225	(RFO) Furnish and install asphalt concrete surface Superpave Type SP-12.5	SY-IN
9226	(RFO) Furnish, place and grade Type S-III asphaltic concrete overlay	SY-IN
9227	(RFO) Furnish, place and grade Superpave Type SP-9.5 asphaltic concrete overlay	SY-IN
9228	(RFO) Mobilization to perform milling operations	EA
9229	(RFO) Mechanical milling of asphalt roadways in 1-inch increments	SY-IN
9230	(RFO) Furnish and install 6" thick concrete driveway	SY
9231	(RFO) Furnish and install brick pavement	SY
9232	(RFO) Install brick pavement furnished by City, Contractor F&I base	SY
9250	Furnish and install signalization loops	EA
9251	Furnish Traffic Control Officer (Off-Duty Law Enforcement)	MH
9252	Furnish and install Work Zone Signs	ED
9253	Furnish and install Business Signs	ED
9254	Furnish and install Barricades (Temporary – Type II)	ED
9255	Furnish and install Barricades (Temporary Type III) (6")	ED

9256	Furnish and install Advance Warning Arrow Panel	ED
9257	Furnish and install High Intensity Flashing Lights (Temporary-Type B)	ED
9258	Furnish and install Variable Message Sign (Temporary)	ED
9259	Prepare and submit agency specific S&S MOT plans, if required	SH

C9.30 Roadside Restoration

The Contractor shall provide for all labor, equipment and materials to restore the roadside areas disturbed during the course of the pipeline construction. Under this section, payment shall be made for:

1. Restoring typical concrete curb and gutter including stabilization of sub-base and installation of curb pads;
2. Restoring stone or pre-cast curb;
3. Furnishing and placing asphaltic concrete curb;
4. Remove and restoring 4-inch thick concrete sidewalk, including applicable sidewalk ramps;
5. Restoring concrete hexagon block sidewalk;
6. Restoring the roadside areas with approved sod. Restoring the roadside area and ditch bottoms and sides with sod shall include furnishing, grading, and placing the sod; and
7. Restoring the roadside areas with approved sprig and seed. Restoring the roadside area with sprig and seed shall include furnishing, grading, placing, fertilizing, mulching, sprigging and seeding.
8. Furnishing and installing detectable warning walking surfaces as directed by Engineer. The detectable warning surface will conform to the Florida Department of Transportation Standard Specifications for Road and Bridge Construction, current edition. The detectable warnings shall be installed in conformance with FDOT Standard Indexes 304 and 310 or in conformance with the requirements of the right-of-way regulatory agency with responsibility of the affected right-of-way. (Payment for curb and sidewalk associated with pedestrian access ramps will be made under the appropriate sidewalk and curb pay items.)
9. Cleaning up and restoring the job site which shall include re-grading the terrain; and
10. Removing and legally disposing of all waste materials.

Sidewalk and curb replacement pay quantities shall have maximum limits as specified in these documents, as shown in the plans or as directed by the Engineer. All linear foot units shall be measured along the curb line. In all cases, the sod or seed placed is to conform in kind to the existing at the particular location.

Permanent fence agreed to be removed or disturbed for water or stormwater main construction shall be replaced in-kind, to match existing, subsequent to construction. Fence restoration shall be coordinated with the property owner and the City, and shall be to the satisfaction of the Engineer. Compensation for permanent fence restoration shall be based on the fencing sub-contractor's invoice plus 15% OH&P; or if restoration is executed by Contractor, in accordance with Specific Provision 4.05.

Payment shall be made under:

City-wide Meter, Hydrant, and Valve Installation and Replacement
Contract 18-C-00030

<u>Item No.</u>	<u>Description (RFS = restoration for self; RFO – restoration for others)</u>	<u>Unit</u>
9300	(RFS) Furnish and install Type “D” concrete curb	LF
9301	(RFS) Furnish and install valley curb	LF
9302	(RFS) Furnish and install Miami curb	LF
9303	(RFS) Furnish and install Type “F” concrete curb	LF
9304	(RFS) Furnish and install stone or precast curb	LF
9305	(RFS) Remove and install existing stone curb	LF
9306	(RFS) Furnish and install asphaltic concrete curb	LF
9307	(RFS) Furnish and install 4" thick concrete sidewalk	SY
9308	(RFS) Furnish and install hexagon block sidewalk	SY
9309	(RFS) Grade and sod roadside, ditch bottoms and sides - Bahia	SY
9310	(RFS) Grade and sod roadside, ditch bottoms and sides – St. Augustine	SY
9311	(RFS) Grade, fertilize, sprig, and hydro-seed roadside	SY
9312	(RFS) Furnish and install detectable warnings sidewalk disability ramps	EA
9320	(RFO) Furnish and install Type “D” concrete curb	LF
9321	(RFO) Furnish and install valley curb	LF
9322	(RFO) Furnish and install Miami curb	LF
9323	(RFO) Furnish and install Type “F” concrete curb	LF
9324	(RFO) Furnish and install stone or precast curb	LF
9325	(RFO) Remove and install existing stone curb	LF
9326	(RFO) Furnish and install asphaltic concrete curb	LF
9327	(RFO) Furnish and install 4" thick concrete sidewalk	SY
9328	(RFO) Furnish and install hexagon block sidewalk	SY
9329	(RFO) Grade and sod roadside, ditch bottoms and sides - Bahia	SY
9330	(RFO) Grade and sod roadside, ditch bottoms and sides – St. Augustine	SY
9331	(RFO) Grade, fertilize, sprig, and hydro-seed roadside	SY
9332	(RFO) Furnish and install detectable warnings sidewalk disability ramps	EA

C9.40 Grouting Abandoned Pipe

The Contractor shall provide all labor and material necessary to grout abandoned pipes in place including but not limited to taps, caps, plugs, pipes, valves and fittings necessary to complete the work in a manner acceptable to the Engineer. Under this section, payment shall be made for:

1. Excavating the trench;
2. Maintain the trench;
3. Furnishing and installing the appropriate fittings necessary to inject and blow-off the grout in a manner acceptable to the Engineer;
4. Completely filling the designated pipe with an approved grout material;

City-wide Meter, Hydrant, and Valve Installation and Replacement
Contract 18-C-00030

5. Removing injection and blow-off pipes and fittings, and plugging tapped plugs and caps;
6. Removing excess concrete from the trench; and
7. Backfilling and compacting the trench.
8. Cleaning up and restoring the job site which shall include re-grading the terrain; and
9. Removing and legally disposing of all waste materials.

Restoration shall be paid separately under the appropriate pay item.

Payment shall be made under:

<u>Item No.</u>	<u>Description</u>	<u>Unit</u>
9400	Grout abandoned pipe	CY

C9.41 Miscellaneous Backfill

When authorized by the Engineer, the Contractor shall provide all labor, equipment and materials to place and compact replacement backfill soils picked-up from the Water Department Distribution Yard (or furnish, place, and compact Contractor-provided backfill soils) as required to: 1) complete Restoration Work Orders; or 2) to replace excavated backfill soils removed from the site by others; or 3) to backfill voids created whenever large service vaults or large meters are removed (per Contract Pay Items 9600 or 9601); or as otherwise authorized by the Engineer. Acceptable soils materials and installation shall be as specified in Technical Specifications section T2.04 Trenching, Backfilling and Compacting.

Payment for backfill provided shall be per compacted cubic yard. Contractor shall provide digital photographs of excavations to be backfilled, taken prior to fill placement, depicting measuring tools (measuring tape for length and width, rod or stick for depth) clearly indicating the length, width and depth of the trench backfilled.

Payable limits for backfill shall exclude depth (thickness) of required base course and surface course – photos provided should clearly show these exclusions.

Payment shall be made under:

<u>Item No.</u>	<u>Description</u>	<u>Unit</u>
9410	Place and compact backfill soils	CY
9411	Furnish, place and compact backfill soils	CY

C9.50 Incidentals

City-wide Meter, Hydrant, and Valve Installation and Replacement
Contract 18-C-00030

The Contractor shall provide all labor, equipment and material for reinforced concrete construction and repairs, replacement of various sizes of vitrified clay sanitary sewer pipes, and repair of sanitary laterals hit but that were improperly marked (“improperly”, as defined in the SSOCOF “Damage Prevention Guide” and Chapter 556, F.S.). See Contract Documents Specific Provision Section S-20.01.

Reinforced concrete construction can include concrete pads, concrete vault walls, ditch pavement, headwalls, manholes, inlets, shocks pads, concrete "dead-man" restraints, etc.

For any pipeline construction work orders issued, if requested by the Engineer, the Contractor shall provide all labor, equipment and materials for professional quality video photography documentation of the preconstruction site condition along the proposed pipeline route.

Under this Section, payment shall be made for:

1. Furnishing, forming and placing min. 3,000 psi concrete with reinforcement as required;
2. Furnishing and replacement of standard sand cement rip-rap in reinforced cloth or paper bags; and
3. Restoring sanitary sewer service lines (laterals) by furnishing and installing the necessary C-900, DR 18 green PVC pipe and flexible couplings, in accordance with City Wastewater Department requirements <Pay Item No. 9504>;
4. Replace or restore 4”, 6”, 8” or 10” vitrified clay sanitary sewer pipes (sewer main lines - not laterals) found parallel with and too close to proposed water mains to avoid being compromised by the water construction, with C-900, DR 18 green PVC pipe and flexible couplings, in accordance with City Wastewater Department requirements <Pay Item No. 9502 and 9503>
4. Furnishing professional quality video photography of pre-construction site conditions along proposed pipeline route as specified in these contract documents and as required.
5. Backfilling and compacting the excavation;
6. Cleaning up and restoring the job site which shall include re-grading the terrain; and
7. Removing and legally disposing of all waste materials.

Payment shall be made under:

<u>Item No.</u>	<u>Description</u>	<u>Unit</u>
9500	Furnish, form, place reinforced concrete	CY
9501	Restore riprap (rubble)	CY
9502	Replace 4" or 6" VC sanitary sewer pipe with PVC	LF
9503	Replace 8" or 10" VC sanitary sewer pipe with PVC	LF
9504	Replace damaged but not marked sanitary laterals, with PVC	LF
9505	Furnish video photography	LF

C9.60 Removal and Demolition of Large Service Vaults and Concrete Slabs

City-wide Meter, Hydrant, and Valve Installation and Replacement
Contract 18-C-00030

The Contractor shall provide all labor, materials, equipment and incidentals required to demolish and remove existing large service vaults and/or concrete slabs as shown in the plans or as directed by the Engineer. "Large service" herein refers to vaults or slabs housing or supporting DDCVAs or larger than 3-in. meters, as shown in the appropriate applicable Water Department Standard Construction Details.

The removal and demolition of large service vaults and slabs shall include, but may not be limited to:

1. Excavating the trench;
2. Removing existing large service fittings, including but not limited to valves, check valves and meters;
3. Demolishing concrete vaults including, cutting and removal of top slabs and manholes, cutting and removal of exterior walls to the elevation described in the plans;
4. Demolishing and/or removal of vault bottoms;
5. Demolishing and/or removal of large service concrete slabs;
6. Backfilling and restoring demolished areas;
7. If designated by the Engineer, transporting removed large service fittings to a designated location;
8. Backfilling and compacting the excavation;
9. Cleaning-up and restoring the job site which shall include re-grading the terrain; and
10. Removing and legally disposing of all waste materials.

Pipe and fittings installed in place of the large service fittings removed shall be compensated per the appropriate contract pay items. Payment shall be made for each large service vault demolished and accepted by the Engineer. Payment for fill dirt required will be made under the Pay Items 9410 or 9411.

Payment shall be made under:

<u>Item No.</u>	<u>Description</u>	<u>Unit</u>
9600	Demolish and Remove large service vaults	EA
9601	Demolish and Remove large service concrete slab	EA

C9.70 Rock and Muck Removal

The Contractor shall provide all labor, equipment and materials to remove and replace unsuitable or unstable trench materials with suitable materials. The removal and replacement of trench materials shall include, but may not be limited to:

1. Furnishing all labor, equipment and materials for removing rock, concrete, etc. which cannot be removed with standard trench equipment and methods;
2. Removing rocks and concrete larger than one cubic yard;
3. Removing trench muck or other unsuitable materials encountered within the trench below the pipe invert elevation; and

City-wide Meter, Hydrant, and Valve Installation and Replacement
Contract 18-C-00030

4. Backfilling and compacting the excavation with acceptable backfill soils;
5. Cleaning up and restoring the job site which shall include re-grading the terrain; and
6. Removing and legally disposing of all waste materials.

Payment shall be made for each cubic yard of rock or muck material excavated and removed, and replaced.

Payment shall be made under:

<u>Item No.</u>	<u>Description</u>	<u>Unit</u>
9700	Excavation and removal of rock	CY
9701	Excavation and removal of muck	CY

C9.80 Tree Removal, Planting and Protection

The Contractor shall provide all labor, equipment, and materials to plant trees, remove or protect trees 5 inches in diameter or greater. The removal of a tree shall include but may not be limited to:

1. Removal of a tree and all roots inside the trench;
2. Removal of all roots outside the trench to 12 inches below finished grade;
3. Removal from the job site and proper disposal of all timber, stumps, roots and any other organic material resulting from tree removal; and
4. Cleaning up and restoring the job site which shall include re-grading the terrain; and
5. Removing and legally disposing of all waste materials.

Tree diameter shall be determined by measuring the circumference of the trunk 4-½ feet above existing ground level and divided by 3.14. Payment shall be made by the tree-inch diameter.

Trees less than 5-inches in diameter will be considered as part of the normal trench excavation and will be prorated and included under the appropriate pipeline installation contract item.

Tree protection shall include, but may not be limited to:

1. Root pruning all tree roots along the tree-ward side of the trench with a clean vertical cut as shown on the plans or as indicated by the Engineer.
2. Installing 4-inch to 8-inch pipe under tree root systems by hand excavating, mole excavation or pushing as directed by the Engineer. This shall be considered complete compensation for pipe installation. There will be no additional payment under the standard install pipe item.
3. Furnishing and installing orange fencing for a 1-foot radius around grand oaks in areas where work is being done with heavy equipment;
4. Backfilling and compacting the excavation;

City-wide Meter, Hydrant, and Valve Installation and Replacement
Contract 18-C-00030

5. Cleaning up and restoring the job site which shall include re-grading the terrain; and
6. Removing and legally disposing of all waste materials.

Root pruning shall be performed in accordance with City standards and requirements, and to the satisfaction and approval of the Engineer.

Tree planting shall include, but may not be limited to:

1. Excavation of the tree pits;
2. Furnishing and installing the required number of 2-inch diameter Oak trees including replacing and compacting backfill, as indicated on the plans or as directed by the Engineer;
3. Furnishing and installing required fertilizer or chemical required for planting of trees;
4. Backfilling and compacting the excavation;
5. Cleaning up and restoring the job site which shall include re-grading the terrain; and
6. Removing and legally disposing of all waste materials.

Payment shall be made under:

<u>Item No.</u>	<u>Description</u>	<u>Unit</u>
9800	Remove tree 5 inches in diameter and larger	EA
9801	Root prune	LF
9802	Furnish and install 2-inch diameter Oaks	EA

C9.90 Exploratory Pits

The Contractor shall provide all labor, materials and equipment to excavate exploratory pits at locations designated on the plans or as directed by the Engineer **for the sole purpose of locating existing water lines. This item shall not be used to locate utilities other than water lines.** Payment for the location of utilities other than water lines shall be included in other applicable pay items with no separate compensation.

Additional exploratory pits shall only be allowed, when agreed by the Engineer, to locate water main(s) in areas where uncertainty of pipe location is high, or where its location is (or might be) critical – based on other known utilities in the area. The excavation of the exploratory pits shall include, but may not be limited to:

1. Excavating the pits;
2. Maintaining the pits that include sheeting and bracing or dewatering as may be required or as directed by the Engineer;
3. Backfilling and compacting the excavation;
4. Cleaning up and restoring the job site which shall include re-grading the terrain; and

City-wide Meter, Hydrant, and Valve Installation and Replacement
Contract 18-C-00030

5. Removing and legally disposing of all waste materials.

All work shall be for exploratory pits of **various sizes and depths**. The excavating of exploratory pits shall be paid for per each pit excavated, refilled to original grade and accepted by the Engineer.

Compensation for exploratory pits shall be provided at a fixed rate of \$500.00 per agreed and accepted pit.

Payment shall be made under:

<u>Item No.</u>	<u>Description</u>	<u>Unit</u>
9900	Exploratory Pits	EA
C9.91	<u>NOT USED</u>	
C9.92	<u>Miscellaneous Incidentals</u>	

The Contractor shall provide all labor, equipment and materials for the installation of automatic air release valves and blow-off assemblies.

The work shall include but is not limited to:

1. Furnishing and installing standard blow-off assembly (per Standard Detail 2.16: Blow-off Valve Assembly w/2" PVC or HDPE Pipe, and Detail 2.17: Blow-off Valve Assembly for ≥4" Mains) with the proper size cap or plug and restraint, a two-inch threaded tap, all brass, HDPE or PVC pipe and fittings necessary to adjust the blow-off assembly to proper grade;
 - i. Furnishing and installing 2" gate valve and valve box with concrete pad;
 - ii. Furnishing and installing a #37 HDPE meter box in conformance with the Standard Detail 5.10;
2. Furnishing and installing complete and functional standard air release valve assembly (ARV);
5. Furnishing and installing complete and functional standard air vacuum air release valve assembly (AVAR);
6. Furnishing and installing Pedlock Fiber Optic Pedestal for an ARV or AVAR, in accordance with the Standard Details 2.14 or 2.14C and 2.15, on pipelines of various sizes and depths;
7. Backfilling and compacting the excavation;
8. Cleaning up and restoring the job site which shall include re-grading the terrain; and
9. Removing and legally disposing of all waste materials.

Payment shall be made under:

<u>Item No.</u>	<u>Description</u>	<u>Unit</u>
-----------------	--------------------	-------------

City-wide Meter, Hydrant, and Valve Installation and Replacement
Contract 18-C-00030

9920	Furnish and install blow-off assembly w/valve and meter box per Detail 2.16	EA
9921	Furnish and install blow-off assembly w/valve and meter box per Detail 2.17	EA
9922	Furnish and install air release valve (ARV) w/pedestal per Detail 2.14	EA
9923	Furnish and install air vacuum air release valve (AVAR) w/pedestal per Det. 2.14C	EA

Additional compensation shall be allowed for the appropriate sized cap and restraint required for blow-offs installed per Detail 2.17, in accordance with the applicable Contract Pay Item.

C9.93 Concrete Block Thrust Restraint

The Contractor shall provide for all labor, equipment and materials to completely furnish and install concrete thrust restraint when authorized by the engineer. The installation of the concrete thrust restraint shall include but not be limited to:

1. Excavating the trench;
2. Maintaining the trench that shall include dewatering and bracing and sheeting where required or as directed by the Engineer;
3. Furnishing and installing approved pre-cast thrust blocks;
4. Furnishing, forming, and pouring thrust blocks;
5. Backfilling and compacting the excavation;
6. Cleaning up and restoring the job site which shall include re-grading the terrain; and
7. Removing and legally disposing of all waste materials.

No additional compensation shall be made to the Contractor for field poured concrete in excess of the amount detailed in the Technical Specification or Standard Details without prior approval by the Engineer.

Payment will not be credited for restraining devices installed in conjunction with fire hydrant installations. Installation of thrusting units for fire hydrants is to be included in the price quoted for installation of fire hydrant assemblies.

Payment shall be made under:

<u>Item No.</u>	<u>Description</u>	<u>Unit</u>
9930	Furnish and Install pre-cast thrust blocks	EA
9931	Furnish, form and pour concrete thrust blocks	CY

C9.94 Asbestos Concrete Pipe

The Contractor shall provide all labor, equipment and materials to cut the pipeline and remove appurtenances (such as valves, fittings, and other materials) as designated in the plans or directed by the

City-wide Meter, Hydrant, and Valve Installation and Replacement
Contract 18-C-00030

Engineer. The Contractor shall provide certification that he is properly licensed with all appropriate Federal, State and Local agencies to perform such work. Cutting asbestos concrete pipe shall include, but may not be limited to:

1. Cutting full circle asbestos concrete pipe with required safeguards against airborne asbestos particles (minimum of 2 cuts);
2. Removal and proper disposal of asbestos concrete pipe;
3. Abandonment of asbestos concrete pipe site, if appropriate;
4. Furnishing and installing grout or cap to plug open ends of buried pipe;
5. When applicable, connecting new pipe to existing asbestos concrete pipe, including furnishing and installing a maximum of two applicable transition couplings as needed to make the connections;
6. Backfilling and compacting the trench including re-grading the terrain;
7. Cleaning up and removing excess water main pipe and appurtenances; and
8. Removal and disposal of all waste materials.

Payment shall be made based the each complete cut into asbestos containing pipe, necessary to replace or remove the pipe. Transition couplings shall be paid for under appropriate fittings item. All appurtenances removed shall remain the property of the Tampa Water Department except the Asbestos Concrete Pipe that shall be the responsibility of the Contractor to provide for proper disposal or transport and disposal.

Payment shall be made under:

<u>Item No.</u>	<u>Description</u>	<u>Unit</u>
9940	Asbestos Concrete Pipe Complete Cut	EA

C9.95 Project Sign

For non-expedited work orders, project signs may be required to be furnished for each project as directed by the Engineer. If directed, the Contractor shall furnish and install a project sign which conforms to the Standard Detail at a location directed by the Engineer at least five (5) working days in advance of the start of construction. The unit price will include the cost of all labor, equipment and materials to furnish and install a new sign or to re-letter and install a sign previously used elsewhere under this contract. The re-lettering shall involve the project description, total cost, scheduled completion date and supplemental project description. In either case, the price shall also include the cost to remove and properly store or dispose of the sign once the work has been completed and accepted by the City, and the area in which the sign was placed shall be restored to original condition. This restoration shall be included in the cost of the sign.

When directed by the Engineer, the Contractor will furnish and install a new sign for each project or shall re-letter and install a sign used on a previous project.

City-wide Meter, Hydrant, and Valve Installation and Replacement
Contract 18-C-00030

Payment shall be made under:

<u>Item No.</u>	<u>Description</u>	<u>Unit</u>
9950	Furnish and install a new sign as directed by the Engineer	EA
9951	Furnish and install a previously used sign with appropriate re-lettering, as directed by the Engineer	EA

C9.96 Separate Mobilization – NOT USED

C9.97 Supplemental Survey Layout – NOT USED

C9.98 Contingency Allowance

The contingency allowance shall be used by the City of Tampa as directed by the Engineer. Payment shall be made as a lump sum to pay for furnishing and installing items required for construction but not listed in the Contract. Contractor shall provide an invoice listing the items and quantities along with the lump sum price. The Engineer may request a cost estimate for a contingency item from the Contractor prior to construction.

Payment shall be made under:

<u>Item No.</u>	<u>Description</u>	<u>Unit</u>
9980	Contingency Allowance	LS

C9.99 Crew Day Allowance – NOT USED

C10.00 Payment and Performance Bond Allowance

The Payment and Performance Bond Allowance shall be paid to the Contractor as a lump sum reimbursement of the actual premium paid for the Bond. Contractor shall provide the payment performance bond as part of the contract agreement and will be reimbursed with the first work order. Reimbursement for the invoice cost of these bond(s) shall be made upon receipt of a certified copy of the invoice for the bond(s) from the Bonding Company to the Contractor.

Payment shall be made under:

<u>Item No.</u>	<u>Description</u>	<u>Unit</u>
10000	Payment and Performance Bond Allowance	LS

TECHNICAL SPECIFICATIONS

T1.00 **GENERAL REQUIREMENTS**

T1.01 **Summary of Work**

The Contractor shall have access to inspect the project area(s) prior to beginning Work Order construction to ascertain existing conditions.

The work will include the furnishing of all services, labor, equipment and certain materials necessary for a complete installation of water lines and appurtenances and shall be performed in a thorough and workmanlike manner, as outlined in Section G-1.02 of the General Provisions. All items implied, usually included, or required for the construction of a complete operating system shall be installed whether or not shown on the plans or specified herein. In general, pipe shall be provided with a minimum of 36 inches of cover.

The Contractor will preserve and protect all existing vegetation such as trees, shrubs and grass adjacent to the sites, as outlined in Sections G-9.02 and G-9.03 of the General Provisions, which do not reasonably interfere with the construction, as determined by the Engineer. It will be the Contractor's responsibility to give written notification, at least 2 days prior to commencement of construction, to any owners or occupants of properties along the construction route. This notification shall be about the pending construction, in order to allow the said owners or occupants an opportunity for removing from the work site any bushes, flowers, plantings, trees etc. they wish to save that are within the limits of construction. The Contractor will be responsible for all unauthorized cutting or damaging of trees and shrubs, including damage due to careless operation of equipment, stockpiling of materials or tracking of grass by equipment. The Contractor will be liable for, or will be required to replace or restore at no additional expense to the City, all vegetation not protected or preserved as required herein that may be damaged or destroyed.

City-owned utilities within project limits will include water, reclaimed water, wastewater, drainage, and traffic signal cables. All other utilities present within City of Tampa rights-of-way are considered private utilities. Private utilities are responsible for locating their utilities prior to construction and, if required, relocating and/or temporarily supporting their utilities to allow the safe construction of the work under this contract. Private utilities must provide this service without charging a fee to the City's Contractor.

City-owned utilities and structures not shown on Contract Drawings to be removed and replaced or relocated for Work Order Work shall be protected in place and utility service shall be maintained. Where temporary conflicts occur between existing City-owned utilities and the new construction, the Contractor shall protect in place or relocate said utilities and maintain utility service all to the satisfaction of the City. Utilities and structures shown on the drawings to be removed and replaced or relocated by the Contractor shall conform to the requirements of the applicable technical specifications.

Record drawings for existing gravity sewer and laterals along the project route are often not complete. The Contractor shall be prepared to immediately repair any active sewer lateral connection damaged during construction. If the location of active sewer laterals conflict with the proposed location of the water main, the Contractor shall immediately notify the City, who will direct the Contractor on how to resolve the conflict. The Contractor may be required to reroute the sewer lateral either over or under the proposed water main.

T1.02 **Coordination**

The Contractor shall provide for the complete coordination of the construction effort including the work of subcontractors, the effort of independent testing agencies and the interrelated work with the City where tie-ins to existing facilities are required.

It shall be the Contractor's responsibility to alert the Engineer at least two working days in advance of construction, to any conflicts or potential conflicts with the proposed work. Failure of the Contractor to review the job site and alert the Engineer to any conflicts shall relieve the City from compensating the Contractor for any cost arising from any remedial action necessary to resolve the conflict with the proposed work.

All water lines, storm drains, sanitary sewers, gas or other pipe, telephone or power cables or conduits, all individual service connections and all other obstructions, whether or not shown on the plans, shall be supported where adjacent to or crossing the new utility line excavation in a manner acceptable to the Department and the respective utility owner. Wherever existing utility structures or branch connections leading to sanitary sewers or to storm drains, or other conduits, ducts, pipes, or structures present obstructions to the grade and alignment of the pipe, they shall be permanently supported, removed, relocated, or reconstructed by the Contractor through cooperation with the owner of the respective utility, structure, or obstruction involved. In those instances where their relocation or reconstruction is impractical, a deviation from line and grade will be authorized and the changes shall be made in the manner directed by the Engineer.

Approximate locations of known water, sanitary, drainage, power and telephone installations in the vicinity of new work are shown according to the best information available at the time of preparation of the drawings, but do not purport to be absolutely correct, and must be verified in the field by the Contractor. The Contractor shall obtain the location, elevations, and dimensions of all existing utilities, structures, and other features affecting his work prior to construction.

In addition, careful coordination with the work of other contractors may be required if other work is underway within the project area.

Working adjacent to and crossing other utilities can be expected to be commonplace on this project. The Contractor, as outlined in Article G- 1.03 of the General Provisions, shall coordinate his construction schedule with the various utility companies as well as affected local agencies involved prior to starting the project along with a minimum of 48 hours of notice to when construction will commence in an area, in order to permit field location of utility lines prior to construction. A toll free number (811) is available to assist in such coordination efforts. This number is for the utility notification center, a program known as Sunshine State One Call of Florida, but may not totally represent all utilities involved in the construction area. The Contractor is responsible for contacting the utility notification center and to immediately notify the Contract Administration Department (813-635-3432) of the "Location Request Number" obtained.

The various agencies or utilities possibly affected by the work include but are not necessarily limited to the following:

City of Tampa
Wastewater Department
306 E. Jackson St. (390A6N)
Tampa, FL 33602
DPW Traffic Transportation

Florida Dept. Transportation
2820 Leslie Rd
Tampa, FL 33619
Hillsborough County

306 E. Jackson St., (290A4E)
Tampa, FL 33602

Planning & Development Mgmt. Dept.
P.O. Box 1110
Tampa, FL 33601

Hillsborough County Right of Way Management office
5701 East Hillsborough Avenue
Suite 1222
Tampa, Florida 33610

All utilities shall be kept in operation except with the express written consent of the utility owner. It will be the Contractor's responsibility to preserve existing utilities. Any and all damage to existing utilities as a result of the Contractor's actions shall be repaired to the satisfaction of the utility owner and the City at the Contractor's expense.

Where connections are made to existing mains or other shutdowns are necessary, permission must be obtained and arrangements must be made with the Water Department for removing from service those mains that will be affected. Shutdowns must be held to a minimum in both number and duration, and accomplished at times acceptable to the Water Department. No valve or other control device on the existing system shall be operated by the Contractor except as detailed in the Specific Provisions, sections S-31.01 - Shutdowns. Additionally, any service meter that is temporarily removed, after being approved by the Water Department, shall be returned to the original service address from which it was removed.

T1.03 Field Engineering

Each element of the work is subject to review by the Engineer, prior to proceeding with the next element; however, this shall not relieve the Contractor of the responsibility for delivering to the City a project completed in conformance with the contract plans and specifications and guaranteed as stipulated.

T1.04 Abbreviations and Symbols

Various abbreviations and symbols may be used or referenced in these specifications and contract plans. Symbols are generally explained on the sheet of the plans entitled "Location Map, Legend and General Notes". Abbreviations commonly used, along with their full reference, are as follows:

- Cu.Yds. (CY) - Cubic Yards
- CIP - Cast Iron Pipe
- DIP - Ductile Iron Pipe
- DIPRA - Ductile Iron Pipe Research Association (formerly CIPRA)
- EA - Each
- ED - Each Day
- FDEP - Florida Department of Environmental Protection
- FDOT - Florida Department of Transportation
- FL - Flanged Joint
- HDD - Horizontal Directional Drilling
- HDPEP - High Density Polyethylene Pipe
- Lin. Ft. (LF) - Lineal Foot
- LS - Lump Sum

- mg/l - Milligrams per Liter
- MJ - Mechanical Joint
- MH - Man Hole
- NSF - National Science Foundation
- OSHA - Occupational Safety and Health Administration
- ppm - Parts per Million
- psi - Pounds per Square Inch
- PVCp - Polyvinyl Chloride Pipe
- RFO - Restoration for Others
- RFS - Restoration for Self

- RPR - Resident Project Representative
- Sq. Ft. (SF) - Square Feet
- Sq. Yds. (SY) - Square Yards
- TN - Ton
- WOW - Work with Other Water construction
- NAVD88 - North American Vertical Datum 1988

T1.05 Submittals, Shop Drawings, Product Data and Samples

The Contractor shall submit 4 copies of shop drawings as stated in Article G-3.02 of the General Provisions, plus those copies necessary for his own requirements in accordance with Section 3 of the General Provisions. The shop drawings shall have been checked and stamped approved by the Contractor and identified as the Engineer may require. This data shown in the shop drawings shall be complete with respect to dimensions, design criteria, materials of construction, and the like, to enable the Engineer to review the information required. The data shown on the shop drawings shall include, in addition to that specified in the General Provisions, reference to specification section, drawing number, item identification on catalog cuts and like information to expedite review. Incomplete submissions will be returned without action.

Items proposed for use that are on the Water Department's pre-approved material list will not be required to go through the shop drawing submittal process - provided that the list of materials is submitted to and approved by the Engineer in advance of the start of construction.

The Engineer will review and return one (1) set of the shop drawings along with those sets submitted by the Contractor over and above the quantity required by Article G-3.02 of the General Provisions. The returned sets shall bear the Engineer's comments and shall be returned with reasonable promptness. The Contractor's stamp of approval on any shop drawing shall constitute a representation to the Engineer that the Contractor has either determined and verified all field construction criteria, materials, catalog numbers and similar data or he assumes full responsibility for doing so, and that he has reviewed or coordinated each shop drawing with the requirements of the work, contract documents and technical specifications.

The Engineer's review of a shop drawing is only for general conformance with the design concept of the project, and shall not relieve the Contractor from his responsibility for and deviation from the requirements of the contract documents or technical specifications, unless the Contractor has, in writing, called the Engineer's attention to such deviation at the time of the shop drawing submission and the Engineer has given written approval to the specific deviation. Any review by the Engineer shall not relieve the Contractor from his responsibility for errors or omissions in the shop drawings.

One complete set of reviewed shop drawings, product data and samples shall be kept at the site at all times. During the work specified as shown on the shop drawings, the Contractor shall make no deviations from the reviewed drawings, and the changes made thereon by the Engineer, if any.

When required by the Engineer, shop drawings or product data shall be submitted for, but shall not be necessarily be limited to, the following:

- Ductile iron pipe and fittings
- Gate valves and butterfly valves
- Tapping valves and sleeves
- Joint restraints
- Fire Hydrants
- Air release valves and Pedestals
- Casing pipe for jack and bores
- Concrete mix design, reinforcing steel and pre-cast items

Whenever a standard of quality is established by a reference specification, the Contractor shall submit a certificate by the manufacturer that the material supplied meets the requirements of both these technical specifications and the referenced specifications and standards.

T1.06 Quality Control

In addition to the inspection and testing outlined in Section 5 of the General Provisions, compaction/density tests also shall be required.

For tests required by the Technical Specifications regarding soil compaction, asphalt testing and concrete cylinder strength, the City shall appoint and perform inspection and testing. The Contractor shall cooperate; furnish samples of materials, design mix, equipment, tools, storage and assistance as requested; notify Engineer a minimum of 24 hours prior to expected time for operations requiring services; make arrangements and pay for additional samples and tests required for Contractor's use.

Retesting required due to non-conformance with specified requirements shall be performed by the City at the direction of the Engineer. Payment for retesting will be charged to the Contractor by deducting inspection or testing charges from the Contractor's payment.

T1.07 Materials and Equipment

A) General

Materials and equipment incorporated into Work Orders shall meet the requirements of Section 4 of the General Provisions and these specifications. The Contractor shall furnish satisfactory evidence of the quality and kind of materials and equipment as well as guarantees or warranties provided by the manufacturer. It will be necessary to submit a copy of all delivery tickets for materials used on the project, regardless of the basis of payment.

Materials, supplies or equipment to be incorporated into the work shall not be purchased by the Contractor or subcontractors subject to a chattel mortgage or under a conditional sale contract or other agreement by which

an interest is retained by the seller.

All materials and equipment shall be applied, installed, connected, erected, used, cleaned, finished and conditioned in accordance with the instructions of the applicable manufacturer, fabricator or processor except as otherwise provided in the Contract Documents. At the time that any piece of equipment is placed in service or operation at the construction site, the Contractor shall arrange for a qualified representative of the manufacturer to be present for the purpose of inspecting, approving and adjusting the equipment installation. He shall remain on the job to instruct the City's personnel in proper operation and maintenance and shall remain until the equipment is operating in a satisfactory manner.

B) Quality Standards

If a standard of quality for items of equipment is established by reference on the plans or in the specifications to specific manufacturer's products, materials or construction and/or fabrication, items of equipment shall equal or exceed the standard of the referenced product as outlined in Section G-4.05 of the General Provisions.

The Engineer shall be the sole judge of material or equipment equality. The burden of proof of equality rests with the Contractor. Qualities described and shown refer to minimum criteria the Engineer will use in considering equipment proposed for the project.

It is not the intent of the Contract Documents to function as proprietary specifications. Where a particular manufacturer make and model are cited and specifically required for interchangeability of parts and to match existing equipment, this has been stated in the specifications.

C) Transportation and Handling

Materials and equipment shall be loaded and unloaded by methods affording adequate protection against damage. Every precaution shall be taken to prevent injury to the material or equipment during transportation and handling. Suitable power equipment will be used and the material or equipment shall be under control at all times. Under no condition shall the material or equipment be dropped, bumped or dragged. When a crane is used, a suitable lift sling shall be used.

The crane shall be placed so that all lifting is done in a vertical plane. Materials or equipment skid loaded, palletized or handled on skidways shall not be skidded or rolled against material or equipment already unloaded.

Materials and equipment shall be delivered to the job site by means that will adequately support it and not subject it to undue stresses. Material and equipment damaged or injured in the process of transportation, unloading or handling shall be rejected and immediately removed from the site. They shall be replaced with materials that meet all requirements of the contract documents and are suitable to the Engineer.

D) Storage and Protection

Materials and equipment shall be stored in a manner and at a location acceptable to the Engineer to insure the preservation of their quality and fitness for the work and which precludes damage or injury and affords protection against weather staining, corrosion or vandalism. Skidded or palletized materials or equipment

shall not be stacked. Electrical equipment shall be stored indoors or under cover. Sheet materials shall be stored in a manner that affords free drainage with no ponding of water. All equipment shall be stored in a secure area.

Replacement of materials or equipment damaged, destroyed or lost through improper, inadequate or careless storage shall be the Contractor's responsibility.

Stored materials and equipment shall be readily and easily accessible to facilitate inspection.

T1.08 Cleaning and Restoring

Prior to final acceptance, all rubbish and unused material due to or connected with the construction shall be removed and the premises left in a condition acceptable to the City. All damaged areas shall be repaired, and all excess earth and rubble removed. Payments due may be withheld due to failure to comply with these requirements.

Any and all existing facilities and/or conditions shall be restored to original condition or better before final payment and acceptance is made by the City.

T1.09 Preconstruction Photography

When directed by the Engineer, the Contractor shall furnish all labor, materials, equipment, and incidentals required to videotape as determined and approved by the Department, that all areas within the project are as shown in the drawings and as specified herein.

A professional video photographer who is fully experienced and qualified with the specified equipment shall perform the photography.

The total audio-video system and the procedures employed in its use shall be such as to produce a finished product that will fulfill these technical requirements. The video portion of the recording shall produce bright, sharp, clear pictures with accurate colors and shall be free from distortion or any other form of picture imperfection. All video recordings shall, by electronic means, display on the screen the time of day, the month, day and year of the recording. This time and date information must be continuously and simultaneously generated with the actual recording. The audio portion of the recording shall produce commentary of the camera operator with proper clarity and be free from distortion at a nominal sound level of 40-50 decibels.

The color video camera used in the recording shall be capable of producing an output viewable in industry standard DVD format. It shall be capable of being viewed utilizing a TV/DVD player and/or a PC with a DVD drive/player. The DVD provided must be capable and authorized to allow reproduction by the City of Tampa and not be copyright protected. The DVD's provided must be single sided, 4.37 computer GB capacity (DVD-5). Multiple DVD's may be provided if necessary to show complete detail of the project. Video output from camera(s) must utilize a minimum of 8:1 zoom. The DVD shall be new and shall not have been used for any previous recording.

Video recording shall be accomplished along all routes approved by the Department which have

any construction performed by the Contractor with a total length greater than 100 lineal feet. Videotaping shall include any approved staging and storage areas and the route between the staging and storage areas and the project site when an off-site area is used.

When viewed, the DVD shall show the entire length of construction from right-of-way line to right-of-way line. Existing conditions should be apparent to the viewer along the length of construction. Camera pan, tilt zoom-in and zoom-out rates shall be sufficiently controlled such that recorded objects shall be clearly viewed during videotape playback. In addition all other camera and recording system controls such as lens focus and aperture, video level, pedestal, chrome, white balance and electrical focus shall be properly controlled or adjusted to maximize picture quality.

Taping done shall show the proposed construction areas in an oblique view (30 degrees). The average rate of travel during a particular segment of coverage shall be directly proportional to the number and size of the surface features within the construction area's zone of influence.

Coverage shall include, but not be limited to, all existing driveways, sidewalks, curbs, ditches, streets, landscaping, trees, culverts, catch basins, headwalls, retaining walls, fences, visible utilities, and all buildings located within the zone of influence. Of particular concern are any existing faults, fractures, defects or other imperfections exhibited by the above-mentioned surface features. Close-up coverage shall be recorded in these areas. Audio descriptions shall be made simultaneously with support video coverage.

Engineering drawings shall be referenced, by stationing, in the audio on the tapes. If visible, house numbers shall also be mentioned in the audio. All videotapes shall be permanently labeled and shall be properly identified by videotape number and project title.

A record of the contents of each tape shall be supplied on a video log identifying each segment in the tape by location, i.e., street or easement, viewing side, traveling direction, engineering stationing, house or lot numbers, and all referenced by tape counter numbers.

No construction shall start until pre-construction photography is complete, if directed required by the Engineer. Any portion of the video coverage deemed unacceptable by the Owner will be re-recorded by the Contractor at no additional charge.

T2.00 CONSTRUCTION OF WATER MAINS AND APPURTENANCES

T2.01 Subsurface Investigation

The Contractor shall be responsible for having determined to his satisfaction, the nature and location of the work, and the ground conformation, the character and quality of the substrata, the types and quantity of materials to be encountered, the nature of the groundwater conditions, the character of equipment and facilities needed preliminary to and during the prosecution of the work, the general and local conditions and all other matters which can, in any way affect the work under this Agreement. The prices established for the work to be done will reflect all costs pertaining to that work.

The Contractor will notify the Engineer promptly in writing of any subsurface or adverse physical

conditions at the site which differ materially from those that may be indicated by the Contract Documents or earlier subsurface information in accordance with Section I-2.01 of the Instructions to Bidders and Section G-2.04 of the General Provisions. The Engineer will promptly investigate the conditions and advise the Contractor in writing if further surveys or subsurface tests are necessary. If necessary, the Department will promptly obtain the necessary additional surveys and tests and furnish copies to the Contractor.

T2.02 Site Preparation

A) General

The construction site shall be cleared of all obstructions, stumps roots, and vegetation within the limits required for proper execution of the work in accordance with Section 110, FDOT Standard Specifications, latest edition.

Shrubbery, trees and plants shall be protected as required by the City of Tampa Parks Department ("Parks Department") or the agency having jurisdiction, as shown on the plans, or as directed by the Engineer. Where necessary to remove plantings in order to accomplish the work, such plantings shall be replaced. Trees will be transplanted when feasible, and when a successful transplant is probable. Plantings and trees shall be replaced before the work is accepted.

Foliage, trunks, and roots of trees to remain shall be barricaded by encircling with stakes and flagging at a distance equal to the branch spread or as required by the Parks Department. Stockpiling of materials and movement of equipment shall be avoided within this area. Interfering branches shall be removed without injury to trunks.

Trees, stumps, and large roots within the construction area shall be removed, unless otherwise directed. Topsoil shall be stockpiled for future use. Unsuitable materials shall be removed from the site and properly disposed of by the Contractor. All trees shall be preserved in their natural state unless their removal is directed by the Department. Trees within 20 feet of the construction shall be protected as indicated on the plans or as directed by the Engineer. Trees with trunk diameters in excess of five inches (measured circumference three feet above ground level and divided by 3.14) shall be preserved unless:

1. their removal is directed;
2. they are located within areas scheduled to be paved; or
3. they interfere with utility or pipe trench alignment.

All trenching performed adjacent to tree trunks shall be accomplished in such a manner as to maintain a minimum clearance of at least 10-feet between the pipe and the base of the tree trunks for trees 5-inches in diameter and larger. A minimum of 20-feet clearance shall be maintained for tree trunks classified a grand tree by the Parks Department. When trenching is to be performed closer than the above minimums, root pruning or other protective measures as directed by the Engineer may be required. Tree trimming and root pruning shall be performed by a competent tree specialist who carries proper insurance and is licensed by the City of Tampa.

B) Tree Removal and Tree Trimming

When directed or authorized, tree removal shall comply with the City of Tampa Tree Ordinance, City

Code or ordinances, rules, or regulations of any other governmental agencies having jurisdiction. Within the limits of the water pipeline trench, all trees and roots which have been designated for removal, shall be removed and disposed of by the Contractor to allow for installation of the pipeline without hindrance. All removed trees and roots outside the trench area shall be cleared to a minimum depth of 12-inches below finished grade or as directed by the City. The Contractor shall notify the City when encountering material that is believed to qualify as Tree Removal. The Contractor shall give ample time for the City to inspect the location and make necessary measurements before removal.

After removing a tree, the Contractor shall not proceed with construction of the water pipeline without first restoring the tree removal location to an acceptable condition of repair which meets the City's approval. Satisfactory off-site disposal of timber, stumps, roots or any other materials resulting from removal of trees or roots shall be the sole responsibility of the Contractor. Material shall not be burned or buried on the project site. The location of material disposal shall have the approval of the City. The method of material disposal shall be consistent with City of Tampa standards.

1. When located within the City of Tampa but outside the right-of-way, the following trees require no permit from the City based on Section 13-7, City of Tampa Code.

Australian Pine	Brazilian Pepper
Cherry Laurel	Chinaberry
Queensland Umbrella	Eucalyptus
Monkey Puzzle	Male Mulberry (No Berries)
Mimosa/Woman's Tongue	Queen Palm
Wild Cherry	Citrus
Chinese Tallow	Surinam Cherry
Lead	Carrotwood
Rosewood	Earleaf Acacia
Golden Rain Tree	Shefflera
Silk Oak	Punk
Ear Tree	Eucalyptus

2. All trees to be removed from City rights-of-way shall require a tree removal permit issued by the Parks Department.

C) Tree Planting

Newly planted trees and shrubs will be kept well watered and shall be alive, healthy and vigorous at the time of acceptance of the project by the City, or shall be replaced. Trees will be braced or tied to resist wind conditions until they have taken root.

T2.03 Dewatering

If subsurface water is encountered in trenching or structural excavation work, the Contractor shall adequately dewater the excavation at his expense. No additional payment shall be made for dewatering operations.

The contractor will be required to do any and all sampling that may be required to be in conformance with

the NPDES discharge permit requirements, at no expense to the city.

Subsurface water shall be kept 2-feet or more below the working area until there is no danger of displacement of pipes or structures. Provide and maintain adequate dewatering equipment to remove and dispose of all surface and ground water entering trenches, excavations or other parts of the work. Each excavation shall be kept dry during subgrade preparation and continually thereafter until the pipe (or structure) to be installed or built therein is completed to the extent that no damage from hydrostatic pressure, flotation, or other cause will result. All trenches which extend down to or below groundwater shall be dewatered by lowering and keeping the groundwater level beneath such trench 2-feet or more below the bottom of the trench.

All water collected and pumped shall be disposed of in a manner which will cause no health hazard, flooding or nuisance to the surrounding area and in a manner so as not to degrade the water quality of surrounding water or violate any environmental ordinances or requirements. Water containing debris, sand or heavy sediment shall not be discharged into the storm water system. All permits for the discharge of this water shall be obtained by the Contractor from the appropriate regulatory agency.

T2.04 Trenching, Backfilling and Compacting

Trenching shall be conducted to the limits and grades shown on the plans or as directed by the Department.

The Contractor performing trench excavation on this Contract shall comply with the Occupational Safety and Health Administration's (OSHA) trench excavation safety standards, 29 C.F.R., s.1926.650, Subpart P, including all subsequent revisions or updates to these standards as adopted by the Department of Labor and Employment Security (DLES) as well as The Florida Trench Safety Act as delineated in Florida Statute Chapter 553, Part III.

By submission of his bid and subsequent execution of this Contract, the Contractor certifies that all trench excavation done within his control shall be accomplished in strict adherence with OSHA trench safety standards, including all revisions and updates to these standards as adopted by the Department of Labor and Employment Security, as well as to The Florida Trench Safety Act as delineated in Florida Statute Chapter 553, Part III.

The Contractor also agrees that he has obtained or will obtain identical certification from his proposed subcontractors that will perform trench excavation prior to award of the subcontracts and that he will retain such certifications in his files for a period of not less than three years following final acceptance.

The Contractor shall consider all available geotechnical information in his design of the trench excavation safety system.

Dewatering operations shall be maintained until Work Order Work is complete and the trench has been backfilled sufficiently to prevent movement or flotation of the pipe.

The use of trench-digging machinery will be permitted except in places where its operation will cause damage to other utilities, trees, buildings, or existing structures above or below ground; in which case hand methods will be employed.

The trench width and trenching method may vary with, and depend upon the depth of the trench and the nature of the excavated material encountered; but in any case shall be of ample width to permit the pipe/appurtenance to be laid and jointed properly and the backfill to be placed and compacted properly. The minimum width of unsheeted trench, at the bottom where the pipe is to be laid, shall be one foot greater than the nominal diameter of the pipe, except by consent of the Department. The maximum clear width of trench and the trench support system shall be in accordance with OSHA requirements.

Where sheeting and bracing are used, the trench width shall be increased accordingly. Trench sheeting shall be cut off at a level of at least 1 foot above the top of the installed pipe and shall be left in place until the pipe has been laid, tested for defects, repaired if necessary, and until the earth around the pipe has been compacted to a depth of 2 feet over the top of pipe.

Unless otherwise specified, the trench shall be AWWA C600 Type 2 as shown on the Standard Details "Typical Trench, Bedding and Backfill Detail". The trench shall have a flat bottom conforming to the depth to which the pipe is to be laid. The pipe shall be laid upon sound soil, cut true and even, so that the barrel of the pipe will have equal bearing for its full length. Bell depressions of ample dimensions shall be dug at each joint to permit proper pipe jointing.

In the event the Contractor excavates below the elevation required without approval from the Department, he shall refill with approved material and thoroughly consolidate. If, in the opinion of the Engineer, the trench bottom cannot support the pipe, a further depth and/or width shall be excavated and refilled to pipe foundation grade or other approved means shall be adopted to assure a firm foundation for the pipe.

All excavated material shall be piled in a manner that will not endanger the work and that will avoid obstructing sidewalks and driveways. Gutters shall be kept clear or other satisfactory provisions made for street drainage. All material removed from the trench on an improved area shall be removed from the site by the Contractor at the Contractor's expense.

Material removed from an unimproved area may be reused if, in the opinion of the Engineer, it is suitable and if local conditions permit reuse. All materials suitable for reuse must be stored separate from the general excavated material. All backfill material must be approved by Engineer prior to placement. If replacement backfill is required, when authorized and approved by the Engineer, the Contractor shall provide backfill soils either picked-up from the Water Distribution Yard or self-provided, as specified in Contract Pay Item description C9.41 – Miscellaneous Backfill. Compensation will be provided per Contract Pay Item 9410 or 9411.

Backfill material shall be free from cinders, ashes, refuse, organic matter, boulders, rocks or stones, or other material that in the opinion of the Engineer is unsuitable. Rocks up to 6-inches in their greatest dimension may be used for backfill from 1 foot above the top of the pipe up to the subgrade of the pavement unless otherwise specified by the Engineer.

All trenches shall be backfilled by hand, from the bottom of the trench to the centerline of the pipe/appurtenance in layers of 6 inches. Compaction shall be performed by tamping. Backfill material shall be deposited in the trench for the full width on each side of the pipe/appurtenance. From the centerline of the pipe to the specified grade, the pipe shall be backfilled by hand or by approved mechanical methods.

Compaction and consolidation shall be done in accordance with the requirements of the agency having jurisdiction. Unless requirements of the agency having jurisdiction are more stringent, all compaction shall conform to the following:

A. Impervious (paved) Surface Areas

The space between the pipe and the trench sides shall be packed-full by hand-shoveled earth, free from lumps, carefully deposited in layers not exceeding 6 inches in depth. Such material shall be placed equally on each side of the pipe, and at the same time tamped in a manner acceptable to the Department, until enough fill has been so placed and compacted to the centerline of the pipe. From this point to 12 inches above the pipe, backfill shall be placed and compacted in uniform loose lifts no greater than 6 inches to a density that is at least 98% of the maximum modified proctor density (as determined by the Modified Proctor Density Test Method (ASTM D-1557)). The balance of the soils backfilled from this point to the top of the trench shall be placed and compacted in loose lifts not to exceed 12 inches to a density at least 98% of the maximum modified proctor density.

B. Pervious (non-paved) Surface Areas

The space between the pipe and the trench sides shall be packed-full by hand-shoveled earth, free from lumps, carefully deposited in layers not exceeding 6 inches in depth. Such material shall be placed equally on each side of the pipe, and at the same time tamped in a manner acceptable to the Department, until fill has been placed and compacted from the bottom of the trench to the centerline of the pipe. From this point up to grade, backfilled soils shall be placed and compacted in uniform loose lifts no greater than 12 inches, to a density that is at least 95% of the maximum density as determined by the Modified Proctor Density Test (ASTM D-1557).

T2.05 **Pipeline Installation**

A) General

During shipping, delivery and installation of pipe and accessories, materials shall be handled in such a manner as to prevent any damage. Particular care shall be taken not to injure pipe coatings. All pipe, fittings, valves and other material shall be subject to inspection and acceptance by the Department after delivery and no broken, cracked, misshapen, imperfectly coated, or otherwise damaged or unsatisfactory material shall be used. When a defect is discovered, the damaged portion shall not be installed. With the Department's approval, cracked pipe shall have the defect cut off at least 12 inches from the break in the sound section of the barrel.

Installations shall be according to AWWA Standard C600 (ductile iron pipe), AWWA C605 (PVC pipe), AWWA C906 (PE pipe), AWWA Manual of Water Supply Practices M55 (PE Pipe Design and Installation), pipe manufacturer's recommendations, and as described in these technical specifications. Disinfection of all water mains shall be in accordance with AWWA C651.

All connections to existing piping systems shall be made as shown or indicated on the plans after consultation and cooperation with the Department. No such connection shall be made until all requirements of these specifications as to tests, cleaning, flushing and disinfection of new work have been met, and the planned cut-in to the existing line has been approved by the Department. Where connections are made between new work

and existing work, the connections shall be made in a thorough and workmanlike manner using proper fittings and specials. Some such connections may have to be made during off-peak hours if required by the Department.

B) Underground Pipelines

Proper implements, tools and facilities satisfactory to the Department shall be provided and used. Pipe, fittings, valves and appurtenances shall be carefully lowered into the trench piece by piece. Under no circumstances shall piping materials be dropped or dumped into the trench. Pipe and fittings shall be carefully examined for cracks and other defects while suspended above the trench immediately before installation in final position. If damage occurs to any pipe, fitting, valve or piping accessory in handling, the damage shall be immediately brought to the Engineer's attention. The Engineer shall prescribe corrective repairs or rejection of the damaged items.

Lumps, blisters and excess coating shall be removed from the bell- and-spigot end of each pipe. The outside of the spigot and the inside of the bell shall be wire brushed and wiped clean, dry and free from oil and grease before the pipe is laid. Pipe joints shall be made up in accordance with manufacturer's recommendations.

For DIP and PVCP, upon satisfactory excavation of the pipe trench and completion of the pipe bedding, a continuous trough for the pipe barrel and recesses for the pipe bells, or couplings, shall be excavated by hand digging. When the pipe is laid in the prepared trench, true to line and grade, the pipe barrel shall receive continuous, uniform support and no pressure will be exerted on the pipe joints from the trench bottom. All ductile iron pipe shall be wrapped in polyethylene encasement (polywrapped) as shown in the Standard Detail. The polywrap and tape shall be blue for potable water and green for sanitary sewer force mains.

Pipe manufactured from materials, which are classed as flexible for purpose of pipe design shall be bedded true to line and grade with uniform and continuous support from a firm base and installed in accordance with manufacturer's recommendations. Blocking shall not be used to bring the pipe to grade. Backfill material shall be properly placed and compacted to provide lateral restraint against deflection in the pipe diameter. Care shall be exercised to avoid contact between the pipe and compaction equipment.

Pipe interior surfaces shall be thoroughly cleaned of all foreign matter before being gently lowered into the trench and shall be kept clean during laying operations by means of plugs or other approved methods. Pipe 12-inches in diameter and smaller may be cleaned by flushing in place under the supervision of the Engineer if in the Engineer's opinion the pipe contains dirt that can be so removed; if not, then the pipe shall be cleaned by swabbing and flushing before it is placed in the trench. All pipe 12-inches in diameter and larger shall be thoroughly cleaned, by appropriate means, before placing it in the trench. During suspension of work for any reason at any time, including the end of each workday, a watertight plug shall be placed in the end of the pipe last laid to prevent mud or other foreign material from entering the pipe. Sufficient backfill material shall also be placed over the pipe to prevent flotation. Lines shall be laid straight and depth of cover shall be maintained uniformly with respect to finished grade, whether grading is completed or proposed at time of pipe installation. Pipelines shown on the plans to be laid at grade or with a specified slope shall be installed with the invert conforming to the required elevations, slopes and alignment shown and with the pipe bottom uniformly and continuously supported by a firm bedding and foundation. Pipe installed using horizontal directional drill will be installed within the tolerance outline herein.

The work shall at all time progress with caution so as to prevent damage to underground obstructions, both

known and unknown. Should an obstruction not shown on the plans be encountered, the Engineer shall be immediately notified so that alteration to the plans can be made should realignment be necessary. The Contractor shall notify the Engineer far enough in advance to allow the realignment to be accomplished by deflection in the pipe joints or adjustment in the drilling operation.

Only EPDM gaskets will be used for PVC pipe and ductile iron pipe. Wherever it is necessary to deflect pipe from a straight line, either in the vertical or horizontal plane, the amount of deflection allowed shall not exceed 80% of that allowed under AWWA Standard C 600 (DIP) for the type of joint being installed and in accordance with the manufacturer's recommendations. Only after the pipe has been properly homed will it be allowed to be deflected. No deflection will be allowed in PVC pipe joints – however, longitudinal bending of PVC pressure pipe in conformance with AWWA C605 will be allowed.

Water mains crossing or parallel to storm sewer, sanitary sewer and gas mains shall have a minimum of 12 inches vertical clearance and a horizontal clearance which shall comply with all State, Local and Federal regulations and requirements. A minimum 3-foot pipe wall to pipe wall clearance shall be maintained between all utilities and water main. Any exceptions to these standards must be approved in advance by the Engineer. When crossing or parallel to storm sewer and sanitary sewer mains, including gravity sewers and force mains, with less than the minimum clearances, the Contractor shall protect the water main as shown on the plans or, in a manner acceptable to the Engineer. Where ductile iron or PVC pipe water mains are crossing sewer service laterals with less than the require 12 inch minimum clearance, the Contractor shall make the necessary adjustments to center a full joint of water main (10 feet min.) at the conflict point, or replace 10 feet of the lateral with PVC pipe meeting AWWA C-900 Class 150 centered over the conflict point. Sewer laterals, when replaced, shall be installed in accordance with the City of Tampa Department of Sanitary Sewers technical manual, latest edition.

1. Thrust Restraint

All plugs, caps, hydrants, tees, bends and other fittings on pressure pipelines shall be provided with restrained joints as indicated on the plans, or as directed by the Engineer. Thrust blocks or reaction blocks may only be used when approved in advance by the Engineer.

2. Joints

The joints of all pipelines shall be made absolutely tight. The particular joint used shall be acceptable to the Department prior to installation. The gasket material for all joints shall be EPDM and shall be properly positioned before the pipe is lowered into the trench. The joining of the pipe shall proceed in accordance with the manufacturer's requirements.

a) Push-on Joints

In making up the push-on type joint, the EPDM gasket shall be placed in the socket with the large round end entering first so that the groove fits over the bend in the seat. A thin film of lubricant (approved by the manufacturer) shall then be applied to the inside surface of the gasket that will come in contact with the entering pipe. The plain end of the pipe to be entered shall be thoroughly brushed with a wire brush and placed in alignment with the bell of the pipe to which it is to be joined. The joint shall be made up by exerting sufficient force on entering pipe so that its plain end is moved past the gasket until it seats as per manufacturer's recommendations. Backhoe buckets or excavation equipment shall not be applied directly to

the pipe.

b) Mechanical Joints

Where shown on the plans, or where in the opinion of the Department, settlement or vibration is likely to occur, all pipe joints of pressure pipelines shall be bolted mechanical type as specified herein.

Mechanical joints shall be made up using high-strength, low-alloy steel bolts and rubber gaskets having either plain or duck tip as recommended by the manufacturer. All types of mechanical joint pipes shall be laid and jointed in full conformance with the manufacturer's recommendations. Only especially skilled workmen shall be permitted to make up mechanical joints.

Mechanical joints shall be centered in the bells. Soapy water shall be brushed over the gasket just prior to installation. The EPDM gasket and gland shall be placed in position, the bolts inserted, and the nuts tightened finger tight. Mechanical joints shall be assembled in accordance with AWWA Standards. The joints shall be tightened on opposite sides of the pipes by means of a torque wrench in such a manner that the gland shall be brought up evenly into the joint. The following range of bolt torques shall be applied:

<u>Bolt Size (dia.)</u>	<u>Range of Torque</u>
3/4"	85 to 95 ft-lbs
1"	95 to 100 ft-lbs

If effective sealing is not obtained at a maximum torque listed above, the joint shall be disassembled and reassembled after thorough cleaning. If the joint is defective, it shall be cut out and entirely replaced or if the Department gives permission, it may be repaired by a suitable clamp.

3. Plugs and Caps

Plugs shall be inserted into the bell ends of all open ductile iron pipe, tees or crosses. All plain ends of pipe and fittings shall be capped.

4. Completion

After the pipe (DIP, PVC, or HDPE) has been installed, inspected by the Engineer and found to be satisfactory, sufficient backfill shall be placed along the exposed areas of pipe to hold it securely in place while conducting the preliminary hydrostatic test. No backfill shall be placed over the ductile iron pipe joints until the preliminary test is satisfactorily completed, leaving them exposed to view for the detection of visible leaks.

Upon satisfactory completion of the preliminary hydrostatic test, backfilling shall be completed.

C) Underground Pipelines-Horizontal Directional Drilling

HDPE pipeline installations shall be in accordance with AWWA C906 (HDPE pipe), AWWA Manual M55 (PE Pipe Design and Installation), ASTM F2164-02 (Field Leak Testing of PE Pipe), pipe manufacturer's recommendations, and as described in these technical specifications. PVC pipeline installations shall be in accordance with AWWA C605, AWWA C900 (or C905), pipe manufacturer's recommendations, and as

described in these technical specifications

Horizontal Directional Drilling

The work specified in this section consists of furnishing all labor, equipment and certain materials and services necessary to install water lines using the horizontal directional drilling (HDD) method of installation, also known as directional boring, of HDPE or PVC pipe. Fittings, valves and appurtenances shall be carefully lowered into the trench piece by piece. Proper implements, tools and facilities satisfactory to the Department shall be provided. Under no circumstances shall piping materials be dropped or dumped into the trench or on the ground. Pipe and fittings shall be carefully examined for cracks and other defects while suspended above the trench immediately before installation in final position. The dragging of HDPE pipe along asphalt or concrete will not be allowed. The Contractor will use above ground rollers or may suspend it to move into position. If damage occurs to any pipe, fitting, valve or piping accessory in handling, the damage shall be immediately brought to the Engineer's attention. Sections of HDPE pipe with cuts or gouges exceeding 10 percent of the pipe wall thickness or kinked sections shall be cut out and the ends rejoined at no additional cost to the Water Department. The Engineer shall prescribe corrective repairs or rejection of the damaged items.

1. Preconstruction Responsibilities

- a) The minimum ground cover over directionally bored water utility lines shall be 36 inches unless otherwise shown on the plans or directed by the Engineer. There shall be at least 12 inches vertical clearance when any water main crosses under a storm sewer or sanitary sewer .
- b) The Contractor shall limit curvature in any direction to reduce force on the pipe during pullback. Ideally, the directional bore should lie in a vertical plane. The minimum radius of curvature shall be no less than that specified by the pipe manufacturer.
- c) The Contractor shall submit design calculations indicating predicted/permissible (maximum safe) pull force, pipe pull rating, and minimum permissible pipe bend radius. Maximum safe pull force shall be included in the submittal. The Contractor assumes all responsibility for proper design of the directional bore. Some factors to be considered in calculating the safe pull force follow:
 - (1) The pullback force will be calculated at the leading end of the pipe behind the pulling head.
 - (2) The frictional resistance is highest just prior to movement and decreases with movement. When pullback ceases, frictional forces and drag forces increase due to the thixotropic nature of drilling mud. The mud starts to gel when it is undisturbed.
 - (3) Buoyant force pushes the pipe up against the top of the borehole, creating frictional drag between the pipe and the borehole.
 - (4) Minimum radius of curvature at the entry and exit pits and throughout the directional drill is limited by the steering capabilities of the boring equipment and the pipe manufacturer's requirements.

- (5) When the bending radius is too small, the safe pulling strength of HDPE pipe may be significantly reduced by the additional tensile stresses due to curvature.
- (6) All bending stresses due to various curvatures in the boring path are additive and should be subtracted from the safe pull force.
- (7) The “safe” pull-load is time dependent.

2. Contractor Responsibilities

- a) Contractor shall supply all labor, supervision, tools and equipment, and materials necessary to install pipe by directional bore method for potable water. Installation of the pipe system includes the installation of water mains, services and/or any other devices or materials deemed necessary for the respective systems and as directed on the plans.
- b) The Contractor shall provide experienced operators to perform directional boring. The Contractor shall have a minimum of four years of experience with similar construction including pipelines. The Contractor shall have performed at least three successful directional drills in each of the tube and pipe diameters specified. Each bore shall have been a minimum of 150 feet in length and shall involve the use of HDPE or PVC pipe. In addition, the Contractor shall have at least 2 years of experience installing potable water lines. References, project scope and owners contact information for each of the aforementioned projects for both directional drill and potable water work shall be furnished to the Engineer prior to the award of this contract.
- c) The Contractor shall be fully responsible for placement of the pipe per the contract documents.
 - (1) The Contractor shall supply experienced persons who have received proper training in the use of the butt fusion equipment according to the recommendations of the pipe manufacturer and butt fusion equipment supplier to perform thermal fusion of the specific HDPE or PVC pipe to be used.
 - (2) Contractor shall supply experienced persons who have received proper training in the use of the electrofusion equipment according to the recommendations of the pipe and fittings manufacturer and electrofusion equipment supplier to perform thermal fusion of the specific HDPE or PVC pipe and fittings to be used.
 - (3) The as-built variance from the specified bore path shall not exceed plus or minus one (1) foot in the vertical plane and plus or minus one (1) foot in the horizontal plane. The Contractor shall notify the Engineer prior to start of the boring operation if these tolerances cannot be met.

3. Equipment

- a) The directional drilling equipment shall consist of directional-drilling machines capable of handling the HDPE or PVC pipe specified. It will be of sufficient capacity to perform the bore, pull back the pipe and shall have a drilling fluid mixing, delivery and recovery system of sufficient capacity to successfully complete the project, a drilling fluid recycling system to remove solids from the drilling fluid so that the fluid can be reused, a guidance system to accurately guide the boring operations and a vacuum truck of sufficient capacity to handle the drilling fluid volume. All equipment shall be in good,

safe operating condition with sufficient supplies, materials and spare parts on hand to maintain the system in good working order for the duration of this project.

(1) The steerable, horizontal directional drilling equipment shall produce a stable fluid lined tunnel with a minimum burial depth of cover of 36-inches for the carrier pipe installation. The system must be able to control the depth and direction of the pipe and must be accurate to a window of ± 2 inches.

(2) The tunneling equipment shall employ drilling fluid that is inert and shall pose no environmental risk and shall be material such as bentonite or a polymer-surfactant mixture producing a slurry of proper consistency.

(3) The hydraulic power system shall be self-contained and free of leaks, with sufficient pressure and volume to power the drilling operation.

(4) Calibration of the electronic detection system shall be verified by either uncovering the tool (head) within the first ten (10) foot of the bore or by verification above ground prior to the start of the bore.

(5) The boring tool (head) shall be remotely steerable by means of an electronic or magnetic detection system. The tool (head) location shall be monitored in three dimensions (offset from the baseline, distance along the baseline and depth of cover) and logged every 50 feet from the drilling machine. This log shall be used to produce an as-built which will be submitted to the Water Department at the conclusion of the project. The boring tool shall pull the carrier pipe through the fluid lined tunnel as it traverses the surface being crossed.

(6) The machine shall have means to monitor and record the maximum pullback force during the pullback operation. The pulling strength of the boring equipment shall not exceed the HDPE or PVC pipe safety pull strength as per the manufacturer's recommendation.

b) The butt fusion machine used to join sections of HDPE or PVC pipe shall have controls and gauges for setting pressures and temperatures used for facing, heating, and fusing.

(1) Facing shall be conducted at a pressure that produces properly faced (squared and true) pipe ends.

(2) Heating pressure should be set so that the pipe ends maintain contact against the heater, but are not forced against the heater (no "contact pressure").

(3) Fusing pressure shall be as recommended by the pipe manufacturer and fusion equipment supplier.

(4) Heater surfaces must be clean and free of contaminants such as dirt, oil, grease, and melted or charred plastic. To clean the heater, only wooden implements and clean, dry, lint-free non-synthetic cloths may be used.

(5) The heater shall be checked periodically for uniform surface temperature using a surface

pyrometer.

- c) An electrofusion machine shall be used to fuse fittings and accessories to pipe. The machine shall be approved for use by the manufacturer of the pipe and the fittings.

4. Directional Bore Pipe and Fittings

HDPE and PVC pipe for directional bores and all associated HDPE fittings (MJ adapters, solid couplings, tapping tees, corporations, flange adapters, etc.) will be furnished by the Contractor as part of the appropriate unit priced pay item.

- a) Pipe and fittings shall be High Density Polyethylene (HDPE) as per AWWA C906. All HDPE pipe shall be pressure class 160 psi, DR 11, and PE code 4710. PVC pipe shall be AWWA C900/C905 PVC, DR 18, and pressure class 235.
- b) Pipe shall be blue, or color-coded blue, to provide identification. Color-coding shall be made by co-extrusion or impregnation and shall consist of stripes running along the entire outside length of the pipe, not more than 120 degrees apart or fully colored co-extruded.

Markings shall include but not necessarily be limited to the following:

- Nominal size and OD base
- Standard material code designation
- Dimension
- Pressure class
- AWWA designation (AWWA C906 or C900 or C905)
- Material test category of pipe

5. Tracer Wire

- a) All plastic piping shall be installed with two continuous, insulated, blue coated, solid #10 gauge UF (Underground Feeder per National Electric Code Article 339) copper tracer wires for water main location purposes by means of an electronic line tracer. The wires must be installed along the entire length of the pipe. The insulation shall be blue in color. Sections of wire shall be spliced together using Burndy YSV14 connectors or other approved method for splicing. Twisting the wires together is not acceptable. Wire ends shall terminate in curb stop boxes installed in concrete valve box pads per Standard Construction Detail 7.02 and 8.07.
- b) Upon completion of the directional bore, the Contractor shall demonstrate to the Water Department that the wire is continuous and unbroken through the entire run of the pipe by providing full signal conductivity (including splices) when energizing for the entire run in the presence of the Engineer. If the wire is broken, the Contractor shall repair or replace it. No payment will be made for pipe installed until the wire passes a continuity test.

6. Fittings and Restrainers

- a) Pipe flange joints shall be made using a flanged adapter, which is butt fused to the HDPE

pipe.

(1) A back-up ring shall be fitted behind the flange adapter sealing surface flange for bolting to the mating flange. Standard back-up rings shall be AWWA C207 Class D for 160 psi and lower pressure ratings.

(2) One edge of the back-up ring shall be chamfered to fit up against the back of the sealing surface flange.

b) Connections between HDPE and mechanical joints shall be made using an HDPExMJ adapter. The MJ adapter shall be fused to the HDPE pipe on one end. The other end of the adapter will be inserted into the MJ fitting. The fitting shall be fully restrained by the installation of an MJ gland or back-up ring behind the adapter flange as the MJ gland or back-up ring is tightened in place.

(1) Properly installed, the joint shall be a watertight and restrained joint.

c) Electrofusion Couplings may be used to join two sections of HDPE pipe together when there is a space constraint that precludes butt fusion.

(1) The electrofusion coupling will be made of HDPE and will incorporate a constant 40-volt fusion coil for purpose of joining the ends of the pipe.

(2) The electrofusion coupling will be installed in conformance with the manufacturer's requirements and recommendations.

d) When connecting HDPE pipe with ductile iron fittings, the angle of entry into the fitting shall not exceed four degrees or 80% of the allowable deflection angle as determined by AWWA C-600. In the event that the entry angle at the point of connection exceeds four degrees of deflection, additional bends shall be installed.

7. Maintenance of Traffic

Erection or installation of appropriate safety and warning devices in conformance with the governing right-of-way authority shall be the responsibility of the Contractor.

8. Construction Requirements

a) General

All directional bore operations shall be contained within rights-of-way and/or easements shown on the plans. Bores may not start after 1:00 PM unless approved in advance by the Engineer.

b) Contractor Responsibilities

(1) The Contractor shall provide the following materials and services for horizontal directional drill installations unless otherwise specified by the Engineer:

- Traffic control
- Tracer wire for carrier pipe (#10 gauge or larger, solid), per Standard Detail
- Site preparation and excavation
- Dewatering – Groundwater Pump or Well Point System as needed
- Sheeting and shoring, as necessary
- HDPE pipe sized in accordance with the plan drawings
- All butt fusion welding and electrofusion welding
- Tie-in to existing pipelines with HDPE, if called for in the plans
- Preliminary site restoration (fill open pits, grading)
- Site clean-up including removal and proper disposal of all waste materials and drilling fluid
- All HDPE fittings, HDPE couplings, and HDPE carrier pipe and all ductile iron pipe, fittings, appurtenances and valves
- Final site restoration (sod, seed, mulch, concrete/asphalt repair)

(2) The Contractor shall ensure that the following items are properly monitored and controlled:

- Calibrate locator/tracking system
- Ensure that the flow of lubricating fluid (i.e. "Bentonite", etc.) is continuous
- Ensure pulling pressure does not exceed pipe manufacturer's specifications
- Fusing of pipe is within pipe manufacturer's specifications
- Post fusion cool down time is calculated and complied with
- Pipe is fused prior to the start of any bore longer than 100 feet

(3) The Contractor shall record horizontal offset from the plan baseline and depth measurements every fifty (50) feet over the course of the bore and provide that data to the City along with a complete as-built. All valves, fittings, points of connection and horizontal or vertical changes from the plans shall also be referenced and shown on the as-built. Data collected by the Engineer does not relieve the Contractor from the responsibility of recording his own data. The Contractor shall log all necessary data from the locator/tracking system:

- Position
- Roll Angle
- Tilt Angle
- Depth
- Temperature of Data Transmitter
- Remaining Battery Life
- Pull Back Force (Maximum pull back force shall be recorded)

(4) The Contractor shall call "Sunshine State One-Call" (phone number: 800-432-4770) at least 48 prior to performing any excavation. The Contractor shall confirm the location of utilities before starting the directional bore.

(5) The Contractor shall perform the horizontal directional drill in accordance with the approved project plans. In no case shall the bore extend into private property unless an easement is

provided prior to start of construction or the Contractor has obtained a temporary construction easement from the property owner. Vertical tolerances shall be within plus or minus 1 foot of elevations shown on drawings. Horizontal tolerances shall be plus or minus 1 foot of alignment shown in drawings. These tolerances shall be met unless required separations for other utilities must be met and puts the bore in conflict. Failure to meet tolerances, if not pre-approved by Engineer, may be grounds for rejecting the bore. The Contractor may, at the discretion of the Engineer, be required to abandon the bore and re-drill a new one at Contractor's own expense.

(6) The Contractor shall provide all structures, safety equipment, and professional services required for the health and safety of the general public and of personnel involved in directional boring work in accordance with the requirements of the Federal, State, and Local Authorities. This includes proof of construction personnel certificates of trench safety training at the time of construction.

(7) The Contractor shall take all measures necessary to protect surrounding public and private property, adjacent buildings, roads, drives, sidewalks, drains, sewers, utilities, trees, structures, and appurtenances from damage due to directional bore work.

(8) The Contractor shall exercise due care at all times and shall not apply more than the safe pull force to the carrier pipe recommended by the manufacturer.

(9) The Contractor shall furnish and install two, insulated, blue coated #10 gauge solid strand copper tracer wires as previously specified herein.

(10) The Contractor shall give 48-hour (two working days) advance notice to the Water Department prior to start of work. The Engineer is required to inspect materials prior to the start of the boring operation and to be on site during the boring operation and installation of the pipe.

(11) The Contractor shall be fully responsible for all steerable, fluid lined directional-boring operations. Any noticeable surface defects resulting from operation of this boring equipment shall be repaired by the Contractor at his own expense. The Contractor is reminded that he is required to take preconstruction videos of the construction site to avoid unwarranted claims for damages resulting from the construction.

(12) The Contractor shall meet all City insurance requirements, as outlined in this document, when working in a City right-of-way or using a City right-of-way use permit.

c) The Water Department shall supply the following materials:

- Large meters
- Small meter for large meter by-pass lines
- Small meters
- Double detector check valve assemblies

d) The Engineer shall witness and verify the Contractor's logging of pertinent data. The Engineer may log his own data in the Department's own Directional Bore Log sheet for the Department's use.

e) Drilling Requirements

(1) The horizontal alignment shall be as shown on the drawings, plus or minus 1 foot. The vertical alignment shall be as shown on the drawings, plus or minus 1 foot. If the Contractor cannot meet these tolerances for whatever reason, he shall confer with the Engineer prior to the start of the bore. The Engineer may approve or disapprove variance requests at his discretion.

(2) All HDPE pipe and tubing and PVC shall have a minimum of 36 inches cover unless otherwise indicated on the plans or directed by the Engineer.

(3) Compound curvatures shall be minimized limited by the maximum deflection as set forth by the HDPE or PVC pipe manufacturer, or AWWA Standards, whichever is more stringent.

(4) The entry angle shall be 12° to 14° (not to exceed 15°). Exit angle shall be 6° to 12° to facilitate the pullback operation. Entry and exit angles are defined as angles from the horizontal. Connection angles between HDPE and PVC pipe and ductile iron fittings shall not exceed 4 degrees.

(5) Erosion and sedimentation control measures and on-site containers shall be installed to prevent drilling mud from spilling out of entry and/or exit pits. Drilling mud will be disposed of off-site in accordance with local, state and federal requirements and/or permit conditions. No other chemicals or polymer surfactant shall be added to the drilling fluid without written consent of the Engineer or until a determination is made by the Engineer that the chemicals to be added are not harmful or corrosive to the facility and are environmentally safe.

(6) Pilot holes shall be drilled on bore path with no deviation greater than plus or minus 1 foot from the design depth over a length of 100 feet. In the event that the allowable deviation is exceeded, the Contractor shall notify the Engineer, and the Engineer may require the Contractor to pull back and re-drill from a location along the bore path before the deviation.

(7) After successfully completing the pilot hole, the borehole shall be reamed to a diameter, which is, at minimum, 25 percent greater than the outside diameter of the pipe being installed.

(8) The Contractor shall not attempt to ream at a rate greater than the drilling equipment and mud system are designed to safely handle.

(9) In the event of a drilling hole blowout or other loss of drilling fluid, the Contractor shall be responsible for restoring any damaged property to original condition and cleaning up the area in the vicinity of the blowout or loss.

f) Pipe Installation

(1) After reaming the borehole to the required diameter, the pipe shall be pulled through the hole. There shall be a swivel and barrel reamer to compact the bore hole walls at the front of the pipe.

(2) Once pullback operations have commenced, the operation shall continue without interruption until the pipe is completely pulled into the borehole. **EXCEPT FOR DRILLING ROD REMOVAL, PULLBACK SHALL NOT CEASE, UNTIL THE PIPE IS COMPLETELY PULLED INTO ITS PERMANENT POSITION.** During the pullback operations, the Contractor shall apply no more than the maximum safe pipe pull pressure as detailed in the approved submittals.

(3) After pullback, HDPE pipe may take several hours or days to recover from the axial strain, or to “relax”. When pulled from the reamed bore hole, the pull-nose shall be pulled out a distance longer than the total length of the pull to avoid having the pull-nose retract back below the bore hole exit level due to stretch recovery and thermal contraction to equilibrium temperature. No connections shall be made until the stretch recovery and thermal contraction cycles are complete.

(4) The pipe entry area shall be graded as needed to provide support for the pipe and to allow free movement into the borehole. The pipe shall be guided into the borehole to avoid deformation of, or damage to, the pipe. Under no circumstances shall the pipe be dragged over an asphalt or concrete surface; above ground rollers or other similar devices shall be used to support the pipe while it is being moved across such surfaces.

(5) The pipe shall be installed in a manner that does not cause upheaval, settlement, cracking, and movement or distortion of surface features. Any damages caused by the Contractor’s operations shall be corrected by the Contractor at no cost to the Water Department.

(6) In the event that unexpected subsurface conditions impeding drilling operations are encountered, the procedure shall be stopped and not continued until the Engineer has been consulted. The pipe may be installed full of water.

(7) If the final grade of the finished bore is not satisfactory to the Engineer or any other jurisdictional entity, the pipe shall be abandoned, full pressure grouted in place in accordance with the jurisdictional authority, and an alternate installation shall be made. The abandoned pipe shall be properly shown on “as-built” drawings to be submitted following conclusion of the construction work.

(8) The Engineer shall inspect the installed pipe ends for roundness and/or damage. Evidence of over-pulling or significant surface scratching shall be brought to the attention of the Engineer. Deformations of more than 10 percent may be grounds to abandon the bore and have the Contractor re-drill another line at no additional cost to the Water Department.

g) Butt Fusion Procedure

(1) Fusion welds shall be performed by an experienced technician who has been properly trained to meet the pipe manufacturer’s procedures. All welds shall meet the pipe manufacturer’s recommendations.

(2) As the pipe ends are melted against the heater during the heating period, the molten plastic will swell and form melt beads around the pipe ends. The melt beads shall be the same size on

both pipe ends, and uniformly sized all the way around.

(3) After melting has been completed, the ends shall be separated just enough to remove the heater, observed for uniformity of the beads and quickly (within three seconds) brought together with the recommended pressure.

(4) If melted plastic sticks to heater, the two ends may not be joined. The ends shall be allowed to cool and the procedure started over.

(5) Excess pressures shall not be used as this will squeeze too much melt out of the fusion area and result in a weakened joint.

h) Connecting Two Adjoining Sections of Directionally Bored Pipe

(1) If the overall length of the required utility installation cannot be safely pulled using one directional bore, then the Contractor shall be required to make more than one pull to accomplish the installation.

(2) Where two adjacent pulls meet, the Contractor shall dig a pit and join the two sections together at the elevation of the two segments as if it were a continuous pull-in. Space permitting, the Contractor may butt fuse the sections of pipe together. If space is not adequate to permit butt fusion, the two sections of HDPE shall be joined together using an electrofusion solid coupling. This coupling shall be installed in conformance with the coupling manufacturer's recommendations and these documents.

(3) The Contractor may perform a preliminary pressure test on the completed string of pipe prior to installation. A pressure test shall be required on the completed directional bore prior to final acceptance.

i) Disinfection

Disinfection of directionally drilled water mains shall be in accordance with AWWA C651, and as outlined in these specifications.

j) Post-Construction

The Contractor shall be considered as having completed the requirements of the directional bore when he has successfully completed the work to the satisfaction of the Engineer.

k) As-Builts

When the directional bore is completed, the Contractor shall interpret the information from the data log sheets and produce marked-up as built drawings. The redline drawings and as-built will reflect horizontal offset from the baseline and depth of cover, every 50 feet and at all changes in direction, whichever is less. All fittings, valves, hydrants, meters and meter services will also be referenced and shown. This document, along with the tracking log sheets, will be provided to the Engineer for his

review and approval.

9. Directional Drilled Pipeline Testing

The Department will require the Contractor to perform the required tests to ensure that all pipe installed including service lines meets the Department's standards.

(1) Flushing. The pipe shall be thoroughly flushed prior to testing, with flow velocities sufficient to flush any foreign material from the pipeline. Flushing shall be continued until the discharge appears clean; however, the minimum flushing duration shall be no less than three changes of tested pipeline volume.

(2) Filling. The pipeline shall be filled slowly. Air valves at high points shall be opened to allow air to escape as the water level increases inside the pipeline. If permanent air valves are not required at all high points, the Contractor shall install temporary valves at these points to expel air during filling. Loosening flanges or connections to bleed air from the system is prohibited. A typical maximum filling rate for a pipe system with 2-inch air valves is 2 ft³/sec.

(3) Hydrostatic (Pressure) Testing

All newly laid ductile iron pipe (including fittings and valves) shall be pressure tested in accordance with AWWA Standard C600 and these documents where applicable. All newly laid PVC pipe (including fittings and valves) shall be pressure tested in accordance with AWWA Standard C605 and these documents where applicable. HDPE pipe shall be tested in accordance with AWWA Manual M55, and ASTM F2164-02.

It should be note that ASTM F2164 is a field leak testing procedure, not a pressure test of the system. In PE piping systems, field pressure tests cannot be used to determine system pressure capacity, due to expansion of the material. Under no circumstances should the total time for pressurization and time at test pressure exceed eight hours at 1.5 times the system pressure rating. If the test is not completed within this total time, the test section should be depressurized and allowed to “relax” for at least eight hours before starting the next testing sequence.

The Contractor shall provide all necessary equipment and instrumentation (pressure gauges, volume gauges, hoses pumps, test pipe, test fittings, etc.) required for flushing and testing of the piping systems. Pressure gauges shall be marked in graduated increments that do not exceed 2 pounds per square inch. Gauges used to measure the volume of water necessary to raise post-test line pressure back to the highest pressure achieved during the test duration will be marked in graduated increments which do not exceed 5 ounces. If requested by the Engineer, the Contractor shall furnish to the Engineer certified test data for the pressure gauges and recorders used on hydrostatic equipment.

Water for test purposes will be supplied by the Department. At the option of the Engineer, flow meters and/or pressure gauges used on hydrostatic testing equipped with approved strip or round chart recorders shall be supplied by the Contractor. Tests shall be made in sections not to exceed 1/2 mile. Testing shall be conducted in the presence of and to the satisfaction of the Engineer as a condition precedent to the approval and acceptance of the system. Not less than 3-days of notice shall be given prior to start of such tests, and such testing shall not be scheduled until the Contractor has indicated that the test section is ready

for testing. The schedule and procedures for testing shall be determined by the Contractor and reviewed with the Engineer prior to testing.

If valves are installed on the directional drilled pipeline, test shall be made between valves to demonstrate the ability of the valve to sustain pressure. All piping systems shall be tested in accordance with these test methods in addition to any other tests required by local plumbing codes or building authorities.

The Contractor is warned that pressure testing against existing valves is done at his own risk. Failure of these valves to hold test pressure will not relieve the Contractor of the pressure testing.

Before conducting the test, the Contractor shall backfill all pipe and reaction blocking unless the Engineer directs certain joints or connections to be left uncovered. When reaction blocking is provided, the pressure test shall not be made until adequate curing time for the blocking has been allowed.

Before application of the test pressure, all air shall be expelled from the pipe. To accomplish this, taps will be made, if necessary, at points of highest elevation and afterward tightly stopped with tapered brass plugs, all at the Contractor's expense.

Pressurization (the initial expansion phase) of each HDPE pressure test section shall be at least 4-hours with a minimum test pressure in excess of 150 psi. Pressurization of PVC pipe shall be as required to flush the pipe of air and fill it with water. Contractor shall add make-up water as necessary to maintain maximum test pressure for 4-hours for HDPE, or to maintain pressure 2-hours to test PVC pipe. At no time shall the test or line pressure exceed 190 psi. If required by the Engineer, pump test equipment will be equipped with pressure relief valves pre-set to 190 psi. Each valved section of pipe shall be slowly filled with water and a pump shall be connected to the low point of the section being tested.

Throughout the duration of pressurizing HDPE pipe or testing PVC pipe, the Contractor is required to maintain a minimum pressure in excess of 150 psi in PVC pipe. The Contractor is advised that, should the test pressure fall to or below 150 psi any time during the 4-hour HDPE pressurization (or the 2-hour test, if PVC), the test will be considered invalid and a retest will be required.

At the end of the pressurization period, the Contractor will be required to pump the lines back up to the highest pressure obtained during the pressurization period, to begin the next phase of the pressure test - the test phase. For HDPE pipe, begin the test phase by reducing the test pressure by 10 psi, and monitor for 1 hour. Do not increase pressure or add makeup water. For PVC pipe, monitor for 2-hours, adding water as required to maintain the pressure to within +/-5 psi of the stabilized pipe pressure.

(2) Acceptance criteria.

- (a) HDPE: If no visual leakage is observed during the 1-hour test phase period, and pressure during the test phase remains steady (within 5% of the test phase pressure), a passing test is indicated.
- (b) PVC: installation is considered acceptable if the amount of water added during the 2-hour test phase to maintain pressure within +/-5 psi of the test pressure is less than L:

$$L = (SD(P^{0.5}))/148,000$$

Where: L = testing allowance (makeup water), in gal/hr.
 S = length of pipe tested, in feet
 D = nominal diameter of the pipe, in inches
 P = average test pressure during the hydrostatic test, in psi (gauge)

All exposed pipe, fittings, valves and joints shall be carefully examined for leaks. Any cracked or defective pipe, fittings, valves or other appurtenances discovered as a consequence of the pressure test shall be removed and replaced with acceptable material. All leaking or defective joints shall be repaired, corrected or replaced. After all necessary replacements and corrections have been made, the test shall be repeated to the satisfaction of the Engineer.

If the pipeline fails the test twice, the Contractor shall be required to retest the pipeline and provide the Department certification by a Professional Engineer registered in the State of Florida that the pipeline has passed the test in accordance with these standards.

T2.06 Casing Installation

When required for Work Order Work, casing installation shall be performed by jacking and boring under highways and railroads where shown on the plans. The casing pipe size, thickness, length, location and detail shall be as indicated and specified hereinafter. The work shall be performed by a qualified contractor experienced and regularly engaged in this type of work. All necessary materials, equipment, labor and traffic protection devices shall be on the job site before starting the work.

The Contractor shall strictly adhere to Florida Department of Transportation Utility Accommodation Manual, Hillsborough County Utility Accommodation Guide, CSX Transportation, Inc./Seaboard System Railroad Standard Specifications for Pipelines, AASHTO Standards and requirements of any other agency, whether public or private, having jurisdiction over the highway/railroad property concerned. The Contractor is advised that the requirements of the jurisdictional authority may limit start and stop days of the week as well as times of the day. Requirements may be established either verbally from an on-site representative, may be in the form of a written notice or permit, or may be transmitted through the Department. No construction or mobilization shall be started until the necessary permits have been obtained, a copy of the permit is at the job site, and proper notice and approval for construction have been obtained from the Department.

Casing pipe shall be welded steel pipe having minimum sizes and thickness as shown in the Standard Details contained within this document. The steel shall meet the requirements of ASTM A139, Grade A. The Contractor may use a welded steel casing pipe of a larger diameter if approved by the Department.

Only new pipe shall be used and all surfaces shall be smooth and uniform without bulges, dents, or warping. Finished lengths of pipe shall have beveled cut ends to facilitate proper, full depth welding of transverse joints. The casing may require bituminous coating if so dictated by the agency having jurisdiction over the jacking and boring site.

Prior to ordering equipment and materials for the jacking and boring operation, the Contractor shall get approval from the Department of his jacking equipment. Hydraulic jacks shall be used in the jacking operation and extreme care shall be taken to hold to exact line and grade. Excavation at the heading shall be advanced not more than one foot ahead of the casing pipe and may be done manually with an auger. Reaction

blocks shall be utilized and adequately designed to carry the thrust of the jacks to the soil without excessive soil deflection and in such a manner as to avoid any disturbance of adjacent structures or utilities. Adequate protection railings shall be provided at the top of the pit at all times.

The jacking pit shall be of adequate length to provide room for the jacking frame, the jacking head, the reaction blocks, the jacking auger rig, and the jacking pipe. The pit shall be sufficiently wide to allow ample working space on each side of the jacking frame. The depth of the pit shall be such that the invert of the pipe when placed on the guide frame will be at the elevation desired for the completed line. The pit shall be tightly sheeted where necessary and kept dry at all times. The jacking frame shall be designed so that it applies a uniform pressure over the entire pipe wall area of the pipe to be jacked.

Extreme care shall be taken to insure that the casing is installed to accurate line and grade; maximum acceptable error in any direction from the design grade and alignment shall be 1/8-inch per foot or as directed by the Department.

Upon completion, the Contractor shall obtain and furnish to the Department, a written release from the governing agency indicating satisfactory completion of the crossing.

T2.07 Fittings

Fittings shall be handled with care to avoid damage. All fittings shall be loaded and unloaded by lifting, and under no circumstances shall fittings be dropped, skidded, or rolled. Fittings shall not, under any circumstances, be placed against pipe or other fittings in such a manner that damage could result. Slings, hooks, or tongs used for lifting shall be padded in such a manner as to prevent damage or exterior surface or interior lining of fittings. If any part of the fittings' coating or lining is damaged by the Contractor, the repair or replacement shall be made by the Contractor in a manner satisfactory to the Engineer before installing. Fittings shall also be stored at all times in a safe manner to prevent damage and kept free of dirt, mud, or other foreign matter. All fitting gaskets shall be stored and placed in a cool location out of direct sunlight and out of contact with petroleum products. All gaskets shall be used on a first-in, first-out basis. Adequate precautions shall be taken to prevent the separation of joints at bends, tees, and plugged ends.

Details of design, construction, applications, installations, and number of joints necessary for the restraint of a given thrust shall be as specified herein, as shown on the Standard Details or as indicated on the plans. Under no circumstances shall gray iron pipe be used at restrained joints. Ductile iron pipe will be used unless otherwise specified by the Department.

Where reaction or thrust blocking is required, it shall be of concrete meeting the following design criteria:

- Compressive Strength - 3,000 PSI
90% after 7 days
110% after 28 days
- % Air Entrainment - 5.0%
- Water/Cement Ratio - 265 lb. Water/1 CY Concrete
- Maximum Aggregate Size - 1½"
- Slump - 3" - 4"

Blocking shall be placed between undisturbed earth and the fitting to be anchored where firm support can be obtained. The area of bearing on the pipe and on the ground in each instance shall be that shown on the plans,

the Standard Detail or as directed by the Engineer. The fittings shall be polyethylene encased in a manner acceptable to the Engineer prior to blocking. The blocking shall, unless otherwise shown or directed, be so placed that the pipe and fitting joints will be accessible for repair. If the soil does not provide firm support, then suitable tie rods, bridles, clamps and accessories as specified by the pipe manufacturer to brace the fitting properly shall be provided.

Pre-cast thrust blocks may be used in lieu of poured-in-place blocks on 8-inch and smaller ductile iron water mains only. This type of block must be manufactured in accordance with these Technical Specifications. Size and bearing area of blocks will be as shown in the standard details or as determined by the Department. The Department has the authority to reject any damaged block or any block considered to be of questionable quality. Placement will be in accordance with standard procedures for restraining thrust. Earth behind such blocks will be either undisturbed or compacted to a minimum of 95% (Modified Proctor) density.

Tie rods and pipe clamps when allowed by the Department must be of adequate strength to prevent movement or other suitable means may be used as allowed by the Department. Steel rods, clamps, and washers shall be rustproof treated with bituminous material and polyethylene encased.

T2.08 Valves

Valves shall be handled with care to avoid damage. All valves shall be loaded and unloaded by lifting, and under no circumstances shall be dropped, skidded, or rolled. Valves shall not be placed, under any circumstances, against pipe, other valves or other fittings in such a manner that damage could result. Slings, hooks, or tongs used for lifting shall be padded in such a manner as to prevent damage. If any part of the valves' coating and lining is damaged by the Contractor, the repair and replacement shall be made by the Contractor at his expense in manner satisfactory to the Engineer before installing. Valves shall also be stored at all times in a safe manner to prevent damage and kept free of dirt, mud, or other foreign matter. All valve gaskets shall be stored and placed in a cool location out of direct sunlight and out of contact with petroleum products. All gaskets shall be used on a first-in, first-out basis.

Valves shall be set and joined to new pipe in a manner heretofore specified for cleaning, laying, and joining pipe. Valves shall be installed such that the operating nut is plumb, and its top is less than 48-inches from finish grade at the valve. Valves shall be furnished with extension stems if operating nut is greater than 48-inches deep, to bring the operating nut to within 24-inches of the top of the valve box (see Detail 3.05). Connection to the valve shall be with a wrench nut coupling and a set screw(s) to secure the coupling to the valve's operating nut. The coupling and square nut wrench shall be welded to the extension stem. Rock guard and centering plate are required. Extension stems shall be equal to or better than ProSelect Gate Valve Extension – with Centering Plate, or Trumbull Gate Valve Extension Stems, Style B.

Cast iron valve boxes shall be firmly supported and maintained centered and plumb over the operating nut of the valve by the Contractor, box cover flush with the surface of the finished pavement, or at such other levels as may be directed. Valve boxes shall have 6-inch thick wire mesh reinforced concrete pads poured around the top section of the valve box. The pad shall be 24-inches square and shall be centered on the valve box. All Department valve covers shall be painted safety blue as prescribed by the American Public Works Association (APWA) uniform color code for utility systems. Bronze valve identification disks (3" OD x 1/8" thick) are required for all valve installations in accordance with Detail 3.06.

The valve and valve box shall be installed so Department personnel can insert a valve key through the valve

box and completely open and close the valve. This test will be accomplished before final acceptance of the valve and box into the water system. Approved Curb Stop Boxes, if required to house tracer wires, and less than 3.25" O.D., shall be installed in the concrete valve box pad, centered between the valve box and a corner of the pad. Approved Curb Stop Boxes with >3.25" O.D. shall be installed in a 12-inch square, 6-inch thick wire mesh reinforced concrete pad poured around the top section of the box.

T2.09 Taps

All material supplied shall be disinfected in accordance with Department standards.

After the tapping sleeve and valve have been installed and before the tap is made, the sleeve shall be tested to ensure a watertight joint. A test plug shall be provided in the sleeve and after the sleeve has been installed, it will be filled with water and the pressure increased to between 150 psi and 190 psi. All leaking joints shall be repaired to the satisfaction of the Engineer at the Contractor's expense.

All tapping sleeves shall be wrapped and sealed with polyethylene encasement material in a manner acceptable to the Engineer.

T2.10 Hydrants

Fire hydrants shall be handled so as to avoid any damage at all times. Hydrants shall be located in a manner to provide complete accessibility and in such a manner that the possibility of damage from vehicles or injury to pedestrians will be minimized. Fire hydrants in FDOT rights-of-way shall conform to FDOT clear zone requirements. Unless otherwise directed, the setting of any hydrant shall be as described in these Technical Specifications. All fire hydrants shall be thoroughly cleaned of dirt or foreign material before installation. All hydrants shall stand plumb and shall have their pumper nozzle perpendicular to the curb. The top of flange elevation shall be finished grade plus 4 inches. Standard depth of bury shall be 3 to 5 feet. Each hydrant shall be connected to the water main with a 6-inch branch controlled by an independent 6-inch resilient seat gate valve hydrant shut-off valve. Per the Florida Fire Prevention Code, NFPA 1:18.3.4.1, clearances of seven and one-half feet (7-1/2') in front of and to the sides of the fire hydrant are required, with four feet (4') clearance required to the rear of the hydrant.

All fire hydrant leads shall be made of ductile iron pipe. All fire hydrant tees shall be made of ductile iron. All hydrants shall be anchored by restrained fittings as specified in these Technical Specifications and as shown in the Standard Details.

All fire hydrants shall be painted with a high-grade enamel, Federal Safety Yellow (OSHA approved), above the ground line.

All hydrant sets shall include the installation of a concrete thrust collar around the barrel of the hydrant 8 inches below the ground line.

Upon completion of installation and passing all required tests, the Contractor shall paint the bonnet of the hydrant OSHA green.

T2.11 Meter and Fire Service Connections

Any water meter and fire service connection made to new water distribution mains shall be at locations called for in the plans, in meter set cards, or as otherwise directed by the Department. No meter or fire service connections are to be installed outside public right-of-way limits unless easements have been provided or as directed by the Engineer. Any trenching, excavation, backfilling, cutting, tapping necessary to install meter and fire service connections and such incidental work associated with the installation of meter and fire service system shall be performed in strict accordance with these specifications or as directed by the Engineer. Meters and double detector check valves shall be handled so as to avoid any damage at all times.

T 2.12 LOCATING (TRACER) WIRE

All plastic piping (and 16-in. and larger ductile iron pipe) shall be installed with two continuous, insulated, blue coated, solid UF (Underground Feeder per National Electric Code Article 339) copper tracer wires for water main location purposes by means of an electronic line tracer.

The wires must be installed along the entire length of the pipe. Wire shall be continuous double-strands attached to the top of the pipe with duct tape, and shall be looped around each bell.

Wire ends shall terminate in curb stop boxes located in concrete valve box pads per Detail 3.02 – Valve Box and Pad Installation, or in isolated 12” x 12” x 6” wire reinforced concrete pads per the same Detail.

Tracer wire for long-side meter service lines (which require service line tubing encased inside of a sleeve) shall be taped to the top of the tubing inside the sleeve.

Upon completion of the installation, the Contractor shall demonstrate to the Water Department that the wire is continuous and unbroken through the entire run of the pipe by providing full signal conductivity (including splices) when energizing for the entire run, in the presence of the Engineer. If the wire is broken, the Contractor shall repair or replace it. No payment will be made for pipe installed until the tracer wire passes continuity testing.

Tracer wire for direct bury installations shall be approved insulated copper clad steel (CCS) wire such as Copperhead High Strength Tracer Wire, or Pro-Trace HF-CCS PE45 Tracer Wire. Wire insulation shall be minimum 30 mil high-density, high molecular weight polyethylene (HDPE) colored to meet the APWA color code standard for identification of buried utilities. Conductor must be at 21% minimum conductivity for locate purposes, and be able to withstand a minimum 450 lb. break load. Wire splices must be with wire connectors suitable for buried service (be corrosion- and moisture-proof) such as the DBR Kit (by 3M), Snakebite (by Copperhead Industries), or approved equal.

Sizes (gauges) for direct bury pipe tracer wire shall be as follows:

16-in. and larger ductile iron pipe: **10 AWG**

PVC pipe: **12 AWG**

Long-side meter service line (direct bury and directional drilled): **12 AWG**

Tracer wire for directional drilled or bored-in pipe shall be approved insulated copper clad steel wire such as Copperhead SoloShot™ (**10 AWG**) extra-high-strength copper-clad steel (EHS-CCS), insulated with 45 mil, high-density, high molecular weight polyethylene (HDPE), and rated for direct burial use at 30 volts minimum. Conductor must be at 21% minimum conductivity for locate purposes, and be able to withstand a minimum 1150 lb. break load.

Tracer wire for Pipe Bursting shall be approved insulated copper clad steel wire such as Copperhead Industries SoloShot™ Xtreme, 7x7 stranded Copper Clad Steel, insulated with a 50 mil, high-density, high molecular weight polyethylene (HDPE) insulation, and rated for direct burial use at 30 volts minimum. Conductor must be at 21% minimum conductivity for locate purposes, and be able to withstand a minimum 4700 lb. break load.

For directional drilled and pipe bursting installations, a 1-in. conduit may be pulled back with the locating wires, to ease installation and to prevent the wires from breaking.

T3.00 TESTING

The Department will require the Contractor to perform the required tests to ensure that all pipe installed including service lines meets the Department's standards. The required tests are as follows:

T3.01 Hydrostatic Testing

1. Pressure Testing

All newly laid pipe, including fittings, valves and service lines shall be pressure tested in accordance with AWWA Standard C600 and these documents where applicable.

The Contractor shall provide all necessary equipment and instrumentation (pressure gauges, volume gauges, hoses pumps, test pipe, test fittings, etc.) required for flushing and testing of the piping systems. Pressure gauges shall be marked in graduated increments that do not exceed 2 lbs. per square inch. Gauges used to measure the volume of water necessary to raise post-test line pressure back to the highest pressure achieved during the test duration will be marked in graduated increments which do not exceed 5 ounces. If requested by the Engineer, the Contractor shall furnish to the Engineer certified test data for the pressure gauges and recorders used on hydrostatic equipment.

Water for test purposes will be supplied by the Department. At the option of the Engineer, flow meters and/or pressure gauges used on hydrostatic testing equipped with approved strip or round chart recorders shall be supplied by the Contractor. Tests shall be made in sections not to exceed 1/2 mile. Testing shall be conducted in the presence of and to the satisfaction of the Engineer as a condition precedent to the approval and acceptance of the system. Not less than 3 days of notice shall be given prior to start of such tests, and such testing shall not be scheduled until preliminary testing by the Contractor has indicated that the test section is ready for testing. The schedule and procedures for testing shall be determined by the Contractor and reviewed with the Engineer prior to testing.

The duration of each pressure test shall be at least 2 hours with a minimum test pressure in excess of 150 psi. At no time shall the test or line pressure exceed 190 psi. If required by the Engineer, pump test equipment will be equipped with pressure relief valves pre-set to 190 psi. Each valved section of pipe shall be slowly filled with water and a pump shall be connected to the low point of the section being tested.

Before conducting the test, the Contractor shall backfill all pipe and reaction blocking unless the Engineer directs certain joints or connections to be left uncovered. When reaction blocking is provided, the pressure test shall not be made until adequate curing time for the blocking has been allowed.

Before application of the test pressure, all air shall be expelled from the pipe. To accomplish this, taps will be made, if necessary, at points of highest elevation and afterward tightly stopped with tapered brass plugs, all at the Contractor's expense.

At the end of the 2-hour test period, the Contractor will be required to pump the lines back up to the highest pressure obtained during the duration of the test period.

Pressure tests shall be made between valves to demonstrate the ability of the valve to sustain pressure. All piping systems shall be tested in accordance with these test methods in addition to any other tests required by local plumbing codes or building authorities.

Throughout the duration of the test, the Contractor is required to maintain a minimum pressure in excess of 150 psi. The Contractor is advised that, should the test pressure fall to or below 150 psi any time during the 2-hour test, the test will be considered invalid and a retest will be required. Therefore, it is advised that the Contractor should pump water into the line as the test pressure approaches 150 psi.

The Contractor is warned that pressure testing against existing valves is done at his own risk. Failure of these valves to hold test pressure will not relieve the Contractor of the pressure testing.

All exposed pipe, fittings, valves and joints shall be carefully examined for leaks. Any cracked or defective pipe, fittings, valves or other appurtenances discovered as a consequence of the pressure test shall be removed and replaced with acceptable material. All leaking or defective joints shall be repaired, corrected or replaced. After all necessary replacements and corrections have been made, the test shall be repeated to the satisfaction of the Engineer.

If the pipeline fails the pressure test twice, then the Contractor shall be required to retest the pipeline and provide to the Department certification by a Professional Engineer registered in the State of Florida, that the pipeline has passed the test in accordance with these standards prior to the Water Department scheduling and witnessing the pressure test.

2. Leakage Tests for Pipelines

Concurrently with pressure testing, pipelines shall be subjected to leakage tests.

Leakage measurements shall not be started until a constant test pressure has been established in excess of 150 psi.

The duration of each leakage test shall be at least 2 hours and the test pressure shall be as specified for the pressure tests. Leakage is defined as the quantity of water that must be supplied into the pipeline or section thereof to maintain the established test pressure after the air in the pipeline has been expelled and the pipe filled with water plus that volume of water required at the conclusion of the test to bring the line pressure back up to the highest pressure obtained during the duration of the test period.

The maximum allowable leakage shall not exceed the number of gallons per hour (gph) as determined by the following formula:

$$L = (SD \times \sqrt{P}) / 148,000$$

where,

L - allowable leakage, gph

S - length of pipeline tested, feet

D - nominal diameter of the pipe, inches

P - average test pressure during the leakage test, psi gage

When leakage exceeds the allowable limit, the defective pipe or joints shall be located and repaired. All visible leaks are to be repaired regardless of the amount of leakage. If the defective portions cannot be located, the Contractor shall remove and reconstruct as much of the work as is necessary until the leakage is within the allowable limits. Such corrective work or damages to other parts of the work as a result of such work shall be at the Contractor's expense.

Leakage detection at mechanical joints shall be stopped by tightening the gland (not to exceed required torque) and leaking slip joints shall be cut out and entirely replaced or if permission is given by the Engineer, it may be repaired by a suitable clamp. Any split, cracked or defective pipe, fittings, valves, or hydrants discovered as a result of this test shall be removed and replaced by the Contractor with sound material and then test shall be repeated.

If the pipeline fails the test twice, the Contractor shall be required to retest the pipeline and provide the Department certification by a Professional Engineer registered in the State of Florida that the pipeline has passed the test in accordance with these standards.

T3.02 Disinfection

The Contractor shall disinfect the water mains in accordance with the applicable section of the latest AWWA Specification C651, as summarized below. The Contractor, if directed, shall use the method specified by the Engineer.

Method of Chlorination

1. Slug Method

The slug method consists of: a) Completely filling the main in order to remove air pockets, b) flushing the main with a velocity of not less than 2.5 feet per second (fps) in order to remove particles, c) at a point not more than 10 feet downstream of the water source flushing the new main; chlorine is to be continuously injected for a sufficient period to develop a solid column or "slug" of chlorinated water, d) the slug of chlorinated water is to move through the main exposing all interior surfaces to a chlorine concentration of approximately 100 mg/L for at least a 3 hour period.

2. Continuous Feed Method

The continuous feed method consists of a) completely filling the main to remove air pockets, b) flushing the main with a velocity not less than 2.5 fps, c) at a point not more than 10 feet downstream of the water source flushing the new main; chlorine is to be injected in the new main at a constant rate sufficient to establish a 25 mg/L chlorine concentration throughout the main, d) Note table for amount of sufficient chlorine required for

each 100 foot section of pipe of various diameters.

<u>Pipe Diameter</u>	<u>100% Chlorine (lb)</u>	<u>1% Chlorine Solution (gal)</u>
4	0.013	0.16
6	0.030	0.36
8	0.054	0.65

The chlorinated water shall be retained in the main for at least 24 hours and have a residual of not less than 10 mg/L free chlorine prior to flushing.

3. Testing

Upon completion of the hydrostatic test and disinfection, the Contractor shall contact the Department's Construction Section requesting a bacteria test. The Contractor shall install sample taps on the new main and at the end of each new branch of the piping system. The Contractor shall flush the chlorinated disinfection water from the piping system until a free chlorine residual of 1 to 1.5 mg/L is maintained. The Engineer will pull a water sample on 2 consecutive days allowing 24 hours for each sample to be processed.

The contractor shall coordinate the scheduling of the sampling procedure a minimum of one-week in advance of wanting the sample to be pulled. Due to the varying workload, the sample will be scheduled and pulled as the schedule permits. All failed samples, or samples that are not ready at the time of collection, will be charged to the contractor at the current rate it costs the Department per sample.

Due to the requirements from the FDEP, the contractor may be required to remobilize to the job site thirty to forty-five days after the samples have been cleared to perform necessary meter transfers and/or cut and plugs.

Samples for bacterial analysis will be taken and analyzed by the Department. The sampling process may only begin on Mondays or Wednesdays. Two consecutive approved samples, taken 24 hours apart, will be required. Those samples will be pulled by the Water Department 24 hours apart. If the first sample is taken on Monday, the second sample must be taken on Tuesday. If the first sample is taken on Wednesday, the second sample will be taken on Thursday. No samples will be taken on Friday and the sampling process will not begin on Tuesday or Thursday. All drilling and tapping equipment shall be sterilized as directed by the Engineer.

After completing the testing and sterilizing and regardless of ground conditions, all sample taps and corporation stops shall be removed from the pipe and replaced with tapered brass plugs.

T4.00 RESTORATION

T4.01 Waste Material Disposal

The Contractor shall remove and dispose of all debris and excess spoil resulting from clearing, demolition and excavation operations. Natural waterways or bodies water shall not be used for disposal or debris.

All debris shall be disposed of at a site approved and permitted by the State for such disposal. Clean spoil

may be disposed on private property only with written authorization of the property owner.

Burning of brush or debris may be permitted, if allowed by the City, subject to the Contractor's securing permits and providing such fire watch and notification of local fire companies as may be required by local law or ordinance. Such permits, however, shall not relieve the Contractor of his responsibilities or liabilities with regard to protecting public health or properties.

T4.02 Repair and Resurfacing

Where street paving, driveways, sidewalks or curb and gutter is disturbed, restoration shall be made to a condition at least equal to the original. All materials used for restoration shall conform to standard requirements of that particular agency responsible for roadway maintenance where construction takes place. All restoration work shall also meet the requirements of both the permitting agency as well as the City. The Contractor shall determine, to his own satisfaction, any requirements and procedures, other than those set forth herein, which may affect the type, quality and method of carrying out the restoration to the satisfaction of the Department of areas to be restored.

Base material shall be of the type removed or of equal or greater structural strength as determined by the Engineer. Existing base material from the excavation shall not be reused as base material, but may be used as a stabilizer, or for trench backfill, after removal of existing asphalt, unless it is determined by the Engineer to be unsuitable.

Edges of pavement shall be mechanically sawed to provide a neat, straight edge to the width shown on the plans, or greater if necessary, prior to replacement. Base material shall be placed to the depths required by permitting agency and thoroughly compacted to the density required by the Department or to the standard of the governing permitting agency.

The Contractor shall pay careful attention to the proper reconstruction of the pavement adjacent to the gutters and at street intersections to obtain satisfactory drainage to inlets from the intersecting streets.

Pavement replacement shall be with the same materials as removed and installation methods and procedures shall comply with the appropriate procedures established by the FDOT Standards Specifications or the appropriate permitting agency.

In the absence of governing agency requirements, where asphaltic concrete overlays are performed, the overlays shall be one inch (1") thick over the pipe trench area as directed by the Department so as to provide a smooth transition between the existing pavement and the overlay pavement. In the event that the contractor maintains his disturbed area within the maximum pay limits but the jurisdictional authority requires milling and overlaying in excess of the maximum pay limits, the contractor will be paid for the additional milling and overlaying at the appropriate contract unit prices.

Permanent pavement replacement shall not commence until acceptable to the Engineer. Until such replacement is completed, the Contractor shall maintain all trenches and disturbed areas, providing additional base materials as is necessary to maintain smooth transition of the areas by vehicular traffic and providing dust control as necessary.

T4.03 Pavement Marking

Where shown or required for repaired/replaced pavement, pavement marking shall be painted with thermoplastic markings.

Thermoplastic compound sealing primer and glass spheres shall meet the requirements of FDOT Standard Specifications, Sections 711 and 971, or the requirements of the governing permitting agency.

Pavement marking of repairs/replacements shall match the previously existing pavement where applicable. Where markings are required other than replacement of previously existing markings, the Contractor shall follow the requirements of the U.S. Department of Transportation, Manual of Uniform Traffic Control devices for streets and Highways. Application of thermoplastic markings shall comply with FDOT Standard Specifications, Section 711, or the requirements of the governing permitting agency. Reflective pavement markers (RPMs) shall be installed to match the pattern in place prior to the start of construction.

T4.04 Street Signs, Traffic Signs and Informational Signs

Removal and relocation of all street or traffic signs shall be approved through the appropriate permitting agency.

The Contractor will furnish and install project informational signs as indicated in the contract documents and as directed by the Engineer. The Contractor will remove the sign at the conclusion of the project. Compensation will be in conformance with the appropriate pay item(s).

T4.05 Seeding

All areas designated to be seeded by the Engineer shall be according to installation procedures and materials outlined herein.

Materials for top soils and seeding, including fertilization, shall comply with the applicable requirements of FDOT Standard Specifications, Sections 570 and 981, or the governing permitting agency.

Areas designed to be seeded shall first be fine graded to match the surrounding areas and shall be sown only where the soil is moist and in proper conditions to induce growth. Seeding operations shall not be undertaken when wind velocities exceed 15 mph or the soil is unduly wet or otherwise not in a tillable condition. Grass seed shall be in accordance with FDOT Standard Specifications, Section 570 or shall be of a quality acceptable to the Department. The Contractor shall properly water and otherwise maintain all seeded and mulched areas until final acceptance by the Engineer. Any areas that fail to show a "catch" or uniform stand shall be reseeded and such reseeding shall be repeated, at no additional cost to the Department, until final acceptance. Procedures for top soils and seeding, including fertilization, shall comply with the applicable requirements of FDOT Standard Specifications, Section 570, or the governing permitting agency.

T4.06 Sodding

All areas designated by the Engineer to be sodded shall be sodded according to installation procedures and materials outlined herein.

Sod shall be of the same type as the surrounding grassed areas (unless specified otherwise by the Department),

be free of weeds, and have well matted roots. The sod shall be live, fresh, and uninjured at the time of placing. Materials for sodding shall meet the applicable requirements of Sections 575 and 981 of the FDOT Standard Specifications, or the requirements of the governing permitting agency. Except as required to match surrounding grassed areas, sod may be St. Augustine, Bahia, or other varieties as selected by the Department.

Areas designated to be sodded shall first be fine graded to match surrounding areas and scarified or loosen to a suitable depth. Sod shall be placed as soon as possible after being dug and shall be shaded and kept moist from the time it is dug until it is planted. Methods for sodding shall meet the applicable requirements of Section 575 of the FDOT Standard Specifications, or the governing permitting agency.

T4.07 PAVEMENT/RIGHT OF WAY RESTORATION REQUIREMENTS – Rev. 2009

Pavement Options:

PAVEMENT *(Classification)	BASE MATERIAL (Section 1-2)	CONCRETE (Section 1-3)	ASPHALT SURFACE (Section 1-4)	FULL DEPTH ASPHALT (Section 1-5)
A	6”	4”	1”	5”
I	8”	6”	2”	7”
II	12”	8”	3”	10”

***Classification:**

Class A: Alleyways, Residential and Low Volume Commercial Driveways

Class I: 2-Lane Residential Streets and High Volume Commercial Driveways

Class II: Multi-Lane or High Volume 2-Lane Streets (most depicted by centerline markings)

Notes:

- 1) If existing roadway is stabilized, increase base material thickness by 50%
- 2) If original pavement exceeds max. 3” match the existing asphalt thickness
- 3) Minimum 4” of shell marl, crush concrete, or asphalt millings placed in unimproved (dirt) trafficked right-of-way
- 4) Concrete shock pad required for any utility repaired/ installed less than 30” (needs C.O.T. Engineer approval)
- 5) Brick pavement shall be restored as specified in Section 1-6 Brick Replacement

SECTION 1 PAVEMENT RESTORATION SPECIFICATIONS

1.0 BACKFILL and SUBGRADE: Replace and compact clean sub-grade material classified as A-1, A-2, A-3. Backfill shall be free of objectionable material (bricks, broken pavement, concrete, clay, muck, etc.). If flowable fill is used both mix and installation shall conform to FDOT Standard Specifications for Road and Bridge Construction (January 2000), Section 121-1 through 121-6.

1.1 Density Requirements: Material shall be compacted in lifts not to exceed 12-inches. Densities are required at alternative 1ft. lifts of vertical fill above excavation bottom of trench and for each prepared trench segment, not to exceed 200 lf. Density test is not to be taken through succeeding layers. The final subgrade density test shall be taken at elevation beneath Base Material or Full depth asphalt.

2.0 Density Specification: Shall meet 98% compaction of AASHTO T-180.

2.0 BASE MATERIAL: Approved by a City of Tampa D.P.W. Engineer and/or meeting the FDOT Standard Specifications for Road and Bridge Construction (latest version). Submittal may be requested by C.O.T.

2.1 Acceptable Materials: Limerock, Shell Marl, Crushed Concrete, Concrete (3000 min. PSI), and Asphalt Plant Mix.

2.2 Density Requirements: Place and compact in two lifts. Asphalt Plant Mix shall be compacted in accordance to Section 1-4. Densities are required for each trench segment at final grade, not to exceed 200'.

2.3 Density Specifications: Shall meet 98% compaction of AASHTO T-180.

3.0 CONCRETE: 3000 PSI minimum 28-day strength. Placed on compacted, moistened subgrade. Consolidate and cure. Do not load for 72 hours.

3.1 Concrete Specifications: Density test of subgrade may be required at the Inspector's discretion.

4.0 ASPHALT SURFACE: Sawcut all sides a minimum of 6-inches from replaced base. Paint with RC 70 (or equal) tack. Place and compact in lifts S-1 or S-3 type asphalt plant mix. The finished pavement is subject to inspection and approval by City of Tampa D.P.W. Engineer.

4.1 Density Requirements: Type S-1 lift to be 1¼" min. and 3" max. (if lift exceeds 2" compact with a drum roller type compactor). Type S-3 lift to be ¾" min. and 1½" max.

4.2 Density Specifications: Quality assurance testing of the asphalt may be required at the Inspector's discretion. (generally, 96% compaction of asphalt plant mix design bulk specific gravity)

5.0 FULL DEPTH ASPHALT: Same as requirements for Section 1-4 ASPHALT SURFACE

6.0 BRICK REPLACEMENT: Brick shall be re-laid according to Section 2 PROCEDURES. Place and grade 1½" of sand over base or concrete. Place brick uniformly, staggered with respect to the adjacent course. Any work area disturbing a street listed as a "Historical Street" shall be required to replace original brick. The contractor is responsible for safe storage of materials until such time the brick is re-laid.

6.1 Base Options:

A. Limerock and Shell Marl: shall meet Section 2 BASE MATERIAL specifications, requires brick joints to be sealed with Asphaltic Steep #7330 or Surebond 1300 Sealer.

B. Crush Concrete: shall meet Section 2 BASE MATERIAL specifications, requires brick joints to be sealed with 1:4 sand cement mixture (slurry or moistened to ensure that cement sets).

C. Concrete: shall meet Section 3 CONCRETE specifications, 4" of concrete is used as base material, requires brick joints to be sealed with 1:4 sand cement mixture (slurry or moistened to ensure that cement sets).

6.2 Density Requirements: Subgrade material shall meet Section 1 BACKFILL and SUBGRADE. Base material shall meet Section 2 BASE MATERIAL.

6.3 Density Specifications: Shall meet 98% compaction of AASHTO T-180.

SECTION 2 PAVEMENT RESTORATION PROCEDURES

GENERAL:

The Contractor shall contact the City's Lab 24-hours in advance to coordinate specific testing services necessary to meet or satisfy the contract specifications, or as directed by the Department's Engineer.

The Foreman on each project shall maintain on-site copies of the approved Department of Public Works "Application and Permit for Construction and Maintenance Operations within Public Rights of Way, including plans, drawings, and the Pavement Restoration Requirements – (2012 or latest issuance of Permit).

Copies of all applicable material delivery tickets and copies of all test results not taken by D.P.W. Materials Testing and Inspections, shall be forwarded to D.P.W. Technical Services at 3806 26 Ave East, Tampa, Fla. 33605. Fax number (813)-622-1956.

EXCAVATION:

Utility installations shall be placed a minimum of 30" below grade. If, because of utility conflicts or unusual conditions, the 30" minimum depth requirement cannot be maintained, special authorization may be granted for installation at a lesser depth. Installations shall maintain the 30" depth, unless special authorization is granted in writing, by the D.P.W. Engineer.

All trench widths under pavement, including driveways, are to be a minimum of 18", to allow mechanical compaction of backfill and base. Density tests are required and restoration shall meet SECTION 1.

Where pavement and/or base are undermined, disturbed, or otherwise damaged, such areas shall be cut away and the pavement replacement work extended to correct such conditions.

Tunneling under driveways, sidewalks, curbing, retaining walls, and pavement shall not be allowed unless approved prior to work is given by C.O.T. Engineer.

When obstructions are encountered in driving or jacking, pipe shall be cut off, left in place, and filled with a flowable fill type grout to prevent the formation of voids.

Edges of jacking pits, directional bore pits, exit pits, trenches, etc. shall be a minimum distance, equal to the depth of the pit excavation, from any pavement, curbs, sidewalks, or other structures. If this distance cannot be maintained, backfill shall be compacted in lifts not to exceed 12" and density tests taken as outlined in SECTION 1.

Ditches shall be restored promptly to prevent the formation of sediment in the existing drainage system. Erosion control shall be enforced. The existing ditch grade and cross section profile shall be maintained. The City will require sodding, sprigging, or seeding and mulching to restore stable cover of vegetation on ditch banks, shoulders, and other areas disturbed by construction. Vegetation restoration will be kept moist and maintained until well established. Staking of sod will be required if ditch slope exceeds 4:1.

Erosion control shall abide by Erosion Control Methods set forth in C.O.T: D.P.W. Standard Drawings where applicable

Lawn and landscaped areas shall be restored to original or better condition. Each situation may require individual attention and differing restoration procedures.

CONCRETE:

Concrete sidewalks, driveways or pavement affected by construction operations will be corrected by removing and replacing full panels. Cuts in concrete sidewalks or driveways shall be sawed in straight lines at panel joints and replaced to full panels.

Concrete replacement shall be a minimum thickness of 6" for driveways and 4" for sidewalks. Concrete and density requirements shall meet SECTION 3.

Concrete curb and gutter will be formed and placed as a single unit to conform to City of Tampa Standards.

Expansion joints shall be provided at no more than 50' intervals on curb and sidewalk replacement work.

Expansion material shall be used where new concrete meets existing. Sidewalks shall have tooled construction joints or sawed control joints at 5' intervals for 5' wide sidewalk and 6' intervals for 6' wide sidewalk

BRICK:

Brick pavement shall be re-laid as called for by the street replacement schedule and on a complete and accepted base with a sand cushion and only clean whole, sound brick shall be used.

Brick replacement consists of bringing the area to be repaved to a subgrade and base conforming to the required grade and cross section of uniform density ready to receive the brick. Material and density shall meet requirements of SECTION 6.

Any part of the subgrade and base area inaccessible to the mechanical compactor shall be compacted by hand or power tamping in a manner acceptable to the engineer.

The brick shall be laid in straight courses, flat on the prepared sand cushion, with the better side of face upward.

The brick shall be laid in close contact and the joints of each course shall be uniformly staggered with respect to adjacent courses. Whole brick shall be used except in starting or finishing a course and in fitting around manhole tops or structures. In general, not less than ¼ of brick shall be used in batting.

The joints shall be filled in accordance with SECTION 6.1 C.. The 1:4 sand/cement mixture shall be "soupy" and swept in with street brooms or may be dry mixed, swept in with street brooms, consolidated by vibratory methods, and sufficiently moistened to ensure that cement sets. Excess grout shall be removed from surface. Joint filler shall take place immediately to prevent joints from filling with foreign matter.

ASPHALT:

Asphalt pavement edges of cuts are to be sawed in straight lines parallel and perpendicular to pavement edges. One uniform parallel line for paving shall exist along edge outside trenchline. When the existing

asphalt is less than 3” thick, pavement shall be cut and removed for a minimum distance of 6” from edge of the trench.

Tack coat shall be applied to the surface of the pavement base and adjoining asphalt butted edge joint. *No* “feathering” of asphalt at the joint will be allowed. These areas are to be free of all loose material and foreign matter before applying tack coat.

Asphalt pavement installation shall be rolled in place in a controlled pattern with a mechanical compactor capable of sufficiently applying enough loads to meet density requirements in accordance with SECTION 4.

If an asphalt overlay is called for, a string line must be used while spreading the material, to obtain neat patches with straight edges. Where a cut is adjacent to or within 3’ of a previous patch, the pavement replacement and/or resurfacing shall be extended to include the previous patch.

Final surface restoration must be completed to the City’s standards and the City reserves the right to require the entire roadway surface width to be overlaid to lengths determined by the City.

Upon completion of the roadway surface, the contractor shall replace all damaged pavement markings per City standards.

TEMPORARY RESTORATION:

Temporary pavement surfaces and sub surface materials shall be restored conforming to all requirements regarding configuration, thickness, and density as detailed in SECTION 1. The pavement shall be temporary finished with a suitable grade of asphalt and sand to provide a temporary-wearing course and to eliminate a dust nuisance. Temporary pavement shall be restored with the proper **permanent** surface within specified time period stated in the legal Permit for Construction and Maintenance Operations within Public Rights of Way.

T4.08 VITRIFIED BRICK REPLACEMENT (REVISED 4/27/2009)

Subgrade:

This work consists of bringing the area to be repaved to a subgrade conforming to the required grade and cross section surface of uniform density ready to receive the base course. This is to be accomplished by excavating or backfilling as needed, shaping, and then rolling the entire area with an approved self-propelled tandem roller weighing not less than 8 tons. Shaping and rolling to continue until subgrade has been properly prepared and shows that no further compaction of any practical benefit would result from continued rolling. It shall be tested as to cross section, crown and elevation. After being properly prepared, it shall be so maintained until the base course is constructed. A completed subgrade shall be maintained sufficiently in advance of the base course operations to permit of proper control. Any part of the subgrade area inaccessible to the roller shall be thoroughly compacted by hand or power tamping in a manner acceptable to the engineer. Subgrade shall be minimum 12” and be compacted to 98% per AASHTO T-180.

Base:

This work consists of placing 10” of crushed concrete base material atop the prepared and accepted subgrade.

The base will be placed in at least two lifts. The 10" crushed concrete will have a minimum LBR of 100 and will be compacted to 98% per AASHTO T1-80.

Where a base is encountered under the brick pavement, it shall be restored to the same thickness with the approved crushed concrete material before relaying the brick pavement.

Sand Cushion:

A sand cushion shall be constructed on all completed bases for vitrified brick pavement. The sand cushion shall be sharp sand clean sand, free from clay, loam and other foreign matter, and shall be constructed to a uniform thickness of 1-inch upon the completed crushed concrete base. The sand cushion shall be prepared at least 25 feet in advance of laying the brick where possible. Care shall be exercised that the sand cushion is not disturbed or compacted until the bricks are in place and are ready for rolling.

Vitrified Brick Pavement:

Vitrified brick pavement shall be re-laid at locations called for by replacement schedule for street paving disturbed by construction operations, as shown on the plans. Vitrified brick pavement shall be re-laid on a completed base with a sand cushion and only clean whole, sound bricks shall be used. Acceptable brick removed from the disturbed areas removed by the contractor and/or removed from the City of Tampa stock pile, will be used for this repaving and shall not be hauled or moved by the contractor for use elsewhere unless directed by the engineer.

The brick shall be laid on straight courses, flat on the prepared sand cushion, with the better side of the face upward. The brick shall be laid in close contact and the joints of each course shall be uniformly staggered with respect to adjacent courses. Whole brick shall be used except in starting or finishing a course and in fitting brick pavement around manhole tops or other structures. In general, not less than one-fourth of brick shall be used in batting.

A timber straight edge shall be driven against each fourth course of brick by light blows with a sledge or maul to straighten the lines and eliminate appreciable space between the bricks.

The surfaces shall be swept clean and rolled with a tandem static roller weighing not less than 5 and no more than 8 tons in a manner to firmly embed each brick in the sand cushion so that the completed pavement shall conform to the required crown, grade, and cross section.

The joints of the vitrified brick pavement replacement shall then be filled with a 1:4 sand/cement mixture and/or pure sand. If pure sand, the pure sand must be sealed with Surebond SB-1300 Sealer or approved equal. The 1:4 sand/cement mixture of mortar grout shall be "soupy" and swept in with street brooms **or may be dry mixed, swept in with street brooms, consolidated by vibratory methods, and sufficiently moistened to ensure that cement sets.** If "soupy" application is used, then Contractor will blot the joints with sand after sweeping application to remove excess grout.

The application joint filler should take place immediately after laying the brick or as soon as possible thereafter to prevent joint from filling with other foreign matter.

WATER MATERIAL SPECIFICATIONS

GENERAL REQUIREMENTS

Materials shall be in accordance with these Specifications and shall, in no event, be less than as necessary for conformance to requirements of applicable laws, ordinances and codes. Materials to be in contact with potable water shall be listed by the National Science Foundation (NSF-61 listed) or by an approved certifying agency as conforming to the requirements of ANSI/NSF-61.

Materials provided for construction on or for the City's reclaimed water distribution system shall be in accordance with color coding specifications provided in the Florida Administrative Code (F.A.C.), Chapter 62-610.

All piping, pipeline appurtenances (including valves and outlets) shall be color coded to differentiate reclaimed water from domestic or other water. Underground piping which is not manufactured of metal shall be color coded or marked for reclaimed water distribution systems using Pantone Purple 522C using light stable colorants - underground metal pipe shall be color coded using purple as a predominant color. Visible, above-ground portions of the reclaimed water distribution system shall be clearly color coded or marked. All reclaimed water valves shall be appropriately tagged or labeled (bearing the words in English and Spanish: "Do not drink" together with the equivalent standard international symbol) to warn the public and employees that the water is not intended for drinking.

Items designated to be "domestically manufactured" shall be manufactured, assembled and tested in their entirety within the United States of America or its territories. Items designated to be "domestically assembled" may be foreign-manufactured but shall be assembled and tested in their entirety within the United States of America or its territories. Items requiring a "domestic presence" may be foreign-manufactured and/or assembled and/or tested, but the manufacturer shall have a designated representative or agent located within the United States of America, and that representative or agent shall be available to provide on-site service if required by the City of Tampa Water Department (Department).

All materials shall be new, unused, and correctly designed. They shall be of standard first grade quality, produced by expert workmen, and intended for the use for which they are offered. Materials or equipment which, in the opinion of the Department, are inferior or are lower grade than indicated, specified or required, shall not be accepted. All materials used in this contract must be approved in advance by the Engineer. In conformance with section G-4.02 of these contract documents, any two items of the same kind, type or classification, and being used for identical types of service, shall be made by the same manufacturer. Unless approved in advance by the engineer, only one manufacturer may be used for each item under this contract.

When submitting for approval materials not already approved by the Department at the time of request include manufacturer drawings and brochures that clearly indicate size, dimensions, weights, performance standards, etc.

POLYETHYLENE ENCASEMENT

1. GENERAL

Polyethylene encasement shall conform to the requirements of ANSI/AWWA C-105/A21.5 Method A and shall be 8-mil thick. Polyethylene encasement shall be installed on all buried ductile iron pipe, fittings, valves, and appurtenances where shown on the drawings or as directed by the Water Department as dictated by field conditions. It shall be blue in color.

2. PRODUCT

The raw material used to manufacture polyethylene encasement shall be Type 1, Class A Grade E-1 in accordance with ASTM D-1248. The polyethylene encasement shall meet the following test requirements:

Tensile Strength	1200 psi minimum
Elongation	300% minimum
Dielectric Strength	800 V/Mil thickness, minimum
Thickness	0.008" (8-mils (minimum nominal, with minus tolerance < 10% of nominal)
Melt Index	0.4 maximum

3. MANUFACTURER

All polyethylene encasement shall be domestically manufactured.

CASING SPACERS

1. GENERAL

Casing spacer sleeves shall be used to cradle carrier pipe through casing pipe.

2. PRODUCT

Casing spacer sleeves provided shall be either:

- a. two-piece, 12-gauge stainless steel strap which is heat fused PVC coated. Sleeve runners shall be an ultra-high molecular weight polymer with high resistance to abrasion and sliding wear. Runners shall be 2-inch or 2-½ inch in height. Or,
- b. projection type spacers, composed of a single-piece HDPE strap providing constant projections around the entire circumference of the carrier pipe. The minimum number of projections to be provided around the circumference shall total the number of diameter inches of the carrier pipe. Manufacturer-provided double-backed tape shall be used to fasten the HDPE casing spacer

strap tightly to the carrier pipe so that the spacers do not move during installation. Selection of spacer type and installation shall be in accordance with manufacturer's installation guidelines and recommendations.

Projection type spacers shall be ISO 9002 certified for strength and quality.

3. MANUFACTURER

Casing spacer sleeves shall be:

Raci Spacers North America Inc "RACI Projection-type HDPE Casing Spacer";
Cascade Manufacturing "CCS-450-1740" or "CCS-ER";
PSI CG-2 series; or approved equal.

PRE-CAST THRUST BLOCKS

1. GENERAL

Concrete precast thrust blocks shall be manufactured to the dimensions shown with the Standard Detail "Precast Concrete Thrust Blocks".

2. PRODUCT

The concrete for thrust blocks shall consist of a uniform mix of Portland cement, sand and gravel. The mix shall be proportioned and shall provide a dense concrete with a minimum compressive strength of 3,000 psi in 28 days. All material used in mixing concrete shall meet Florida Department of Transportation specifications.

3. MANUFACTURER

Not Specified.

TRANSITION COUPLING

1. GENERAL

Transition coupling shall be used to connect two plain end pipes of equal or slightly different outside diameters. Transition coupling shall also be used to connect different types of pipe. The transition coupling shall operate by placing two plain ends of pipe inside a rigid sleeve, and drawing in two compression glands upon two un-cut full circle gaskets to produce a seal between the ends of the rigid sleeve and the adjacent outside wall of the existing pipe.

2. PRODUCT

a. Transition coupling shall be composed of three parts: rigid sleeve, compression glands, and

City-wide Meter, Hydrant, and Valve Installation and Replacement
Contract 18-C-00030

gaskets.

- b. The rigid sleeve shall be manufactured of ferrous material that is protected against corrosion by epoxy coating or approved method during the working life of the fitting. The rigid sleeve shall be the "long-body" type.
- c. The compression gland shall be manufactured of ferrous material that is protected against corrosion during the working life of the fitting by epoxy coating or approved method. The glands shall be drawn in mechanically by bolts and nuts made of high-strength, low-alloy steel such as "Corten", "Usalloy", or "ACIPalloy".
- d. The gasket shall be EPDM. The gasket shall be resistant to permanent set during the working life of the fitting.
- e. Transition coupling for nominal size pipe of 2-inch shall be capable of connecting McWane enamel cast iron pipe to 2-inch PVC, SDR 21, pipe. Working pressure ratings shall be:

Type of Pipe	Size (in.)	Rated Pressure	O.D.
McWane Cast Iron	2	200	2.50
McWane Cast Iron	2.25	200	2.75
PVC (SDR 21)	2	200	2.38

The transition coupling shall be manufactured to meet these stated diameters.

- f. Transition coupling for nominal size pipe, 3-inch and greater, shall be capable of joining standard ductile iron pipe to pit cast iron pipe Class C-D, Asbestos-Cement pipe, PVC sch 40, PVC sch 80, or PVC pressure rated pipe. Transition coupling shall join different diameter pipes by the following means:
 - 1) by a coupling designed for stated diameters,
 - 2) by a coupling designed with a variable range using a compressible gasket,
 - 3) by a coupling with a variable range using different gaskets,
 - 4) or a coupling using any combination of described designs.

3. MANUFACTURER

Transition coupling for nominal size pipe 2 to 3 inches shall be:

City-wide Meter, Hydrant, and Valve Installation and Replacement
Contract 18-C-00030

Baker 200; Ford FCI/2/3; Dresser 38/138/40; JCM 212; Romac 501;
Rockwell 411/413/431/441/433; Viking Johnson; or approved equal.

Transition coupling for nominal size pipe 3-inches and greater shall be:

Baker 200/204/213; Ford FCI/2/3; Dresser 38/138/40/162;
JCM 212; Mueller H1020; ROMAC 501;
Rockwell 411/413/431/433/441; Viking Johnson; or approved equal.

BRASS FITTINGS

1. GENERAL

All brass fittings for service lines shall be included under this specification. Brass fittings include any and all required accessories.

2. PRODUCT

- a. All fittings shall be manufactured of brass, cast and machined in accordance with AWWA Standard C-800, latest revision.
- b. All fittings shall perform in accordance with AWWA C-800, latest revision.
- c. All fittings shall be certified as suitable for contact with drinking water in accordance with ANSI/NSF Standard 61, Drinking Water Components – Health Effects, Section 8. Certification shall be by an accredited certification organization or by a laboratory able to demonstrate that the NSF 61 lead testing protocol was followed.
- d. All brass fittings shall comply with Florida Administrative Code (F.A.C.) 62-555 (latest revision), the Safe Water Drinking Act, as amended, and the U.S Environmental Protection Agency (E.P.A.).
- e. All brass fittings shall be made of a “No-Lead Brass”, defined for this specification as brass alloy containing not more than one fourth of one percent (0.25% or less) total lead when used with respect to the wetted surfaces of the fitting, as defined by NSF/ANSI 61, Annex G and Annex F.
- f. All brass fittings shall be integrally stamped or cast with the manufacturer's name and a marking or trademark identifying that the fitting contains a “no lead” brass alloy (as defined herein), e.g., ‘NL’, ‘EB2’, or ‘FED’, etc.
- g. Manufacturer shall provide a copy of a letter from NSF International (on NSF letterhead) documenting compliance with NSF/ANSI 61 Annex F.

City-wide Meter, Hydrant, and Valve Installation and Replacement
Contract 18-C-00030

- h. All curb stops/meter valves shall be full-port and have a flow passage area equivalent to the fitting outlet flow area.
- i. Curb stops shall be of the ball valve design with a full-port opening ball no less than ¾-inch. 1-inch and larger curb stops shall be provided with padlock wings cast on stop body and operating tee cap to provide for locking the stop in closed position. ¾-inch curb stops shall be provided without padlock wings. Curb stops for use with copper or plastic service shall have an inlet connection with a pack joint compression nut (w/set screw) and an outlet connection with female iron pipe thread (FIP), as manufactured by:

Ford Meter Box Company (FMBC) [B41 for ¾-inch; B41W for ≥1-inch];
Mueller [P-25170N]; A.Y. McDonald [6102 for ¾-inch; 6102W-22 for ≥1-inch], or
approved equal.

Curb stops with Inside Iron Pipe Thread (FIP) inlet connections and an Inside Iron Pipe Thread outlet connections shall be:

FBMC [B11 for ¾-inch; B11W for ≥1-inch]; Mueller [B-20200];
A.Y. McDonald [6101W], or approved equal.

- j. Meter valves shall be of the ball valve design with a full-port opening ball no less than ¾-inch. Meter valves shall be provided with padlock wings cast on stop body and operating tee cap to provide for locking the stop in closed position. Meter valves for use with copper or plastic service shall have an inlet connection with a compression joint and a swivel nut outlet connection.

Angle meter valve:
FBMC BA43W, Mueller P-24258N, A.Y. McDonald 4602B-22, or approved equal;

Straight meter valve:
FBMC B43W, Mueller P-24350N, A.Y. McDonald 6100MW-22, or approved equal.

Straight meter valves with Inside Iron Pipe Thread inlet (FIP) and a Meter Swivel Nut outlet connection shall be: FMBC B13W; Mueller B-24351N; A.Y. McDonald 6101MW, or approved equal.

- k. Corporation stops shall be of the ball valve design. Corporation stop inlet connection shall be the AWWA Taper thread. The outlet connection shall be CTS pack-joint for copper or plastic tubing. Corporation stops for sizes ¾" – 2" shall be: FMBC FB-1000, A.Y. McDonald 4701B-22, Mueller P-25008N, or approved equal.
- l. Meter re-setters shall be designed for use with standard 5/8"x3/4" and 1" water meters. Resetters shall be constructed from brass fittings conforming to the specifications herein, with

copper riser pipes. An angle ball valve shall be provided on the inlet riser, saddle nuts and gaskets on inlet and outlet. Pipe connections shall be (nominal) male iron pipe size meter thread on both inlet and outlet. Meter re-setters shall be FMBC VB40 Series, Mueller B-24118R, A.Y. McDonald Series 18, or approved equal.

- m. Branch connections shall be brass construction with copper compression joint inlet and male iron pipe size outlets, as manufactured by FMBC U48, Mueller P-15363N, A.Y. McDonald 08U2M, or approved equal.

3. **MANUFACTURER**

Brass fittings shall be domestically manufactured by Mueller Company, Ford Meter Box Company, A.Y. McDonald Mfg. Company, or approved equal.

THREADED BRASS FITTINGS

1. **GENERAL**

Threaded brass fittings provided under this specification shall be manufactured in accordance with specifications stated herein.

2. **PRODUCT**

- a. Threaded brass fittings ("Fittings") provided shall be manufactured in accordance with ANSI B16.15., 125 lb.
- b. Fittings shall be of material conforming to ASTM B62 or B584.
- c. Threads on all fittings shall be N.P.T. in conformance with ANSI B1.20.3, right hand and shall be smooth, clean and true to form.
- d. Fittings shall be legibly cast or dye stamped such that the manufacturer's name, initial or other mark can be easily identified.
- e. All fittings shall be certified as suitable for contact with drinking water in accordance with ANSI/NSF Standard 61, Drinking Water Components – Health Effects, Section 8. Certification shall be by an accredited certification organization or by a laboratory able to demonstrate that the NSF 61 lead testing protocol was followed.
- f. All brass fittings shall comply with Florida Administrative Code (F.A.C.) 62-555 (latest revision), the Safe Water Drinking Act, as amended, and the U.S Environmental Protection Agency (E.P.A.).
- g. All brass fittings shall be made of a "No-Lead Brass", defined for this specification as brass alloy

City-wide Meter, Hydrant, and Valve Installation and Replacement
Contract 18-C-00030

containing not more than one fourth of one percent (0.25% or less) total lead when used with respect to the wetted surfaces of the fitting, as defined by NSF/ANSI 61, Annex G and Annex F.

- h. All brass fittings shall be integrally stamped or cast with the manufacturer's name and a marking or trademark identifying that the fitting contains a “no lead” brass alloy (as defined herein), e.g., ‘NL’, ‘EB2’, or ‘FED’, etc.
- i. Manufacturer shall provide a copy of a letter from NSF International (on NSF letterhead) documenting compliance with NSF/ANSI 61 Annex F.

3. MANUFACTURER

Threaded brass fittings shall be domestically manufactured by Mueller Company, Ford Meter Box Company, A.Y. McDonald Mfg. Company, or approved equal.

SERVICE SADDLES

1. GENERAL

Service saddles shall be used for tapping water distribution pipes to provide a drip-tight connection to the main for customers' water meters. Service saddles shall incorporate a wrap-around type body, straps, gasket and bolts. When installed, the body shall wrap around the main for a minimum of 160 degrees.

2. PRODUCTS

- a. Service saddle for pipe less than 3-inches shall be single band which is hinged or split from the saddle body and is anchored by bolting one or more bolts between the band and saddle body, or a double strap design anchored by four bolts.
- b. Service saddles for pipe equal to or greater than 3-inches shall use a double-wide single flexible band or a double strap with a minimum of a four bolt pattern anchoring. These service saddles shall provide for a variable range in diameter per nominal size of pipe, yet shall fit the stated diameter for the nominal size pipe noted.
- c. Service saddles shall be constructed from bronze, ductile iron in accordance with ASTM A536, or stainless steel and shall seal to the distribution pipe by an EPDM rubber gasket. The gasket shall maintain a resilient seal without cracking or becoming brittle during the working life of the service saddle. All service saddles shall have corporation tap threads.
- d. Threads shall be AWWA CC in accordance with AWWA C-800.
- e. Gasket shall be of self-sealing design.

- f. Service saddle bodies shall be protected with a heavy coating of corrosion resistant, metal primer.
- g. Service saddles provided shall be suitable for use with water of 100 degrees Fahrenheit and pressure up to 150 psi without rupture and failure.
- h. Straps and bolts shall be carbon steel conforming to ASTM A108, electro-galvanized with dichromate seal.

3. MANUFACTURER

Service saddles for 2-inch or less pipe and 3-inch or greater pipe shall be as follows:

2-inch or less:

Clow 3401	Ford 570/590	JCM 401/402/403/405 (DI)
Jones J-995	Rockwell 313/317	Ford FS-/ FC-202; F101/202
Smith Blair 311		Mueller H-13420/10475-76

3-inch or greater:

Cascade C-S22/CDS2/CNS2/CSC2	Mueller H-105XX series
Rockwell 313 (DI) /317/323	Clow 3408/3410
JCM 402 cortin strap (for DIP)	Smith Blair 311
Ford FS- or FC-202 series	JCM 406 (for PVC)

or approved equal.

BLOW-OFF ASSEMBLY

1.0 GENERAL

Blow-off assemblies shall be used to remove sediments and stagnant water from non-looping or "dead-end" water lines.

2.0 PRODUCT

2.1 GENERAL

- a. There are two approved Std. Construction Details for blow-off assemblies - one for four-inch and larger pipe, the second for two-inch pipe.
- b. The Contractor shall furnish all parts for the complete assembly, including but not necessarily limited to gate valves, hydrant adapters, meter boxes, valve boxes, caps or plugs on the water main, a cap on the hydrant adapter, one MJ restraining device or

MJ adapter for the cap or plug on the main and all related appurtenances.

- c. The outlet shall have 2-1/2-inch fire hydrant threads and a cap.

2.2 BLOW-OFF ASSEMBLY for 4-INCH AND LARGER PIPE

- a. Blow-off assembly shall connect to the end of the existing pipe through a tapped plug or cap. A two-inch corporation shall be threaded into the tapped cap/plug. Two-inch HDPE tube shall run from the two-inch corporation to a two-inch gate valve.
- b. The gate valve shall have a standard operating nut and have a standard valve box, brought to grade in conformance with the appropriate standard detail.
- c. Two-inch HDPE tubing shall run from the gate valve and terminate in 2-1/2-inch NST by 2-inch MIP brass hydrant adapter. The adapter shall have a threaded cap and shall be placed in a #37 meter box, set to grade.

2.3. BLOW-OFF ASSEMBLY for 2-INCH PIPE

- a. A two-inch gate valve shall be installed on the two-inch pipe.
- b. The gate valve shall have a standard operating nut and have a standard valve box, brought to grade, in conformance with the appropriate standard detail.
- c. Two-inch HDPE tubing shall run from the gate valve and terminate in 2-1/2-inch NST by 2-inch MIP brass hydrant adapter. The adapter shall have a threaded cap and shall be placed in a #37 meter box, set to grade.

3. MANUFACTURER

None specified. The installation shall conform to the appropriate Standard Detail.

AIR VACUUM AIR RELEASE VALVES (AVAR)

1. GENERAL

Air and vacuum valves shall be fully automatic capable of venting large quantities of air while pipeline is being filled, allowing air to re-enter while pipeline is being drained (or when negative pressure occurs), and to continuously and automatically release air from a pressurized liquid system. Single body or dual body Combination Air Valves shall be installed.

Air and vacuum valves shall be of the size indicated, with flanged or screwed ends to match piping. Bodies shall be of high-strength cast iron. The float, seat, and moving parts subject

to wetting shall be constructed of Type 316 stainless steel. Seat washers and gaskets shall be Buna-N seal to provide an initial contact to Buna-N with final metal contact to prevent over compression of the resilient seal. Valves shall be designed for minimum 150 psi water-working pressure, unless otherwise indicated.

Air vacuum air release valves shall be installed inside of a Charles Industries fiber optic pedestal (Part No. 117 SS07 – 2 0 000 BK), generally in accordance with Standard Detail 2.14C (Automatic Air Release Valve) and 2.15 (Pedestal for Automatic Air Release Valve), having a buried, square base with a louvered low-profile above-grade dome. Base (pedestal) shall be fully buried on grade such that the dome/pedestal interface is 1” min. above finished grade.

A blue reflective sticker announcing COT Water ARV (to be provided by the City Inspector) shall be affixed to the dome, as directed by the Inspector, in accordance with manufacturer recommendations.

2. **PRODUCT**

Air Vacuum and Air Release Valves shall be manufactured and tested in accordance with AWWA Standard C512 for clean water.

Combination Air and Vacuum Valves shall have the same general requirements as indicated above. Two inch and smaller combination air valves for clean water applications shall be of the integral type with a valve assembly which functions as both an air and vacuum valve and an air release valve.

3. **MANUFACTURER**

Combination Air and Vacuum Valves: The valves shall be Val-Matic 201- or 202C Combination Air Valve, Apco Single Body Combination Air Valves, Crispin C-Series Combination Air Valves, Crispin Universal Air Release Valves, or approved equal. Unless otherwise specified or indicated on the drawings, all combination valves shall be provided with surge check discs on the valve inlet to restrict the exhaust air flow rate.

AIR RELEASE VALVES **(Compound Lever Type)**

1. **GENERAL**

Air Release Valves shall be manufactured in accordance with AWWA C512 or latest revision, and shall adhere to the following specification.

2. **PRODUCT**

The air release valve shall be of the float operated, compound leverage type, and be capable of automatically releasing accumulated air from a fluid system while that system is in operation

and under pressure.

To ensure drop tight shut off, a buna-n orifice button shall be used to seal the valve discharge orifice. The orifice diameter must be sized for use within a given operation pressure range to insure maximum discharge capacity.

Air release valves shall be provided with a vacuum check to prevent air from re-entering the system on negative pressure.

All internal trim metal subject to wetting shall be stainless steel. The float shall be of stainless steel construction and capable of withstanding a pressure of 1,000 p.s.i.

3. **MANUFACTURER**

Air release valves shall be manufactured by Val-Matic Valve and Manufacturing Corp., Model No. 38VC; APCO Model 200 with vacuum check, or approved equal.

VAULT SLABS AND COVERS

1. **GENERAL**

Vault slabs and covers shall adhere to all specifications stated herein.

2. **PRODUCT**

Vault slabs shall be constructed of reinforced concrete or reinforced polymer concrete. Vault slabs shall be dimensioned as shown in Tampa Water Department Standard Detail, Vault Concrete Slab Detail.

a. Concrete Vault Slabs

- 1) The concrete shall consist of a uniform mix of Portland cement, sand, and gravel. The mix shall provide a dense concrete with a minimum compressive strength of 4,500 psi in 28 days. The gravel shall be a clean, physically sound, high density, well graded, washed pea gravel with a maximum size of ½-inch. The sand shall be sharp, clean and well graded. All material used in mixing concrete shall meet Florida Department of Transportation specifications. The water/cement ratio by weight shall be less than .45 and the slump shall be kept to a minimum of 3-inches and a maximum of 4-inches. The top surface of all slabs shall be a broom finish.
- 2) All concrete vault slabs shall be reinforced with rebar throughout the slab and with welded wire fabric around the lift loop depressions. The rebar shall be Grade 60, No. 6 in all top slabs and Grade 60, No. 4 in all bottom slabs. All lift loops shall be Grade 60, No. 4 rebar and shall be dimensioned as shown in construction standard Detail 6.08. All lift loop depressions shall be centered in a 9-hole square pattern of 6" x 6" welded wire fabric.

b. Reinforced Polymer Concrete Vault Slabs

The polymer concrete shall consist of a mix of polymer resin, coarse sand, fine sand and shall be reinforced with layers of woven fiberglass to withstand a minimum of an H-10 loading. Polymer concrete shall have a minimum compressive strength of 12,000 psi. Thickness of polymer concrete vault slabs may be less than shown in the Tampa Water Department Standard Detail, Vault Concrete Slab Detail, provided the minimum H-10 loading requirements are met. Polymer concrete vault slabs shall be provided with Lift Loops as described in this standard and as shown in the Standard Detail.

c. Vault Covers

Top vault slabs shall be provided with a reinforced polymer concrete vault cover ("Vault Cover"). Vault cover frames in concrete vault slabs shall be fabricated of steel, cast flush into the top surface of the top vault slab, and dimensioned as shown in the above referenced Standard Detail. Vault covers shall be reinforced polymer concrete as specified in 2.b. above and dimensioned as shown in the Standard Detail. Vault covers shall be bolt down with ½-inch penta head corrosion resistant bolts and shall not exceed 150 lbs. in weight. Each vault cover shall have the City embossed seal as shown in the above referenced Standard Detail. Vault covers shall be provided with ¾" x 2" lifting holes with lift loops for engaging a raising hook to remove the vault cover.

3. MANUFACTURER

- a. Reinforced polymer concrete vault slabs shall be CDR Systems WP series, or equal.
- b. Reinforced polymer concrete vault covers shall be CDR Systems C10- 3048-03W, or equal.

WATER METER BOXES & COVERS

1. GENERAL

Water meter boxes ("Meter Boxes") and covers ("Covers") shall be manufactured in accordance with these specifications.

Covers provided shall be designed to withstand incidental loading or heavy traffic ("extra-heavy") loading as specified herein.

Meter boxes and covers provided shall be in accordance with City of Tampa Water Department "Standard Details" for meter boxes (see Details 5.10A, 5.11A, 5.12A & 5.13).

Meter boxes and covers provided for potable water service shall be black in color and meet loading requirements as specified herein.

Meter boxes and covers provided for reclaimed water (RCW) service shall be colored Pantone purple. Covers for RCW meter boxes shall include “NO BEBER”, and the universal symbol for DO NOT DRINK (the glass with a line (or “x”) through it).

2. PRODUCT

2.1 Meter Boxes

Meter boxes shall be LLD- or HD-polyethylene of one-piece molded construction, with dimensions as shown in the referenced drawings. The boxes shall be designed to meet the requirements for AASHTO Incidental Traffic H-10 loading.

All edges shall be clean and smooth for safety during handling. Exterior wall shall be of smooth finish, black in color, and have ultraviolet degradation protection properties for above ground storage (except reclaimed water meter boxes shall be purple). Interior wall shall be of smooth finish and black or white color (except reclaimed water meter boxes shall be purple).

Meter boxes shall not exceed 25 lbs. in weight, shall have pre-cut pipe entry areas, and be designed to be securely stackable.

Meter boxes shall be dimensioned to accommodate meter box covers as specified below.

2.2 Meter Box Covers shall:

- i. be made of modified polyethylene or bulk molded compound composite material to prevent floating in high water conditions;
- ii. be one-piece molded construction, with dimensions and lettering as shown in the referenced meter box Std. Detail drawings;
- iii. be designed to meet the requirements for AASHTO Incidental Traffic H-10 loading;
- iv. be “anti-float”, demonstrated by having a specific gravity $>1.0 \text{ gm/cm}^3$ (ASTM D792).
- v. include snap-lock pockets (slide mounts) on the underside to receive an AMR/AMI device endpoint. Snap-lock slot shall be of size sufficient to allow for a finger force install of an AMI transmitter, and pocket height shall be sufficient to allow a minimum 1/8” air gap.
- vi. include minimum #3 rebar or other tested and proven means of enabling magnetic location of the cover when it is buried.

City-wide Meter, Hydrant, and Valve Installation and Replacement
Contract 18-C-00030

vii. be sized to fit the appropriate Brooks Products, Inc., Orlando, Florida concrete meter boxes, numbers 36, 37, 66 and Dual H:

Description	¾" Dual	¾" or 1" Single	1½"-2" Single	Dual w/BFP
Meter Box Type	Dual H	#37	#66	13 x 24
Meter Box	16-9/16" x 14-	18-1/8" x 11-	30-1/2" x 17-1/2"	13 ¾" x 23 ¼"

Composite covers shall have a minimum coefficient of friction of >0.5 (ASTM 1028), to prevent pedestrian slip hazard. Polyethylene covers shall have a molded tread-pattern for skid resistance.

“Extra-heavy” covers provided shall be designed to meet the requirements for AASHTO Full Traffic H-20 loading.

3. MANUFACTURER

Water meter boxes and meter box covers provided shall be equal to or better than:

Meter Boxes:

DFW Plastics, models:

DFW37C-12-BODY; DFW39C-12-BODY;

DFW1730CH-12-BODY; DFW 1324C-12-BODY

(for RCW boxes, insert a 5 after the “C “or “CH” in the model name)

Oldcastle Enclosure Solutions, models:

1015-12 BCFXL (#36); 1118-12 BCFXL (#37); 1416-12 BCFXL (Dual);

1730-12 BCFXL (#66); 1324-12 BCFXL (Dual Meter & w/BFPs).

Meter Box Covers:

DFW Plastics, models:

DFW37C-AF1EA TPA-LID; DFW39C-AF1EATPA-LID;

DFW1730C-AF1EA TPA LID; DFW1324C-AF1EA TPA-LID

(for DFW RCW covers, change the 1 to a 5 in the model name)

Oldcastle Enclosure Solutions “Fibrelyte”, models:

FL9X (36), FL12 (37), FL1416 (Dual), FL36 (66), FL30 (Dual BFP)

RESTRAINT DEVICES

(for Push-on-, Mechanical-, and Flanged Joint Pipe and Fittings)

1. GENERAL

Mechanical restraint devices shall be used to restrain plain ends of ductile iron, PVC or HDPE pipe to push-on, mechanical, or flange joints, or fittings which meet ANSI/AWWA C-110/A21.10 and ANSI/AWWA C-111/A21.11, latest revisions.

Wedge action restraint for mechanical and flange joint pipe and fittings shall be incorporated in the design of the follower gland and shall include a restraining mechanism (the lug) which, when activated, imparts multiple wedging actions against the pipe, thereby increasing its restraint on the pipe as the joint tries to separate. "Twist-off nuts" shall be used to ensure proper actuating of the restraining device.

Restraint devices used with PVC pipe shall be those designed for (and recommended by the pipe manufacturer) for use on PVC pipe. PVC restraining devices shall meet or exceed all requirements of ASTM F1674 "Standard Test Method for Joint Restraint Products for Use with PVC Pipe".

When mechanical restraint devices are used for connecting plain ends of HDPE pipe to mechanical joint fittings and valves, manufacturer recommended stainless steel inserts are required.

2. PRODUCT

a. Push-on Joint Restraint (for 4" - 36" ductile iron pipe only)

Restraint of push-on joint ductile iron pipe may be with "locking" or "gripper" gaskets, consisting of an EPDM rubber gasket with high-strength stainless steel locking elements vulcanized into the gasket, which when activated develop wedging action between the pairs of stainless steel elements spaced around the gasket and the pipe.

b. Flange Joint Restraint

Flange joint restraint fittings shall include individually activated gripping wedges and gaskets. Flange joint restraint fittings shall attach to the plain end of a pipe by wedge screws to produce a flange which joins to an existing integral companion flange. Flange joint restraint fittings shall be constructed of ductile iron meeting ASTM A536 and manufactured in accordance with ANSI/AWWA C-110/A21.10 (or C-153/A21.53) and C-111/A21.11, latest revision. All flanges shall have bolt circle and bolt holes which match a Class 125 flange and are compatible with ANSI/AWWA C-115/A21.15. Gasket shall be made of EPDM rubber.

c. Mechanical Joint Restraint

The wedge action follower glands shall be manufactured of ductile iron conforming to ASTM A536-80. The wedging lug and bolt shall be manufactured of ductile iron which has been heat-treated to a minimum hardness of 370 BHN.

Wedge action glands shall be dimensioned such that they can be used with standard mechanical

joints and have tee-head bolts conforming to ANSI/AWWA C-111/A21.11 and ANSI/AWWA C-153/A21.53, latest revision.

d. Existing Pipe Joint Restraint

(1) Split-restraint fittings for mechanical joints on existing pipe installations shall be manufactured in accordance with these technical specifications; however, split-restraint fittings shall be segmented to allow restraint of existing ductile iron mechanical joints meeting AWWA C111.

(2) Split-restraint fittings for existing pipe bell-and-spigot joints shall consist of split restraint rings, one installed on the pipe barrel behind the bell. Restraint devices shall be ductile iron per ASTM A536, latest revision, min. Grade 60-42-12. Threaded rods shall be high strength low-alloy steel per AWWA C111, latest revision.

e. Coatings

(1) Flange Adapters shall be provided with painted "shop coat", or approved equal.

(2) Retainer glands shall be provided with a bituminous coat.

(3) Existing pipe push-on joint restraint fittings shall be provided with a bituminous coat.

3. QUALITY CONTROL AND TESTING

a. Pipe restrained with mechanical restraint devices specified shall be capable of withstanding the following pressures:

Push-on and Mechanical Joint -	4" - 16"	min. 350 psi
	>16"	min. 250 psi
Flanged Joint -	4" - 36"	min. 250 psi

4. MANUFACTURER

a. Ductile iron pipe push-on joint restraint devices shall be U.S. Pipe "Field-Lok" Gasket, American "Fast-Grip" Gasket, or approved equal.

b. Ductile iron pipe flange joint restraint devices shall be approved, equal to, or better than EBAA Iron "Megaflange Series 2100" or "1000 EZ Flange", or Ford Meter Box Company "Uni-flange Series 400-C".

c. Wedge action restraint for ductile iron pipe mechanical joints shall be equal to or better than EBAA Iron "Megalug, Series 1100", Tyler/Union TUF Grip TLD, Sigma One-Lok Model SLD

(4" to 36") or approved equal.

- d. Split, wedge-action restraints devices for restraint of existing ductile iron pipe and fitting joints shall be EBAA Iron "Megalug, Series 1100-SD, or -HD", or approved equal.
- e. Restraint of PVC pipe bell-and-spigot joints shall be made with Uniflange 1350C; Uniflange 1390C; Megalug 1600; Sigma PV-Lok Series PVP; or approved equal.
- f. Restraint of PVC pipe spigot-end to the mechanical joint of fittings or valves shall be made with the Megalug 2000PV; Tyler/Union TUF Grip TLP; Uniflange 1300C; Sigma One-Lok Models SLC or PVM; or approved equal.

DUCTILE IRON PIPE

(Push-On-, Mechanical-, Flexible-, and Manufactured Restrained Joint)

1. GENERAL

Ductile iron pipe shall be domestically manufactured in accordance with the latest revision of ANSI/AWWA C-151/A21.51. Pipe shall be furnished in 18- or 20-foot laying lengths. Pipe shall be lined with a standard thickness cement mortar lining and seal coated in accordance with the latest revision of ANSI/AWWA C-104/A21.4 and NSF 61. Pipe outside coating shall be an asphaltic coating in accordance with ANSI/AWWA C-151/A21.51, latest revision. All pipe materials used in potable water systems shall comply with NSF Standard 61. Unrestrained joint pipe shall be either the rubber-ring compression-type push-on joint or mechanical joint.

2. PRODUCTS

a. Push-on Joint Pipe

Push-on joint pipe shall be supplied with all joint accessories. Accessories shall include gaskets and lubricant in sufficient quantity for the proper assembly of each joint. Gaskets for push-on joints shall be made of ethylene propylene diene monomer (EPDM) rubber, except: Acrylonitrile butadiene (NBR) gaskets shall be used for potable water mains that are located in soil that is contaminated with low molecular-weight petroleum products or non-chlorinated organic solvents or non-aromatic organic solvents. Fluorocarbon (FKM) gaskets shall be used for potable water mains that are located in soil that is contaminated with aromatic hydrocarbons or chlorinated hydrocarbons. Fluorocarbon (FKM) gaskets shall be used for potable water mains if the soil is contaminated with aromatic hydrocarbons or chlorinated hydrocarbons, and is also contaminated with low molecular-weight petroleum products or organic solvents. All plain ends shall be painted with a circular stripe on the pipe barrel to allow a visual means of checking proper assembly.

- All push-on joints shall be in accordance with ANSI/AWWA C-111/A21.11, latest revision.
- Pressure Class shall be as follows:

City-wide Meter, Hydrant, and Valve Installation and Replacement
Contract 18-C-00030

<u>Diameter</u>	<u>Min. Pressure Class</u>
4" to 16"	350
> 16"	250

b. Mechanical Joint Pipe

- Mechanical joint pipe shall be supplied with all joint accessories. Accessories shall include lubricant, gaskets, ductile iron glands, bolts, and nuts, all in sufficient quantity for the assembly of each joint. The bolts and nuts shall be manufactured of high-strength, low-alloy steel such as "Corten", "Usalloy", or "Acipalloy". The follower gland shall be ductile iron. Gaskets for mechanical joints shall be made of ethylene propylene diene (EPDM) rubber.
- All mechanical joints shall be in accordance with ANSI/AWWA C-111/A21.11, latest revision.
- Pressure Class shall be as follows:

<u>Diameter</u>	<u>Min. Pressure Class</u>
4" - 16"	350
> 16"	250

c. Flexible Joint Pipe

- Flexible-joint pipe shall be push-on, ball-and-socket, freely deflecting, and restrained using a corrosion resistant locking device. Thickness class shall be as follows:

<u>Diameter</u>	<u>Min. Thickness Class</u>
6"	54
8"	55
12"	56
16"	57

The joint shall be capable of a full 15° free deflection with no reduction in the waterway.

d. Manufactured Restrained Joint Pipe

- Joints shall be push-on in accordance with ANSI/AWWA C-111/A21.11. Joints shall be secured by wedged locking shims or a follower gland which shoulder against a retaining ring permanently fastened to the spigot end of the pipe within the joint. Gaskets for manufactured restrained pipe joints shall be made of EPDM rubber.
- Pressure Class shall be as follows:

<u>Diameter</u>	<u>Min. Pressure Class</u>
4" - 16"	350
> 16"	250

3. MANUFACTURER

- a. Ductile iron pipe, unless specified below, shall be by U.S Pipe, American Cast Iron Pipe Company, McWane Cast Iron Pipe Company, Griffin Pipe Products Company, or approved equal.
- b. Flexible Joint pipe shall be American Ductile Iron "Flex-Lok Boltless Ball Joint Pipe", U.S. Pipe "USI FLEX Boltless Flexible Joint Pipe", Griffin Pipe Products "Snap-Lok River Crossing Pipe", or approved equal.
- c. Manufactured Restrained Joint pipe shall be American Ductile Iron "Flexring", U.S. Pipe "TR-Flex", McWane Cast Iron Pipe Company "Super-Lock" (20" & 24" pipe) and "Thrust-Lock" (30" & 36"), Griffin Pipe Products "Snap-Lok", or approved equal.
- d. All ductile iron pipe shall be domestically manufactured in the United States.

DUCTILE IRON PIPE- FLANGED

1. GENERAL

The flanged pipe shall be ductile iron domestically manufactured in accordance with ANSI/AWWA C-151/A21.51 and the National Association of Pipe Fabricators (NAPF) Product Standard 300, latest revisions, in nominal 18 or 20 foot laying length. The pipe shall be minimum Special Thickness Class 53 rated for a maximum working pressure of 250 psi, per ANSI/AWWA C-115/A21.15, latest revision.

2. PRODUCT

- a. All flanges shall be ductile iron and shall be manufactured and installed on the ductile iron pipe in accordance with ANSI/AWWA Standard C-115/A21.15, and the National Association of Pipe Fabricators (NAPF) Product Standard 300-01, latest revisions. Bolt circle and bolt holes shall be drilled and faced to match American National Standards Institute (ANSI) B16.1, Class 125 Flanges. All necessary hex-head bolts and nuts, and full-faced gaskets for each joint size shall be furnished as a Flange Accessory Package. Bolts and nuts shall be high-strength, low-alloy steel such as "Corten", "Usalloy", or "AciPalloy". Gaskets shall be made from EPDM rubber.
- b. Plain ends of flange ductile iron pipe shall be slightly beveled for use in a push-on joint assembly. A circular stripe painted on the pipe barrel shall be provided as a visual means of checking proper assembly when used in a push-on joint.
- c. All pipe interiors shall be lined with standard thickness cement mortar in accordance with ANSI/AWWA C-104/A21.4 latest revision. All pipe exterior surfaces shall be coated as specified in ANSI/AWWA C-151/A21.51, latest revision.

3. MANUFACTURER

All flanged ductile iron pipe shall be domestically manufactured by U.S. Pipe, American Cast Iron Pipe Company, McWane Cast Iron Pipe Company, or approved equal.

HDPE (High Density Polyethylene) PIPE

1. GENERAL

HDPE pipe shall be manufactured in accordance with the latest edition of AWWA C906. Pipe shall be furnished in 40-foot laying lengths.

2. PRODUCTS

- a. Carrier: HDPE pipe shall be made of resin approved by the National Sanitation Foundation (NSF).
- b. All HDPE pipe, sizes 4-inch and larger, shall meet the requirements of AWWA Standard C 906-99 (or most recent revision).
- c. Pipe outside diameter shall be ductile iron pipe size.
- d. All HDPE pipe shall meet the requirements of NSF Standard 61.
- e. All HDPE pipe shall be made of materials conforming to polyethylene code designation PE 4710, with a minimum cell classification of PE 454474 C or higher.
- f. Standard dimension ratio shall be DR-11
- g. Pressure class shall be 160 psi.
- h. The piping shall be permanently blue-coded to provide water main identification. When pipe is striped, stripes shall be blue, along the entire outside length of the pipe 90 or 120 degrees apart, and shall be made by co-extrusion or impregnation. Fully colored blue pipe co-extruded from permanently pigmented HDPE is also acceptable. Color shall be green for Wastewater applications.
- i. Markings on the pipe shall include the following:
 - Nominal size and OD base
 - Standard material code designation
 - Dimension
 - Pressure class

- AWWA designation (AWWA C906-99)
- Material test category of pipe
- Manufacturer's test code

3. MANUFACTURER

HDPE Pipe provided shall be:

CRS "PolyPipe", PE 4710; Quail Piping, PE 4710;
Performance Pipe's "DriscoPlex 4000 Series", PE-4710, 4" to 12" diameter;
or approved equal.

HDPE TUBING

1. GENERAL

- a. All water service lines two (2) inches in diameter and smaller shall be constructed of high-density polyethylene (HDPE) tubing.

2. PRODUCT

- a. Polyethylene extrusion compound from which the PE pipe and tubing are extruded shall comply with the applicable requirements for the Type III, color and U.V. code E, Class C, PE 4710, very high molecular weight polyethylene plastic material manufactured in accordance with AWWA C-901, latest revision, as specified in ASTM D1248. 2-inch and smaller HDPE pressure tubing shall have a color and ultraviolet code E and a minimum cell classification of PE 454474 E as specified in ASTM D3350.
- b. The polyethylene extrusion compound shall be of virgin quality approved for potable water service by the National Sanitation Foundation. The polyethylene extrusion compound shall be manufactured with sufficient and proper ultra-violet color stabilizers.
- c. Polyethylene tubing shall be SDR-9 200 psi.
- d. The standard dimension ratio (SDR) shall be 9 for CTS tubing sizes. The average outside diameter, minimum wall thickness and respective tolerances for any cross-section shall be as specified in ASTM D2737. The average inside diameter, minimum wall thickness, and respective tolerances for any cross-section shall be as specified in ASTM D2239.
- e. Polyethylene tubing shall be blue and have U.V. color stabilizers so that the pipe is not affected in color or flexibility for a minimum of four (4) years.

3. QUALITY CONTROL AND TESTING

- a. Environmental stress cracking resistance testing shall be performed in accordance with ASTM D1693, Condition C, and shall have no failures after 5000 hours duration.

4. **MANUFACTURER**

All HDPE tubing shall be:

Performance Pipe "DriscoPlex"; Endot "EndoPure"; Vanguard "Bruiser"
Charter Plastics "Blue Ice"; or approved equal.

PVC (Polyvinyl Chloride) WATER PIPE

1. **GENERAL**

All PVC pressure pipe shall be manufactured in accordance with AWWA Standard C-900, latest revision.

2. **PRODUCT**

- a. Pipe - PVC pipe, 4" through 16", shall be DR-18 pressure class 235 with ductile iron pipe equivalent ODs. The pipe shall be approved by the National Sanitation Foundation for use as a potable water main. The pipe color shall be blue and the nominal laying length per pipe section shall be 20 ft.
- b. Joints - Joints shall be "push-on" and shall be made by joining pipe spigot end and integral wall-thickened bell end. All joints shall meet all requirements of ASTM Standard D3139. Each bell shall be an integral-wall section joint assembly using elastomeric-gasket seals. All gaskets shall meet all requirements for performance as specified by ASTM F-477. All integral joint gaskets shall be made of EDPM rubber.
- c. Service Taps- All service taps on PVC mains shall require a service saddle, manufactured specifically for PVC pipe, equal to or better than Ford FS- or FC-202, or JCM 406. The cutting tool shall be a shell type for PVC pipe (hole) cutter with internal teeth or double slots and be designed to accommodate AWWA C-900 pipe (twist drill bits and auger bits shall be prohibited). The saddles used should provide full support around the circumference of the pipe and provide a bearing area of sufficient width along the axis of the pipe (2" minimum), ensuring that the pipe will not be distorted when the saddle is tightened.
- d. All PVC pipe shall be installed with tracer wire, per the Tracer Wire specifications.

3. **MANUFACTURER**

Un-restrained push-on joint C-900 PVC DR18 pipe shall be domestically manufactured and shall be equal to or better than:

Vasallo C-900 ; Diamond Plastics C-900; JCM C900 PVC pipe; or

North American Pipe Corporation C-900

Restrained joint PVC pipe shall be equal to or better than JM Eagle “Eagle Loc 900” or CertainTeed Certa-Lok C900/C905 RJ PVC.

LOCATING (TRACER) WIRE

1. GENERAL

All tracer wire installed shall be insulated, blue coated, solid UF (Underground Feeder per National Electric Code Article 339) copper tracer wires for water main location purposes by means of an electronic line tracer.

2. PRODUCT

Tracer wire for direct bury installations shall be approved insulated copper clad steel (CCS) wire. Wire insulation shall be minimum 30 mil high-density, high molecular weight polyethylene (HDPE) colored to meet the APWA color code standard for identification of buried utilities. Conductor must be at 21% minimum conductivity for locate purposes, and be able to withstand a minimum 450 lb. break load.

Wire splices must be with wire connectors suitable for buried service (be corrosion- and moisture-proof) such as the

Sizes (gauges) for direct bury pipe tracer wire shall be as follows:

16-in. and larger ductile iron pipe: **10 AWG**

PVC pipe: **12 AWG**

Long-side meter service line (direct bury and directional drilled): **12 AWG**

Tracer wire for directional drilled or bored-in pipe shall be approved insulated **10 AWG** copper clad steel wire insulated with 45 mil, high-density, high molecular weight polyethylene (HDPE), and rated for direct burial use at 30 volts minimum. Conductor must be at 21% minimum conductivity for locate purposes, and be able to withstand a minimum 1150 lb. break load.

Tracer wire for Pipe Bursting shall be approved insulated copper clad steel wire, insulated with a 50 mil, high-density, high molecular weight polyethylene (HDPE) insulation, and rated for direct burial use at 30 volts minimum. Conductor must be at 21% minimum conductivity for locate purposes, and be able to withstand a minimum 4700 lb. break load.

3. MANUFACTURER

Tracer wire shall be:

for direct bury pipe:

Copperhead High Strength Tracer Wire, or

Pro-Trace HF-CCS PE45 Tracer Wire
for directional drilled pipe:
Copperhead SoloShot™ extra-high-strength copper-clad steel (EHS-CCS
for pipe bursting:
Copperhead Industries SoloShot™ Xtreme, 7x7 stranded Copper Clad Steel
Wire splices for tracer wire:
DBR Kit (by 3M), Snakebite (by Copperhead Industries),
or approved equal.

GATE AND TAPPING VALVES, RESILIENT SEAT

1. GENERAL

All gate valves shall conform to AWWA C-509 or AWWA C-515 and requirements contained herein.

2. PRODUCT

AWWA C-509 VALVES (Cast Iron or Ductile Iron) and AWWA C-515 (Ductile Iron)

a. General

- 1) Resilient Seat Gate Vales ("Valves") provided under this specification shall be suitable for installation on ductile iron or cast iron pipe, and C-900 PVC. Valves shall be manufactured in accordance with AWWA C-509 or AWWA C-515, latest editions, as applicable, and as specified herein.
- 2) "Standard valves" shall refer to resilient seat gate valves with mechanical joints at both ends meeting specifications stated herein.
- 3) "Tapping valves" shall refer to resilient seat gate valves with one end mechanical joint, and one end flanged, meeting specifications stated herein.
- 4) Resilient seats for valves shall be made of EPDM rubber.
- 5) Mechanical joint gaskets shall be made of EPDM rubber.

b. Standard and Tapping Valves

- 1) Valves shall be of the non-rising stem type that shall open by turning a two-inch square AWWA operating nut clockwise (open right).
- 2) Valve stems shall be stainless steel and manufactured in accordance with AWWA C-509/C-

City-wide Meter, Hydrant, and Valve Installation and Replacement
Contract 18-C-00030

515. Stems, stem-nuts and wedges shall act independently. Stems shall be sealed by at least two O-ring seals, one located both above and below the thrust collar. Stems shall be provided with low friction torque reducing thrust bearings. Thrust washers may be used to separate the thrust collar from iron surfaces.

3) Valve bodies and gates shall be cast iron or ductile iron manufactured in accordance with ASTM A126 or ASTM A536 respectively, and AWWA C-509 or AWWA C-515 as applicable, latest revisions. All internal and external exposed ferrous surfaces of the valve body and gate shall have an epoxy coating applied to a minimum of eight mils, in accordance with AWWA C-550 latest edition. Non-metallic resilient seats shall be bonded to the gate; mechanically attached seats will not be accepted. The method of bonding shall be approved by ASTM D429 A or B as specified in AWWA C-509/C-515. Hollow gates shall be provided with a drain in the bottom to flush the internal cavity of foreign material and stagnant water each time the valve is operated.

4) All bonnet bolts, gland bolts, nuts and other trim hardware exposed to the outside environment shall be stainless. Thrust collar tie-rod bolts shall be stainless steel.

5) Mechanical joints and accessories shall be manufactured in accordance with AWWA Standard C110 and C111, latest revision, with exceptions noted herein. Mechanical joint bolts-and-nuts shall be manufactured of high-strength, low-alloy steel such as "Corten", "USalloy", or "ACIPalloy". Joints requiring a shorter bolt than called for in AWWA Standard C111 shall be supplied as required. Mechanical joint gaskets shall be made of EPDM rubber.

b. **Tapping Valves**

1) Tapping valve interior waterway shall be a full-opening and capable of passing a full-sized shell cutter through the valve. Tapping valve shall be provided with a tapping-flange and flanged joint accessories. Tapping-flanges shall conform to dimensions and drillings of ANSI B16.1, Class 125, ANSI/AWWA C110/A21.10 latest edition, and NAPF 200.

2) Tapping-flange shall have a raised face or lip designed to engage a corresponding recess in a tapping sleeve as defined in MSS SP-60. Mechanical joint accessories shall be provided for mechanical joint end as stated above.

3) All tapping valves shall be interchangeable with multiple makes of tapping sleeves.

4) Mechanical joint gasket shall be made of EPDM rubber.

3. QUALITY CONTROL AND TESTING

a. The resilient seat shall be bubble-tight against a 200-psi water working pressure and maintain zero leakage at all times.

4. MANUFACTURER

Standard valves shall be domestically assembled and shall be:

Clow F-6100; U. S. Pipe Metroseal 250; AVK Series 25;
Mueller Co. (2360 for 2"-12", 2361 for 14"-24"); Kennedy KenSeal 457;
American Flow Control Series 500 or Series 2500; or approved equal.

Tapping valves shall be domestically assembled and shall be equal to or better than:

Clow F-6114; U. S. Pipe Metroseal 250; American AVK Series 25
Mueller Co. (2360 for 2"-12", 2361 for 14"-24"); Kennedy KenSeal 7571;
American Flow Control Series 500 or Series 2500; or approved equal.

2" GATE VALVE, RESILIENT SEAT

1. GENERAL

Resilient Seat Gate Valves (Valves) provided, push-on or threaded joint shall be manufactured in accordance with AWWA C-509 latest edition and as specified herein. The valves described in these technical specifications are to be furnished including accessories.

2. PRODUCT

- a. Valves shall be the non-rising stem type that shall open by turning a 2-inch square AWWA operating nut clockwise, open right.
- b. The wedge shall be bronze manufactured in accordance with ASTM B62. It shall be fully encapsulated with rubber molded in place and bonded in accordance with ASTM D429. The wedge rubber coating shall be ethylene propylene diene (EPDM) rubber. Rubber mechanically attached with screws rivets and similar fasteners shall not be acceptable.
- c. Stems shall be sealed by a minimum of two O-rings; stem seals shall be replaceable with the valve full open and while subjected to full rated pressure.
- d. Low friction torque reduction thrust bearings shall be located both above and below the stem collar.
- e. All bonnet bolts, gland bolts, nuts and other trim hardware exposed to the outside environment shall be stainless. Thrust collar tie-rod bolts shall be stainless steel.
- f. The valve shall be coated inside and out by epoxy coating meeting AWWA C-550, latest edition.
- g. Valve Ends:

- 1) Valve ends for push-on joint valves shall conform to AWWA C-111 latest edition and shall be suitable for use with iron pipe size plastic pipe as well as iron pipe.
- 2) Valve ends for threaded joint valves shall have female iron pipe connections compatible with N.P.T. threads as specified in AWWA C-800.

3. MANUFACTURER

All valves shall be domestically assembled and shall be equal to or better than the following:

- a. Push-on end valves: Clow 6110 (for PVC) / 6100 (for MJ);
- b. Threaded end valves: Clow 6103; Waterous Series 500 – Threaded;
American Flow Control Series 2500; AVK Series 03

GATE VALVE w/HANDWHEELS (OS&Y), RESILIENT SEAT
(4-inch and Larger)

1. GENERAL

- a. Outside stem & yoke (OS&Y) Resilient Seat Gate Valves ("Valves") provided under this specification shall be suitable for installation on ductile iron or cast iron pipe. Valves shall be manufactured in accordance with AWWA C509 (or C515), latest editions, or as specified herein.
- b. Valves shall have flange joints at both ends drilled in accordance with the American National Standard B16.1 for Class 125 cast iron pipe flanges.
- c. Valves shall be operated by a handwheel, with an indicating arrow cast on the rim of the handwheel noting the opening direction.
- d. Valves shall open by turning the handwheel clockwise (open right).
- e. Resilient seats shall be made of EPDM rubber.

2. PRODUCT

- a. Valve stems shall be stainless steel and manufactured in accordance with AWWA C509 (or C515). Stems, stem nuts and wedges shall act independently. Stems shall be sealed by at least two O-ring seals, one located both above and below the thrust collar. Stems shall be provided with low friction torque reducing thrust bearings. Thrust washers may be used to separate the thrust collar from iron surfaces.

City-wide Meter, Hydrant, and Valve Installation and Replacement
Contract 18-C-00030

- b. Valve bodies and gates shall be cast iron or ductile iron manufactured in accordance with ASTM A126 or ASTM A536 respectively, and AWWA C509 (or C515), latest revisions. All internal and external exposed ferrous surfaces of the valve body and gate shall have an epoxy coating applied to a minimum of eight mils, in accordance with AWWA C550 latest edition. Non-metallic resilient seats shall be bonded to the gate, mechanically attached seats will not be accepted. The method of bonding shall be approved by ASTM D429 A or B as specified in AWWA C509. Hollow gates shall be provided with a drain in the bottom to flush the internal cavity of foreign material and stagnant water each time the valve is operated.
- c. Hex-head cover and flange accessory bolts and nuts shall be stainless steel.

3. QUALITY CONTROL AND TESTING

- a. The resilient seat shall be bubble-tight against a 200-psi water working pressure and maintain zero leakage at all times.

4. MANUFACTURER

Valves shall be domestically assembled and shall be equal to or better than Clow F-6136 OS&Y, U.S. Pipe Metroseal 250, or American Flow Control Series 2500-1.

BUTTERFLY VALVES (16" and LARGER)
(Rubber Seated, Mechanical Joint)

1. GENERAL

All Rubber-Seated Butterfly Valves ("Valves") provided shall be manufactured in accordance with AWWA C504, latest edition or as specified herein.

2. PRODUCT

- a. Valves provided shall have a minimum rating of Class 150B. Valve bodies shall be manufactured in accordance with AWWA C504. The mechanical joint of the valves shall be in accordance with ANSI/AWWA C-111/A21.11, latest revision, except as noted herein.
- b. The valve seat shall be located on the valve body or disc and shall provide drip-tight shutoff for pressure differential of 150 psig versus 0 psig in either direction. The seat shall be made of EPDM. For valve seats mounted on the disc, the valve seat shall be vulcanized to a stainless steel seat ring that shall be mechanically attached to the disc with stainless steel bolts. For valve seats mounted on the body, the valve seat shall be bonded to the body and shall meet test procedures as outlined in ASTM D-429 Method A or B. Valve seat mating surfaces shall be 316 Stainless Steel.
- c. The valve shaft shall be a one-piece unit extending completely through the valve disc or may be

City-wide Meter, Hydrant, and Valve Installation and Replacement
Contract 18-C-00030

stub shaft construction for valves 18 inches and above. Shaft materials shall conform to AWWA Standard C-504, Section 3.3, latest revision. Valve shaft shall be 316 Stainless Steel minimum.

- d. The valve disc shall have no external ribs transverse to the flow and shall be constructed of material as specified in AWWA C-504, Section 3.4, latest revision.
- e. Shaft seals shall be standard "O" ring or "V" packing seals, and all seals shall be replaceable without disassembly of the valve.
- f. The operator shall be manual type opening to the right (clockwise). The operator shall be traveling-nut type. All operators shall be totally enclosed, sealed, gasketed and lubricated as specified in AWWA C-504, Section 3.8. The operator shall also be able to apply output torque required to operate the valve under adverse conditions without exceeding input torque as allowed under AWWA Standard C-504. It shall also be capable of withstanding overload input torque of 450 ft. lbs. against the disc stop. Disc stops shall be not in the waterway.
- g. Valve body interior and disc shall have an epoxy protective coating meeting AWWA Standard C-550.
- h. Mechanical joint valves provided shall be designed for buried service.
- i. Mechanical joints shall be in accordance with AWWA Standard C-111, latest revision, with exceptions noted herein. Mechanical joint gaskets provided shall be made of EPDM rubber. The bolts and nuts shall be domestically manufactured of high strength, low alloy steel such as Cor-Ten, Usalloy, ACIPalloy or approved equal.
- j. Mechanical joint valves shall be provided with 2-inch square operating nuts in conformance with AWWA C-500.

3. QUALITY CONTROL AND TESTING

- a. Flow Characteristics - The maximum non-shock shutoff pressure shall be 150 psi.

4. MANUFACTURER

Valves shall be domestically assembled and shall be equal to or better than Valmatic (Series 2100 or 2000), Mueller Linesal III, or approved equal.

INSERTION VALVES (4" to 12")

1. GENERAL

City-wide Meter, Hydrant, and Valve Installation and Replacement
Contract 18-C-00030

Insertion valves shall be installed in live cast iron, ductile iron, C-900 PVC, and asbestos cement pipelines without requiring the shutdown of water flow through the pipe. The design should allow the insertion valve to be installed into an existing pressurized pipeline while maintaining constant pressure and service. Insertion valves provided shall be true resilient seat gate valves that will remain in the water distribution piping system after insertion. Insertion valves must safely operate in balanced and unbalanced pressure situations – pressure equalization on the downstream (or upstream) side of the closed valve shall not be necessary to open the valve.

2. PRODUCT

- a. Insertion valve shall be capable of pressure-tight assembly to the exterior of the pipe in which flow is to be stopped at working pressures up to 250 psi.
- b. Insertion valve shall:
 - 1) have a ductile iron body, bonnet and wedge that provide strength and pressure ratings that meet or exceed the requirements of AWWA C-515 or C-509 Standards.
 - 2) open right (clockwise).
 - 3) be capable of working on Cast/Grey Iron or Ductile Iron Class A B C and D, IPS PVC, C900 and C909 PVC, Steel, AC pipe diameters without changing either top or bottom portion of split valve body.
 - 4) be suitable for working pressures up to 250 psi. The pressure rating designation must be cast into the body of the insertion valve.
 - 5) have stuffing box, operating stem, and resilient wedge that are removable, repairable, and/or replaceable under pressure.
 - 6) have valve body that provides full mechanical protection of the pipe, and that is permanently restrained to the pipe.
 - 7) have a body of two-piece ductile iron casting manufactured to specifications of ASTM A536, latest revision, min. Grade 65-45-12, with 8-mil (min.) epoxy coating inside and out that meets or exceeds ANSI\AWWA C-550 Standards, and is certified to ANSI\NSF 61.
 - 8) have a ductile iron wedge, fully encapsulated with EPDM rubber by high pressure and high temperature compression or injection mold process. There shall be no exposed iron. EPDM rubber shall be ANSI\AWWA NSF-61 certified.

City-wide Meter, Hydrant, and Valve Installation and Replacement
Contract 18-C-00030

- 9) have a wedge that seats on the valve body and not on the pipe. The wedge shall be totally independent of the carrier pipe – it shall not come into contact with the carrier pipe or depend on the carrier pipe to create a seal.
 - 10) have a wedge that rides inside the body channels to maintain wedge alignment throughout its travel control, regardless of high- or low-flow pressure or velocity.
 - 11) the wedge shall be symmetrical and seal equally well with flow in either direction.
 - 12) have gate valve stem and wedge nut made of copper alloy in accordance with Section 4.4.5.1 of AWWA Standard C-515.
 - 13) have a 2” standard (square), NRS (non-rising stem) operating nut in accordance with ASTM A126, Class B.
 - 14) have a NRS stem with integral thrust collar in accordance with Section 4.4.5.3 of AWWA Standard C-515. Two piece stem collars are not acceptable.
 - 15) open and close through AWWA standard turns per inch.
 - 16) have a triple O-ring stem seal with two O-rings located above and one O-ring located below the thrust collar.
 - 17) have mechanical joint (MJ) ends for connection of the valve to the pipeline.
 - 18) the stuffing box, operating stem and resilient wedge (complete bonnet and all moving parts) shall be removable, repairable and/or replaceable under pressure. So that, in the event the valve stem is broken or damaged, the bonnet can be removed under pressure.
- c. All bolting materials shall meet or exceed the physical strength requirements of ASTM A307 with dimensions conforming to ANSI B18.2.1 (304 SS min.).
- d. The sleeve shall be pressure tested prior to cutting the pipe, either through the use of the temporary knife gate installed on the valve body or through a blind flange installed on the valve body, to 150 psi.
- e. The tapping cutter shall extract the coupon from the cut pipeline.

- f. Restraint devices connecting the valve body castings to the pipe shall be split EBAA Mega-lug, or approved equal, with a working pressure rating of 350 psi. Gland body, wedges, and wedge-actuating components shall be cast from Grade 65-45-12 ductile iron material in accordance with ASTM A536. Torque-limiting twist-off nuts shall be included to ensure proper actuating of the gripping wedges. Restraint devices shall be listed by Underwriters Laboratories, and Approved by Factory Mutual.

3. QUALITY CONTROL

- a. Valves shall meet or exceed test specifications as set forth in AWWA C-515, latest revision, excluding in Section 5.1 Testing: 5.1.13 (leakage test), and 5.1.2.3 (seat test).

4. MANUFACTURER

Insertion valves shall be domestically manufactured. Insertion valves shall be Team Industrial Services "Team Insert Valve", or approved equal.

VALVE BOXES
(Class 30 or 35 Grey Iron)

1. GENERAL

Valve boxes provided under this specification shall be designed to provide access to an underground valve 2-inch operating nut at a depth of 2-feet or greater. Valve boxes shall be suitable for installation in areas subject to heavy vehicle traffic loading.

2. PRODUCT

Valve boxes shall include removable valve box cover with "WATER" label as shown on the Standard Dimension detail titled "Valve Box". All valve boxes shall be manufactured of Class 35 grey iron. All valve boxes shall consist of four parts: valve box covers, risers, top sections, and bottom sections. All valve boxes shall be the same dimension, within manufacturing tolerances, as shown in Standard Dimension Detail "Valve Box".

3. MANUFACTURER

Valve box manufacturers shall have a domestic presence. Valve boxes shall be equal to or better than those made by Bingham & Taylor, Union Foundry, Sunshine Foundry, or Pipeline Components, Inc.

LOCATING (TRACER) WIRE BOXES

1. GENERAL

Curb stop boxes ("boxes") shall be provided to house the ends of tracer wires installed along a pipe and shall be installed directly over the pipe the wire is tracing. Tracer wire ends shall terminate in the curb stop box such that they can be accessed and charged to facilitate locating the buried pipe. Boxes installed in roadways shall be suitable for installation in areas subject to heavy vehicle traffic loading (be H-20 rated) and shall have cast iron rims. Boxes installed out of roadway or sidewalk shall be installed within reinforced concrete pads poured around valve boxes per the Standard Details, or in a separate 12"x12" (min.) x 6" reinforced concrete pad.

2. **PRODUCT**

Stop boxes shall include locking lids lettered with "WATER" and shall be blue in color. All stop boxes shall be manufactured of high impact ABS plastic; cast iron roadway rims shall exceed ASTM A-48 Class 30. All stop boxes shall consist of a telescoping top and bottom section, with flared or square bottom to prevent settling or pull out of the box.

3. **MANUFACTURER**

Tracer wire boxes shall be Bingham & Taylor Cathodic Protection Test Boxes (model P200NFG for non-roadway applications, P4HHD for roadway applications), or approved equal.

COMPACT ANCHOR FITTINGS - DUCTILE IRON

1.0 **GENERAL**

Ductile Iron Compact Anchor Fittings ("Fittings") provided under this specification shall be manufactured in accordance with AWWA Standard s C-153 and C-111, latest editions, and as specified herein. Joint accessories shall be provided with fittings.

2.0 **PRODUCT**

a. **Tees**

(1) Both joints on the run of all anchor tees shall be mechanical joint in accordance with AWWA Standard C-111, latest edition.

(2) All mechanical joints shall be supplied with a joint accessories package (bolts, nuts and gasket) as part of the anchor fitting. MJ Gaskets shall be made of EPDM rubber formulated to resist chloramine degradation. All anchor fittings shall be compatible with mechanical joint connections in accordance with AWWA C-111, latest edition, and shall be capable of mechanical restraint so as to eliminate the need for additional thrust restraints.

(3) The standard anchor tee branch shall have an anchoring "plain end" which includes an integral or split follower gland, suitable for connecting to mechanical joint fitting meeting ANSI/AWWA C-111/A 21.11.

b. Anchor Elbow and Anchor Coupling

The Anchor x Anchor elbows and anchor couplings shall have for both ends anchoring "plain ends". These "plain ends" shall have integral or split follower glands, suitable for mechanical joint fittings meeting ANSI/AWWA C-111/A 21.11.

c. Joint Accessories

- (1) All T-head bolts and nuts for joints shall be domestically manufactured high-strength, low-alloy steel such as "Corten", "Usalloy," or "ACIPalloy."
- (2) All joint accessories shall be furnished with anchoring fittings.
- (3) All gaskets shall be EPDM rubber.

All anchoring fittings shall be furnished with either: i) a standard thickness cement mortar lining seal coated in accordance with AWWA Standard C-104, latest edition, and an exterior, asphalt coating which conforms to ANSI/AWWA C-151/A21.51; or, ii) have factory-applied fusion bonded epoxy coatings both inside and outside, in accordance with AWWA C550.

All fittings shall have a minimum pressure rating of 350 psi.

3.0 MANUFACTURER

Ductile iron compact anchor fittings shall be manufactured by U.S. Pipe and Foundry Company, Clow, American Ductile Iron Pipe, McWane, Pipeline Components, Inc. or approved equal.

COMPACT MECHANICAL JOINT FITTINGS-DUCTILE IRON

1. GENERAL

- a. Ductile iron compact mechanical joint fittings shall be manufactured in accordance with ANSI/AWWA C-153/A21.53, latest revisions and the specifications stated herein. Fittings shall be listed by the National Sanitation Foundation (NSF) and shall conform to the requirements of NSF-61.
- b. Whenever the word "fitting" is used in this specification, it shall mean "Compact Ductile Iron Mechanical Joint Fitting".

2. PRODUCT

- a. For fittings larger than 16-inches physical and chemical properties shall be in accordance with ANSI/AWWA C153/A21.53, latest revision. The minimum working pressure for fittings shall

be 350. The minimum wall thickness shall not be less than that of pressure class 350 ductile iron pipe.

- b. Joints shall be Mechanical Joint in accordance with ANSI/AWWA C111/A21.11 and C153/A21.53, latest revision, with exceptions noted herein. Mechanical Joint bolts and nuts shall be domestically manufactured of high-strength, low-alloy steel such as "Corten", "Usalloy", or "ACIPalloy". Joints requiring a shorter bolt than called for in ANSI/AWWA C111/A21.11 shall be supplied as required. Gaskets for mechanical joints shall be made of ethylene propylene diene (EPDM) rubber.
- c. Exterior Coating and Interior Lining

Mechanical Joint fittings furnished shall have either of the exterior coating and interior lining systems described below:

- (1) Cement Mortar Lining: Fittings furnished shall have a standard thickness cement mortar lining and be seal coated in accordance with ANSI/AWWA C-104/A21.4, latest revision. Fittings shall be listed by an approved certifying agency as conforming to all requirements of ANSI/NSF 61 and shall have an asphalt exterior coating which conforms to ANSI/AWWA C-153/A21.53.
- (2) Fusion-bonded Epoxy: Fittings shall be coated inside and out with fusion-bonded epoxy, and be in conformance with the requirements of ANSI/AWWA C-116/A21.16 and AWWA C-550, latest revisions. Fittings shall be listed by NSF or by an approved certifying agency as conforming to all requirements of ANSI/NSF 61.

3. MANUFACTURER

All manufacturers of ductile iron compact MJ fittings specified herein shall have a domestic presence. The fittings shall be manufactured by U.S. Pipe, Clow, Tyler/Union Pipe, American Ductile Iron Pipe, McWane, Pipeline Components, Inc., Sigma, Star Pipe, or approved equal.

FLANGED FITTINGS (Standard Class 125)

1. GENERAL

All standard class 125 flanged fittings shall be manufactured in accordance with ANSI/AWWA Standard C-110/A21.10 and NAPF 200, latest revision.

2. PRODUCT

- a. Standard class 125 flanged fittings shall have a minimum pressure rating of 250 psi. Flanges shall be round type, faced and drilled and shall conform to ANSI B16.1 for cast-iron or bronze pipe flange Class 125.

- b. The joints shall be flanged in accordance with ANSI/AWWA C-110/A21.10 and NAPF 200, latest revision. All necessary hex-head bolts and nuts, and full-faced gaskets for each joint shall be furnished as a Flange Accessory Package and shall conform to ANSI B18.2.2; threads shall be manufactured in accordance with ANSI B1.1. Bolts and nuts shall be high-strength, low-alloy steel such as "Corten", "Usalloy", or "ACIPalloy". Bolt circle and bolt holes shall be drilled and faced to match American National Standard Institute (ANSI) B16.1, Class 125 Flanges.
- c. All standard class 125 flanged fittings shall have a standard thickness cement mortar lining and shall be seal coated in accordance with AWWA Standard C-104, latest revision.

3. **MANUFACTURER**

Standard class 125 flanged fittings shall be manufactured by U.S. Pipe and Foundry Co., American Ductile Iron Pipe, PCI, Tyler-Union, Sigma, or approved equal.

OFFSETS
(Ductile Iron, Mechanical Joint)

1. **GENERAL**

All ductile iron mechanical joint offsets shall be of ductile iron and manufactured in accordance with and ANSI/AWWA Standards C-110/A21.10 (or C-153/A21.53) and C-111/A21.11, latest revisions.

2. **PRODUCT**

- a. Ductile iron mechanical joint offsets shall have a minimum pressure rating of 350 psi.
- b. Joints shall be mechanical joints in accordance with C-111/A21.11, latest revision. All joint accessories shall be furnished with the fittings. Mechanical joint bolts and nuts shall be domestically manufactured of high-strength, low-alloy steel such as "Corten", "Usalloy", or "ACIPalloy". The follower gland shall be manufactured from ductile iron. The gasket shall be made of EPDM rubber.
- c. Mechanical Joint fittings furnished shall have either of the exterior coating and interior lining systems described below:
 - (1) Cement Mortar Lining: Fittings furnished shall have a standard thickness cement mortar lining and be seal coated in accordance with ANSI/AWWA C-104/A21.4, latest revision. Fittings shall be listed NSF or by an approved certifying agency as conforming to all requirements of ANSI/NSF 61 and shall have an asphalt exterior coating which conforms to ANSI/AWWA C-110/A21.53.
 - (2) Fusion-bonded epoxy: Fittings shall be coated inside and out with a minimum 8 mils of

fusion-bonded epoxy, and be in conformance with the requirements of ANSI/AWWA C-116/A21.16 and AWWA C-550, latest revisions. Fittings shall be listed by an approved certifying agency as conforming to all requirements of ANSI/NSF 61.

3. MANUFACTURER

Ductile iron mechanical joint offsets shall be manufactured by U.S. Pipe and Foundry Co., American Ductile Iron Pipe, Sigma, Tyler-Union, Union Foundry, or approved equal.

MECHANICAL JOINT BOLTS-AND-NUTS

1. GENERAL

All mechanical joint bolts and nuts shall be manufactured in accordance with ANSI/AWWA C-111/A21.11, latest revision, and shall also adhere to the following specification.

2. PRODUCT

- a. All mechanical joint bolts shall be a Tee-head design with hexagonal nuts. Dimensions shall be in accordance with ANSI/AWWA C-111/A21.11.
- b. All bolts and nuts shall be manufactured of high-strength, low alloy steel in conformance with ANSI/AWWA C-111/A21.11 and ASTM A242, latest revisions.
- c. All bolts shall be designed for internal and external threads to conform to ANSI/ASME B1.1 and B1.2. Thread form shall conform to the standards and dimensions of the coarse-thread series Unified Coarse (UNC); external threads shall be made in compliance with Class 2A limits, and internal threads shall be made in compliance with Class 2B limits. The Contractor is advised that various HDPE MJ adapters may require longer than standard bolts to complete the installation.

3. MANUFACTURER

Mechanical joint bolts and nuts specified herein shall be domestically manufactured of Cor-Ten or approved equal by Birmingham Foundry, National Set Screw Corporation or approved equal.

SOLID SLEEVES
(Ductile Iron, Compact, MJ)

1. GENERAL

Solid sleeves shall be used to join two plain ends of pipe or repair a damaged pipe.

2. PRODUCT

City-wide Meter, Hydrant, and Valve Installation and Replacement
Contract 18-C-00030

- a. Solid sleeve lengths shall be up to 24-inches. The solid sleeve shall be capable of having two plain ends of pipe inserted into opposite ends of the sleeve. The sleeve is then to be sealed to the pipe by a mechanical joint at each end of the sleeve.
- b. All sleeves shall be manufactured of ductile iron. Solid sleeves shall be manufactured in accordance with ANSI/AWWA Standard C-153/A21.53, latest revision. All sleeves shall be rated for a minimum working pressure of 350 psi.
- c. All solid sleeve sealing ends shall be mechanical joints in accordance with ANSI/AWWA C-111/A21.11, latest revision. All joint accessories shall be furnished with the fittings. All bolts and nuts shall be made of high-strength, low-alloy steel such as "Corten", "Usalloy", or "Acipalloy". The gasket shall be for a standard Mechanical Joint, in accordance with ANSI/AWWA C-111/A21.11, latest revisions, and be made of EPDM rubber. The follower gland shall be manufactured from ductile iron at least ASTM A536, Grade 70-50-05 in accordance with ANSI/AWWA C-111/ A21.11, latest revision
- d. All ductile iron compact solid sleeves shall be furnished with a standard thickness cement mortar lining and seal coating in accordance with AWWA Standard C-104, latest revision.
- e. Fittings shall have an exterior, asphaltic coating which conforms to ANSI/AWWA C-153/A21.53.

3. MANUFACTURER

All ductile iron mechanical joint solid sleeves shall be manufactured by U.S Pipe, Sigma, Tyler/Union, American Cast Iron Company, Clow, or approved equal.

DRY-BARREL FIRE HYDRANTS

1. GENERAL

All non-rising stem dry-barrel hydrants shall be manufactured in accordance with AWWA C-502, latest revision and these specifications.

2. PRODUCT

- a. Hydrants shall have a 5¼-inch main valve opening. The main valve shall be of compression-design and shall open against and closing with pressure. The hydrant shall comply with the requirements of Associates Factory Mutual Insurance Companies and have the "FM" symbol cast into the barrel. The hydrant shall be listed with Underwriter's Laboratories. Hydrants shall open by turning the operating nut counterclockwise.
- a. The hydrant shall be provided with a breakable traffic feature designed so that the nozzle section of the hydrant can be rotated a full 360 degrees. Break couplings shall be made of cast

City-wide Meter, Hydrant, and Valve Installation and Replacement
Contract 18-C-00030

iron, epoxy coated steel, or forged stainless steel. The lower barrel and shoe shall be made of ductile iron, manufactured in accordance with AWWA C-502, latest revision.

- b. All hydrants shall have two 2½-inch bronze nozzles, 180 degrees apart, and one 4½-inch bronze nozzle. All nozzle centerlines shall be at the same elevation. Nozzle outlet threads to be National Standard fire hose coupling screw thread, as described in Appendix A of AWWA C-502. After being coated with an approved anti-seize compound as specified herein, hydrant nozzle shall thread or twist-lock into the hydrant nozzle section; a locking device secures the nozzle. Cast iron or ductile iron nozzle caps provided, with gaskets; nozzle cap nut configuration matches hydrant operating nut. Chains are not provided on nozzle caps.
- c. Hydrant design shall be such that removal of the seat valve drain mechanism, internal rod and all working parts can be accomplished through the top of the hydrant without disturbing the ground-line joint or nozzle section. The shoe inlet shall be mechanical joint, in accordance with AWWA C-111, latest revision. The interior of the shoe and (and upper and lower valves plates, if utilized in design) shall be epoxy-coated in accordance with AWWA C550, latest revision. Accessory kits shall be provided with MJ bolts and nuts and gasket. Mechanical joint nuts and bolts to be manufactured of high-strength, low-alloy steel equal to or better than "Cor-Ten". Main valve gasket and mechanical joint (MJ) gasket made of EPDM.
- d. All above-ground external bolts, studs, and nuts made of low-zinc bronze or stainless steel. Below-ground bolts, studs and nuts shall be made of high-strength, low-alloy steel as specified herein, or of stainless steel. When bolts are used at the break coupling, they shall not be frangible.
- e. Unless the operating rod is made of stainless steel, the rod shall be sheathed where it passes through a double o-ring seal, sealing the operating threads from the water in the hydrant at all times when the valve is in the open or closed position. Another o-ring shall prevent water from passing between the operating shaft and the sheath. Downward travel of the operating rod and valve assembly shall be controlled by a travel stop device (located in the bonnet only), to prevent the bottom of the main valve from making contact with the epoxy coating of the shoe. Travel stop devices located on the bottom of the operating rod are not acceptable. Bronze operating nuts shall be fully covered with a cast iron or ductile iron weather shield and shall have at least one anti-friction thrust washer to reduce the operating torque when opening the hydrant. The hydrant's bronze main valve seat ring shall thread into a bronze sub-seat or drain ring. The drain outlet for the hydrant shall be eliminated as part of the casting or machining process.
- f. Hydrant operating threads shall be lubricated with anti-seize compound paste upon assembly. Approved anti-seize compounds are Bostik Never-Seez food-grade (888-603-8558), or Permatex part #82448 (food-grade anti-seize compound). (877-376-2839), or MobilGrease FM102 (food-grade). Approval for other anti-seize compounds shall be requested in writing to the Tampa Water Department, accompanied with a Material Safety Data Sheet from the manufacturer of the compound for review. Anti-seize compound shall not contain any heavy

metals.

- g. When the hydrant is tested for head-loss as described in AWWA C502, Section 5, latest revision, the maximum head-loss shall not exceed 2.5 psi when flowing at 1000 gpm through the 4 ½-inch nozzle,.
- h. Hydrant coatings shall be as specified in AWWA C502 Section 4.02. Additionally, above-ground exterior hydrant coatings shall be minimum 4 mil Dry Film Thickness white primer coating, compatible with Porter high-grade enamel final paint to be applied in the field.
- i. If manufacturer uses locking keys to secure the lower barrel to the shoe, all locking keys to be fully coated with a Water Department approved anti-seize compound applied upon assembly

4. MANUFACTURER

- a. Hydrants shall be assembled and tested in their entirety within the United States of America or its territories. The manufacturer of hydrants shall have continuously manufactured, catalogued, sold, and had in service the hydrants in the size proposed for a minimum of five years.
- b. Hydrants shall be:
 - American (Darling B-84-B 5¼); U.S. Pipe (Metro 250 M94, 5 ¼);
 - Kennedy (Guardian K81-D, 5¼); or American AVK (Series 2780, Nostalgic, 5¼).

TAPPING SLEEVES (Mechanical Joint)

1. GENERAL

Tapping sleeves (mechanical joint) shall be constructed of ductile iron. All tapping sleeves shall be suitable for tapping cast iron, ductile iron pipe, C-900 PVC pipe, and all pipe manufactured in accordance with ANSI A21 Standard, AWWA, and these specifications.

2. PRODUCT

- a. Tapping sleeves shall be of the split sleeve design; one half shall contain the outlet hub, gasket, and tapping flange; the other shall form the back of the sleeve. A ¾" NPT test plug shall be provided on the outlet throat of the sleeve for pressure testing the sealed sleeve at 150 psi prior to tapping the pipe. All tapping sleeves shall allow a full-size cutting head to pass through the outlet of the hub.
- b. Tapping sleeves shall be constructed of ductile iron manufactured in accordance with ASTM A536.
- c. All bolts and nuts joining the two halves of the sleeve shall be high strength, low alloy steel,

such as Cor-Ten, in accordance with AWWA C-111, latest revision.

- d. Tapping sleeve connection flanges shall conform to AWWA C-110/ANSI B16.1 Class 125 with counter bore per MSS SP-60 dimensions.
- e. Mechanical joint tapping sleeves shall form a mechanical joint at each end of the sleeve after bolting the halves together. The sleeve shall then be sealed to the pipe by assembling the mechanical joint using split gaskets and follower glands.
- f. All ductile iron sleeves shall have an outside bituminous coating in accordance with AWWA C-110, latest revision.
- g. End and side gaskets shall be made of EPDM rubber.

3. **MANUFACTURER**

Tapping sleeve (mechanical joint) shall be domestically assembled. Tapping sleeves (mechanical joint) shall be manufactured by U.S. Pipe Mechanical Joint Tapping Sleeve, Mueller Co. H-615, American Flow Control or approved equal.

TAPPING SLEEVES (Steel, "O-Ring" Type)

1. **GENERAL**

Tapping sleeves (steel/"O-ring" type) shall be constructed of high strength steel manufactured in accordance with ASTM A285. Steel tapping sleeves shall be suitable for tapping ductile iron pipe, C-900 PVC pipe, and all pipe manufactured in accordance with ANSI A21 Standards, AWWA, and these specifications.

2. **PRODUCT**

- a. All tapping sleeves (steel or "O-ring" type) shall be split sleeve design; one half shall contain the outlet hub, gasket and tapping flange; the other half shall form the back. A ¾" NPT test plug shall be provided on the outlet throat of the sleeve for pressure testing the sealed sleeve at 150 psi prior to tapping the pipe. All tapping sleeves shall allow a full-size cutting head to pass through the outlet of the hub.
- b. All bolts and nuts joining the two halves of the sleeve shall be high strength, low alloy steel, such as Cor-Ten, in accordance with AWWA C-111, latest revision.
- c. All tapping sleeve connection flanges shall be a Class 125 flanged joint, conforming to AWWA C207 Class D, ANSI 150 lb. with a counter bore per MSS SP-60 dimensions.
- d. Tapping sleeves shall seal to the pipe by the use of a confined "O-ring" gasket around the tap

opening between the sleeve and pipe or by a full circumferential gasket between the sleeve and pipe. Gasket shall be made of EPDM rubber.

- e. All steel tapping sleeves shall be finished with fusion-bonded epoxy coating both inside and outside, in accordance with AWWA C-550, latest revisions.

3. MANUFACTURER

Tapping sleeve (steel/"o-ring" type) manufactures shall be domestically assembled. Tapping sleeves (steel/"o-ring" type) shall be: JCM 412, Smith Blair 622, Ford Meter Box FTSC, Dresser 610, Mueller H615, U.S. Pipe T9, or approved equal.

LINE STOPS (4"-36")

1. GENERAL

Line stops shall be used to isolate sections of water mains in order to keep customers in service during water main tie-ins, water main repairs and to compensate for broken valves. The water mains shall remain under pressure during the installation and use.

Line stops shall be constructed of ductile iron or stainless steel (carbon steel is acceptable subject to Engineer approval). All line stop bodies shall be suitable for tapping cast iron, asbestos cement pipe (12" and smaller), ductile iron pipe, C-900 PVC pipe, and all pipe manufactured in accordance with ANSI A21 Standard, AWWA, and these specifications. Line stops on asbestos cement pipe, on pipe greater than 8" and on pipe with taps the same size shall be mechanical joint.

Line stops (steel/"O-ring" type) shall be constructed of high strength steel and shall be manufactured in accordance with ASTM A285. Line stops shall be suitable for tapping ductile iron pipe, C-900 PVC pipe, and all pipe manufactured in accordance with ANSI A21 Standards, AWWA, and these specifications.

2. PRODUCT

- a. Line stop fitting shall be full encirclement, pressure retention type split tee. It shall consist of two segments – an upper flange saddle plate and a lower saddle plate. All bodies shall have a 3/4" NPT test plug to verify all seals are secure prior to tapping. Cover plate gasket shall be EPDM. Completion plug o-ring shall be EPDM. Gasket shall be molded from elastomer compounds that resist compression setting and are compatible with water in the 32 to 120 deg. F temperature range.
- b. Line stop sleeve shall have a full-circle rubber gasket and a flanged outlet for bolting to the line stop tapping valve. Sealing may be accomplished by either split end gaskets and mechanical joint ends or a single rubber gasket around the tap opening.

- c. Nuts-and-bolts shall be stainless steel.
- d. Outlet flange shall be ductile iron, stainless steel, or machined from a 150 lb. forged steel flange (ASTM A181 or A105) or from pressure vessel quality steel plate (ASTM A285, Grade C), be flat-faced and drilled per ANSI B16.5

4. MANUFACTURER

Line stops shall be domestically assembled equivalent to or better than Advanced Valve Technologies EZ Valve II, Hydra-Stop, JCM 440 Line Stop, or approved equal.

SERVICE SADDLES

1. GENERAL

Service saddles shall be used for tapping water distribution pipes to provide a drip-tight connection to the main for customers' water meters. Service saddles shall incorporate a wrap-around type body, straps, gasket and bolts. When installed, the body shall wrap around the main for a minimum of 160 degrees.

2. PRODUCTS

- a) Service saddle for pipe less than 3-inches shall be single band which is hinged or split from the saddle body and is anchored by bolting one or more bolts between the band and saddle body, or a double strap design anchored by four bolts.
- b) Service saddles for pipe equal to or greater than 3-inches shall use a double-wide single flexible band or a double strap with a minimum of a four bolt pattern anchoring. These service saddles shall provide for a variable range in diameter per nominal size of pipe, yet shall fit the stated diameter for the nominal size pipe noted.
- c) Service saddles shall be constructed from bronze, ductile iron in accordance with ASTM A536, or stainless steel and shall seal to the distribution pipe by an EPDM rubber gasket. The gasket shall maintain a resilient seal without cracking or becoming brittle during the working life of the service saddle. All service saddles shall have corporation tap threads.
- d) Threads shall be AWWA CC in accordance with AWWA C-800.
- e) Gasket shall be of self-sealing design.
- f) Service saddle bodies shall be protected with a heavy coating of corrosion resistant, metal primer.
- g) Service saddles provided shall be suitable for use with water of 100 degrees Fahrenheit and pressure up to 150 psi without rupture and failure.

h) Straps and bolts shall be carbon steel conforming to ASTM A108, electro-galvanized with dichromate seal.

3. MANUFACTURER

Service saddles for 2-inch or less pipe and 3-inch or greater pipe shall be as follows:

- i. 2-inch or less:

Clow 3401;	Ford 570/590;	JCM 401/402/403/405 (DI);
Jones J-995;	Rockwell 313/317	Ford FS-/ FC-202; F101/202
Smith Blair 311	Mueller H-13420/10475-76	

- ii. 3-inch or greater:

Smith Blair 311	Clow 3408/3410	Ford FS- or FC-202 series
Mueller H-105XX series		Rockwell 313 (DI) /317/323
JCM 402 cortin strap (for DIP)		JCM 406 (for PVC)
Cascade C-S22/CDS2/CNS2/CSC2		

or approved equal.

ASPHALTIC CONCRETE

1. GENERAL

All asphaltic concrete shall satisfy the requirements of the appropriate regulatory agency having jurisdiction over the affected roadway.

2. PRODUCT

- a. Superpave Asphaltic Concrete shall satisfy all provisions of the FDOT Standards for Road and Bridge Construction, Section 334, latest edition.
- b. All Type S Asphaltic Concretes shall satisfy all provisions of FDOT Standards for Road and Bridge Construction Section 331, 2000 Edition.
- c. Superpave Asphalt Base Courses shall satisfy all provisions of the FDOT Standards for Road and Bridge Construction Section 234, latest edition.
- d. All Asphalt Base Courses shall satisfy all provisions of FDOT Standards for Road and Bridge Construction Section 280, 2000 Edition.

3. QUALITY CONTROL AND TESTING

City-wide Meter, Hydrant, and Valve Installation and Replacement
Contract 18-C-00030

The Contractor will be responsible for providing copies of all necessary plant production tests. The City will be responsible for providing all initial field performance testing in accordance with the aforementioned specifications. The Contractor will be responsible for retesting of any failed sections.

BASE MATERIAL

1. GENERAL

All base material shall satisfy the requirements of the regulatory agency responsible for overseeing that portion of the right-of-way.

2. PRODUCT

- a. Shell material shall satisfy all requirements of Section 913, Shell Material, of the Florida Department of Transportation Standard Specifications for Road and Bridge Construction, latest edition, except that testing requirements shall be in conformance with the requirements of the regulatory agency responsible for overseeing the roadway.
- b. Limerock base shall satisfy all requirements of Section 911, Limerock Material for Base and Stabilized Base, of the Florida Department of Transportation Standard Specifications for Road and Bridge Construction latest edition, except that testing requirements shall be in conformance with the requirements of the regulatory agency responsible for overseeing the roadway.
- c. Crushed concrete base shall satisfy all requirements of Section 204, Graded Aggregate Base, of the Florida Department of Transportation Standard Specifications for Road and Bridge Construction 2000 Edition, except that testing requirements shall be in conformance with the requirements of the regulatory agency responsible for overseeing the roadway.
- d. Superpave Asphalt Base Courses shall satisfy all provisions of Section 234, Superpave Asphalt Base, of the Florida Department of Transportation Standard Specifications for Road and Bridge Construction latest edition, except that testing requirements shall be in conformance with the requirements of the regulatory agency responsible for overseeing the roadway.
- e. Asphalt Base Courses shall satisfy all provisions of Section 280, Asphalt Base Courses, of the Florida Department of Transportation Standard Specifications for Road and Bridge Construction 2000 Edition, except that testing requirements shall be in conformance with the requirements of the regulatory agency responsible for overseeing the roadway.

3. QUALITY CONTROL AND TESTING

The Contractor will be responsible for providing copies of all initial materials tests to establish conformance to the contract documents. The City will be responsible for providing all initial field performance testing in accordance with the aforementioned specifications. The Contractor will be responsible for retesting of any failed sections.

TAMPA WATER DEPARTMENT

STANDARD CONSTRUCTION DETAILS LIST

DESCRIPTION:	DETAIL No.
Restoration within FDOT Roadway, Flexible Pavement.....	2.00 A
Restoration within FDOT Roadway, Rigid Pavement	2.00 B
Trenching, Bedding and Backfill for Non Pervious Areas	2.01
Trenching, Bedding and Backfill for Pervious Areas.....	2.02
Jack and Boring for Pavement Crossing.....	2.03
Jack and Boring for Railroad Crossing	2.04
Polyethylene Encasement Installation	2.05
Reinforced Concrete Shock Pad for Cover Less Than 2.5 Feet.....	2.06
Thrust Blocks for Bends	2.07
Thrust Blocks for Plugs	2.08
Thrust Blocks for Tees	2.09
Precast Concrete Thrust Block	2.10
Restrained Joint Standard for Bends, Plugs and Caps	2.11
Restrained Joint Standard for Tees and Reducers.....	2.12
Deadman Thrust Block.....	2.12 A
Tapped Connection from DIP, CIP or PVC Pipe to Water Mains Less Than 4 inches.....	2.13
Automatic Air Release Valve.....	2.14
Automatic Air Vacuum – Air Release Valve.....	2.14 C
Pedestal for Automatic Air Release Valve	2.15
Blow Off Valve Assembly – with 2” PVC or HDPE Pipe	2.16
Blow Off Valve Assembly – with Greater Than 4” DIP, CIP or PVC Pipe.....	2.17
Blow Off Valve Assembly – with 4” or 6” DIP, CIP or PVC Pipe.....	2.17 A
Temporary Sample Tap Installation – with DIP, CIP or PVC Pipe.....	2.18

DESCRIPTION:	DETAIL No.
Temporary Sample Tap Installation for end of line – with DIP, CIP or PVC Pipe.....	2.19
Valve Installation with Valve Box and Pad for DIP and CIP	3.01
Valve Installation with Valve Box and Pad for Plastic Pipe.....	3.02
Butterfly Valve Installation with Valve Box and Pad	3.03
Valve Box – Slip Type	3.04
Valve Box Adjustments for Grade Change	3.05
Valve Box Concrete Collar	3.06
Fire Hydrant Installation	4.01
Fire Hydrants - Methods of Installation	4.02
Tapping Detail for ¾”, 1”, 1 ½”, and 2” DIP, CIP or PVC Pipe.....	5.01
Single Meter Set for ¾”, 1”, 1 ½” or 2” Size Meter	5.02
Dual Meter Set for ¾” and 1” Size Meters	5.03
Single and Dual Meter Service – Short Side for ¾”, 1”, 1 ½” and 2” Size Meters	5.04
Single and Dual Meter Service – Long Side for ¾”, 1”, 1 ½” and 2” Size Meters.....	5.05
Double Detector Check Valve Assembly, 2” – in Meter Box.....	5.09
Meter Box and Cover, Single Service for ¾” or 1” HDPE Services	5.10 A
Meter Box and Cover, Dual Service for ¾” or 1” HDPE Services.....	5.11 A
Meter Box and Cover, Single Service for 1 ½” or 2” HDPE Services	5.12 A
Meter Box and Cover, 13” x 24” with 4 Mouse Holes	5.13
Turbine Meter with Strainer – Above Ground	6.01
Double Detector Check Valve Assembly – Above Ground.....	6.02
Double Detector Check Valve Assembly and Turbine Meter – Above Ground	6.02 B
Pipe Supports for Above Ground Double Detector Check Valve Assembly.....	6.03
Turbine Meter – In Vault.....	6.04
Double Detector Check Valve Assembly – In Vault.....	6.05
Double Detector Check Valve Assembly with 3” and Greater Domestic Meter – In Vault	6.06
Vault Construction for Large Meters and Double Detector Check Valve Assemblies	6.07

DESCRIPTION	DETAIL No.
Vault Construction – Vault Concrete Slab.....	6.08
Turbine Meter with Strainer – In Above Ground Vault.....	6.09
Double Detector Check Valve Assembly – In Above Ground Vault.....	6.10
Fire Line Service and Greater Than 3” Domestic Meter – In Above Ground Vault	6.11
Above Ground Vault – Cross Section	6.12
By-Pass Line, 2”	6.13
Pipe Bedding and Trench for PVC Pipe.....	7.01
Double Copper Tracer Wire on Pipe.....	7.02
HDPE Pipe to MJ Fitting Transition	8.01
HDPE Pipe to DIP / PVCP Spigot to Spigot Connection	8.02
Tapped Connection for Less Than 4” Water Main to HDPE Water Main	8.03
Blow Off Valve Assembly on Greater Than 4” HDPE Pipe.....	8.04
Temporary Sample Tap Installation with HDPE Pipe	8.05
Temporary Sample Tap Installation for End of Line with HDPE Pipe.....	8.06
Valve Setting with HDPE Pipe	8.07
Tapping HDPE Pipe for 1” and 2” Services	8.08
Single and Dual Meter Service with HDPE pipe – Short Side for ¾”, 1”, 1 ½” and 2” Size Meters...	8.09
Single and Dual Meter Service with HDPE pipe – Long Side for ¾”, 1”, 1 ½” and 2” Size Meters ...	8.10

DETAIL FOR RESTORATION WITHIN FDOT ROADWAY

(DETAILS MODIFIED FROM FDOT DESIGN STANDARDS INDEX 307, LATEST EDITION)

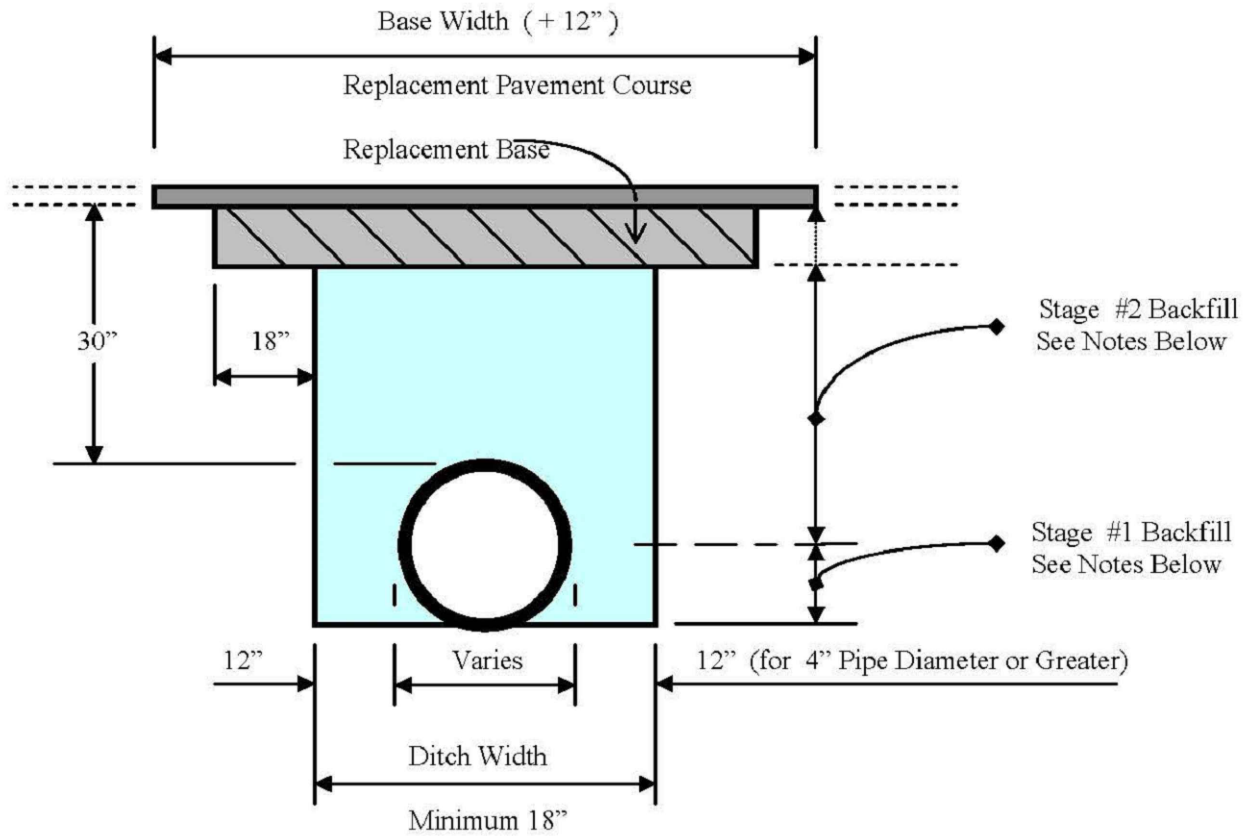

FLEXIBLE PAVEMENT NOTES:

PAVEMENT SHALL BE MECHANICALLY SAWED.

PAVEMENT, BASE, AND BACKFILL MATERIAL SHALL BE PLACED IN ACCORDANCE WITH **CITY OF TAMPA PAVEMENT RESTORATION REQUIREMENTS, LATEST STANDARD SPECIFICATIONS.**

IN STAGE #1, CONSTRUCT COMPACTED FILL BENEATH THE HAUNCHES OF THE PIPE, USING MECHANICAL TAMPS SUITABLE FOR THIS PURPOSE. THIS COMPACTION APPLIES TO THE MATERIAL PLACED BENEATH THE HAUNCHES OF THE PIPE AND ABOVE ANY BEDDING.

IN STAGE #2, CONSTRUCT COMPACTED FILL ALONG SIDES OF THE PIPE AND UP TO THE BOTTOM OF THE BASE. COMPACT MATERIAL USING MECHANICAL TAMPS SUITABLE TO ACHIEVE DENSITY MEETING 98% OF AASHTO T-180, LIFTS NOT TO EXCEED 12" COMPACTED.

IF MECHANICAL COMPACTION IS DIFFICULT TO ACHIEVE, THEN FLOWABLE FILL MAY BE USED. IN STAGE #1, PLACE FLOWABLE FILL MIDWAY UP ON BOTH SIDES OF THE UTILITY. ALLOW TO HARDEN BEFORE PLACING STAGE #2. IF A METHOD IS PROVIDED TO PREVENT FLOATATION FROM OCCURRING, STAGE #1 AND #2 CAN BE COMBINED, IF APPROVED BY THE ENGINEER.

NOTE: SPECIFICATION STANDARDS AND REQUIREMENTS NOT ILLUSTRATED SHALL MEET LATEST FDOT STANDARD SPECIFICATIONS.

TAMPA WATER DEPARTMENT	APPROVED Aug. 2017 _____	REVISED _____ _____ _____	STANDARD DETAILS FOR RESTORATION WITHIN ROADWAY	2.00A
------------------------------	------------------------------------	--	---	-------

DETAIL FOR RESTORATION WITHIN FDOT ROADWAY

(DETAILS MODIFIED FROM FDOT DESIGN STANDARDS INDEX 307, LATEST EDITION)

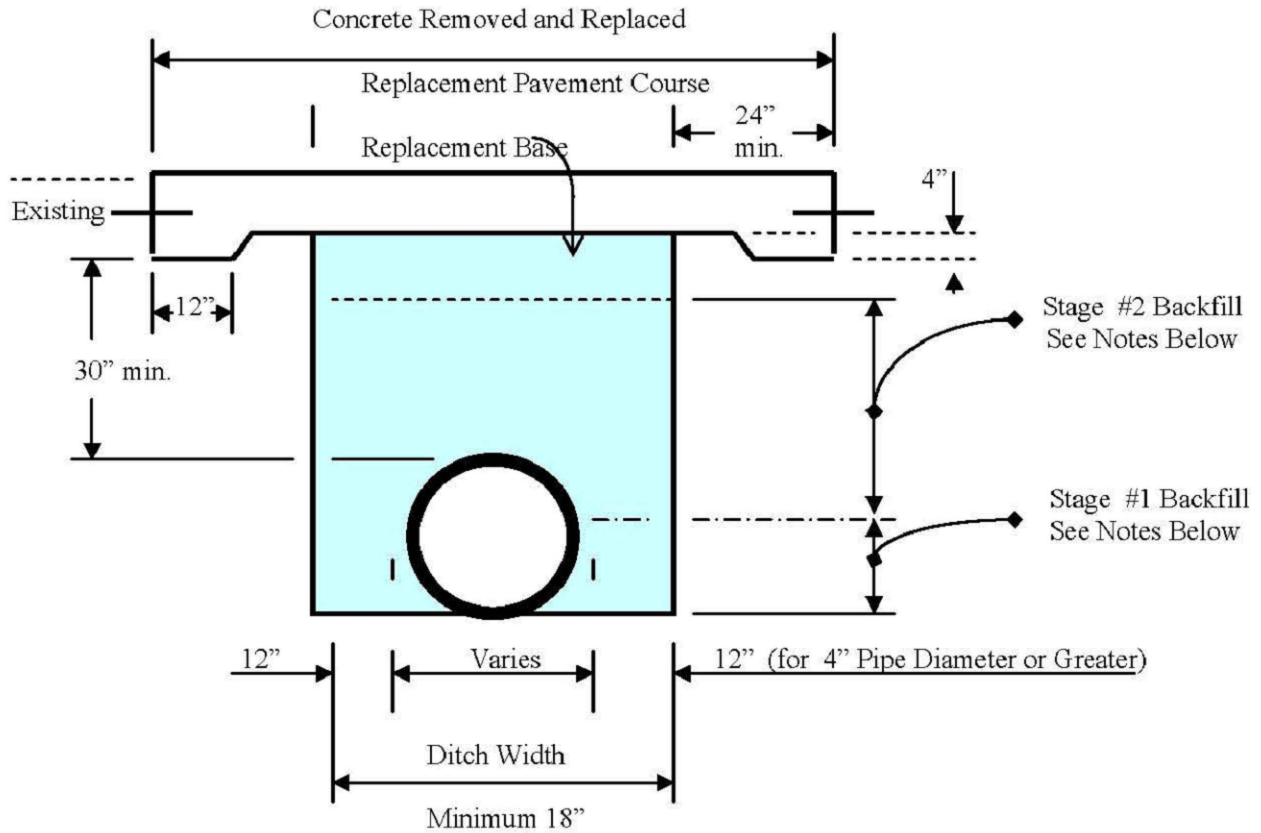

RIGID PAVEMENT NOTES:

PAVEMENT SHALL BE MECHANICALLY SAWED AND RESTORED TO CONFORM WITH EXISTING PAVEMENT JOINTS.

HIGH EARLY STRENGTH CEMENT CONCRETE (3000 PSI) MEETING WITH REQUIREMENTS OF FDOT STANDARD SPECIFICATION 346, LATEST EDITION SHALL BE USED FOR RIGID PAVEMENT REPLACEMENT.

PAVEMENT, BASE, AND BACKFILL MATERIAL SHALL BE PLACED IN ACCORDANCE WITH **CITY OF TAMPA PAVEMENT RESTORATION REQUIREMENTS, LATEST STANDARD SPECIFICATIONS.**

IN STAGE #1, CONSTRUCT COMPACTED FILL BENEATH THE HAUNCHES OF THE PIPE, USING MECHANICAL TAMPS SUITABLE FOR THIS PURPOSE. THIS COMPACTION APPLIES TO THE MATERIAL PLACED BENEATH THE HAUNCHES OF THE PIPE AND ABOVE ANY BEDDING.

IN STAGE #2, CONSTRUCT COMPACTED FILL ALONG SIDES OF THE PIPE AND UP TO THE BOTTOM OF THE BASE. COMPACT MATERIAL USING MECHANICAL TAMPS SUITABLE TO ACHIEVE DENSITY MEETING 98% OF AASHTO T-180, LIFTS NOT TO EXCEED 12" COMPACTED.

IF MECHANICAL COMPACTION IS DIFFICULT TO ACHIEVE, THEN FLOWABLE FILL MAY BE USED. IN STAGE #1, PLACE FLOWABLE FILL MIDWAY UP ON BOTH SIDES OF THE UTILITY. ALLOW TO HARDEN BEFORE PLACING STAGE #2. IF A METHOD IS PROVIDED TO PREVENT FLOATATION FROM OCCURRING, STAGE #1 AND #2 CAN BE COMBINED, IF APPROVED BY THE ENGINEER.

NOTE: SPECIFICATION STANDARDS AND REQUIREMENTS NOT ILLUSTRATED SHALL MEET LATEST FDOT STANDARD SPECIFICATIONS.

TAMPA WATER DEPARTMENT	APPROVED Aug. 2017	REVISED ____ _ ____ _ ____ _	STANDARD DETAILS FOR RESTORATION WITHIN ROADWAY	2.00B
------------------------------	---------------------------	---	---	-------

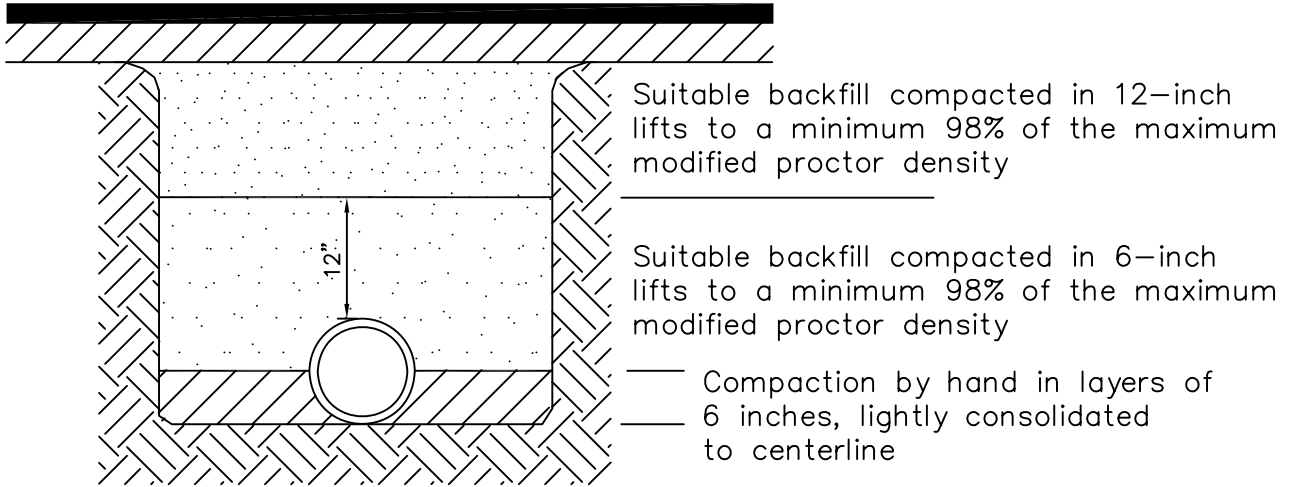

NOTES:

1. Type 2 trench is defined as a flat-bottom trench. Lightly consolidate backfill to centerline of pipe.
2. This standard shall be utilized in the absence of specific standards. The standard of the agency controlling the Right-of-Way shall govern unless otherwise directed by the Engineer.
3. Suitable backfill shall be defined as material free from cinders, ashes, refuse, clay, organic matter, boulders, rocks or stones, or other material that in the opinion of the Engineer is unsuitable.
4. Non-pervious areas shall mean any concrete or asphalt curb, sidewalk, trail, driveway, or roadway.

<p>TAMPA WATER DEPARTMENT</p>	<p>APPROVED <u>Sept. 2011</u></p>	<p>REVISED _____ _____ _____</p>	<p>TRENCHING, BEDDING AND BACKFILL DETAIL FOR NON-PERVIOUS (paved) AREAS</p>	<p>2.01</p>
---------------------------------------	---------------------------------------	--	--	-------------

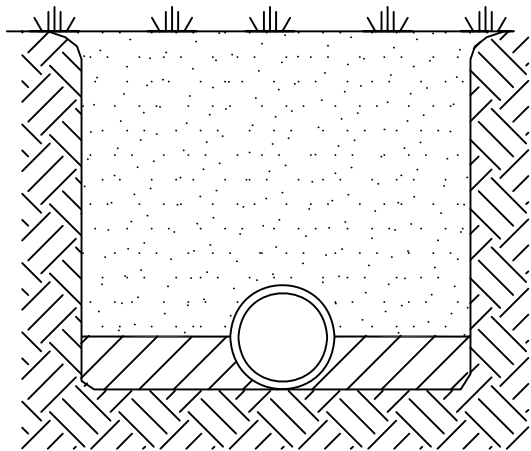

Suitable backfill compacted in 12-inch lifts to a minimum 95% of the maximum modified proctor density

— Compaction by hand in layers of 6 inches, lightly consolidated to centerline

NOTES:

1. Type 2 trench is defined as a flat-bottom trench. Lightly consolidate backfill to centerline of pipe.
2. This standard shall be utilized in the absence of specific standards. The standard of the agency controlling the Right-of-Way shall govern unless otherwise directed by the Engineer.
3. Suitable backfill shall be defined as material free from cinders, ashes, refuse, clay, organic matter, boulders, rocks or stones, or other material that in the opinion of the Engineer is unsuitable.
4. Non-paved area is a pervious area. If any part of the trench is within a concrete or asphalt curb, sidewalk, driveway, or roadway, then Standard Detail 2.01 applies.

<p>TAMPA WATER DEPARTMENT</p>	<p>APPROVED <u>Sept. 2011</u> _____</p>	<p>REVISED _____ _____ _____</p>	<p>TRENCHING, BEDDING AND BACKFILL DETAIL FOR PERVIOUS (non-paved) AREAS</p>	<p>2.02</p>
---------------------------------------	---	--	--	-------------

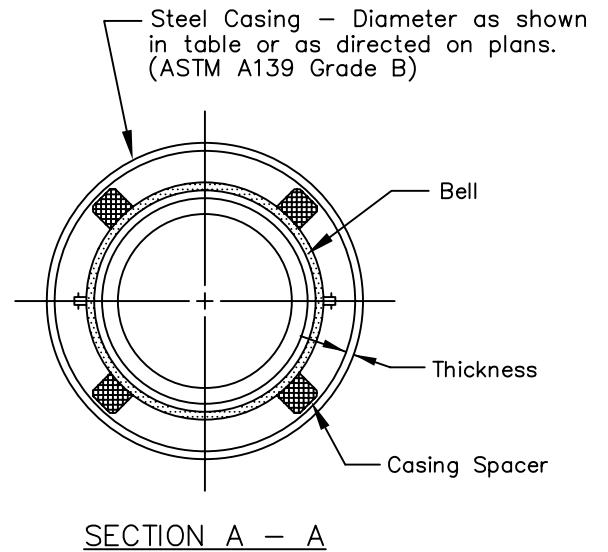
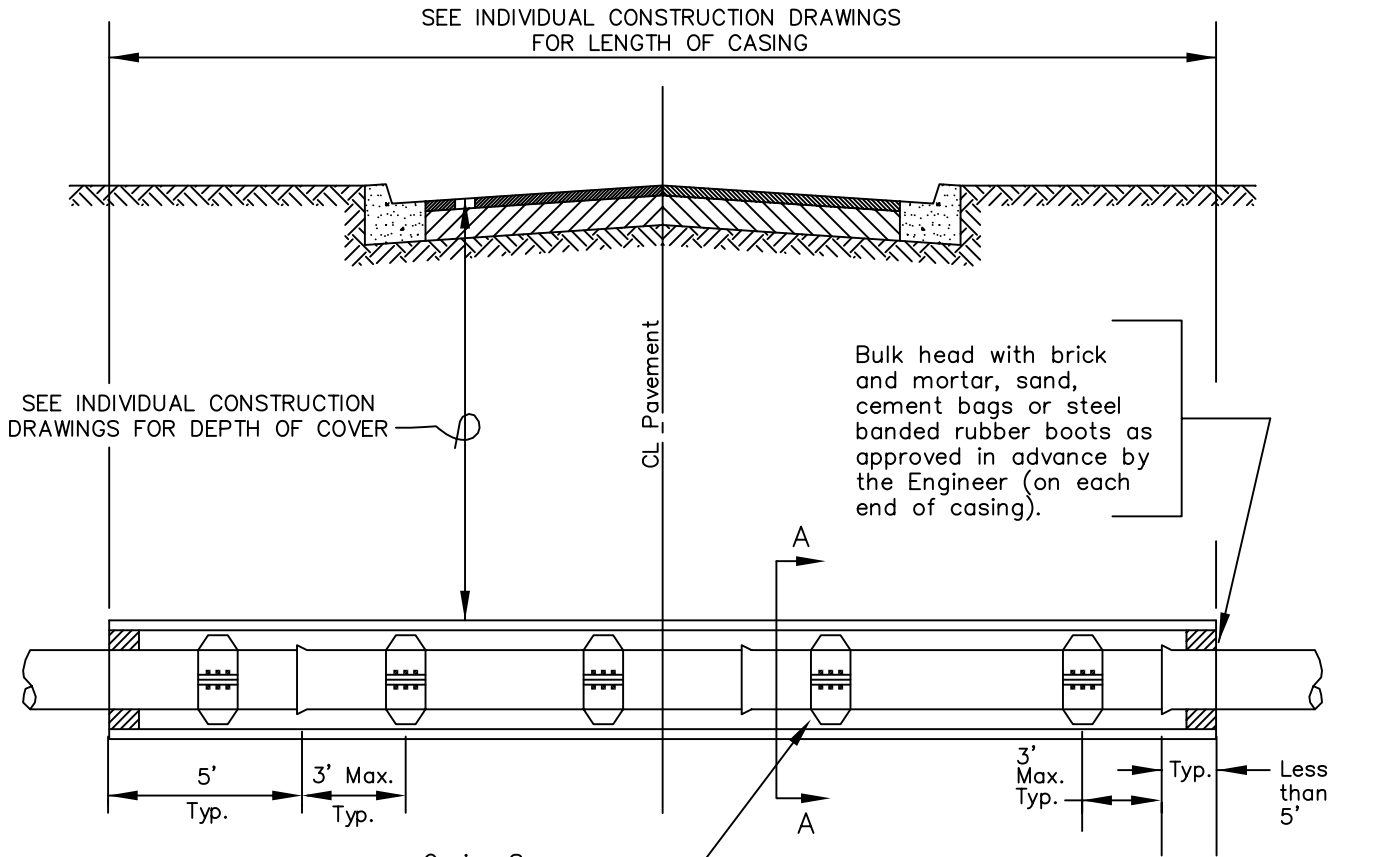

D.I.P. Carrier Pipe (P.O.) Nominal Diameter (inches)	Casing O.D. (inches)	Thickness
2	4	1/4"(.250)
4	12	1/4"(.250)
6	14	9/32"(.281)
8	16	9/32"(.281)
12	20	11/32"(.344)
16	24	13/32"(.406)
20	30	15/32"(.469)
24	36	17/32"(.531)
30	42	9/16"(.563)
36	48	9/16"(.563)
42	54	9/16"(.563)

- NOTES: 1. Pipelines with bends less than 20' from casing entrance shall be secured by both retainer glands and thrust blocks.
2. Casing pipe sizes listed are for push-on joint carrier pipe only.
3. Two spacers per joint minimum spaced as shown or as directed by the Engineer.

TAMPA WATER DEPARTMENT	APPROVED	REVISED	JACKING & BORING FOR PAVEMENT CROSSING	2.03
	Sept, 2011	_____		
	_____	_____		

SEE INDIVIDUAL CONSTRUCTION DRAWINGS
FOR LENGTH OF CASING

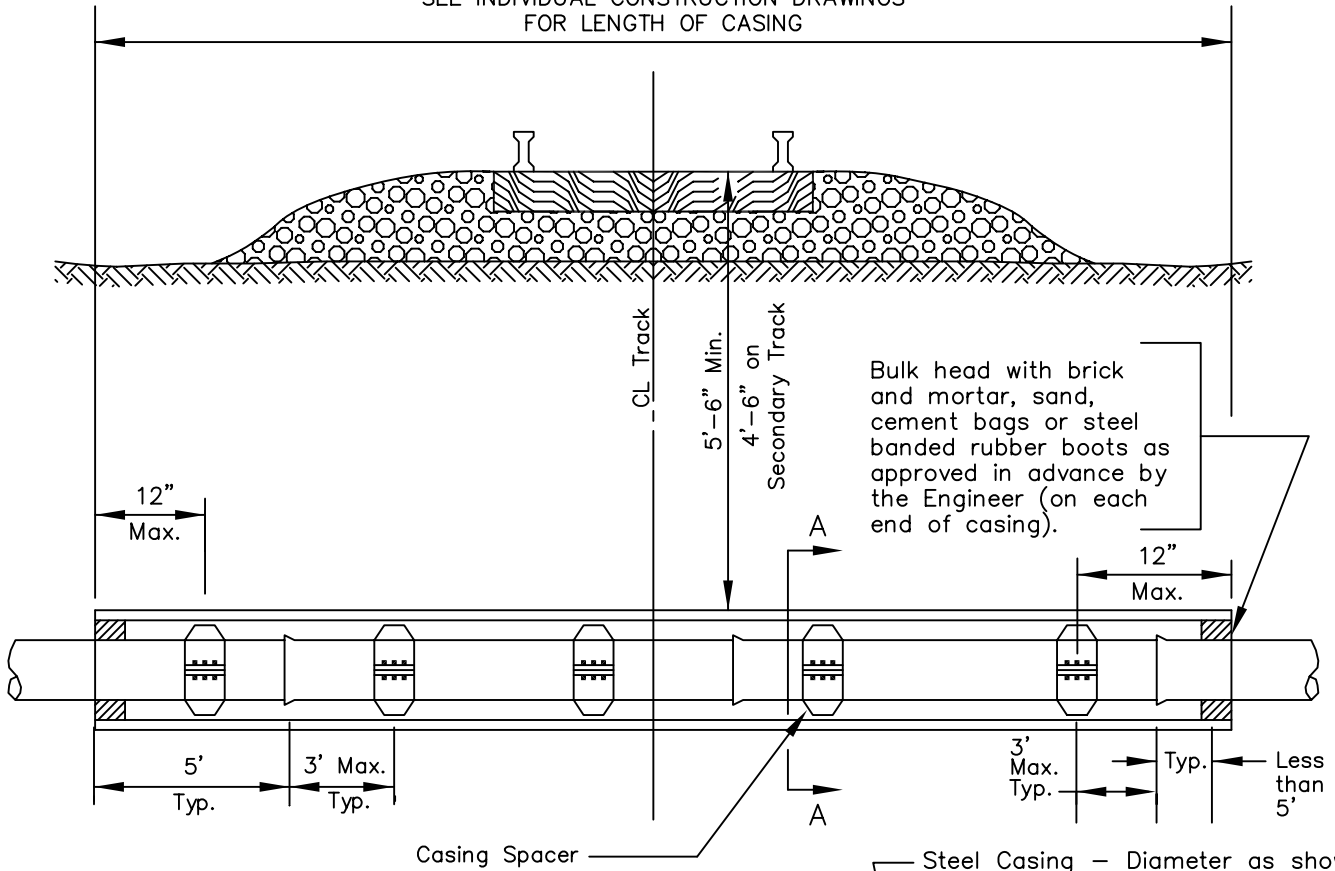

Steel Casing - Diameter as shown in table or as directed on plans. (ASTM A139 Grade B)

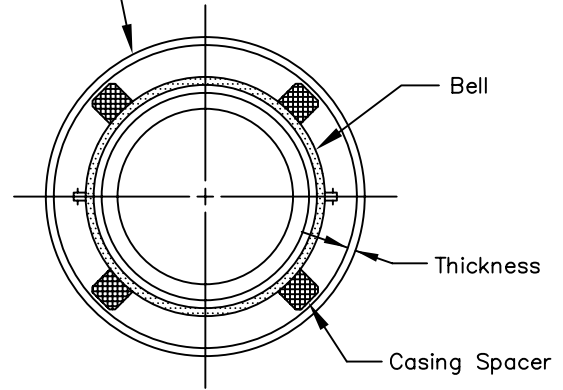

SECTION A - A

D.I.P. Carrier Pipe (P.O.) Nominal Diameter (Inches)	Casing O.D. (Inches)	Thickness
2	4	1/4"(.250)
4	12	1/4"(.250)
6	14	9/32"(.281)
8	16	9/32"(.281)
12	20	11/32"(.344)
16	24	13/32"(.406)
20	30	15/32"(.469)
24	36	17/32"(.532)
30	42	5/8"(.625)
36	48	11/16"(.688)
42	54	25/32"(.781)

- NOTES: 1. Pipelines with bends less than 20' from casing entrance shall be secured by both retainer glands and thrust blocks.
2. Casing pipe sizes listed are for push-on joint carrier pipe only.
3. Two spacers per joint minimum spaced as shown or as directed by the Engineer.

TAMPA WATER DEPARTMENT	APPROVED	REVISED	JACKING & BORING FOR RAILROAD CROSSINGS	2.04
	Sept., 2011	_____		
	_____	_____		

METHOD A

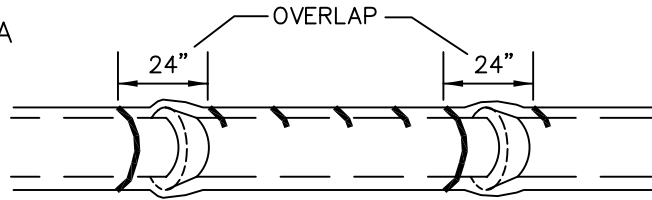

Polyethylene tube is cut into lengths approximately two feet longer than the pipe section and placed around it. After the pipe joint is assembled, the polyethylene tube is made to overlap the joint and the overlap secured in place. Since the tube is considerably larger than the barrel of pipe, it is made to fit snugly by folding over at the top and securing with tape every 24" along the pipe section.

METHOD B

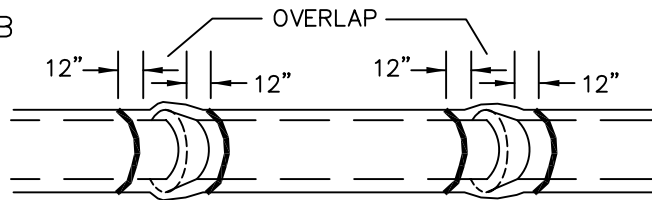

Polyethylene tube is cut one foot shorter than the length of the pipe section. After placement of the pipe, it is folded and secured snugly overall. A three foot length of polyethylene tube placed over the end of the preceeding section is then pulled in place over the joint after assembly and secured.

METHOD C

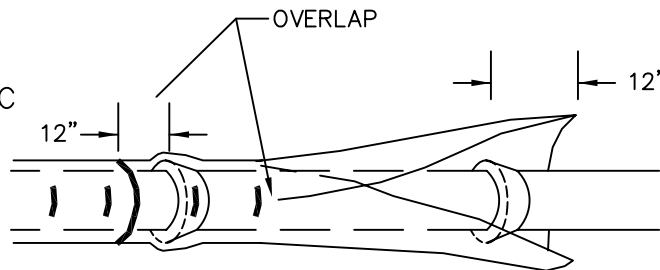

Polyethylene sheet is cut to a length two feet longer than the pipe section. The sheet is wrapped around the pipe so that it overlaps circumferentially over the top quadrant of the pipe, then secured. After joint assembly, the surplus length of polyethylene film is secured around the joint, providing an overlap of each joint. Tape at each joint and at 3' intervals in between.

- NOTES: 1. Use blue polyethylene film and tape only.
 2. Polyethylene film shall be a minimum of 8 mil. thickness.
 3. Spiral Wrap not required with polywrap.

TAMPA
WATER
DEPARTMENT

APPROVED
Sept. 2011

REVISED
JRD 4/09
JRD 9/2011

POLYETHYLENE
ENCASEMENT
INSTALLATION DETAIL

2.05

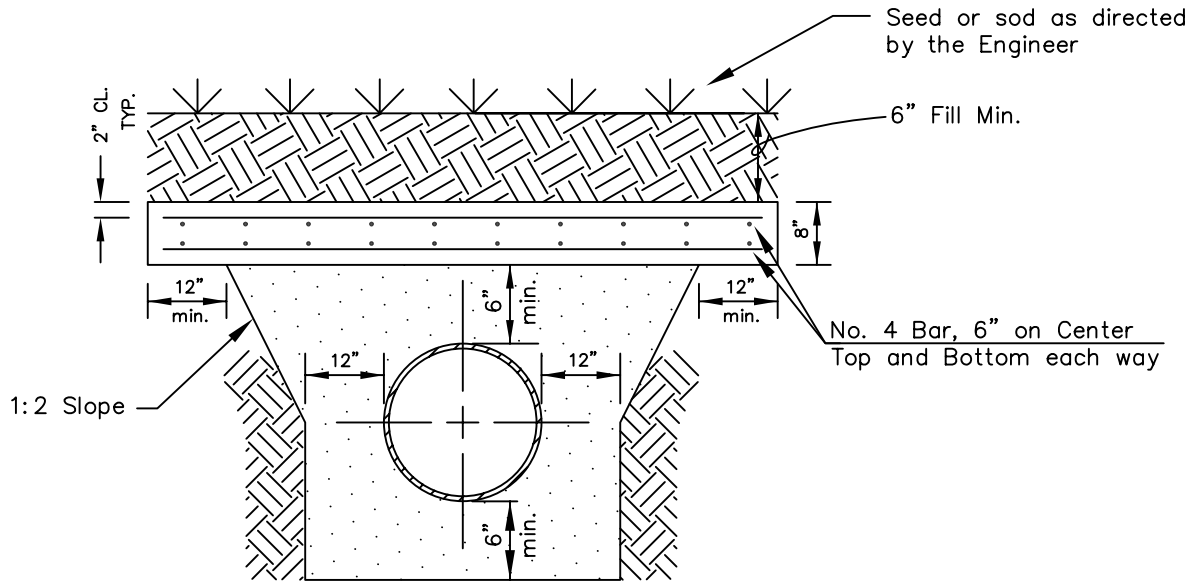

GRASSED SECTION

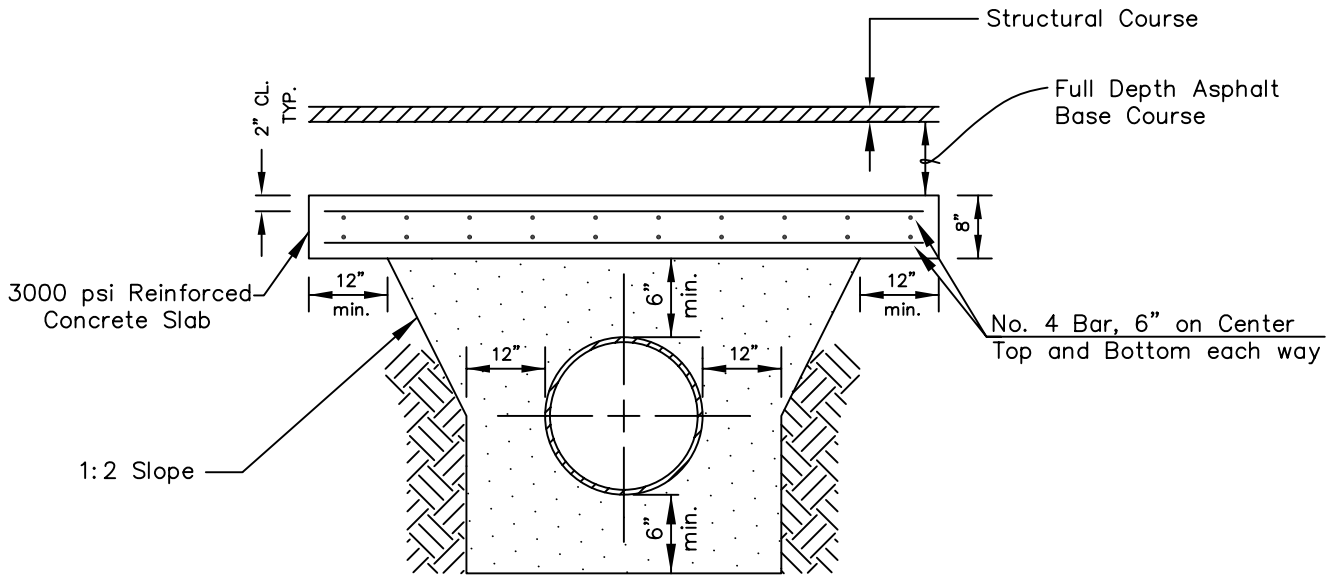

ROADWAY SECTION

NOTES:

1. Structural course and base course requirement shall be established by the agency having jurisdiction.
2. Shock pads for mains too shallow for the above configuration shall be designed on a case-by-case basis.

<p>TAMPA WATER DEPARTMENT</p>	<p>APPROVED <u>Sept. 2011</u></p>	<p>REVISED _____ _____ _____</p>	<p>REINFORCED CONCRETE SHOCK PAD (FOR COVER LESS THAN 2.5')</p>	<p>2.06</p>
---------------------------------------	---------------------------------------	--	---	-------------

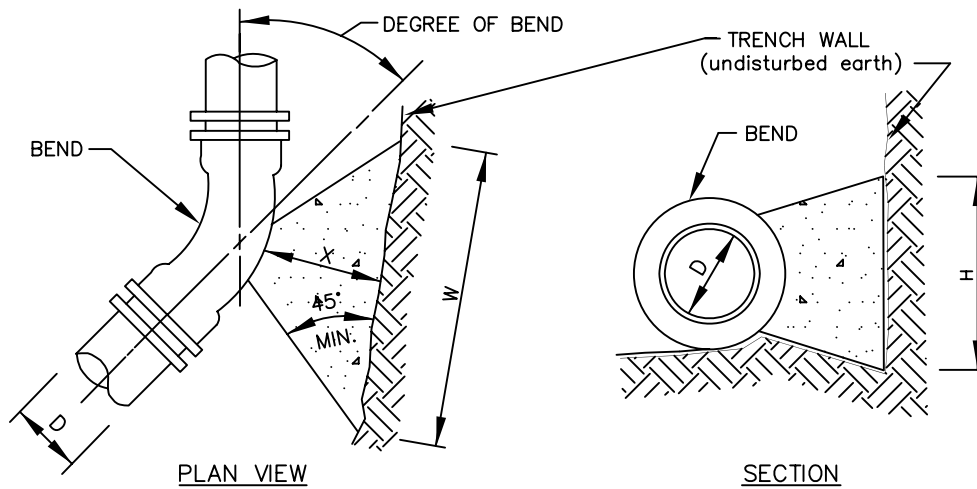

DIMENSIONS OF THRUST BLOCKS
FOR GOOD SOIL

	SIZE (D)	4"	6"	8"	12"	16"	20"	24"
11-1/4° BEND	THRUST (lbs.)	674	1393	2396	5097	8857	13,649	19,472
	BEARING AREA (ft. ²)	0.51	1.05	1.80	3.83	6.65	10.25	14.63
	CONCRETE (yds. ³)	0.005	0.015	0.033	0.104	0.239	0.459	0.783
	H (ft.)	0.6	0.8	1.1	1.6	2.1	2.6	3.1
	W (ft.)	0.9	1.3	1.6	2.4	3.2	3.9	4.7
	X (ft.)	0.4 Min.	0.6 Min.	0.8 Min.	1.2 Min.	1.6 Min.	2.0 Min.	2.3 Min.
22-1/2° BEND	THRUST (lbs.)	1342	2772	4769	10,145	17,628	27,166	38,757
	BEARING AREA (ft. ²)	1.01	2.08	3.58	7.61	13.22	20.37	29.07
	CONCRETE (yds. ³)	0.012	0.035	0.080	0.252	0.580	1.113	1.792
	H (ft.)	0.8	1.2	1.5	2.3	3.0	3.7	4.4
	W (ft.)	1.2	1.8	2.3	3.4	4.5	5.5	6.6
	X (ft.)	.06 Min.	0.9 Min.	1.2 Min.	1.7 Min.	2.2 Min.	2.8 Min.	3.0 Min.
45° BEND	THRUST (lbs.)	2632	5437	9355	19,901	34,579	53,288	76,024
	BEARING AREA (ft. ²)	1.97	4.08	7.02	14.93	25.94	39.98	57.04
	CONCRETE (yds. ³)	0.029	0.087	0.198	0.620	1.387	2.301	3.517
	H (ft.)	1.2	1.7	2.2	3.2	4.2	5.2	6.2
	W (ft.)	1.7	2.5	3.2	4.7	6.2	7.7	9.3
	X (ft.)	0.9 Min.	1.2 Min.	1.6 Min.	2.4 Min.	3.0 Min.	3.0 Min.	3.0 Min.
90° BEND	THRUST (lbs.)	4863	10,047	17,286	36,772	63,894	98,463	140,474
	BEARING AREA (ft. ²)	3.65	7.53	12.96	27.58	47.91	73.84	105.34
	CONCRETE (yds. ³)	0.068	0.203	0.459	1.360	2.561	4.250	6.496
	H (ft.)	1.6	2.2	3.0	4.3	5.7	7.0	8.4
	W (ft.)	2.3	3.4	4.4	6.4	8.5	10.5	12.6
	X (ft.)	1.2 Min.	1.7 Min.	2.2 Min.	3.0 Min.	3.0 Min.	3.0 Min.	3.0 Min.

- NOTES: 1. Concrete shall be kept at sufficient distance from joint for removal of all joint accessories including bolts.
 2. All bearing surfaces to be carried to undisturbed soil.
 3. This table shows the minimum size thrust blocks for soil bearing pressure of 2000 psf and an internal pressure of 190 psi. Cover to T.O.P. is 3 feet for 12" and smaller mains; 4 feet for 16" and larger mains.
 * 4. Poor and wet soil (silty soils, clay, muck and peat) will require larger thrust blocks.
 5. Fittings shall be completely polywrapped prior to pouring thrust blocks. *WARNING

TAMPA WATER DEPARTMENT	APPROVED Sept. 2011	REVISED _____ _____ _____	THRUST BLOCKS FOR BENDS	2.07
------------------------------	------------------------	------------------------------------	----------------------------	------

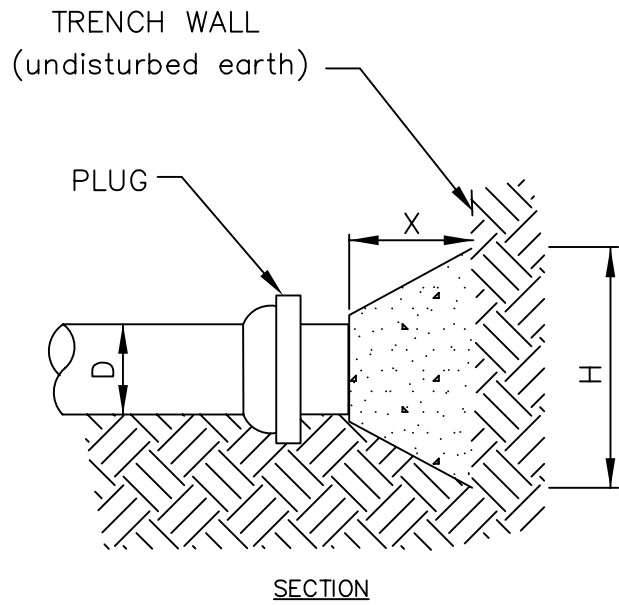
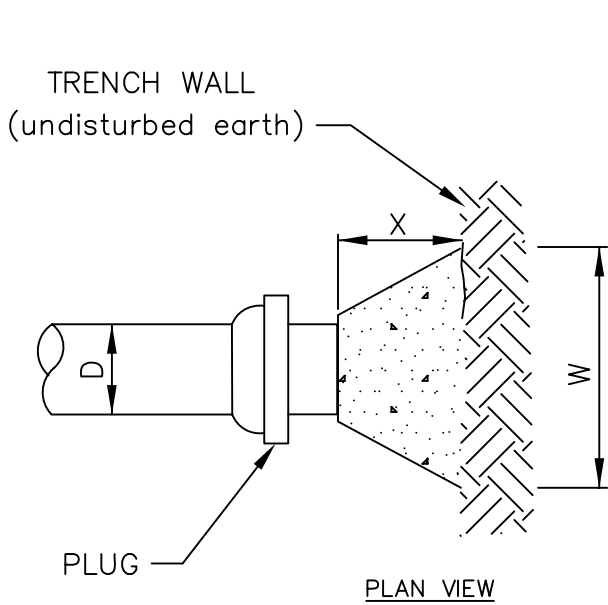

DIMENSIONS OF THRUST BLOCKS
FOR GOOD SOIL

	SIZE (D)	4"	6"	8"	12"	16"	20"	24"
PLUG	THRUST (lbs.)	3439	7104	12,223	26,002	45,180	69,624	99,330
	BEARING AREA (ft. ²)	2.58	5.33	9.17	19.50	33.89	52.22	74.50
	CONCRETE (yds. ³)	0.042	0.126	0.285	0.891	1.811	3.005	4.594
	H (ft.)	1.3	1.9	2.5	3.6	4.8	5.9	7.0
	W (ft.)	2.0	2.8	3.7	5.4	7.1	8.9	10.6
	X (ft.)	1.0 Min.	1.4 Min.	1.9 Min.	2.7 Min.	3.0 Min.	3.0 Min.	3.0 Min.

- NOTES:
- Concrete shall be kept at sufficient distance from joint for removal of all joint accessories including bolts.
 - All bearing surfaces to be carried to undisturbed soil.
 - This table shows the minimum size thrust blocks for soil bearing pressure of 2000 psf and an internal pressure of 190 psi. Cover to T.O.P. is 3 feet for 12" and smaller mains; 4 feet for 16" and larger mains.
 - *4. Poor and wet soil (silty soils, clay, muck and peat) will require larger thrust blocks.
 - Plugs shall be completely polywrapped prior to pouring thrust blocks.

*WARNING

TAMPA WATER DEPARTMENT	APPROVED <u>Sept. 2011</u>	REVISED _____ _____ _____	THRUST BLOCKS FOR PLUGS	2.08
------------------------------	-------------------------------	------------------------------------	----------------------------	------

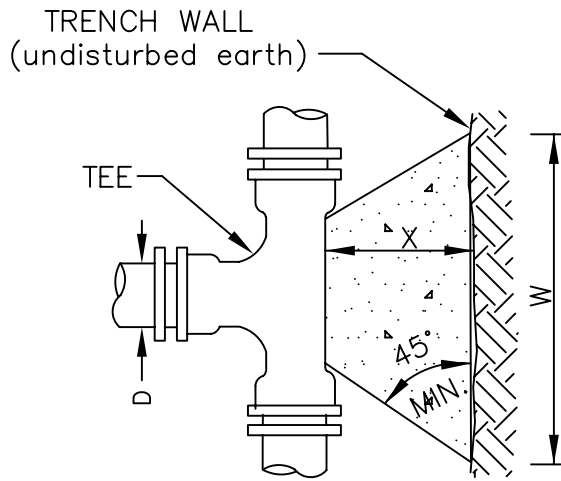

PLAN VIEW

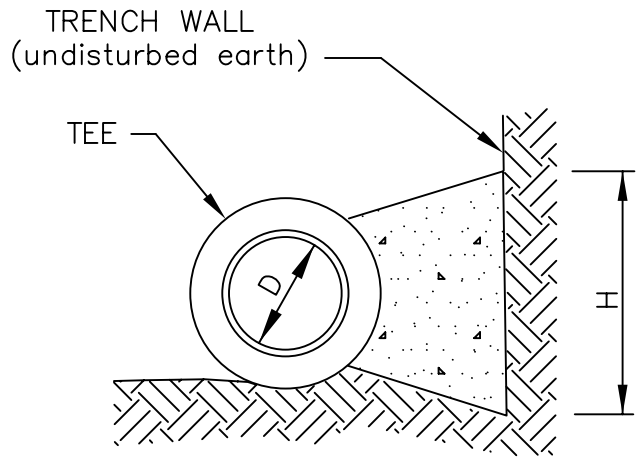

SECTION

DIMENSIONS OF THRUST BLOCKS
FOR GOOD SOIL

	SIZE (D)	4"	6"	8"	12"	16"	20"	24"
TEES	THRUST (lbs.)	3439	7104	12,223	26,002	45,180	69,624	99,330
	BEARING AREA (ft. ²)	2.58	5.33	9.17	19.50	33.89	52.22	74.50
	CONCRETE (yds. ³)	0.042	0.126	0.285	0.891	1.811	3.005	4.594
	H (ft.)	1.3	1.9	2.5	3.6	4.8	5.9	7.0
	W (ft.)	2.0	2.8	3.7	5.4	7.1	8.9	10.6
	X (ft.)	1.0 Min.	1.4 Min.	1.9 Min.	2.7 Min.	3.0 Min.	3.0 Min.	3.0 Min.

- NOTES:
1. Size (D), shall be the branch size of tees.
 2. Concrete shall be kept at sufficient distance from joint for removal of all joint accessories including bolts.
 3. All bearing surfaces to be carried to undisturbed soil.
 4. This table shows the minimum size thrust blocks for soil bearing pressure of 2000 psf and an internal pressure of 190 psi.
 - *5. Cover to T.O.P. is 3 feet for 12" and smaller mains; 4 feet for 16" and larger mains. poor and wet soil (silty soils, clay, muck and peat) will require larger thrust blocks.
 6. Tees shall be completely polywrapped prior to pouring thrust block.

*WARNING

TAMPA WATER DEPARTMENT	APPROVED <u>Sept. 2011</u>	REVISED _____ _____ _____	THRUST BLOCKS FOR TEES	2.09
------------------------------	-------------------------------	------------------------------------	---------------------------	------

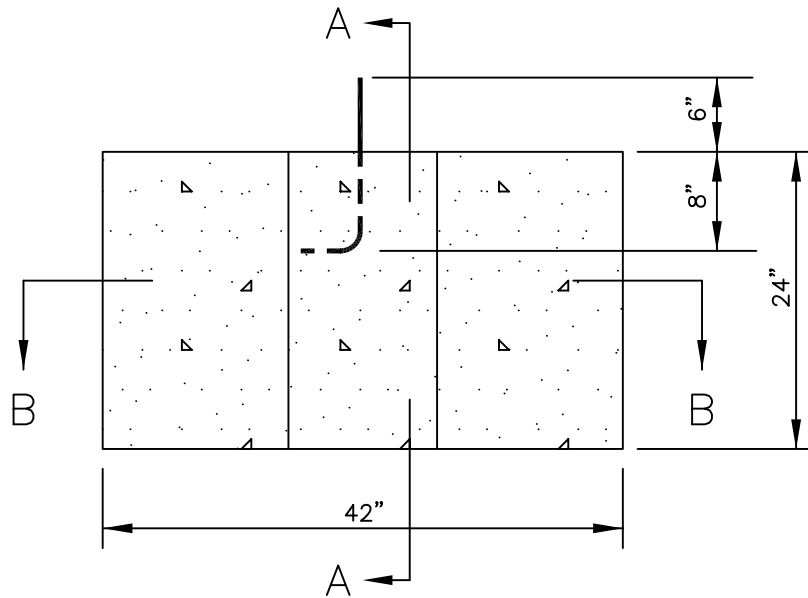

ELEVATION

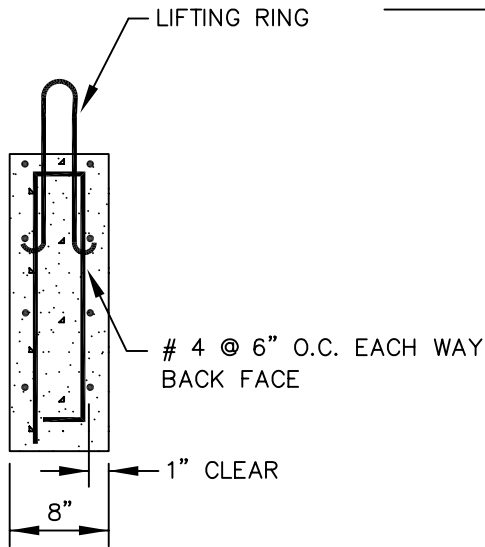

SECTION A-A

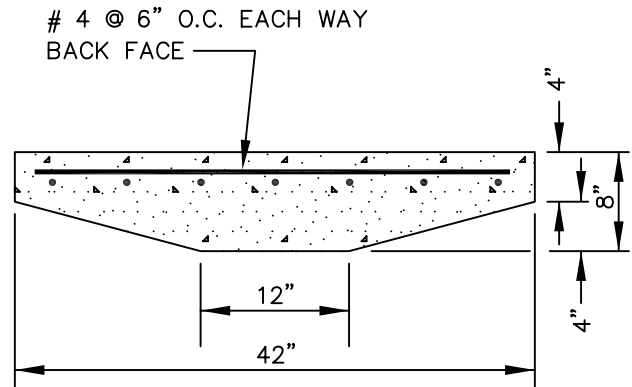

SECTION B - B

Notes:

1. Reinforcing to be standard 60 ksi deformed bar.
2. Concrete $f'c=3000$ psi
3. Precast thrust blocking to be used only on fire hydrants and 8" or smaller fittings, if allowed by the Engineer.
4. A 12"x18" spacer block shall be placed between the precast thrust block and fitting if so directed by the Engineer.

TAMPA WATER DEPARTMENT	APPROVED	REVISED	PRECAST CONCRETE THRUST BLOCK	2.10
	Sept. 2011	____		
	_____	____		

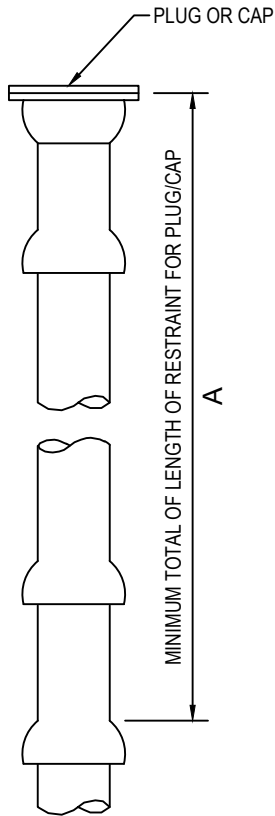
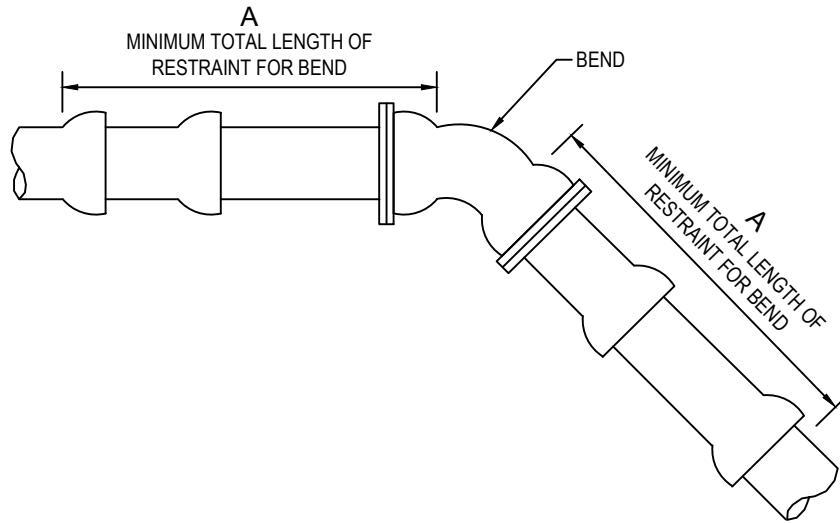

RESTRAIN "A" (LF)									
FITTING / OD	4"	6"	8"	12"	16"	20"	24"	30"	36"
11-1/4°	3	4	6	8	9	10	12	15	17
22-1/2°	6	9	12	16	17	21	25	30	35
45°/OFFSET	13	18	24	34	36	44	52	62	73
90°	31	44	58	82	87	106	125	151	176
PLUG/CAP/VALVE	55	78	102	143	143	174	204	245	285
A = MINIMUM FOOTAGE OF PIPE TO BE RESTRAINED									

NOTES:

1. THIS TABLE IS BASED ON:
 - a. MAXIMUM TEST PRESSURE OF 190 PSI
 - b. LAYING CONDITION TYPE 2 (SEE DETAILS 2.01 AND 2.02)
 - c. POOR SOIL CONDITIONS
 - d. USING D.I.P.
 - e. 3 FEET OF COVER FOR 12" AND SMALLER MAINS; 4 FEET OF COVER FOR 16" AND LARGER MAINS
 - f. HORIZONTAL BENDS ONLY - ENGINEER TO SUBMIT CALCULATIONS FOR VERTICAL RESTRAINTS
2. FOR POLYWRAPPED D.I.P., INCREASE THE FOOTAGE TO RESTRAIN BY 25%.
3. FOR PVC PIPE, INCREASE THE FOOTAGE TO RESTRAIN BY 20%.
4. "RESTRAINED" PIPE SHALL BE MANUFACTURED RESTRAINED JOINT PIPE, PUSH-ON JOINT PIPE RESTRAINED W/GASKET-TYPE "GRIPPER RESTRAINTS", OR MECHANICAL JOINT PIPE RESTRAINED BY MEGALUG (OR APPROVED EQUIVALENT).
5. ANY ADDITIONAL FITTINGS WITHIN THE RESTRAINED SECTION SHALL BE RESTRAINED ACCORDINGLY.

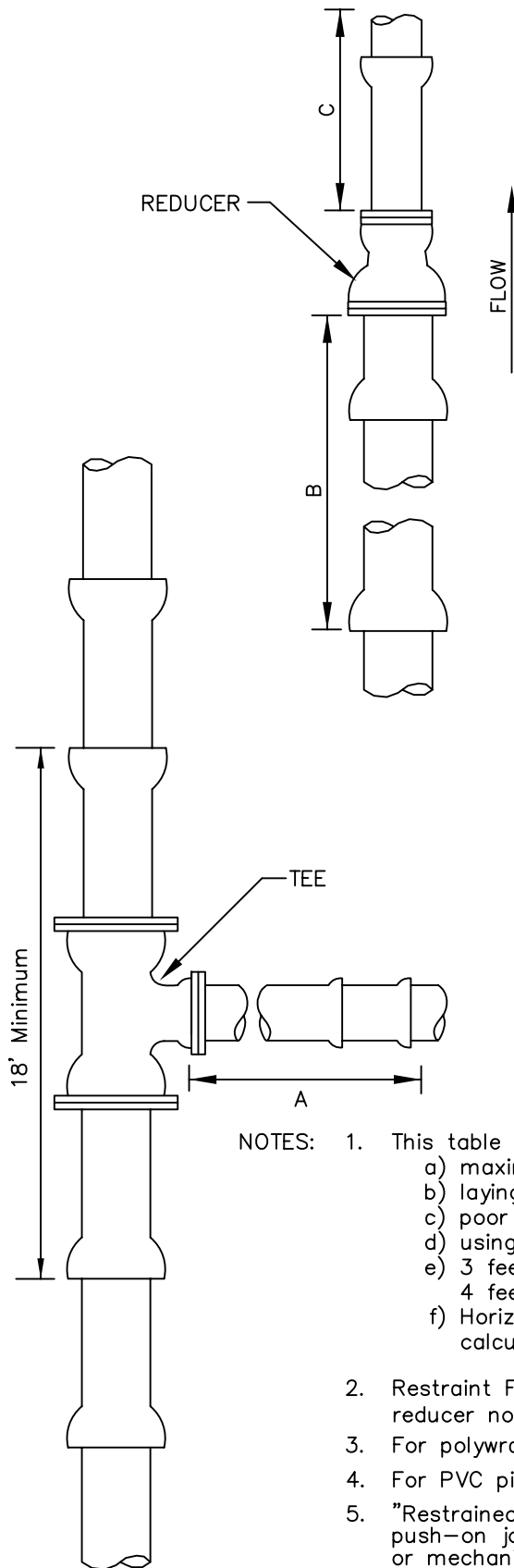

Fitting Size	Restrain (LF)		Unrestrained Straight Run (LF)
	Tee "A"	Reducer "B"	Reducer "C"
4x4	25	*	*
6x4	11	40	59
6x6	48	*	*
8x4	A.T.	73	142
8x6	38	43	56
8x8	72	*	*
12x4	A.T.	124	364
12x6	19	104	208
12x8	57	76	115
12x12	114	*	*
16x6	A.T.	121	321
16x8	27	104	212
16x12	77	61	82
16x16	118	*	*
20x6	A.T.	156	527
20x8	14	144	369
20x12	68	109	186
20x16	111	61	77
20x20	149	*	*
24x6	A.T.	189	777
24x8	A.T.	179	560
24x12	59	150	313
24x16	104	111	172
24x20	144	61	74
24x24	179	*	*
30x6	A.T.	234	1227
30x8	A.T.	226	904
30x12	45	204	542
30x16	94	173	341
30x20	135	134	208
30x24	172	86	110
30x30	220	*	*
36x6	A.T.	276	1784
36x8	A.T.	269	1328
36x12	30	251	824
36x16	83	226	551
36x20	127	195	373
36x24	165	156	245
36x30	215	86	106
36x36	261	*	*

A.T.—Restraint required at Tee only.
 *—not applicable

- NOTES:
- This table is based on:
 - maximum test pressure of 190 psi
 - laying condition type 2 (see Details 2.01 and 2.02)
 - poor soil conditions
 - using D.I.P.
 - 3 feet of cover for 12" and smaller mains;
4 feet of cover for 16" and larger mains
 - Horizontal bends only – Engineer to submit calculations for vertical restraints
 - Restraint For Reducers: If "C" straight run of pipe downstream of reducer not available, then restrain "B" upstream of reducer.
 - For polywrapped D.I.P., increase the footage to restrain by 25%.
 - For PVC pipe, increase the footage to restrain by 20%.
 - "Restrained" pipe shall be Manufactured Restrained Joint pipe, push-on joint pipe restrained w/gasket-type "Gripper Restraints", or mechanical joint pipe restrained by Megalug (or approved equivalent).
 - Any additional fittings within the restrained section shall be restrained accordingly.

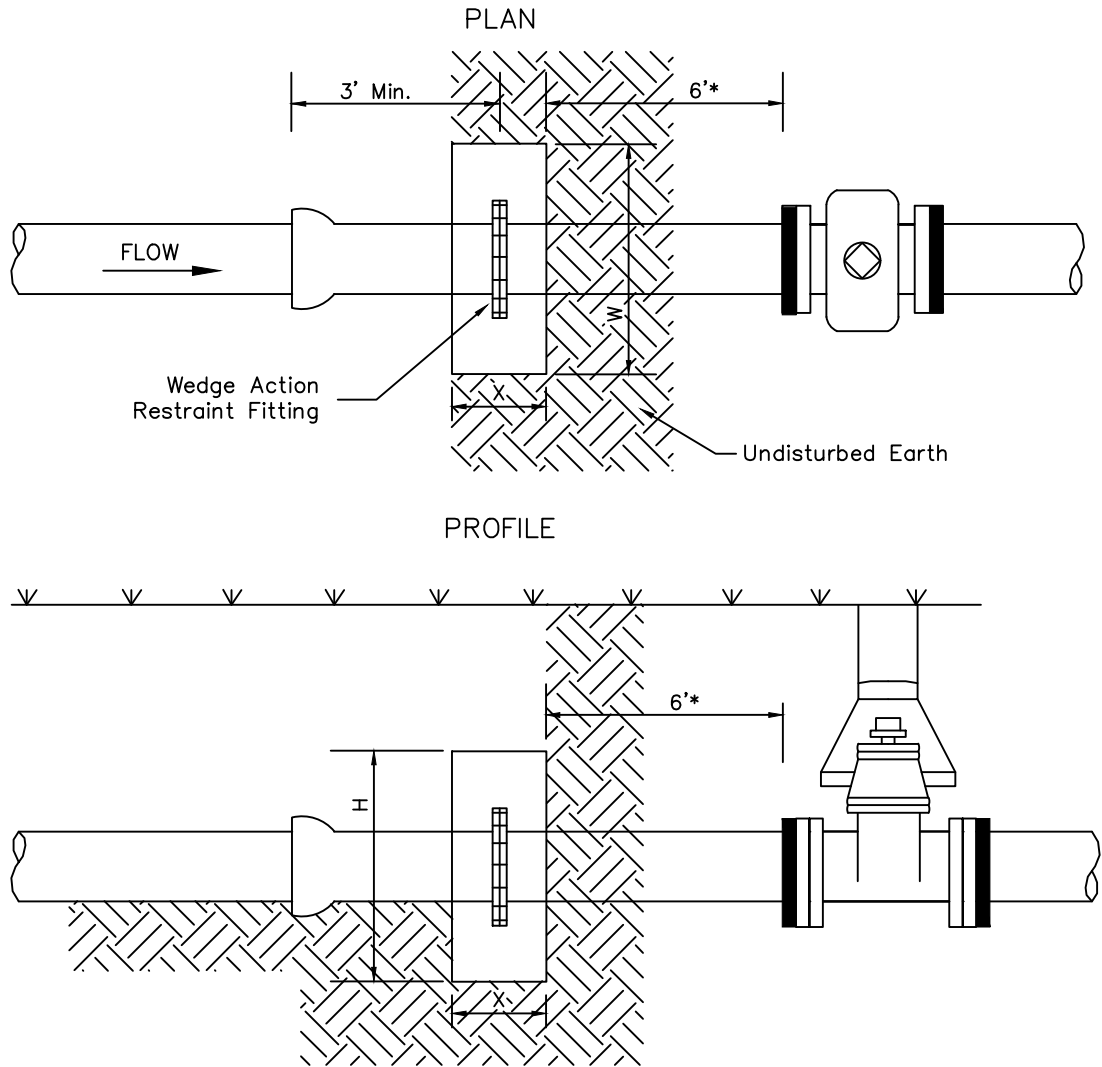

SIZE (D)	4"	6"	8"	12"	16"	20"	24"
THRUST (lbs.)	3439	7104	12,223	26,002	45,180	69,624	99,330
BEARING AREA (ft. ²)	2.58	5.33	9.17	19.50	33.89	52.22	74.50
CONCRETE (yds. ³)	0.15	0.31	0.71	1.51	3.29	5.07	7.23
H (ft.)	1.6	2.4	3.1	4.5	6.0	7.4	8.8
W (ft.)	1.6	2.4	3.1	4.5	6.0	7.4	8.8
X (ft.)	1.5 Min.	1.5 Min.	2.0 Min.	2.0 Min.	2.5 Min.	2.5 Min.	2.5 Min.

- NOTES:
- Concrete shall be kept at sufficient distance from joint for removal of all joint accessories including bolts.
 - All bearing surfaces to be carried to undisturbed soil.
 - This table shows the minimum size thrust blocks for soil bearing pressure of 2000 psf and an internal pressure of 190 psi. Cover to T.O.P. is 3 feet for 12" and smaller mains; 4 feet for 16" and larger mains.
 - Poor and wet soil (silty soils, clay, muck and peat) will require larger thrust blocks, as directed by the Engineer.
 - Fittings shall be completely polywrapped prior to pouring thrust blocks.
 - *6. Closest distance to valve for deadman to remain effective.

TAMPA WATER DEPARTMENT	APPROVED	REVISED	DEADMAN THRUST BLOCK	2.12A
	Sept. 2011	____		

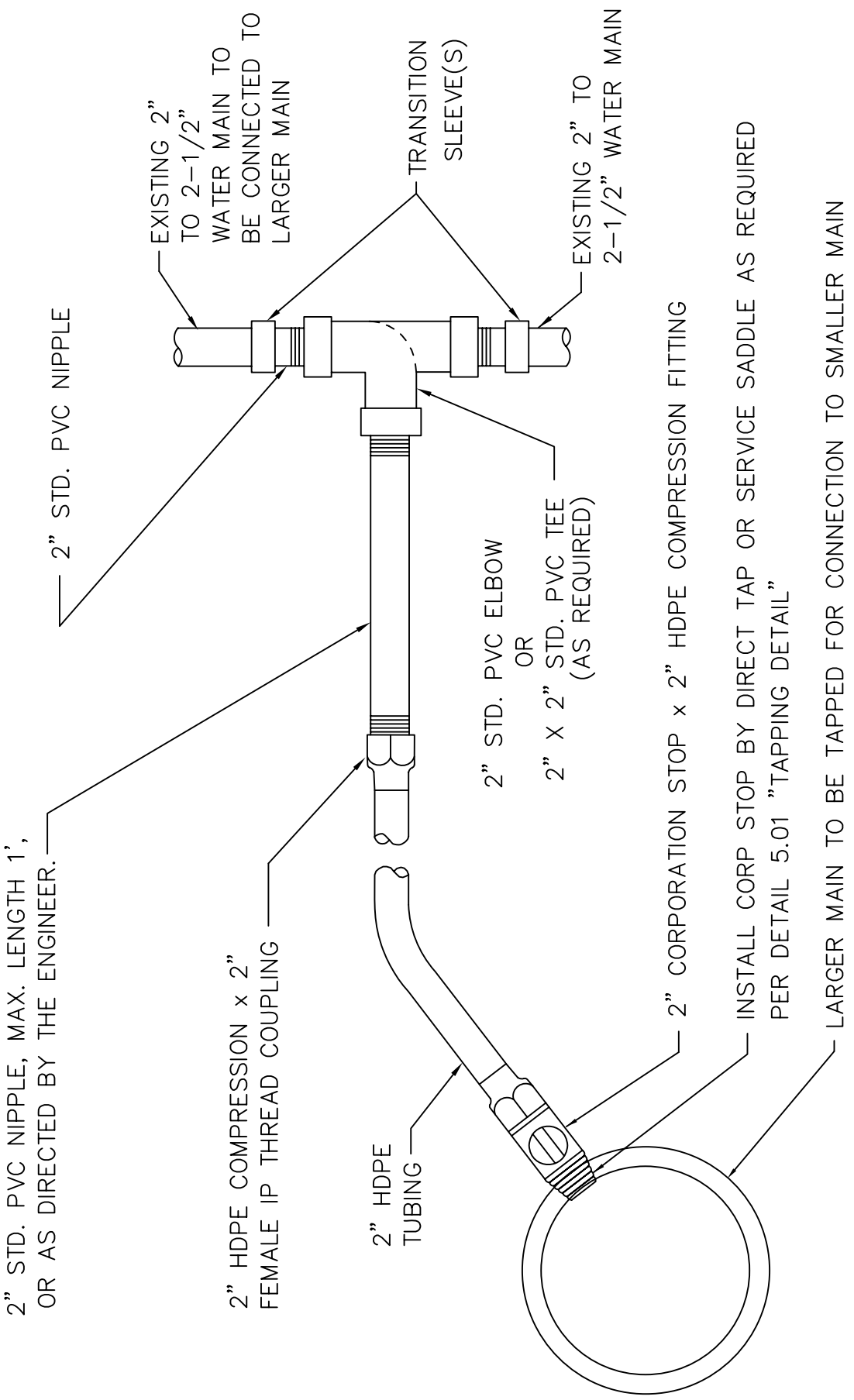

NOTE: SEE DETAIL 5.01 TO DETERMINE WHEN SADDLES ARE REQUIRED FOR CORP INSTALLATION

<p>TAMPA WATER DEPARTMENT</p>	<p>APPROVED Sept. 2011</p>	<p>REVISED</p> <p>_____ _____ _____</p>	<p>"TAPPED" CONNECTION FROM DI, CI, OR PVC PIPE TO <4" WATER MAINS</p>	<p>2.13</p>
---------------------------------------	-------------------------------------	---	---	-------------

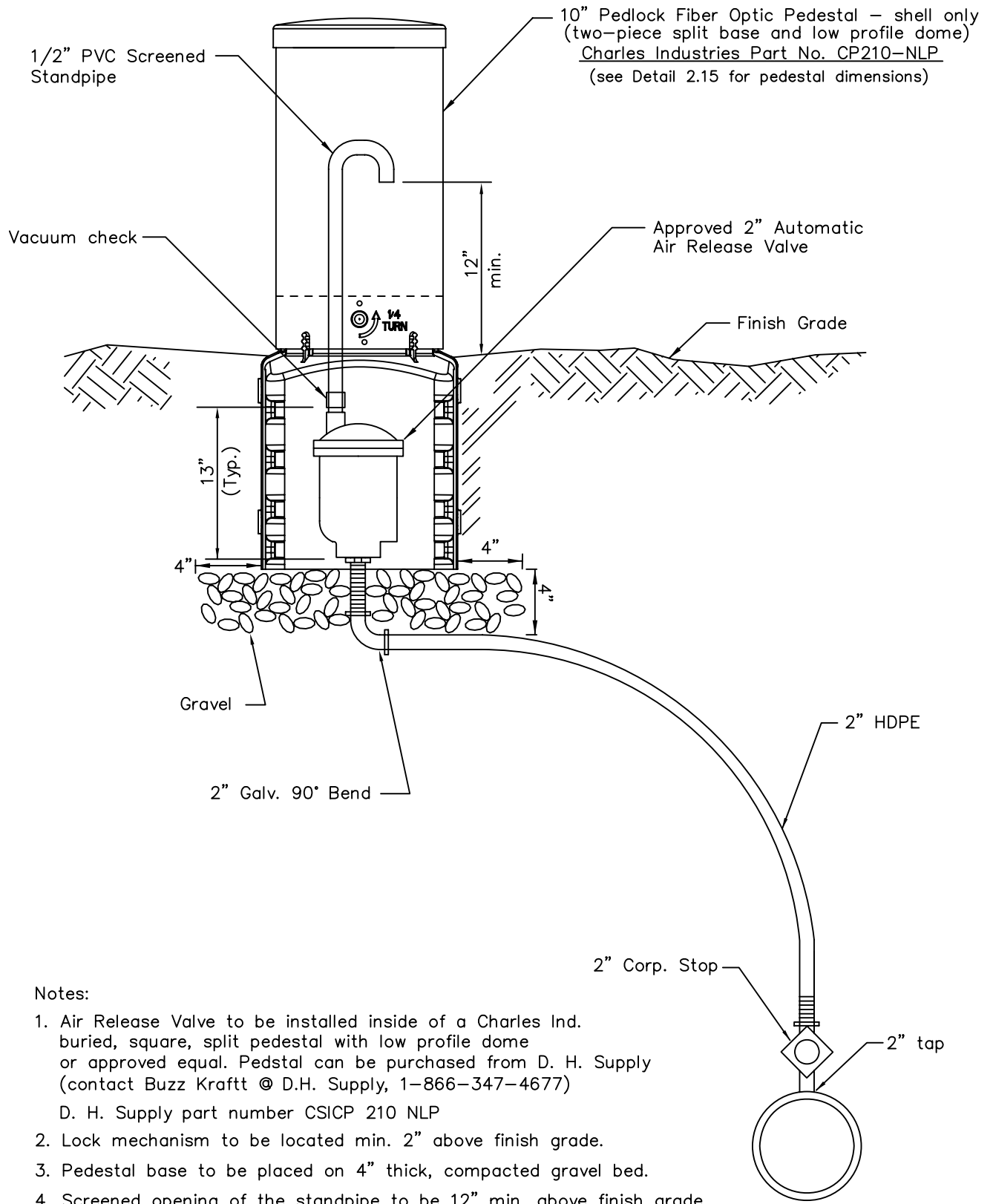

TAMPA
WATER
DEPARTMENT

APPROVED
Sept. 2011

REVISED

AUTOMATIC
AIR RELEASE VALVE

2.14

1/2" PVC Screened Standpipe

CHARLES INDUSTRIES LLPH MODEL 117
(two-piece, split base and low profile dome)
Charles Industries Part No. 117 SS07-2 0 000 BK

AS TALL AS POSSIBLE
INSIDE PEDESTAL COVER

Approved Automatic
Air Release/Air Vacuum Valve (AVAR)
Install Off-Center in Pedestal (lengthwise)
to provide easy access to Curb Stop Op Nut

Finish Grade

FORD 2" CURB STOP (FIPxFIP)
LOCATE STOP NEAR GRAVEL,
w/MINIMUM NIPPLE BETWEEN
STOP & AVAR BODY. FACE
OPERATOR NUT TO OPEN AREA
(LENGTHWISE) IN BOX,
FOR EASY ACCESS.

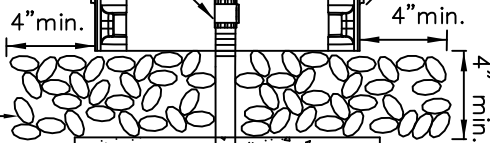

6"x2'x2'
CONCRETE PAD
W/ WIRE MESH (6 GA. 4"x4" W.W.F.)

Note: Pedestal is shown in
Detail to illustrate assembly
configuration only. Consult
Charles Industries LLPH 117
brochure for actual pedestal
dimensions.

2" SCH. 40 BRASS PIPE
OR 316 SS SCH 40

2" SCH. 40 BRASS PIPE
OR SDR 9 HDPE TUBE
OR 316 SS SCH 40

(2) STREET ELL
TYPE "K" COPPER
OR SCH 40 BRASS
OR 316 SS SCH 40

(1) 2" STREET ELL
(1) 2" ELL

2% MINIMUM SLOPE
w/ 3' Min. Cover

2" Corp. Stop

2" TAP W/
STAINLESS STEEL
DOUBLE STRAP
SERVICE SADDLE

Notes:

1. Air Release Valve to be installed inside of a Charles Ind. buried, square, split pedestal with low profile dome or approved equal.
2. Lock mechanism to be located min. 2" above finish grade.
3. Pedestal base to be placed on 4" thick, compacted gravel bed, on top of 6" thick 2'x2' concrete pad.
4. Obtain (2) Reflective WATER stickers from City and affix to pedestal.

TAMPA
WATER
DEPARTMENT

APPROVED
Jan. 2016

REVISED
RNM Rev. 3

AUTOMATIC AIR VACUUM/
AIR RELEASE VALVE

2.14C

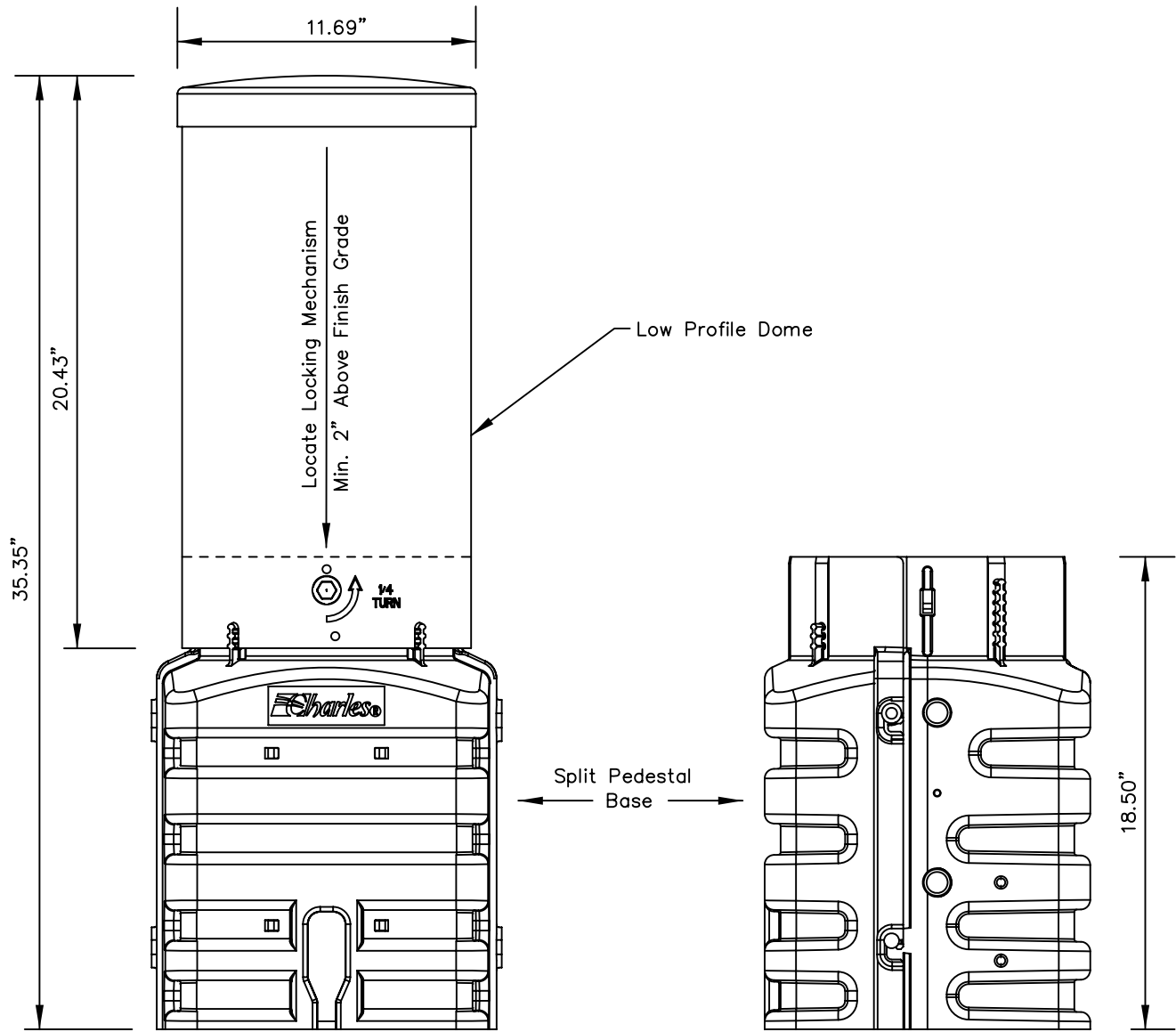

BASE, ROTATED 90°

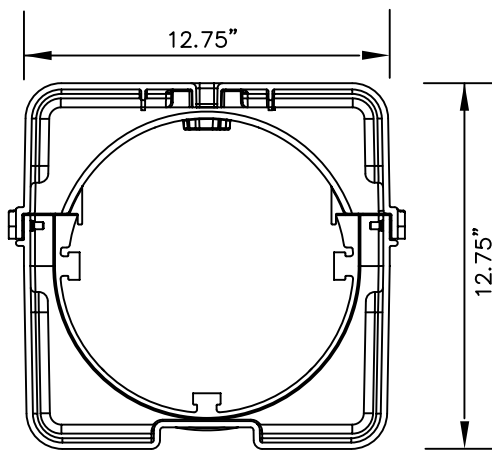

PEDESTAL ASSEMBLY

<p>TAMPA WATER DEPARTMENT</p>	<p>APPROVED Sept. 2011</p>	<p>REVISED _____ _____ _____</p>	<p>PEDESTAL FOR AUTOMATIC AIR RELEASE VALVE</p>	<p>2.15</p>
---------------------------------------	--------------------------------	--	---	-------------

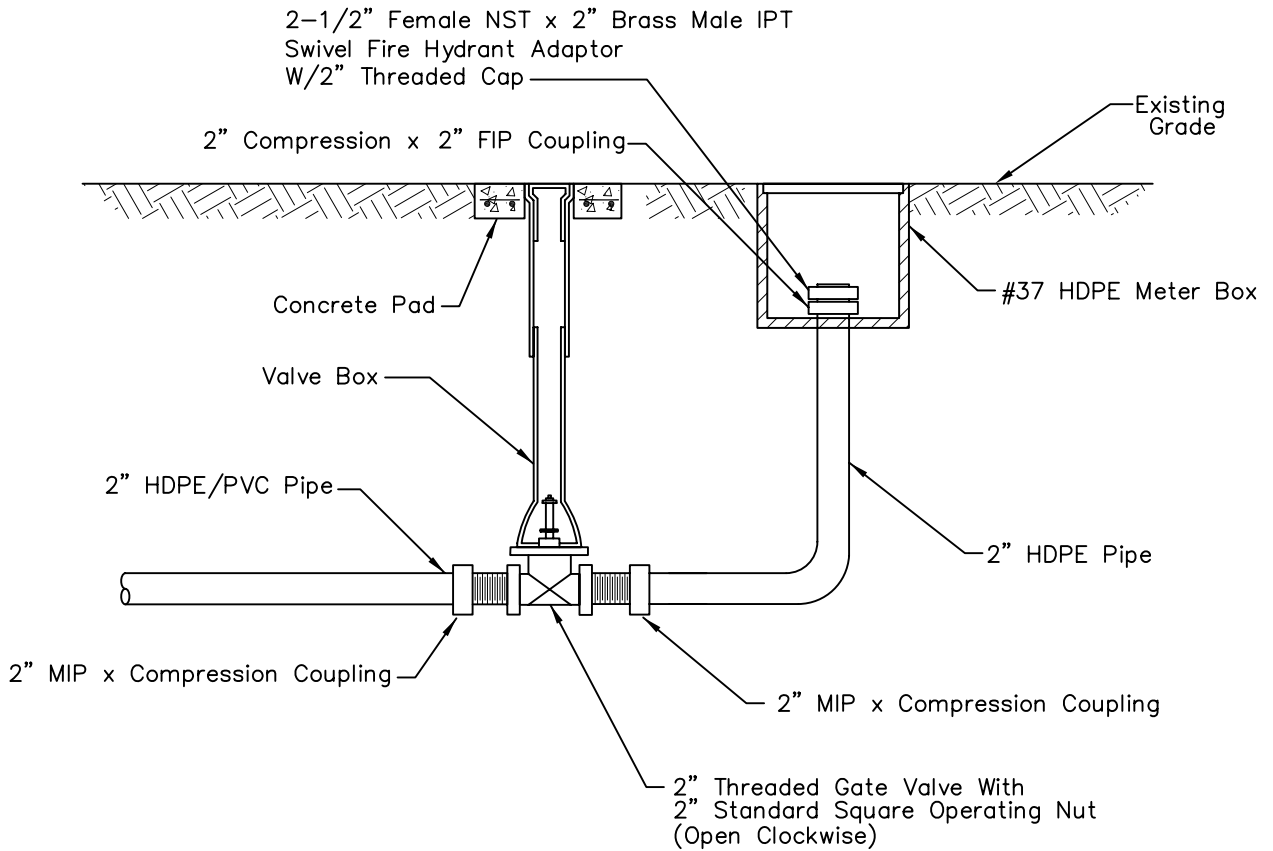

BLOW-OFF FOR 2" MAINS

No galvanized pipes or fittings allowed
 Schedule 80 PVC Allowed

N.T.S.

TAMPA WATER DEPARTMENT	APPROVED	REVISED	BLOW-OFF VALVE ASSEMBLY W/2" PVC OR HDPE PIPE	2.16
	<u>Sept. 2011</u>	_____		
	_____	_____		

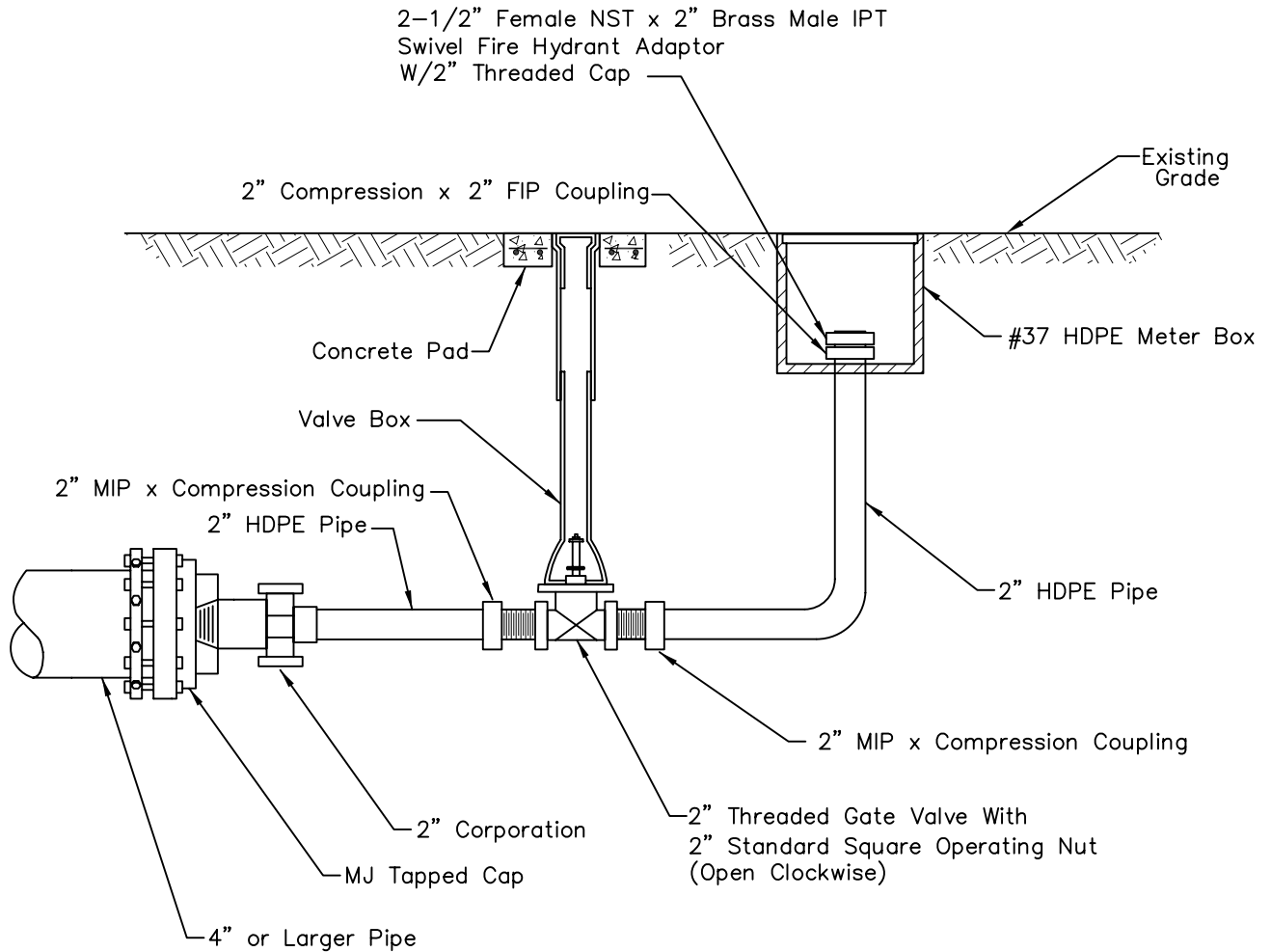

BLOW-OFF FOR ≥ 4 " MAINS

No galvanized pipes or fittings allowed
Schedule 80 PVC Allowed

N.T.S.

TAMPA WATER DEPARTMENT	APPROVED <u>Sept. 2011</u> _____	REVISED _____ _____ _____	BLOW-OFF VALVE ASSEMBLY FOR ≥ 4 " MAINS W/DI, CI OR PVC PIPE	2.17
------------------------------	--	--	---	------

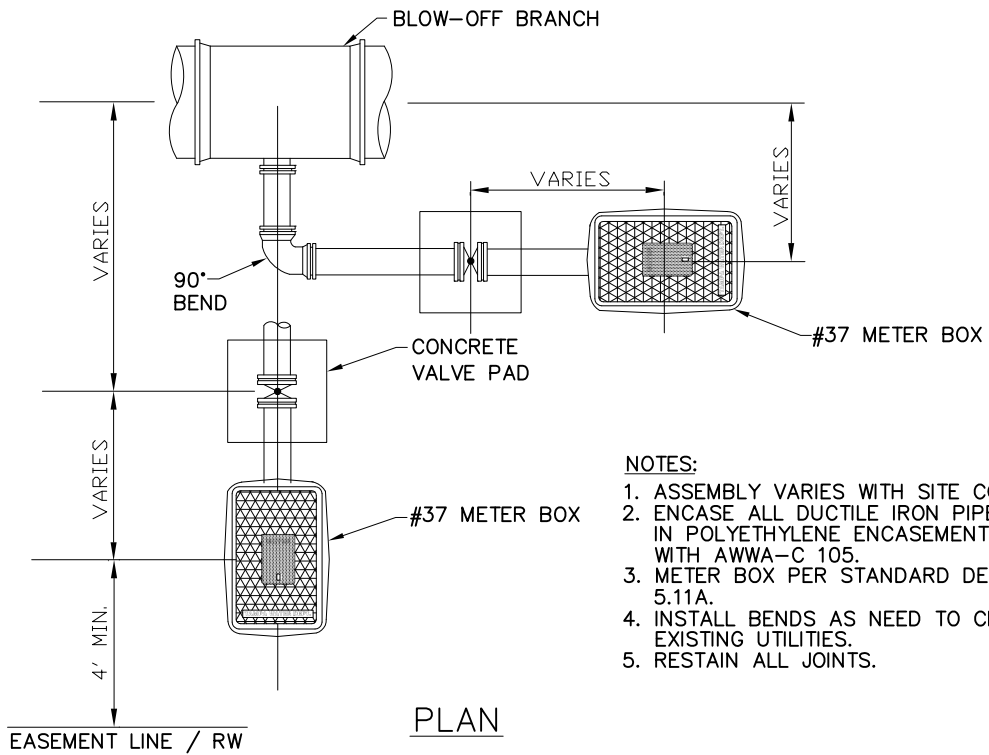

- NOTES:**
1. ASSEMBLY VARIES WITH SITE CONDITIONS
 2. ENCASE ALL DUCTILE IRON PIPE AND FITTINGS. IN POLYETHYLENE ENCASEMENT IN ACCORDANCE WITH AWWA-C 105.
 3. METER BOX PER STANDARD DETAIL 5.11 OR 5.11A.
 4. INSTALL BENDS AS NEED TO CROSS EXISTING UTILITIES.
 5. RESTRAIN ALL JOINTS.

PLAN

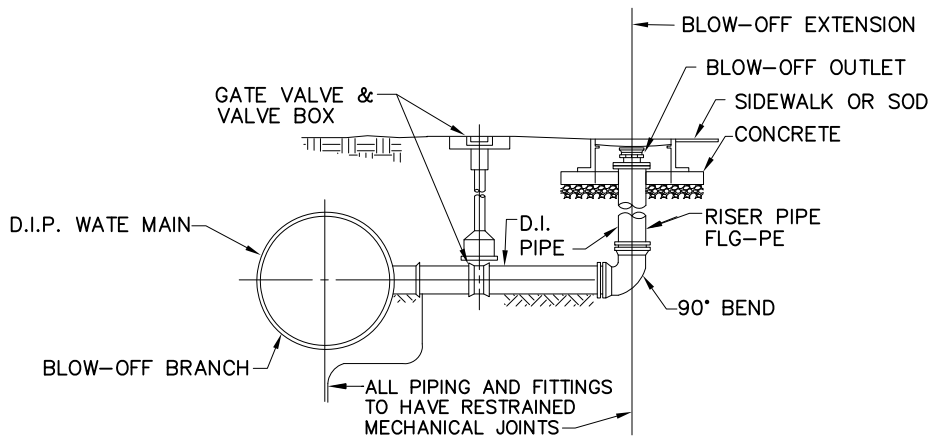

PROFILE

NOT TO SCALE

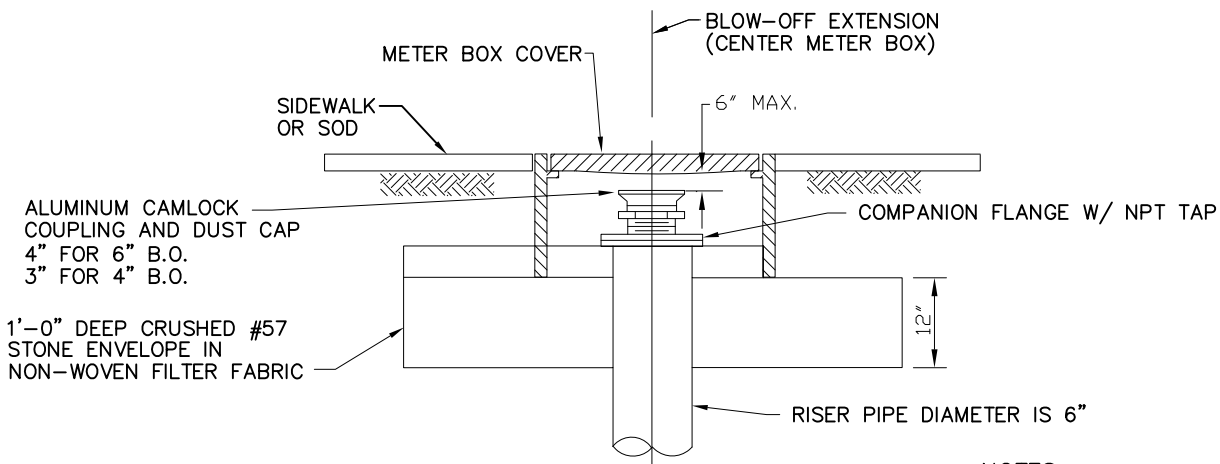

BLOW-OFF OUTLET DETAIL

NOT TO SCALE

- NOTES:**
- CONTRACTOR SHALL DRILL 1/4" HOLE IN CENTER OF CAMLOCK DUST CAP.

TAMPA
WATER
DEPARTMENT

APPROVED

June 2012

REVISED

BLOW-OFF VALVE ASSEMBLY
FOR 4" & 6" MAINS
W/DI, CI OR PVC PIPE

2.17A

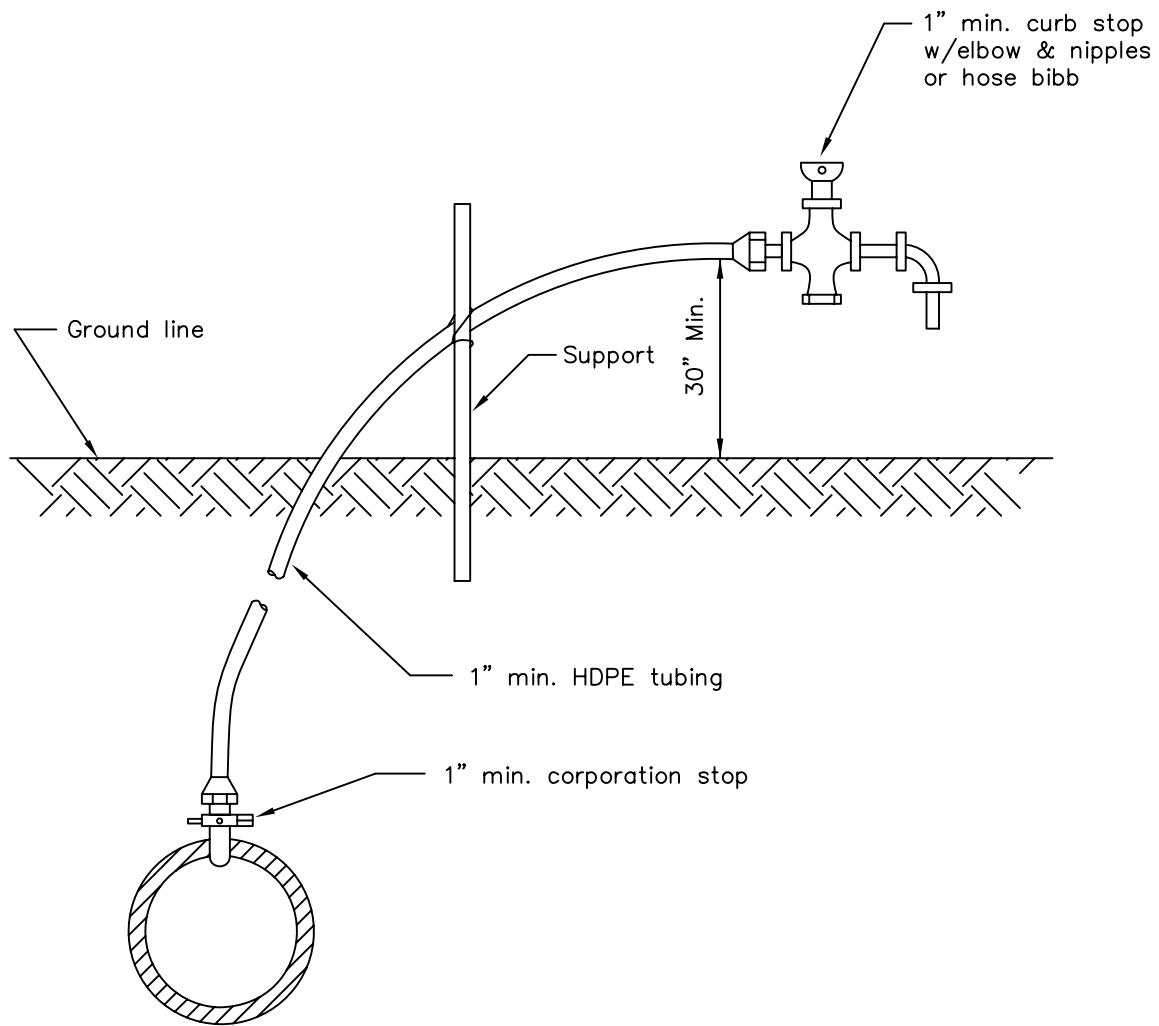

Notes:

1. Water outlet shall be held up off the ground so as not to interfere with the sampling process.
2. Corporation stop to be removed and brass plug installed in tapped main after operation.

<p>TAMPA WATER DEPARTMENT</p>	<p>APPROVED Sept. 2011</p>	<p>REVISED _____ _____ _____</p>	<p>TEMPORARY SAMPLE TAP INSTALLATION w/DI, CI, OR PVC PIPE</p>	<p>2.18</p>
---------------------------------------	--------------------------------	--	--	-------------

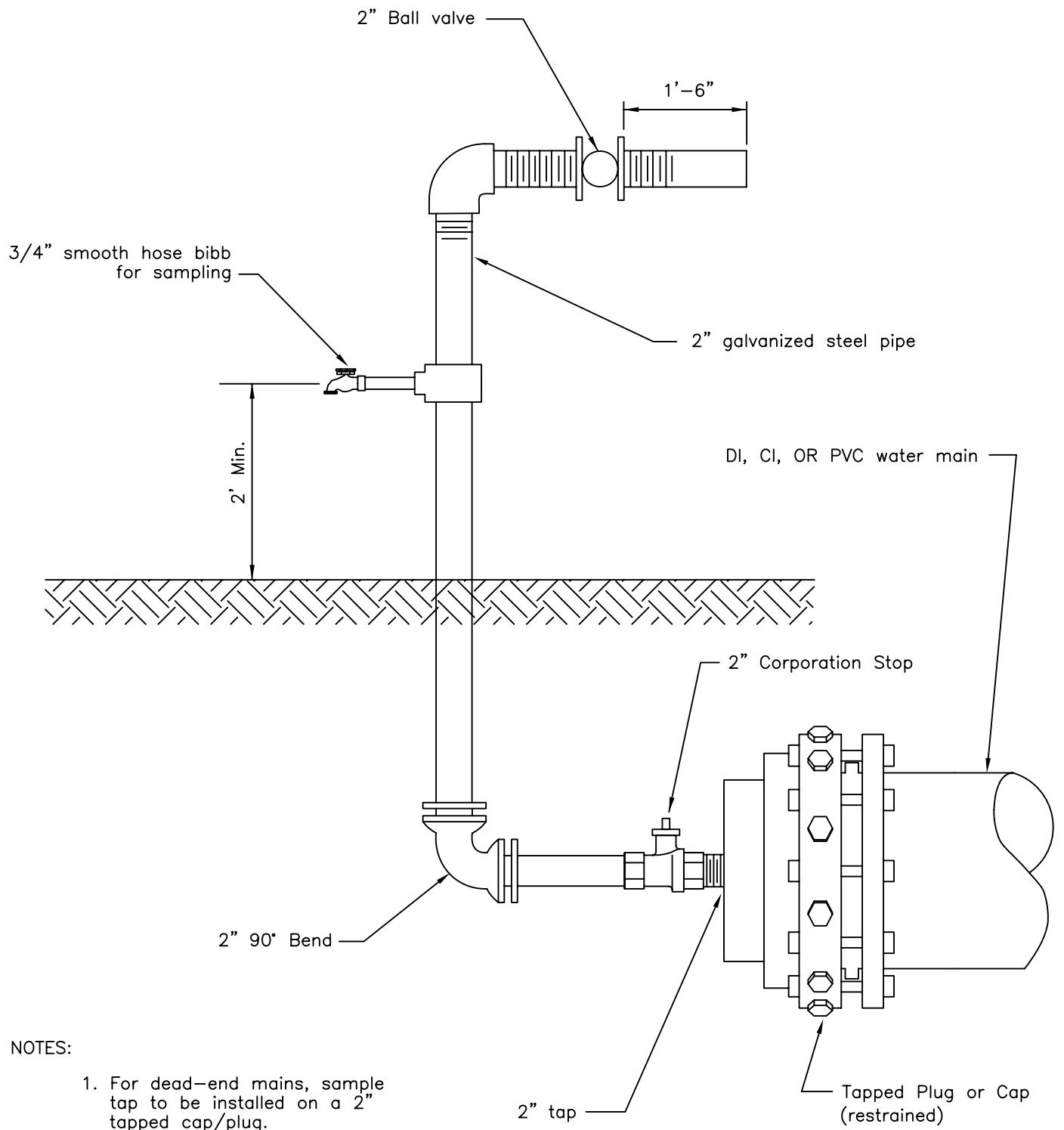

NOTES:

1. For dead-end mains, sample tap to be installed on a 2" tapped cap/plug.
2. Flushing/sampling arrangement to be removed after disinfection of main line.
3. After operation complete, install brass plug at corporation stop.

TAMPA WATER DEPARTMENT	APPROVED	REVISED	TEMPORARY SAMPLE TAP INSTALLATION FOR END OF LINE W/DI, CI, OR PVC PIPE	2.19
	Sept. 2011	_____		
	_____	_____		

WIRE MESH

(6 GAUGE 4" x 4" W.W.F.)

3000 PSI CONCRETE PAD
(See Notes Below
& DETAIL 3.06)

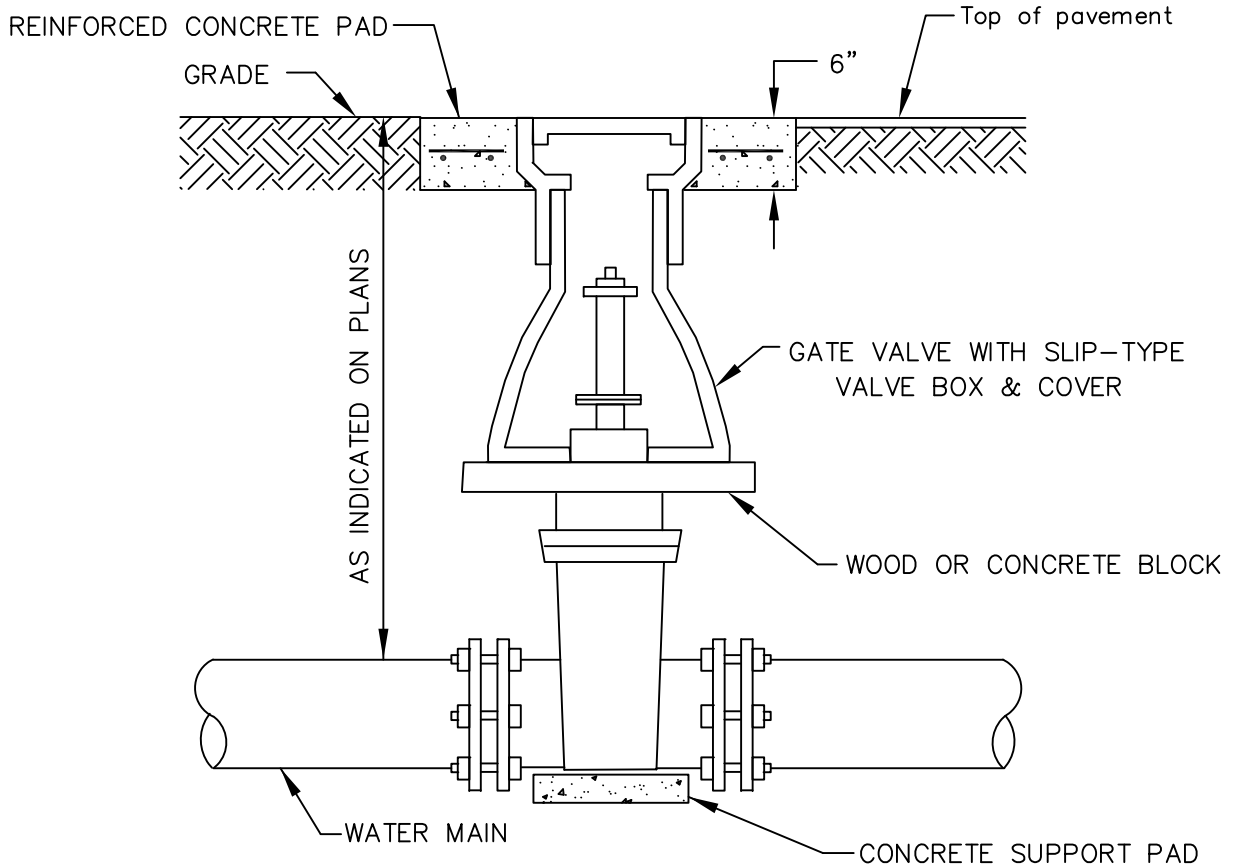
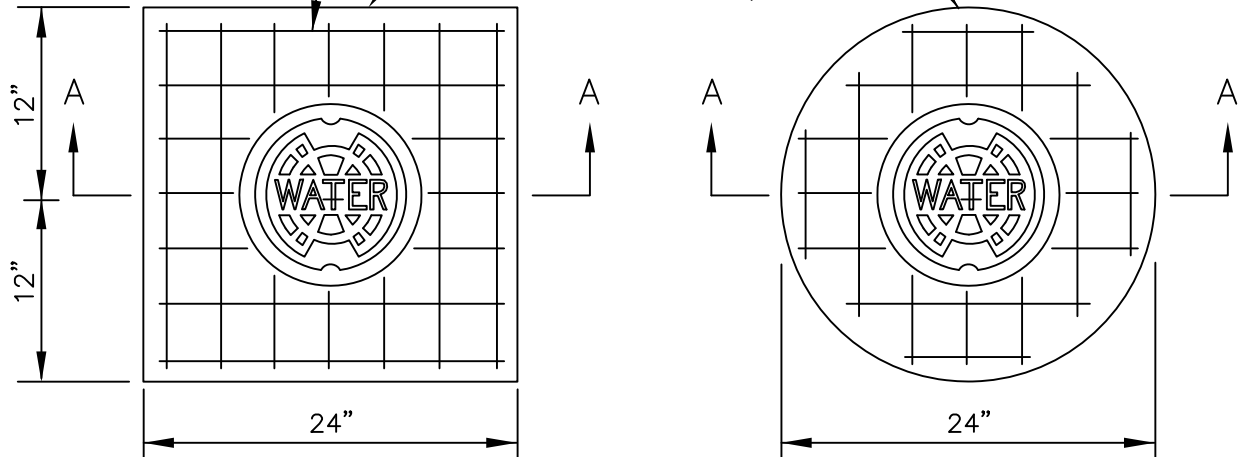

SECTION A-A

Notes :

1. Circular or square concrete pad required for all valve box installations. N.T.S.
2. Cast iron valve boxes shall be firmly supported and centered and plumb over the operating nut of the valve. Valve box cover shall be flush with the surface of the finished pavement, or grade or at such other level as may be directed by the Department.
3. "Blue" Water Valve locate markers (curb markers) required for all valve installations.
4. Embed bronze valve info disk into concrete valve box collar, per Detail 3.06.

TAMPA WATER DEPARTMENT	APPROVED	REVISED	VALVE INSTALLATION W/VALVE BOX & PAD FOR DI OR CI PIPE	3.01
	Sept. 2015	____		

WIRE MESH
(6 GAUGE 4" x 4" W.W.F.)

3000 PSI CONCRETE PAD
(See Notes)

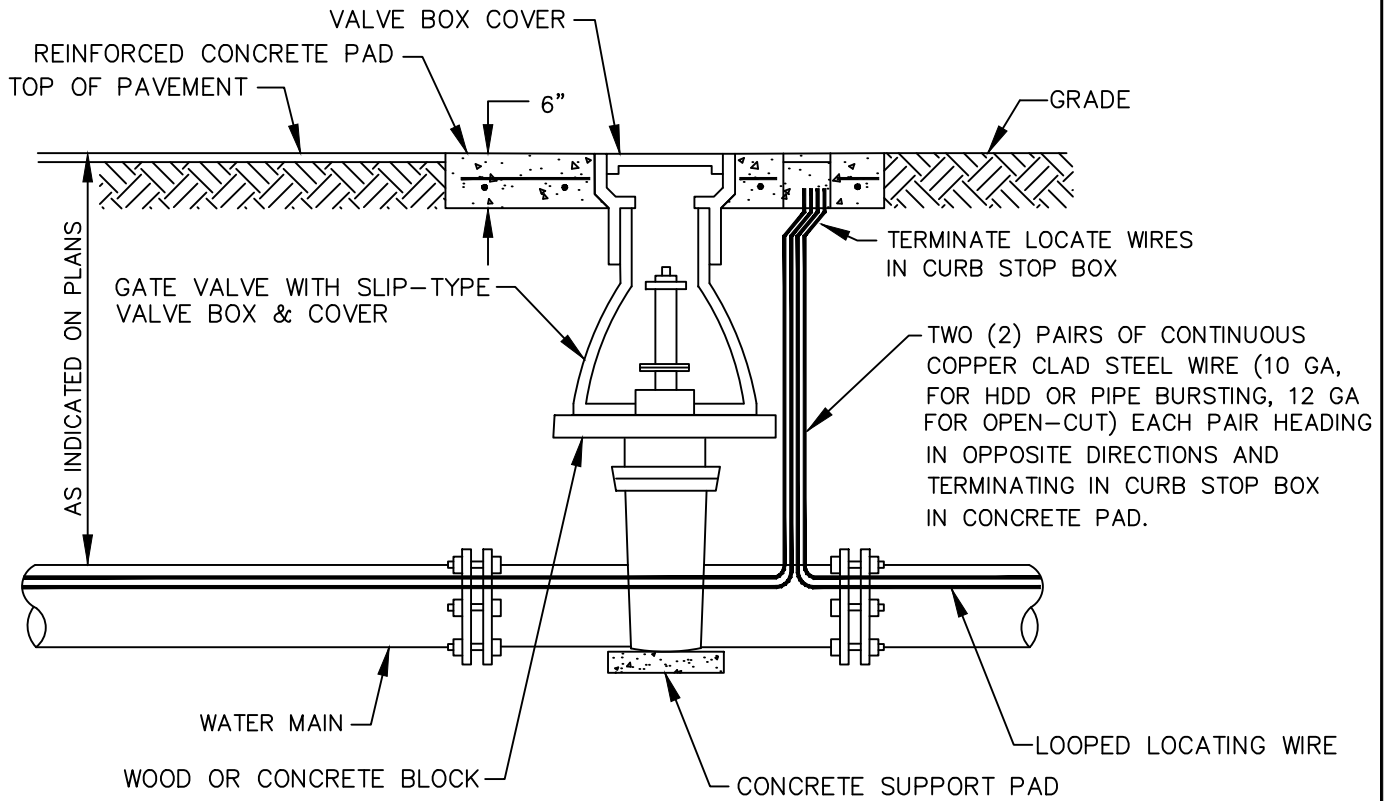
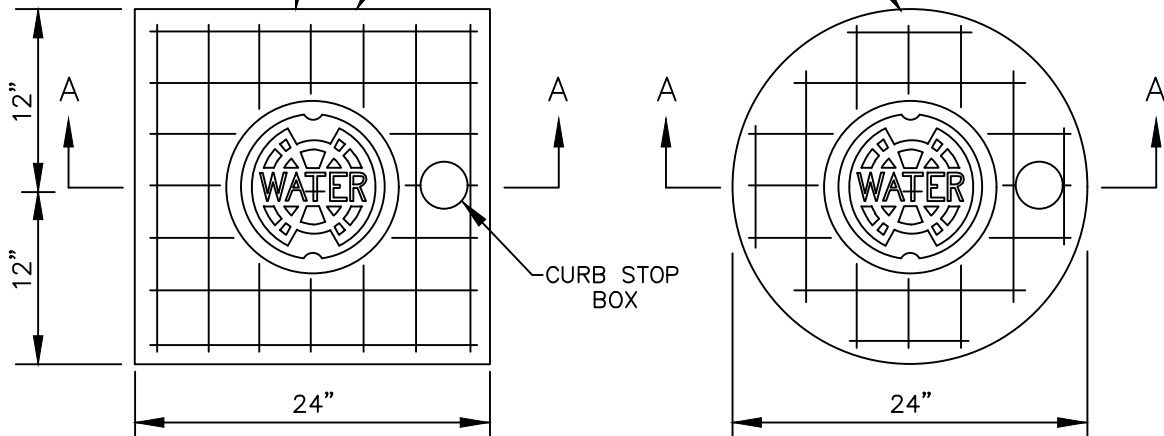

SECTION A-A

N.T.S.

Notes :

1. Circular or square concrete pad required for all valve box installations.
2. Cast iron valve boxes shall be firmly supported and centered and plumb over the operating nut of the valve. Valve box cover shall be flush with the surface of finished pavement or grade or at such other level as may be directed by the Department.
3. "Blue" Water Valve locate markers required for all valve installations.
4. Brass identification disks per Detail 3.06 required for all valve installations.

TAMPA WATER DEPARTMENT	APPROVED	REVISED	VALVE INSTALLATION W/VALVE BOX & PAD FOR PLASTIC PIPE	3.02
	Sept. 2011	_____		

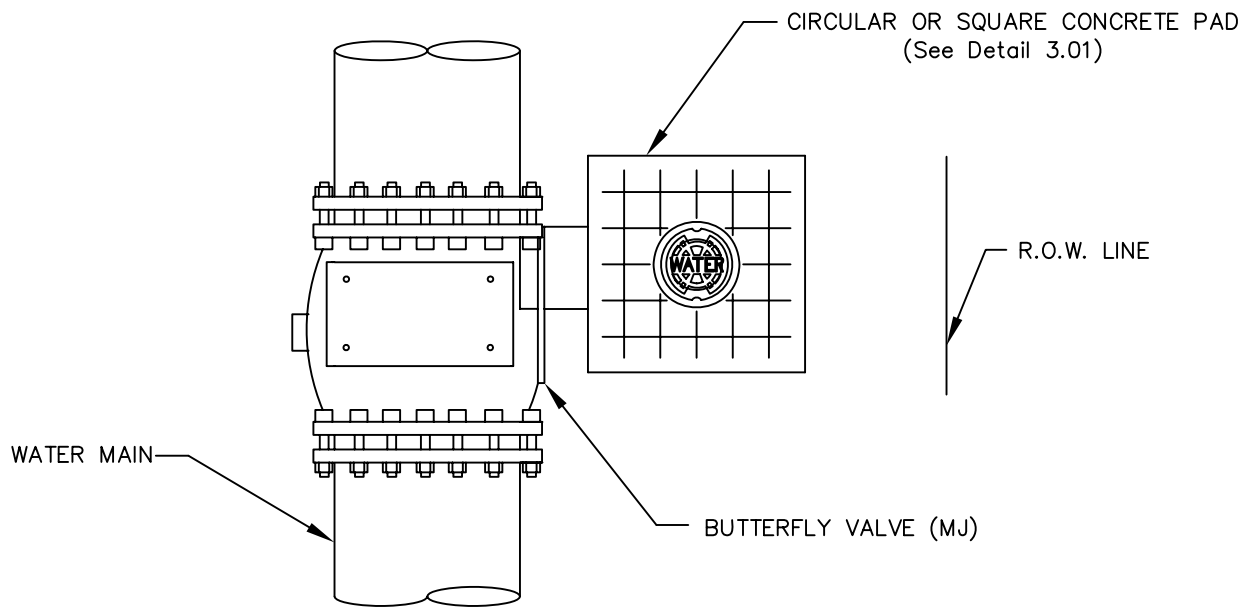

PLAN

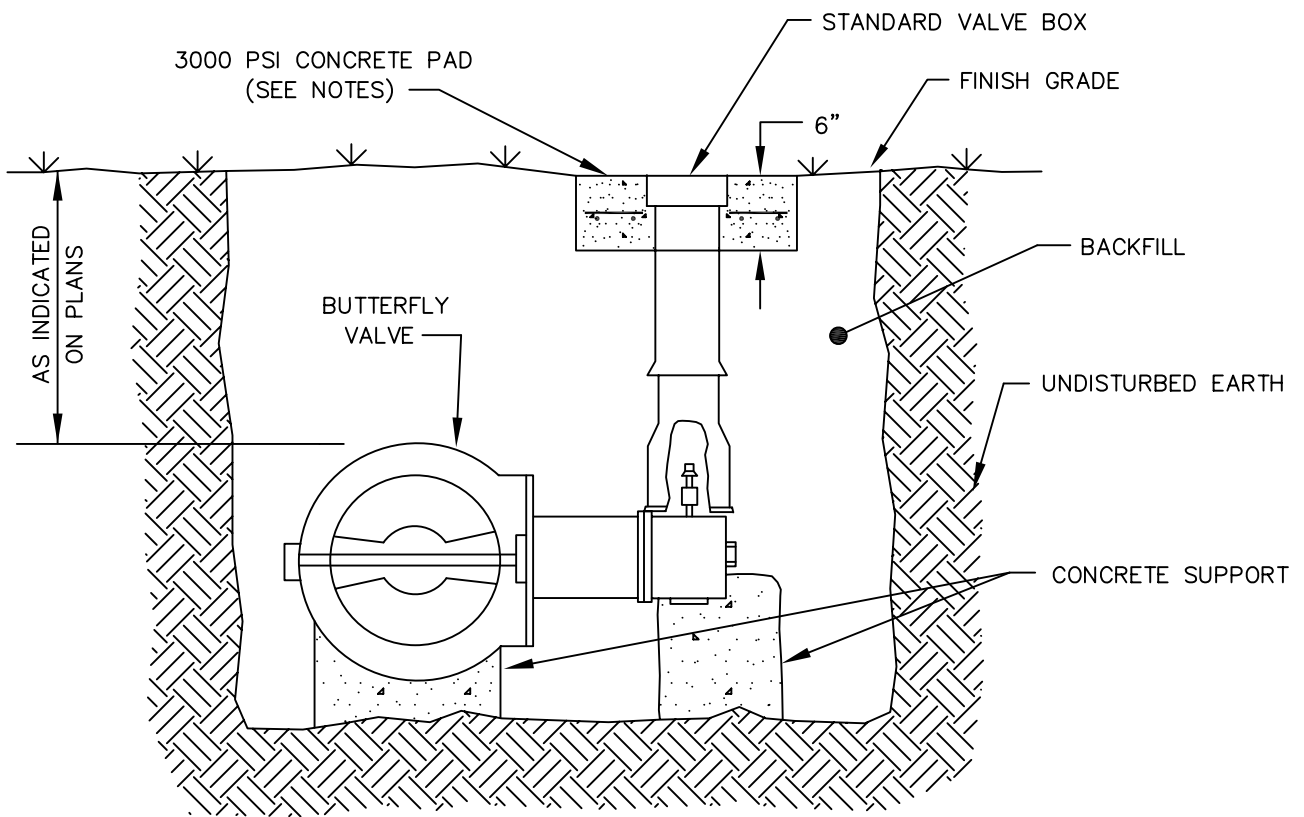

SECTION

Notes:

1. Circular or Square concrete pads for valve box and concrete supports as specified in detail above shall be furnished with all butterfly valve installations.
2. Orient valve so operator is located on the side of the pipe nearest the right-of-way line.

TAMPA WATER DEPARTMENT	APPROVED Sept. 2011	REVISED _____ _____	BUTTERFLY VALVE INSTALLATION W/VALVE BOX & PAD	3.03
------------------------------	----------------------------	-------------------------------	--	------

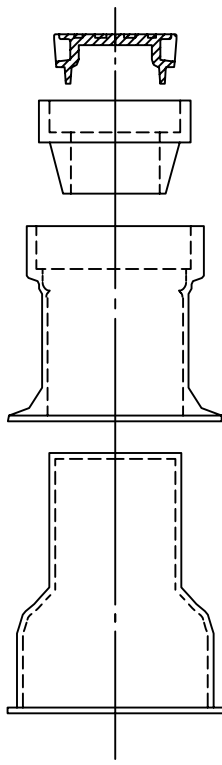

VALVE BOX ASSEMBLY

VALVE BOX COVER

RISER

TOP SECTION

BOTTOM SECTION

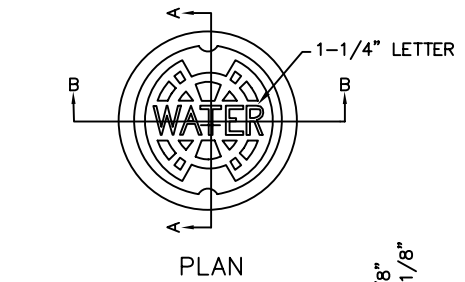

PLAN

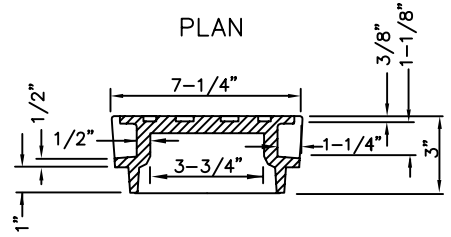

SECTION A-A

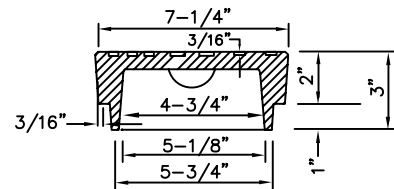

SECTION B-B

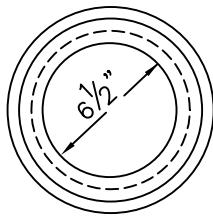

PLAN

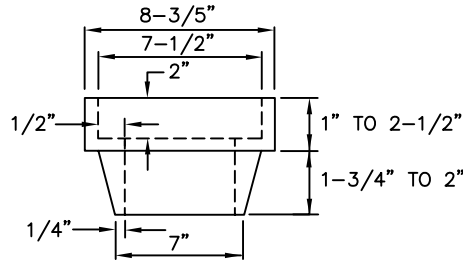

SIDE VIEW

RISER

VALVE BOX COVER

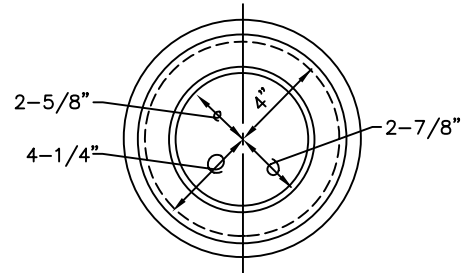

PLAN

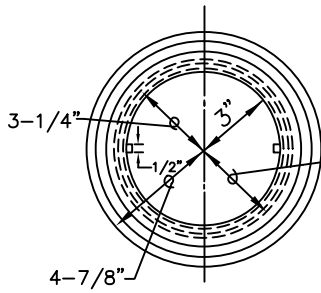

PLAN

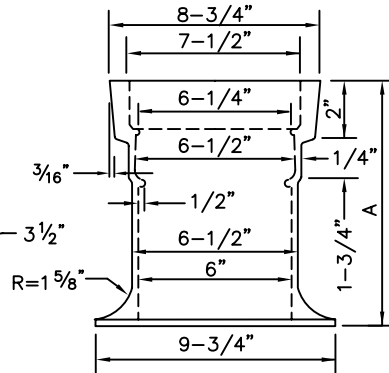

SIDE VIEW

TOP SECTION

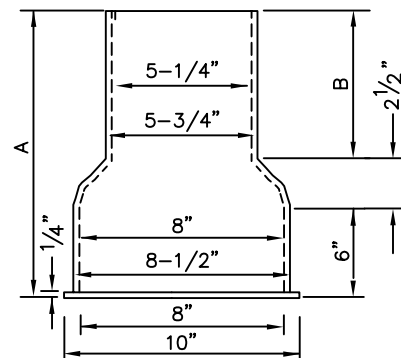

SIDE VIEW

BOTTOM SECTION

TOP SECTION	SIZE	A
	10"	10"
	16"	16"

BOTTOM SECTION	SIZE	A	B
	15"	15"	6-1/2"
	24"	24"	15-1/2"
	36"	36"	27-1/2"

TAMPA
WATER
DEPARTMENT

APPROVED
Sept. 2011

REVISED

VALVE BOX, SLIP-TYPE

3.04

TO PROTECT VALVE BOX LOCATION DURING CLEARING & GRUBBING

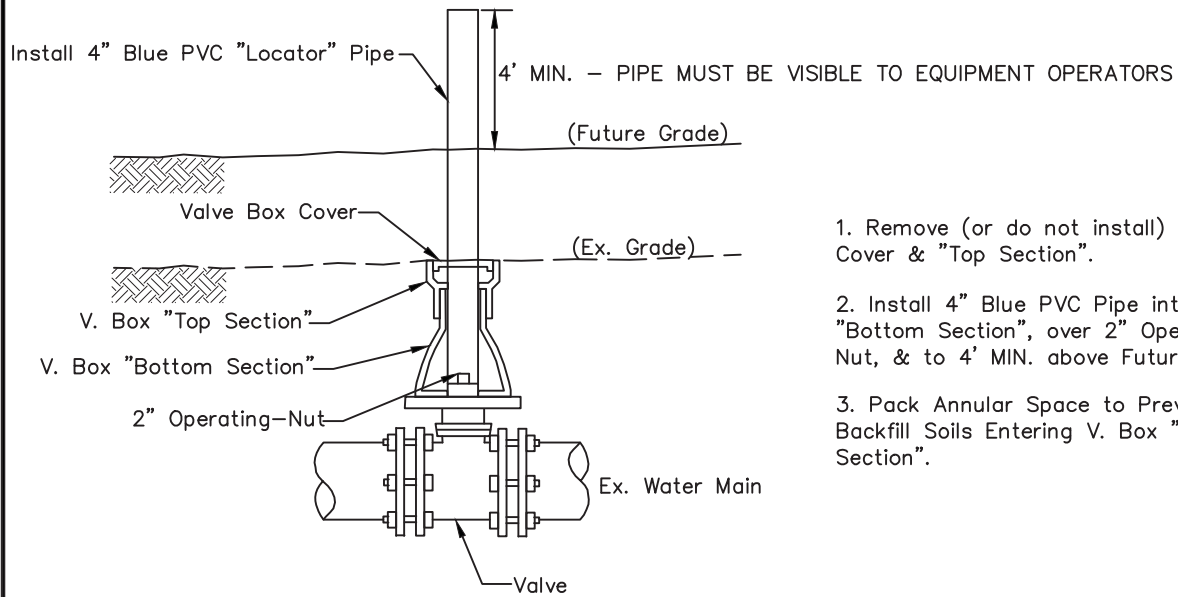

1. Remove (or do not install) V. Box Cover & "Top Section".
2. Install 4" Blue PVC Pipe into V. Box "Bottom Section", over 2" Operating-Nut, & to 4' MIN. above Future Grade.
3. Pack Annular Space to Prevent Backfill Soils Entering V. Box "Bottom Section".

TO ADJUST HEIGHT OF VALVE BOX FOR CHANGED GRADE

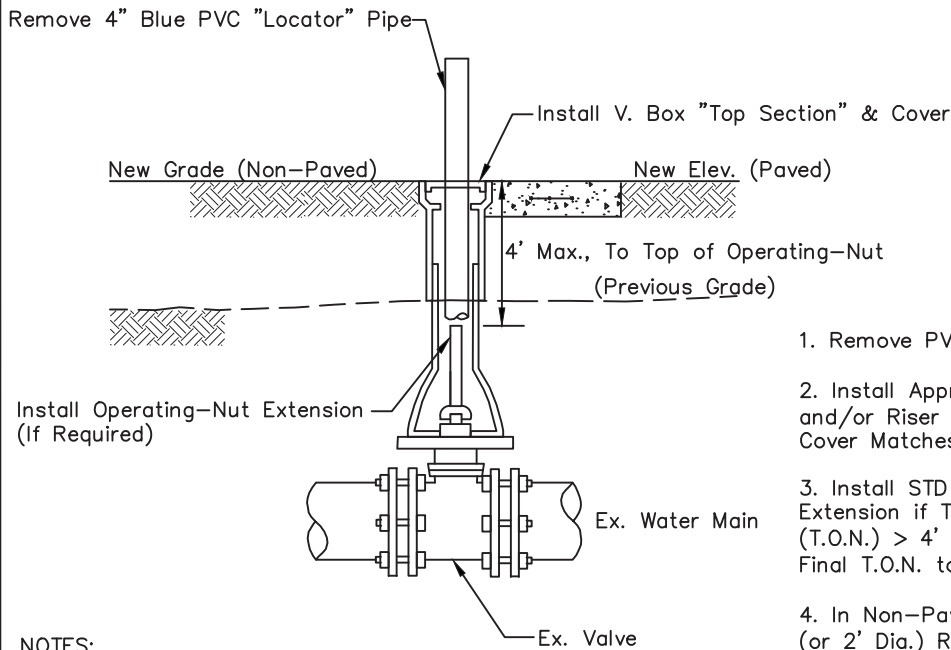

1. Remove PVC Locator Pipe.
2. Install Approved V. Box "Top Section" and/or Riser & Cover, such that Top of Cover Matches New Grade Elevation.
3. Install STD CI Operating-Nut Extension if Top of Operating-Nut (T.O.N.) > 4' below Grade. Final T.O.N. to be < 4' Deep.
4. In Non-Paved Areas, Construct 2'x2' (or 2' Dia.) Reinforced Concrete Pad, per STD. Detail 3.01 (3000 P.S.I. Concrete, 6-Gauge 4"x4" W.W.F.)

NOTES:

1. MATERIALS FOR & INSTALLATION OF VALVE BOXES & PADS SHALL CONFORM TO TAMPA WATER DEPT. SPECIFICATIONS & STD. CONSTRUCTION DETAILS (DETAILS 3.01 & 3.03)

TAMPA WATER DEPARTMENT	APPROVED	REVISED	VALVE BOX (V. BOX) ADJUSTMENTS FOR GRADE CHANGE	3.05
	Dec. 2011	____		

NOTE:

1. ALL MATERIALS SHALL BE IN ACCORDANCE WITH THE LATEST T.W.D. APPROVED MATERIAL SPECIFICATIONS.
2. IF VALVE IS LOCATED WITHIN A SIDEWALK CONCRETE COLLAR MAY BE ELIMINATED AND DISK SET FLUSH DIRECTLY IN SIDEWALK.
3. BRONZE DISK REQUIRED FOR ALL VALVES AND DUMMY BOXES.

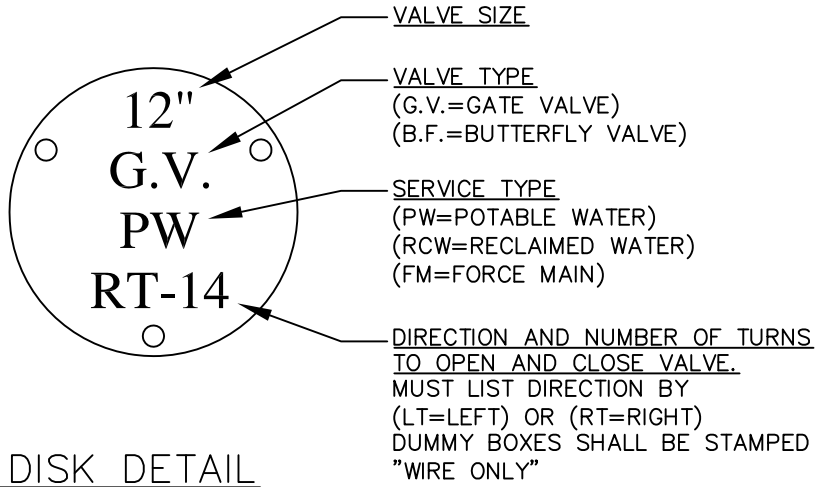

BRONZE DISK DETAIL

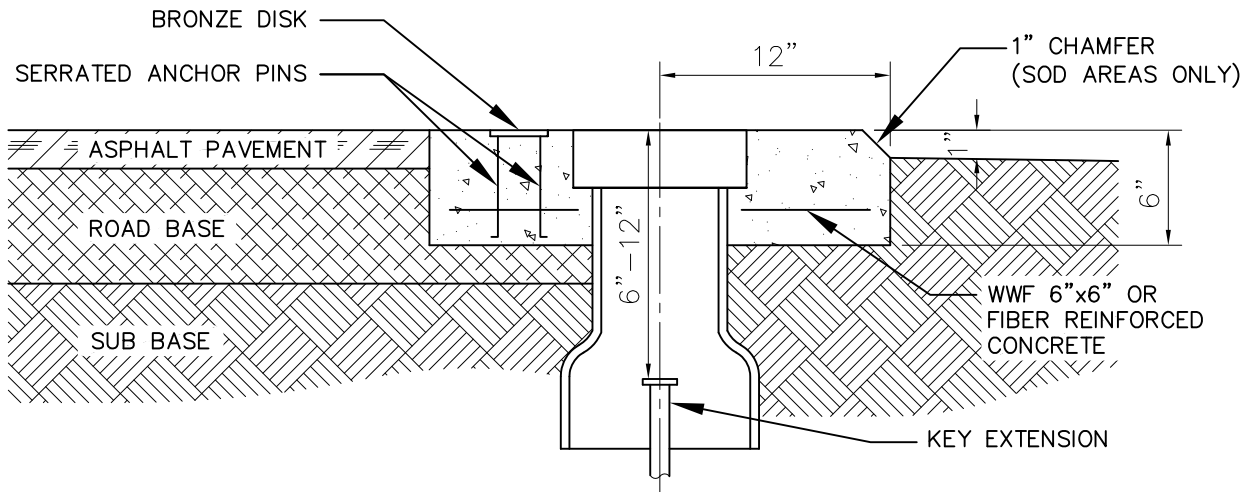

SECTION A-A

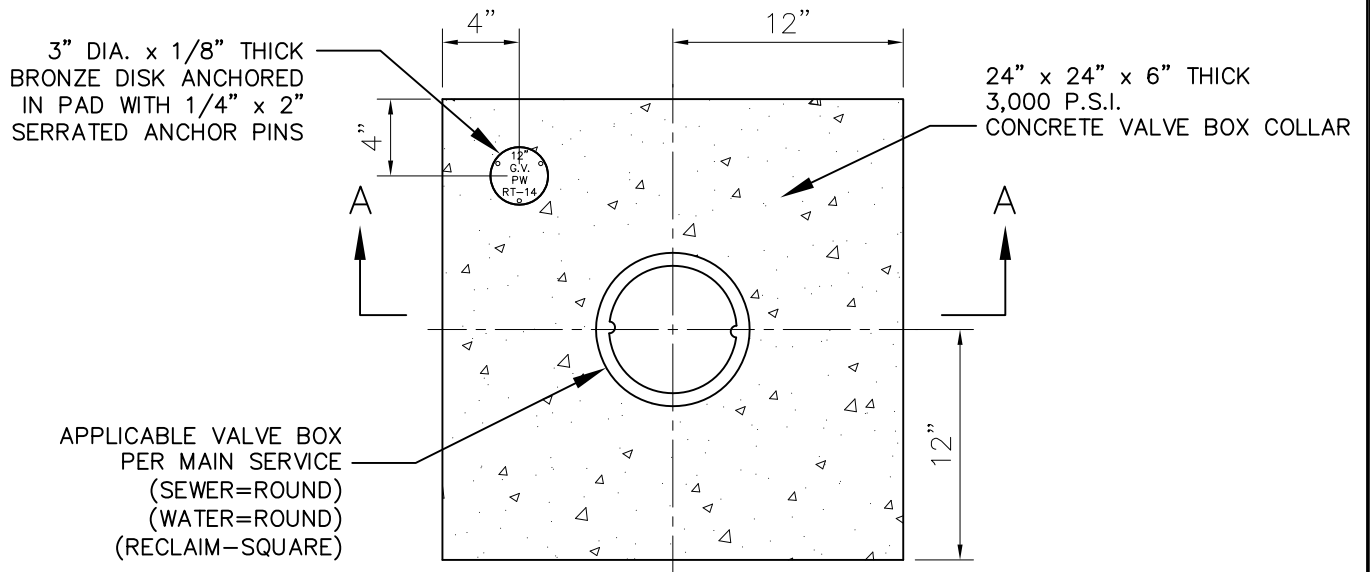

PLAN VIEW

TAMPA WATER DEPARTMENT	APPROVED	REVISED	CONCRETE VALVE BOX COLLAR DETAIL	3.06
	_____	MAR 2016 _____		

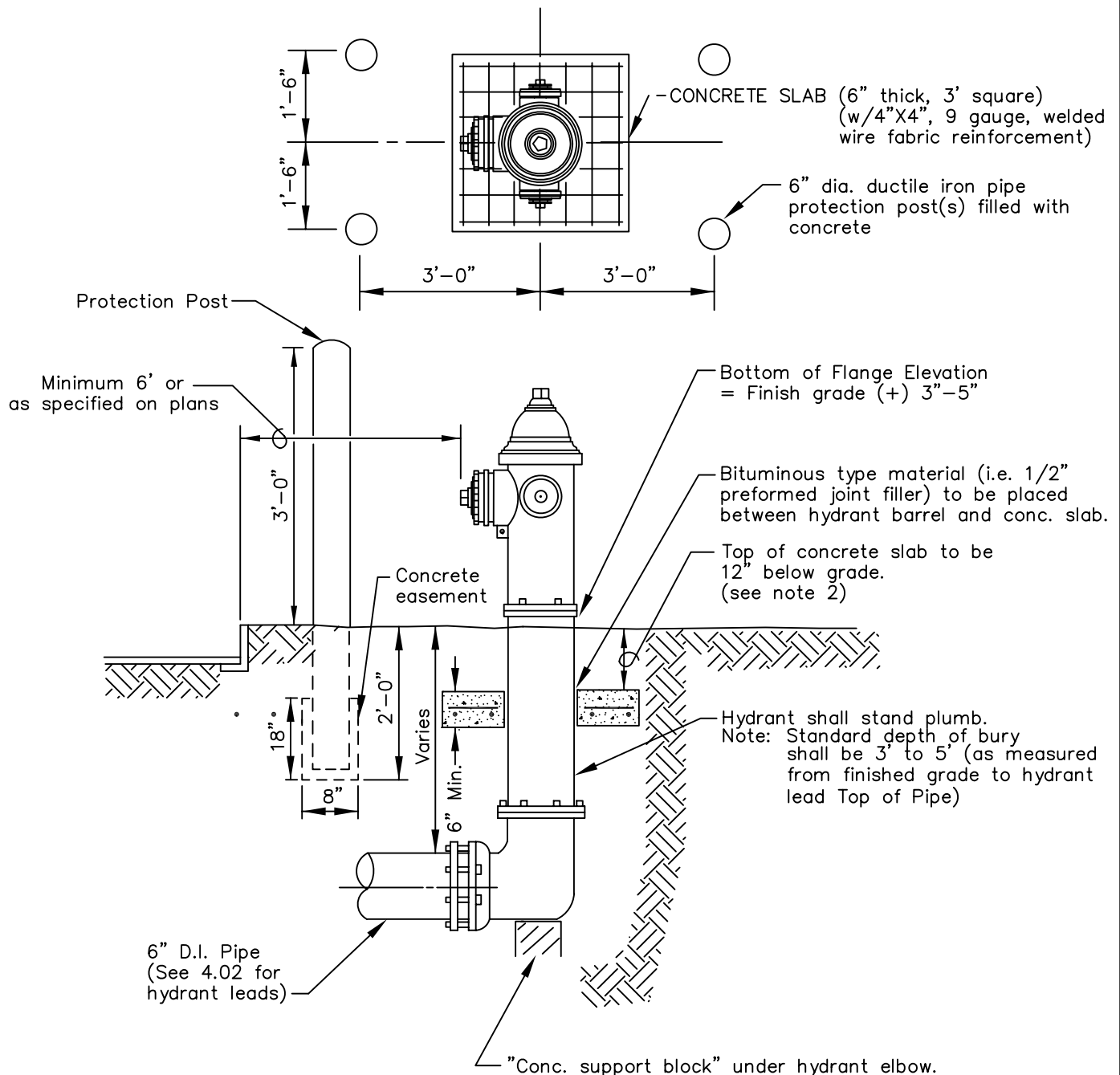

- NOTES:
1. Fire hydrant barrel above the ground line shall be painted with a high-grade enamel paint, Federal Safety yellow (OSHA approved), and the hydrant bonnet shall be painted OSHA green.
 2. Concrete slab may be eliminated in areas where hydrant is set in sidewalk and sidewalk has been installed prior to final acceptance of the hydrant.
 3. Thrust restraint for hydrant:
 - a) hydrant shall be firmly supported under elbow in all methods by support block
 - b) all backfill shall be thoroughly compacted under support block and under thrust collar
 - c) all hydrant leads shall be restrained by Megalugs or equivalent mechanical restraints
 4. Protection posts are required when hydrant is less than 6 feet from edge of pavement, or as directed by the Engineer.
 5. For PVC mains, install concrete support block under all hydrant tees.

TAMPA WATER DEPARTMENT	APPROVED	REVISED	FIRE HYDRANT INSTALLATION	4.01
	Sept. 2011	_____ _____ _____		

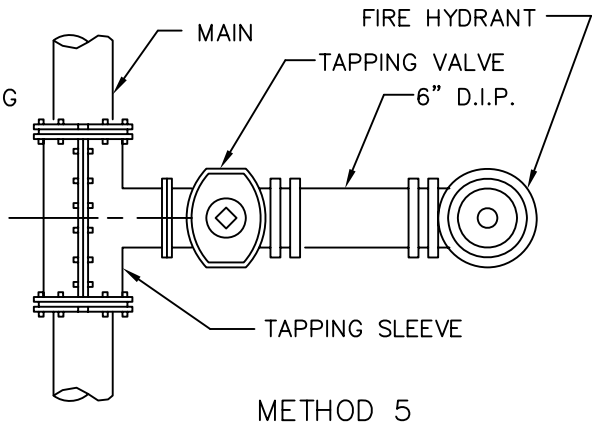
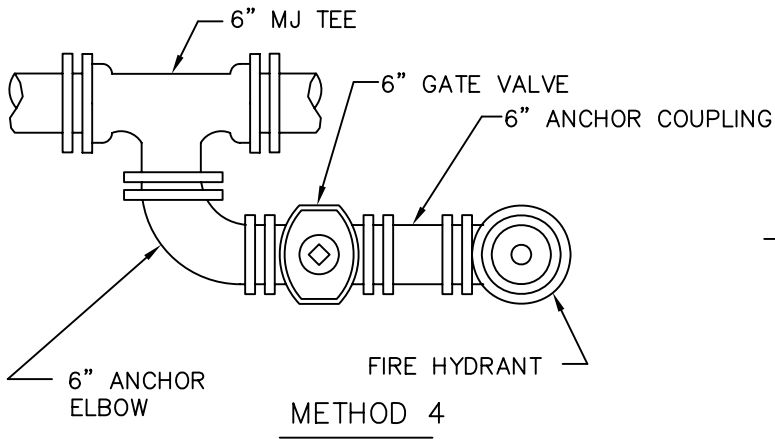
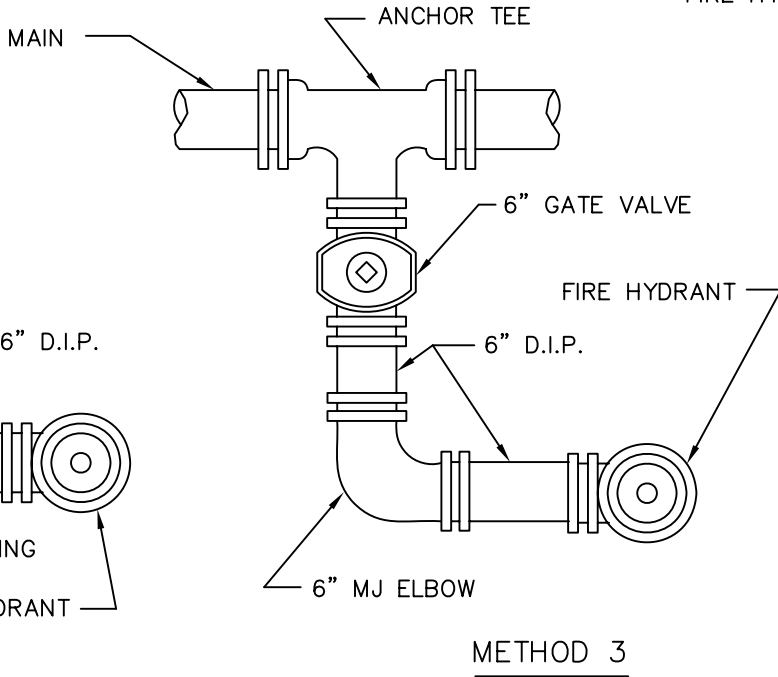
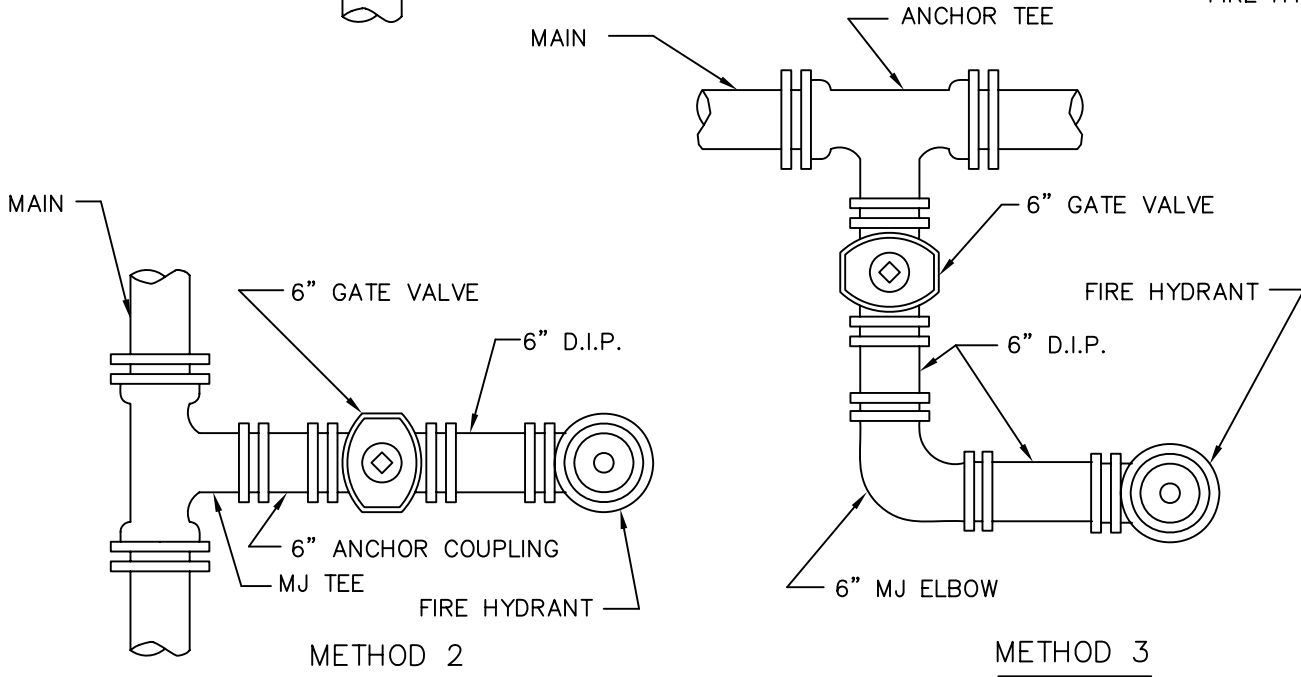
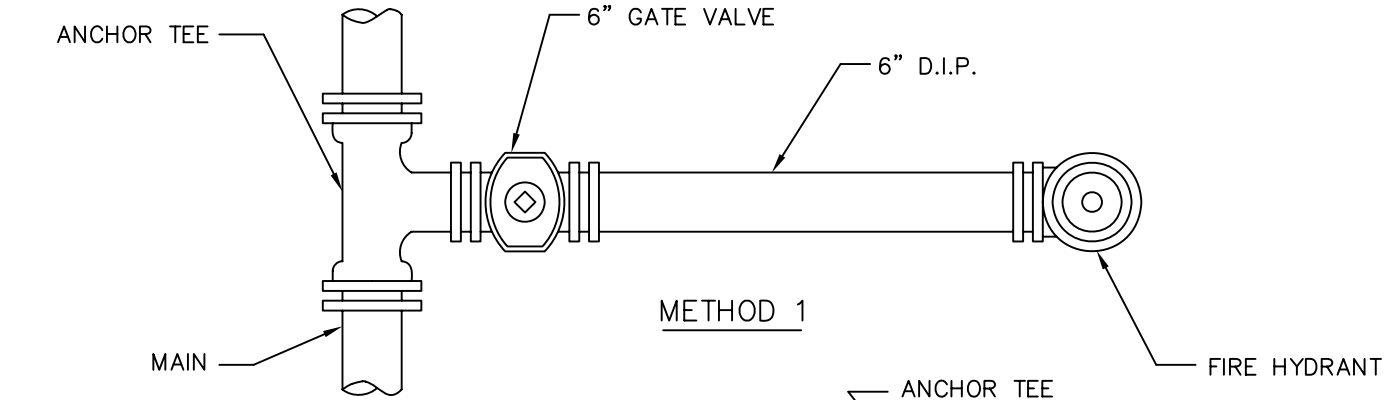

1. Valve shall be set in accordance with Detail 3.01. For hydrant set, see Detail 4.01.
2. All valves shall be anchored to branch of tee on all hydrant installations.
3. All hydrant leads shall be restrained by Megalugs or equivalent.
4. For PVC mains, install concrete support block under hydrant tees.

TAMPA WATER DEPARTMENT	APPROVED	REVISED	FIRE HYDRANT METHODS OF INSTALLATION	4.02
	Sept. 2011	____		

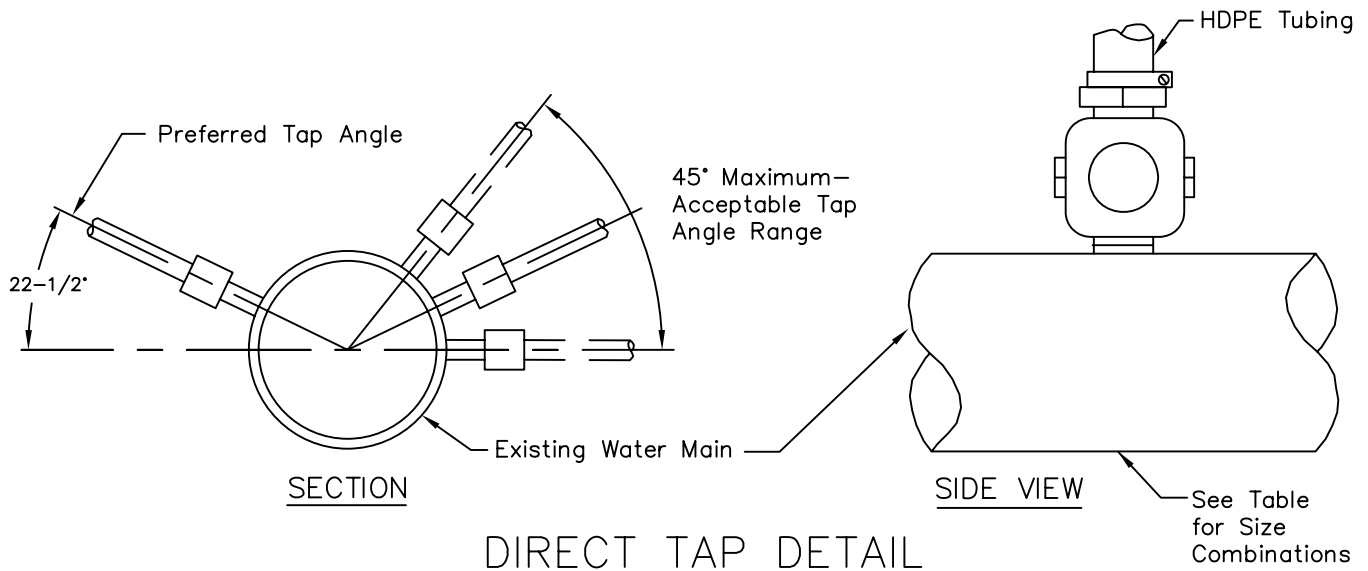

DIRECT TAP DETAIL

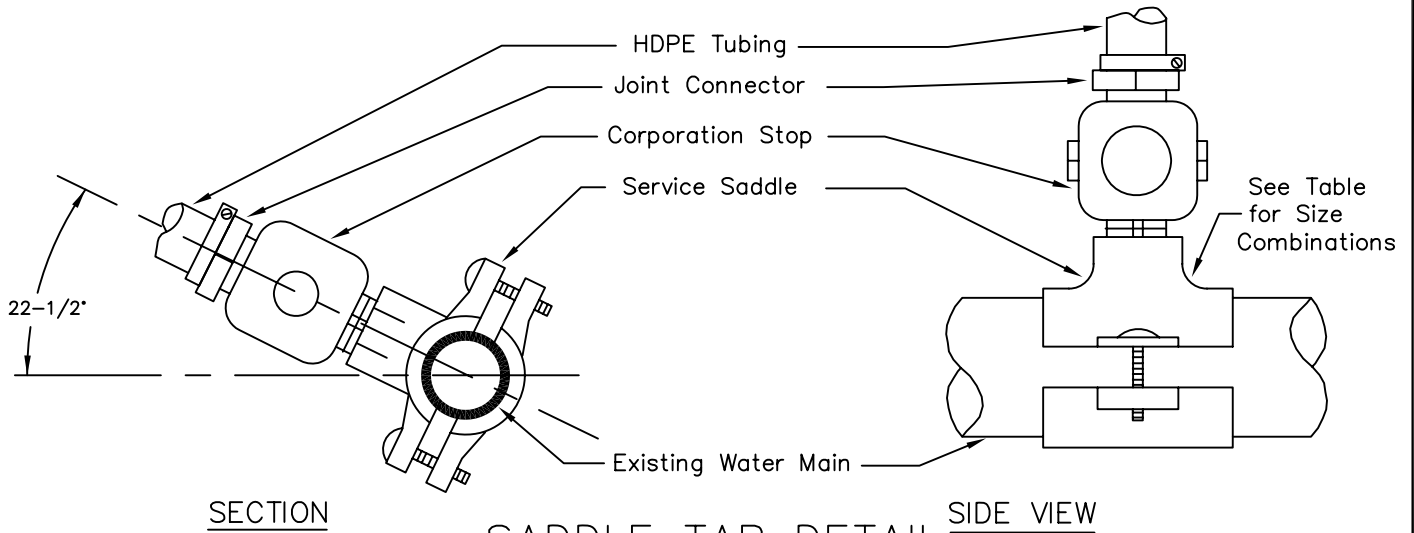

SADDLE TAP DETAIL

PIPE	SIZE	CORPORATION TAP SIZE	
		1"	2"
DI/CI	12"	DT	DT
	8"	DT	SS
	6"	DT	SS
	4"	SS	SS
PVC	2", 2-1/2"	SS	NA
	8" C-900	SS	SS
	6" C-900	SS	SS
	2"-SDR21	SS	NA
OTHER*	12"	SS	SS
	10"	SS	SS
	8"	SS	SS
	6"	SS	SS
	4"	SS	NA
	3"	SS	NA
	2", 2-1/2"	SS	NA

LEGEND

DT- Direct Tap Can be Allowed
 SS- Service Saddle is Required
 NA- Not Allowed
 *Asbestos Cement, Steel, Galvanized Iron Pipe, Non Std PVC, etc.

TAMPA
 WATER
 DEPARTMENT

APPROVED
Sept. 2011

REVISED

TAPPING DETAIL FOR
 3/4", 1", 1-1/2" & 2"
 W/DI, CI, OR PVC PIPE

5.01

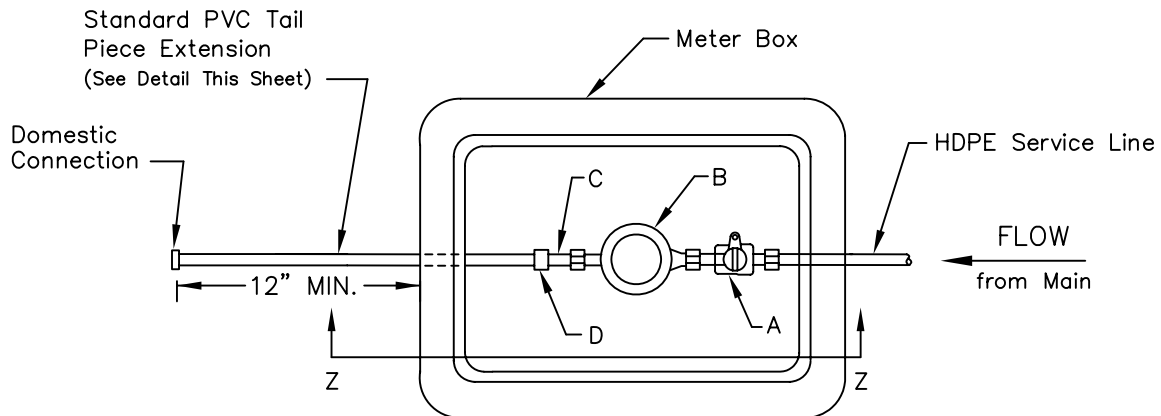

PLAN VIEW

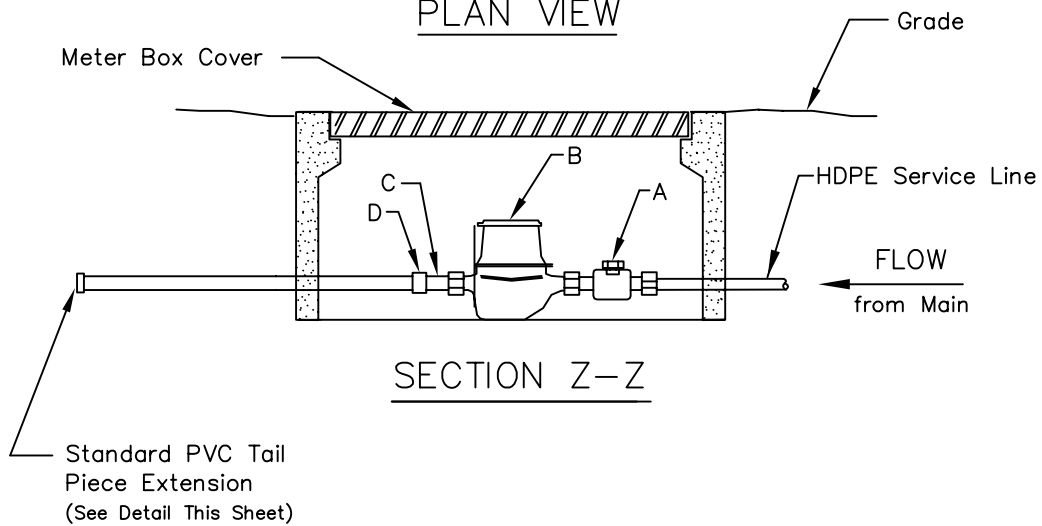

SECTION Z-Z

METER INSTALLATION

-PARTS LIST-

ITEM	DESCRIPTION
A	HDPE CJ X METER, SWIVEL NUT (CURB STOP)
B	METER
C	BRASS METER COUPLING
D	*PVC FIP X WELD COUPLING

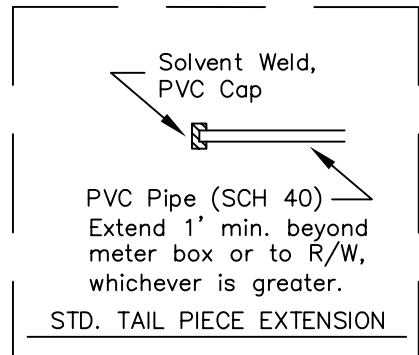

* All PVC pipe and fittings shall be SCH 80 except for standard tail piece section which will be SCH 40.

NOTE: Parts list is for standard installation; actual parts required may vary as directed by the Engineer.

TAMPA WATER DEPARTMENT	APPROVED	REVISED	SINGLE METER SET DETAIL 3/4", 1", 1-1/2", 2"	5.02
	Sept. 2011	_____		

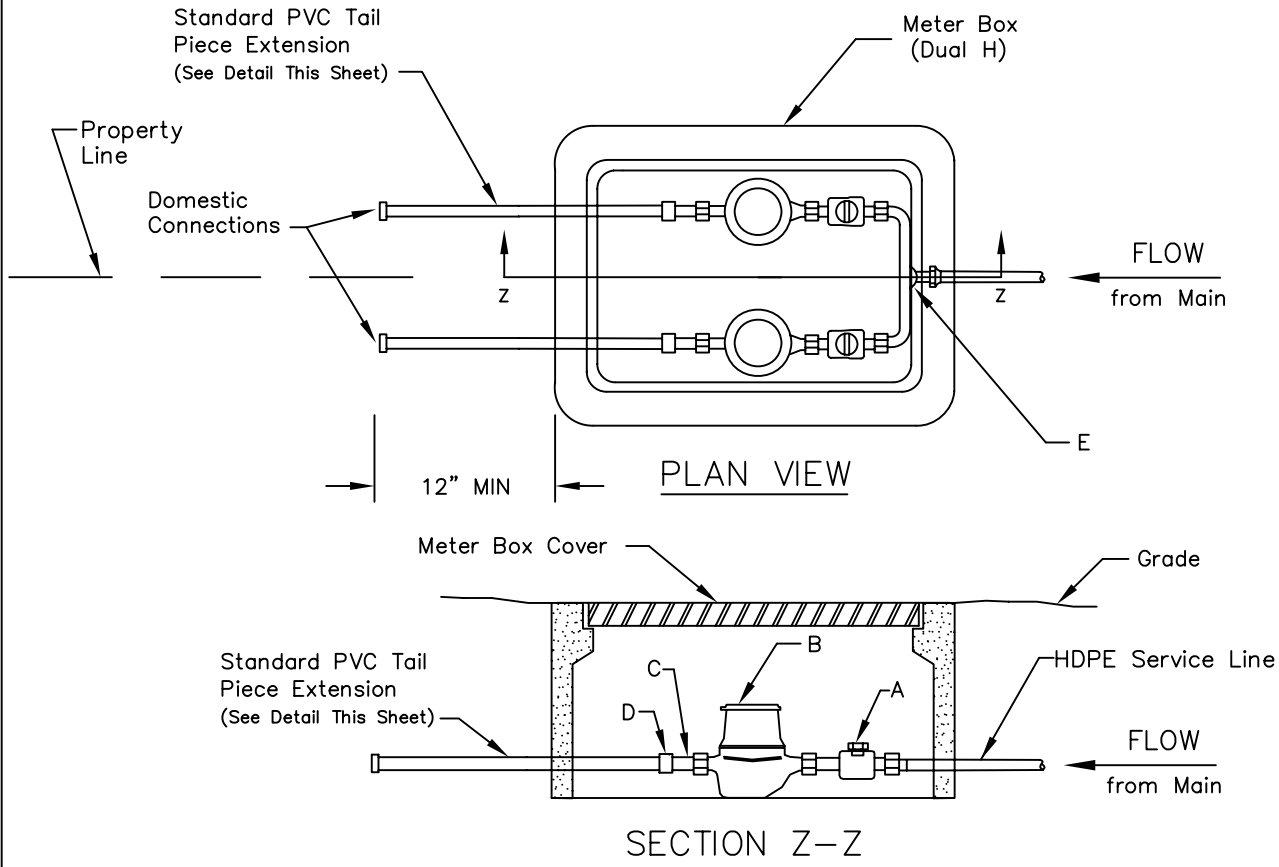

METER INSTALLATION
-PARTS LIST-

<u>ITEM</u>	<u>DESCRIPTION</u>
A	FIP CURB X METER SWIVEL NUT (CURB STOP)
B	METER
C	METER COUPLING
D	*PVC FIP X WELD COUPLING
E	MIP X HDPE CJ BRANCH COUPLING

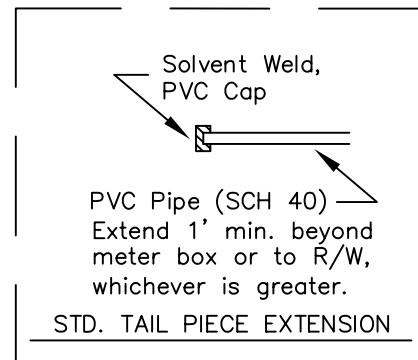

* All PVC pipe and fittings shall be SCH 80 Except for standard tail piece section which will be SCH 40.

NOTE: Parts list is for standard installation; actual parts required may vary as directed by the Engineer.

TAMPA WATER DEPARTMENT	APPROVED	REVISED	DUAL METER SET DETAIL 3/4" & 1"	5.03
	Sept. 2011	_____		

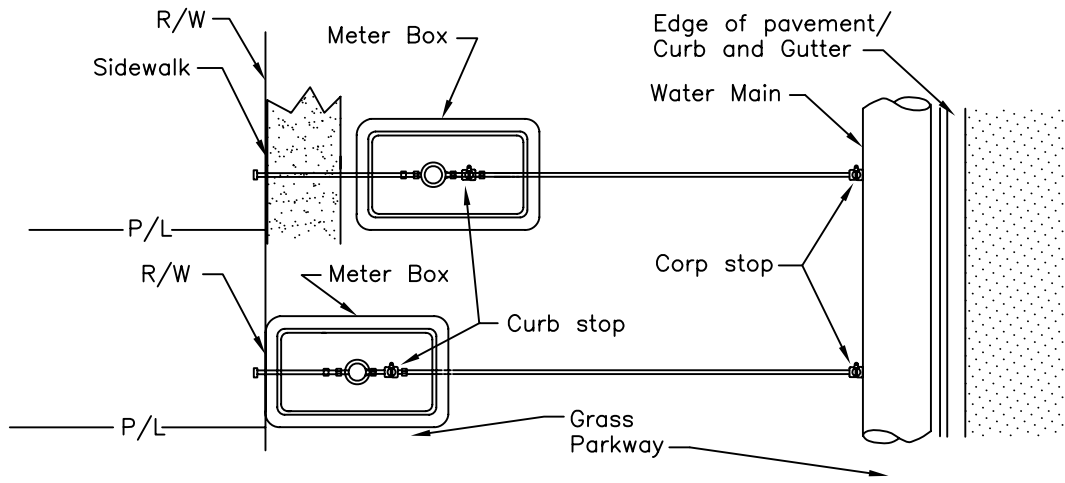

PLAN - SINGLE METER

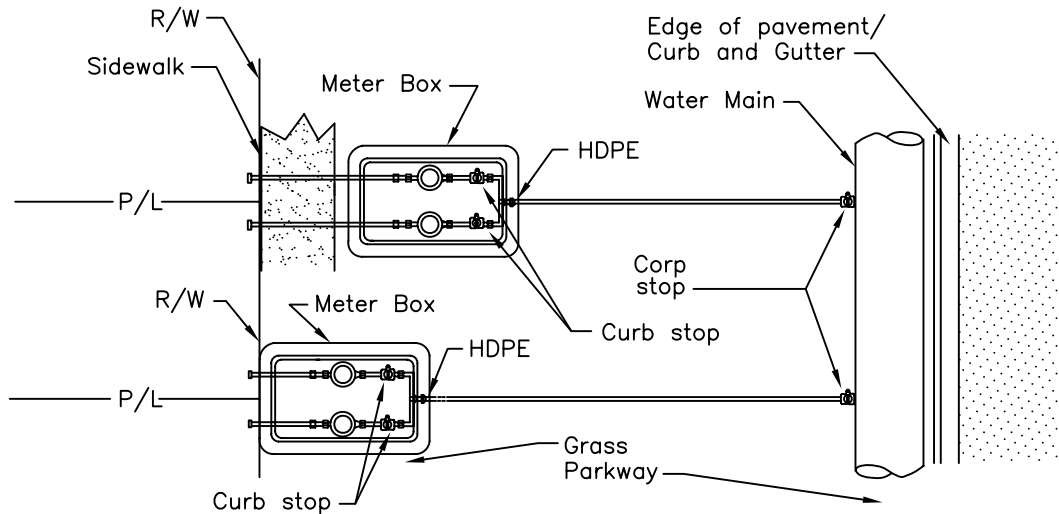

PLAN VIEW - DUAL METER

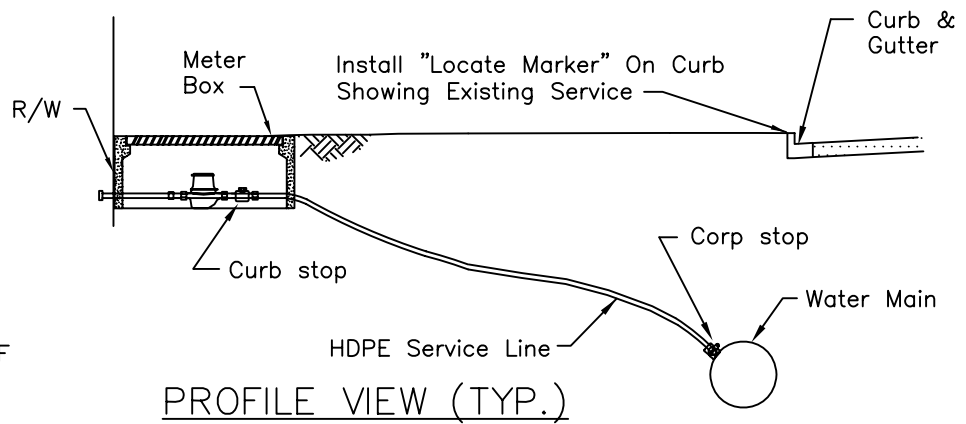

PROFILE VIEW (TYP.)

DO NOT INSTALL METER WITHIN SIDEWALK. WHEN SIDEWALK EXISTS, INSTALL METER ON STREET SIDE OF SIDEWALK OR WHERE DIRECTED BY ENGINEER.

* Line size applicable for DDCVA

SINGLE METER SIZE (inches)	SERVICE LINE SIZE (inches) (0-15')	DUAL METER SIZE (inches)	SERVICE LINE SIZE (inches) (0-15')
3/4	1	3/4	2
1	1	1	2
1-1/2	2	1-1/2	n/a
2*	2	2	n/a

(Feet refer to distance from water main to meter)

TAMPA WATER DEPARTMENT	APPROVED	REVISED	SINGLE & DUAL METERED SERVICE - SHORT SIDE 3/4", 1", 1-1/2" AND 2"	5.04
	Sept. 2011	____ _		

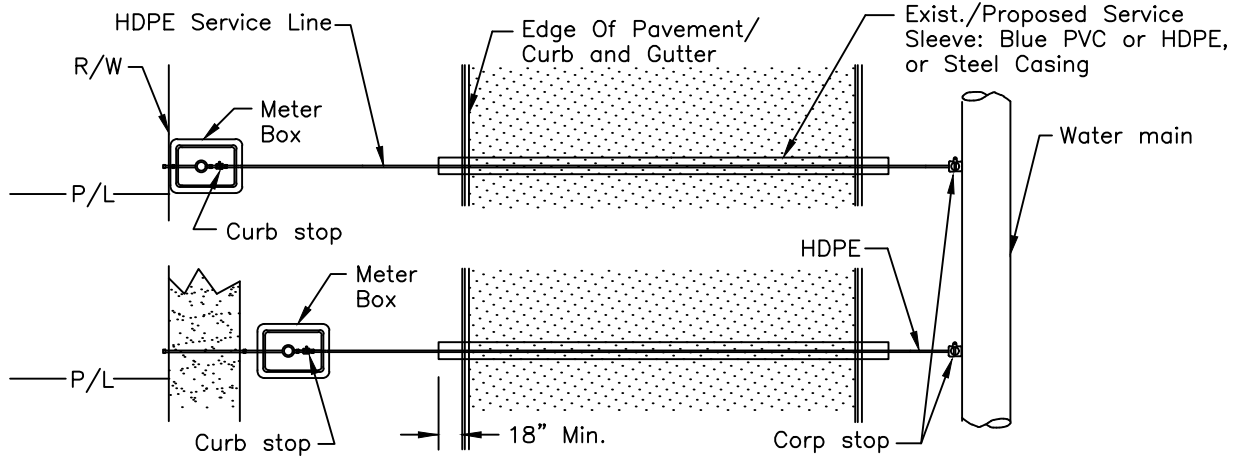

PLAN VIEW - SINGLE METER

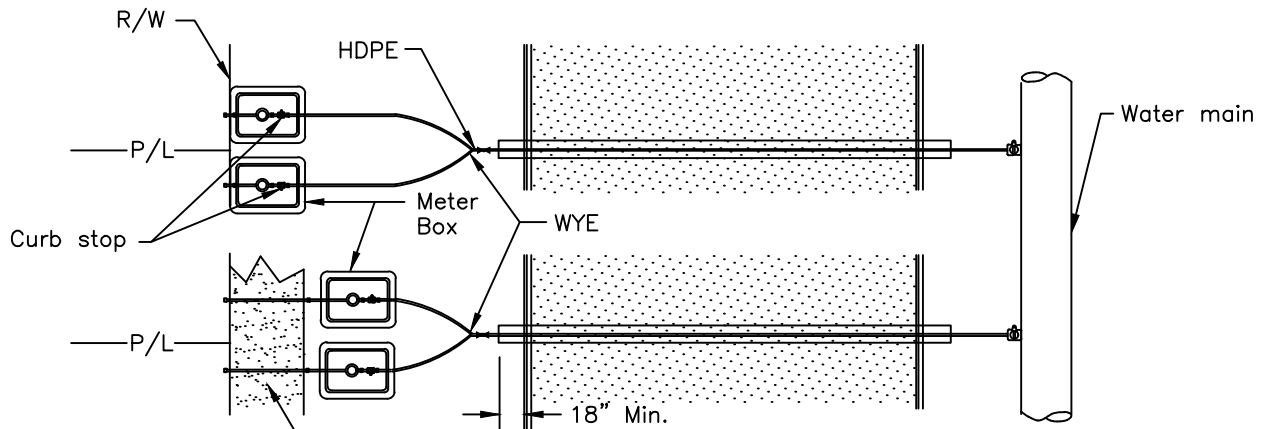

PLAN VIEW - DUAL METER

DO NOT INSTALL METER WITHIN SIDEWALK. WHEN SIDEWALK EXISTS, INSTALL METER ON STREET SIDE OF SIDEWALK OR WHERE DIRECTED BY ENGINEER.

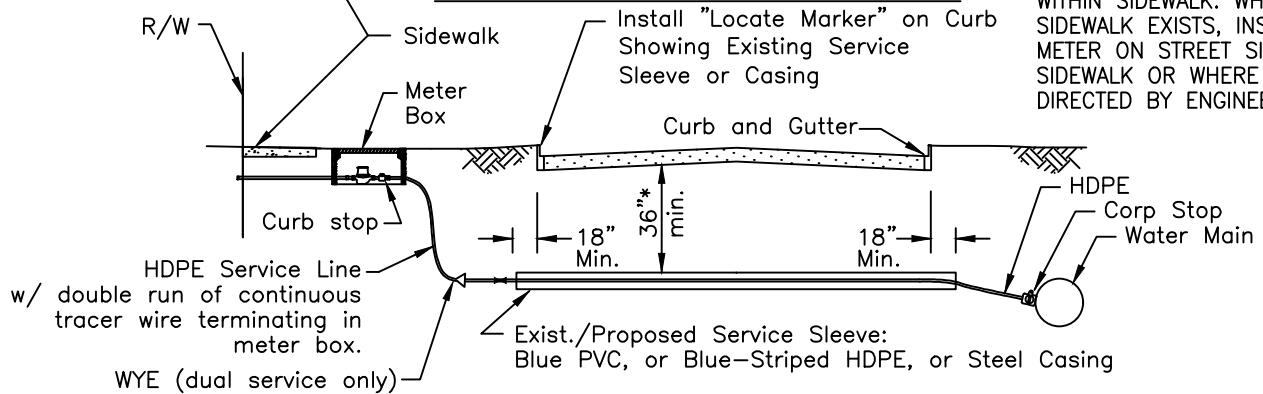

PROFILE VIEW (TYP.)

CASING SPECIFICATION:

1. If pushed-SCH 40 steel pipe (min.)
2. If layed in open trench-SCH 40 steel pipe or SCH 80 PVC solvent weld pipe.

*Or greater, if required by ROW controlling agency

**Line sizes applicable for 2" DDCV

SINGLE METER SIZE (inches)	SERVICE LINE SIZE (inches)		CASING SIZE (inches)
	(15'-80')	(80'-150')	
3/4	1	2	2 / 4
1	2	2	4
1-1/2	2	2	4
2**	4" D.I.P.	4" D.I.P.	12

DUAL METER SIZE (inches)	SERVICE LINE SIZE (inches)		CASING SIZE (inches)
	(15'-80')	(80'-150')	
3/4	2	2	4
1	2	4" D.I.P.	4 / 12
1-1/2	n/a	n/a	n/a
2	n/a	n/a	n/a

(Feet refer to distance from water main to meter)

TAMPA WATER DEPARTMENT	APPROVED	REVISED	SINGLE & DUAL METERED SERVICE - LONG SIDE 3/4", 1", 1-1/2" AND 2"	5.05
	Sept. 2011	_____		

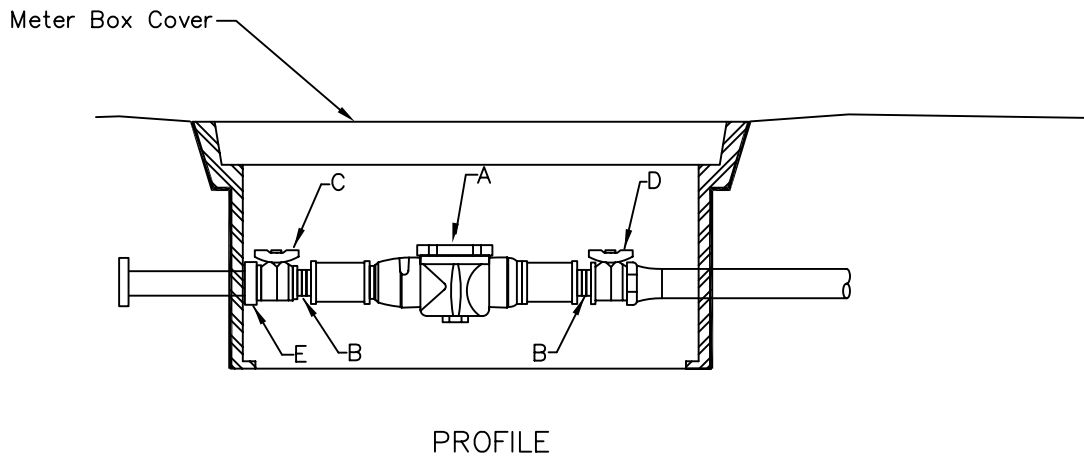
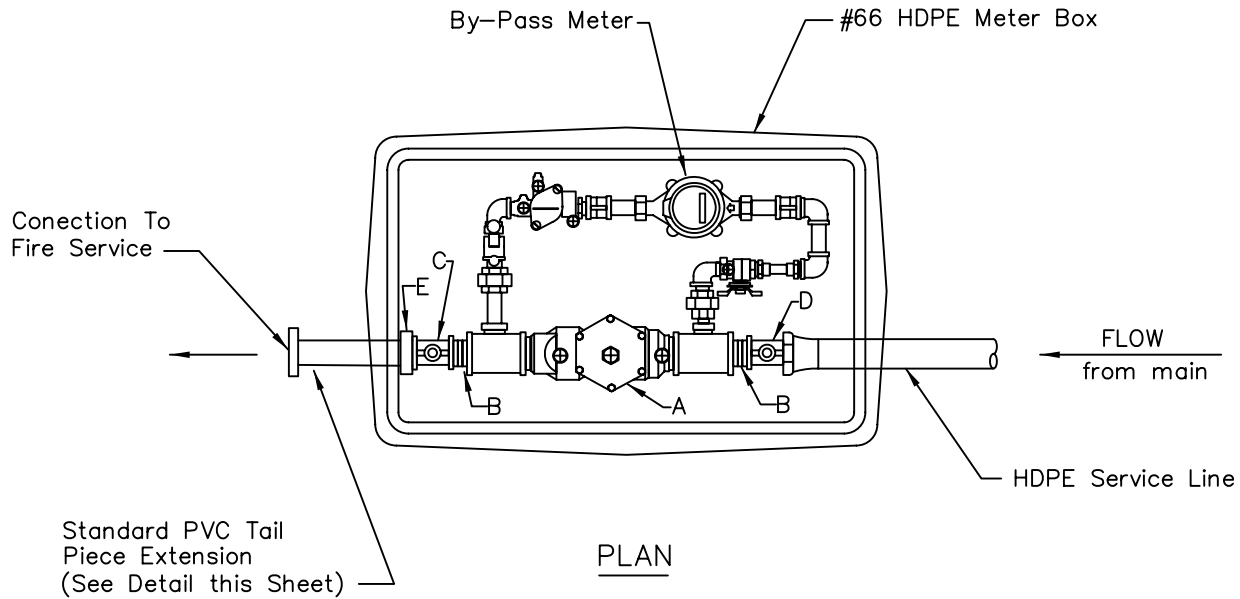

D.C.V. INSTALLATION
-PARTS LIST-

<u>ITEM</u>	<u>DESCRIPTION</u>
A	2" DOUBLE DETECTOR CHECK VALVE
B	2" CLOSE NIPPLE
C	2" CURB STOP (FIP X FIP)
D	2" CURB STOP (FIP X CC)
E	2" SCH 40 PVC MIP X WELD COUPLING

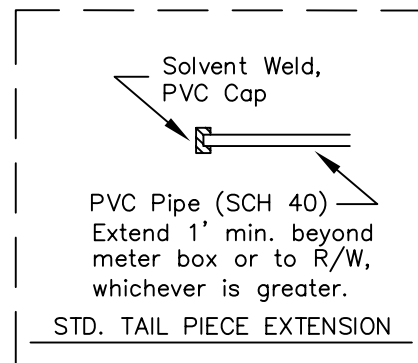

NOTE: Parts list is for standard installation; actual parts required may vary as directed by the Engineer.

TAMPA WATER DEPARTMENT	APPROVED <u>Sept. 2011</u>	REVISED _____ _____ _____	2" DOUBLE DETECTOR CHECK VALVE ASSEMBLY IN METER BOX	5.09
------------------------------	-------------------------------	------------------------------------	--	------

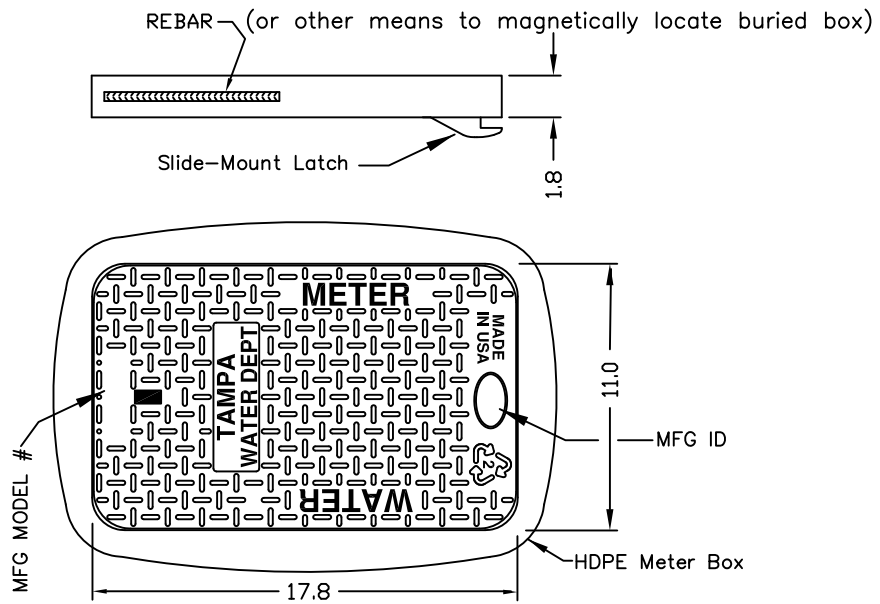

Anti-Float Lid w/Rebar & AMR Snap-lock Slide Mount

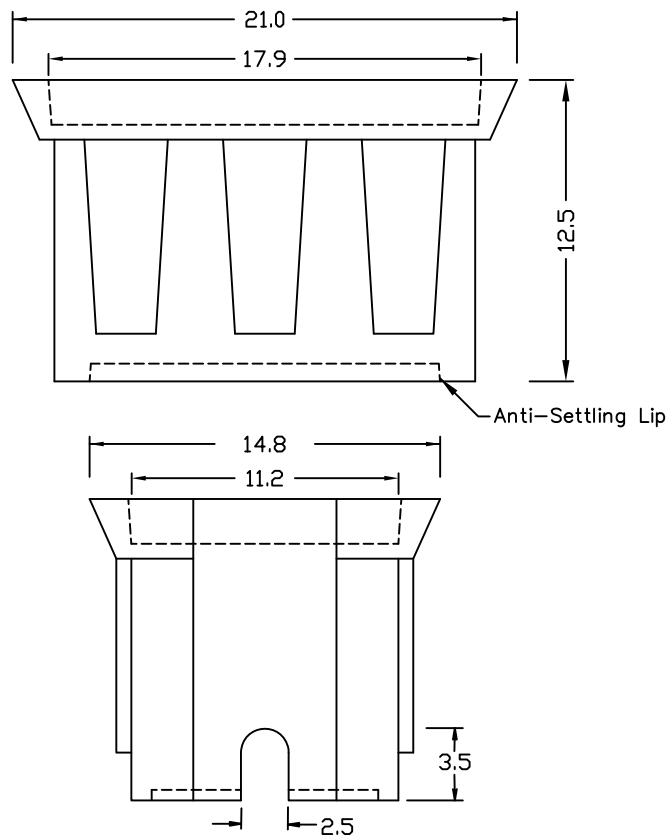

HDPE METER BOX w/LIP

Units = inches
(NTS)

#37 HDPE METER BOX w/ COVER

<p>TAMPA WATER DEPARTMENT</p>	<p>APPROVED Sept. 2011</p>	<p>REVISED RNM 12/2/16</p>	<p>3/4" OR 1" SINGLE SERVICE HDPE METER BOX</p>	<p>5.10A</p>
---------------------------------------	--------------------------------	--------------------------------	---	--------------

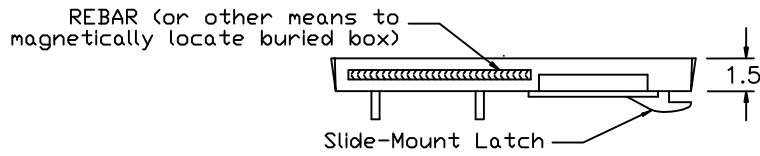
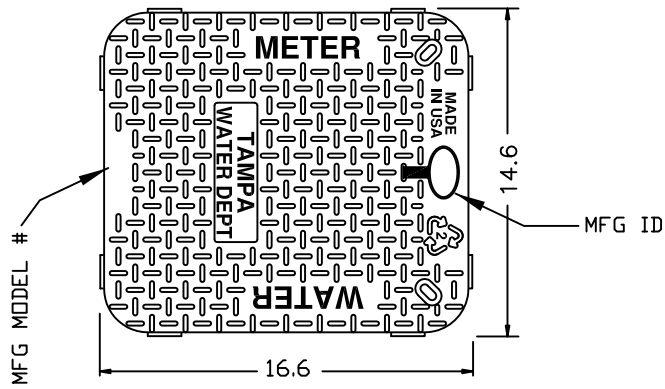

Anti-Float Lid w/Rebar & AMR Snap-lock Slide Mount

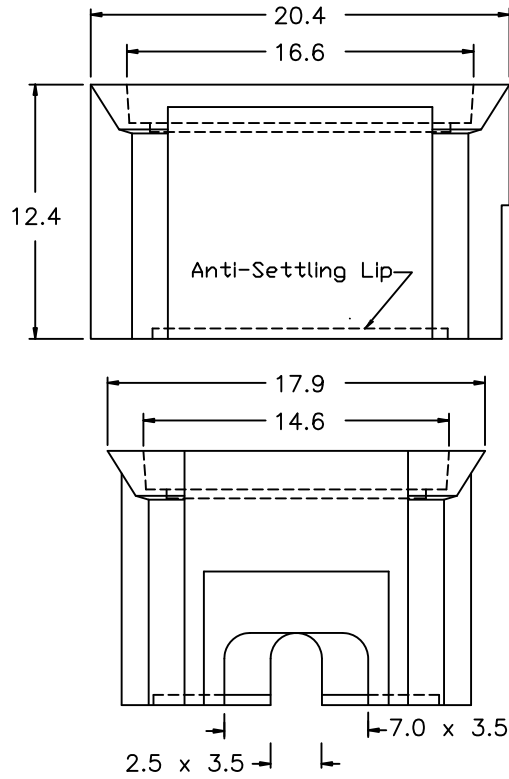

HDPE METER BOX w/LIP

Units = inches
(NTS)

"DUAL-H" HDPE METER BOX w/ COVER

<p>TAMPA WATER DEPARTMENT</p>	<p>APPROVED Sept. 2011</p>	<p>REVISED RNM 12/2/16</p>	<p>3/4" OR 1" DUAL SERVICE HDPE METER BOX</p>	<p>5.11A</p>
---------------------------------------	--------------------------------	--------------------------------	---	--------------

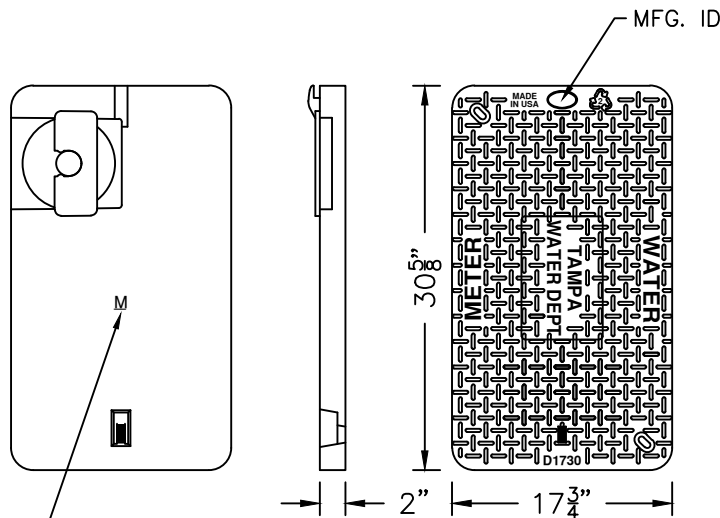

BODY KEY	
H	HEAVY WALL, 1/2"

LID KEY	
AF	ANTI-FLOAT MATERIAL
1	BLACK COLOR
M	MAGNET
A	AMR SLIDE MOUNT
TPA	TAMPA WATER

1730C-AF1MA TPA-LID

MAGNET (OR OTHER MEANS TO MAGNETICALLY LOCATE BURIED BOX)

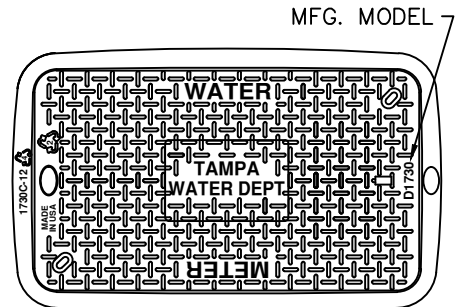

1730CH-12-AF1MA TPA

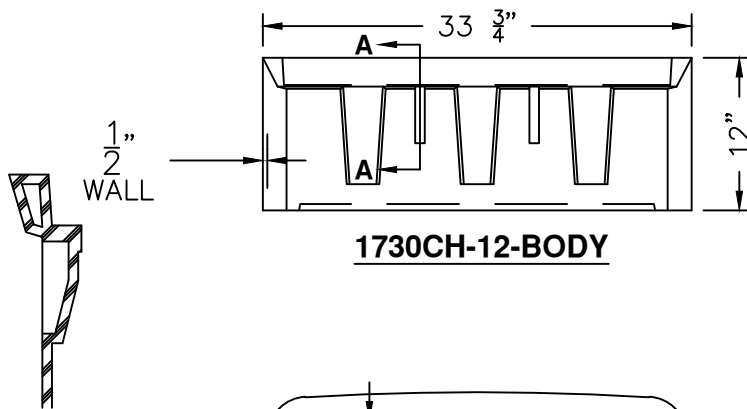

1730CH-12-BODY

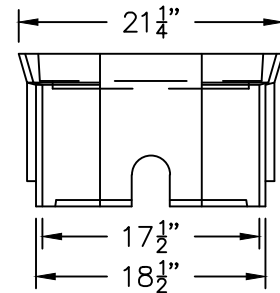

LIFT STRUCTURE SECTION A-A

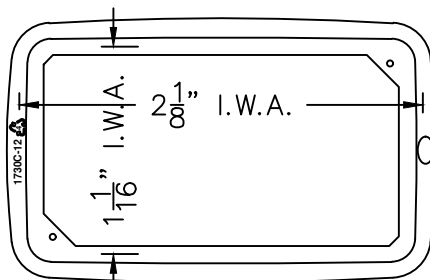

1730CH-12-BODY

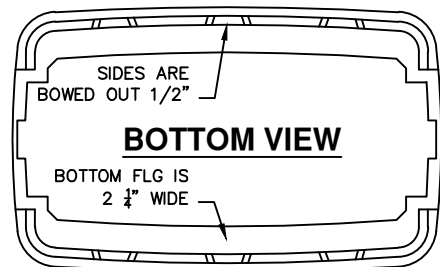

BOTTOM VIEW

BOTTOM FLG IS 2 1/4" WIDE

NOTES

- 1) DIM'S ± 1/8" U.N.O.
- 2) LID MATERIAL: HDPE
- 3) BODY MATERIAL: LLDPE
- 4) WALL THICKNESS: 1/2" MINIMUM
- 5) I.W.A. = INSIDE WORK AREA.
- 6) SNAP LOCK POCKET WILL RECEIVE AMR/AMI DEVICE ENDPOINT. SNAP LOCK SLOT IS 1.80" ± .015" TO ALLOW FOR A FINGER FORCE INSTALL. POCKET HEIGHT IS 15/16" FOR MIN 1/8" AIR GAP.

#66 HDPE METER BOX W/COVER

TAMPA WATER DEPARTMENT	APPROVED	REVISED	1-1/2" & 2" SINGLE SERVICE HDPE METER BOX	5.12A
	Aug. 2017	_____		

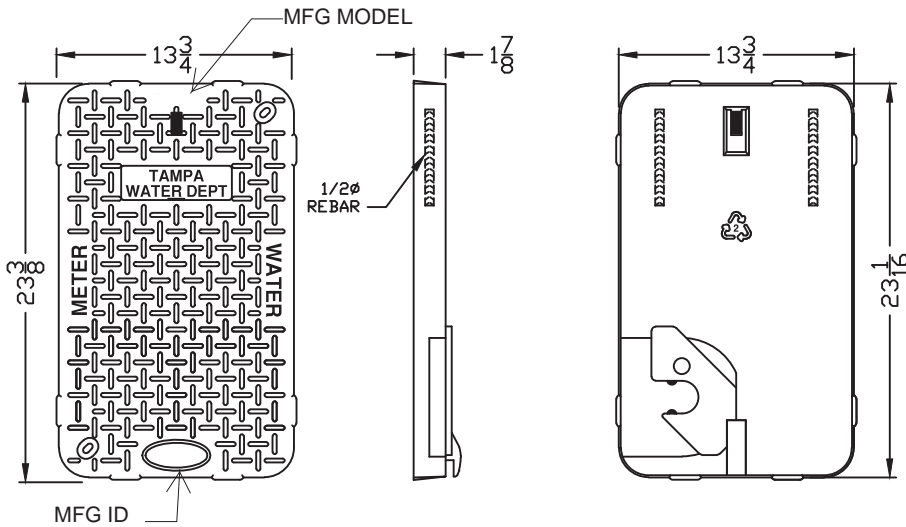

**1324C-AF1EA TPA-LID
(ANTI-FLOAT LID)**

LID KEY	
AF	ANTI-FLOAT MATERIAL
1	BLACK COLOR
E	REBAR, 1/2"
A	AMR SLIDE MOUNT
TPA	TAMPA WATER ENGRAVING

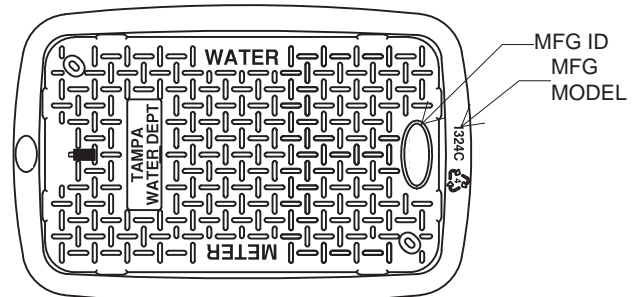
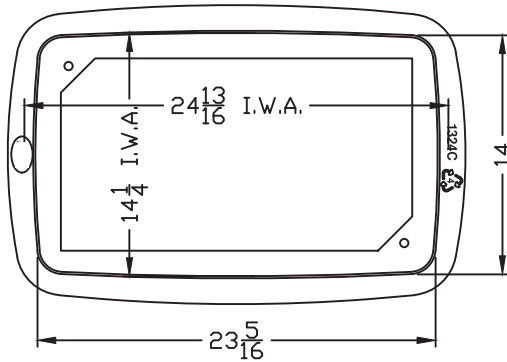

1324CXX-12-AF1EA TPA

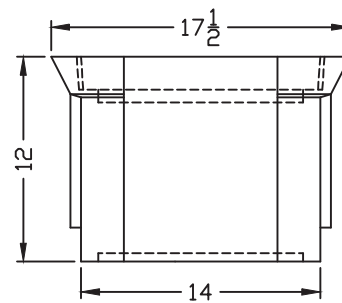
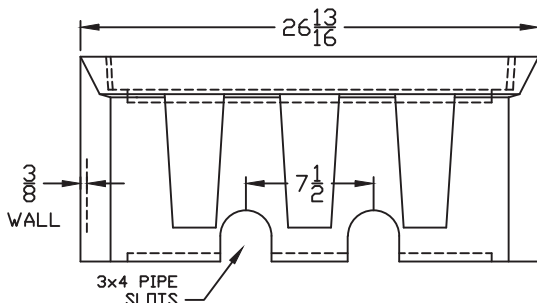

1324CXX-12-BODY

NOTES

- 1) DIM'S ± 1/8" U.N.O.
- 2) LID MATERIAL: ANTI-FLOAT
- 3) BODY MATERIAL: LLDPE
- 4) WALL THICKNESS: 3/8" ± 5%
- 5) I.W.A. = INSIDE WORK AREA
- 6) SNAP LOCK WILL RECEIVE AMR/AMI DEVICE ENDPOINT. SNAP LOCK SLOT DIMENSIONS SHALL BE SUFFICIENT TO ALLOW FOR A FINGER FORCE INSTALL & POCKET HEIGHT SHALL ALLOW A MIN 1/8" AIR GAP.

CITY OF TAMPA

**13" x 24" HDPE METER BOX AND COVER
W/ FOUR MOUSE HOLES**

5.13

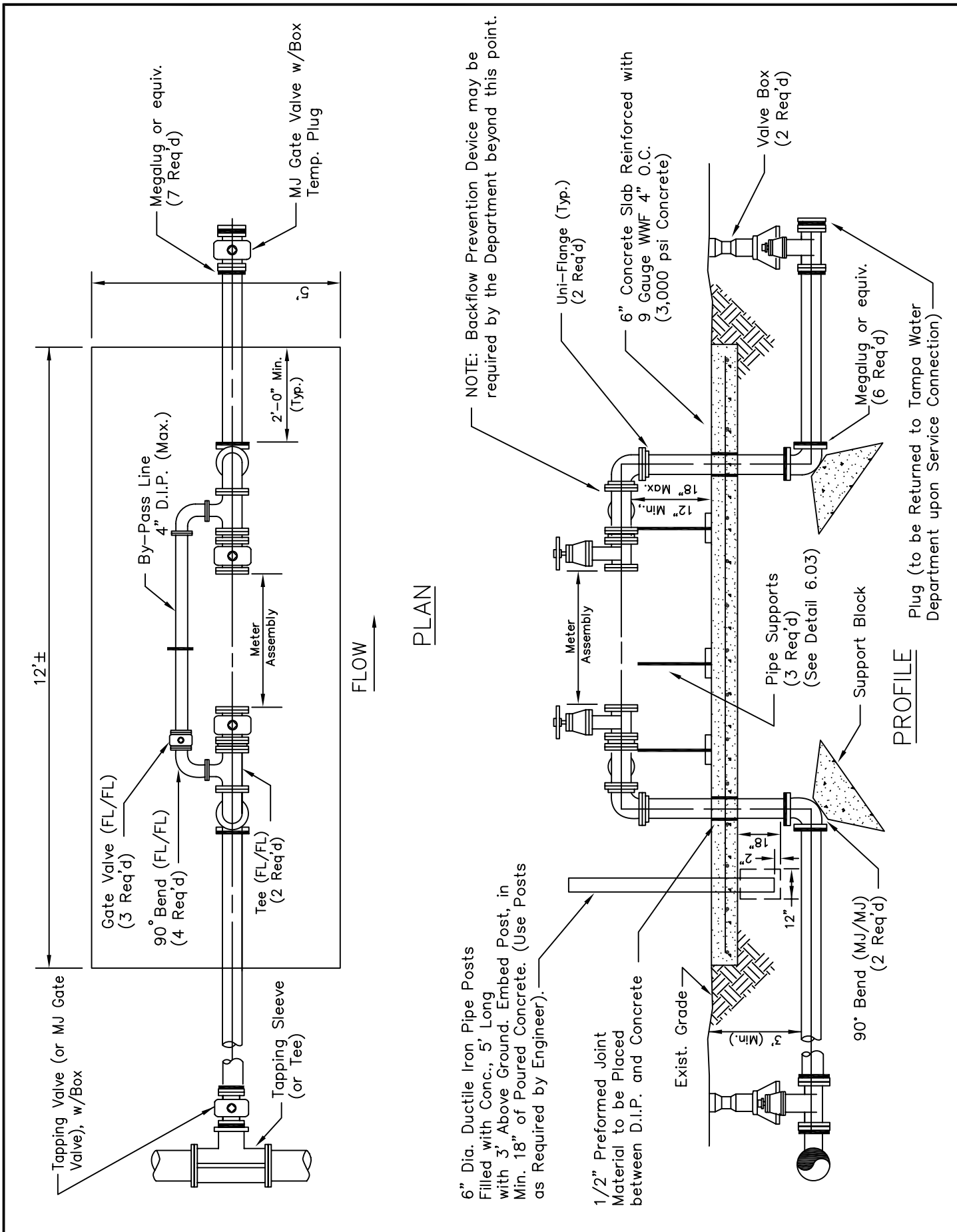

TAMPA WATER DEPARTMENT

APPROVED
Sept. 2011

REVISED

ABOVE GROUND TURBINE METER W/STRAINERS

6.01

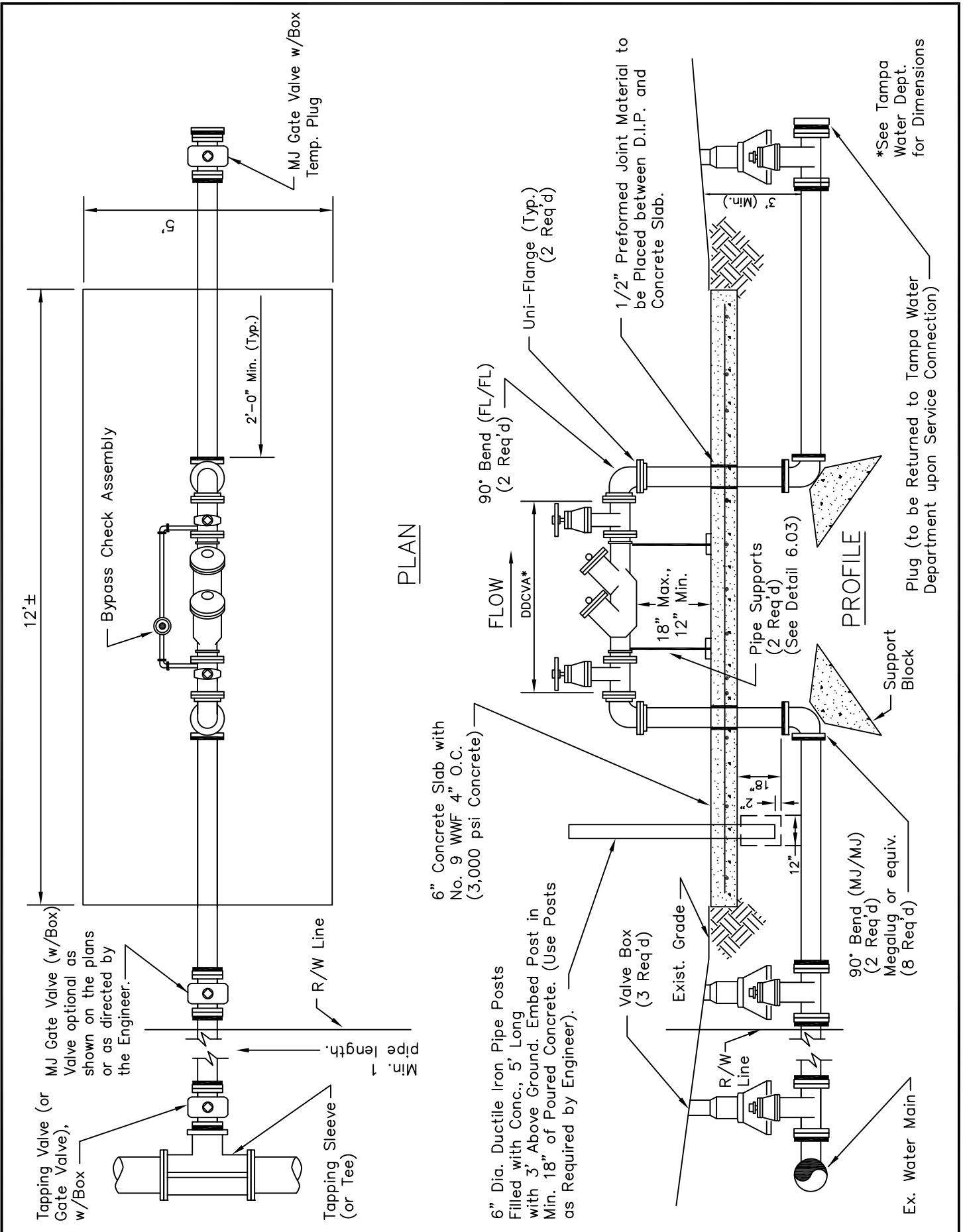

12' ±

Bypass Check Assembly

in

2'-0" Min. (Typ.)

MJ Gate Valve w/Box
Temp. Plug

Tapping Valve (or Gate Valve),
w/Box

MJ Gate Valve (w/Box) Valve optional as shown on the plans or as directed by the Engineer.

Tapping Sleeve (or Tee)

R/W Line

Min. pipe length.

PLAN

6" Concrete Slab with No. 9 WWF 4" O.C. (3,000 psi Concrete)

6" Dia. Ductile Iron Pipe Posts Filled with Conc., 5' Long with 3' Above Ground. Embed Post in Min. 18" of Poured Concrete. (Use Posts as Required by Engineer).

Valve Box (3 Req'd)

Exist. Grade

R/W Line

Ex. Water Main

90° Bend (FL/FL) (2 Req'd)

FLOW

DDCVA*

18" Max., 12" Min.

Pipe Supports (2 Req'd) (See Detail 6.03)

Uni-Flange (Typ.) (2 Req'd)

1/2" Preformed Joint Material to be Placed between D.I.P. and Concrete Slab.

Support Block

PROFILE

90° Bend (MJ/MJ) (2 Req'd) Megalug or equiv. (8 Req'd)

*See Tampa Water Dept. for Dimensions

Plug (to be Returned to Tampa Water Department upon Service Connection)

<p>TAMPA WATER DEPARTMENT</p>	<p>APPROVED Sept. 2011</p>	<p>REVISED</p> <p>____</p> <p>____</p>	<p>ABOVE GROUND DOUBLE DETECTOR CHECK VALVE ASSEMBLY</p>	<p>6.02</p>
-------------------------------	--------------------------------	--	--	-------------

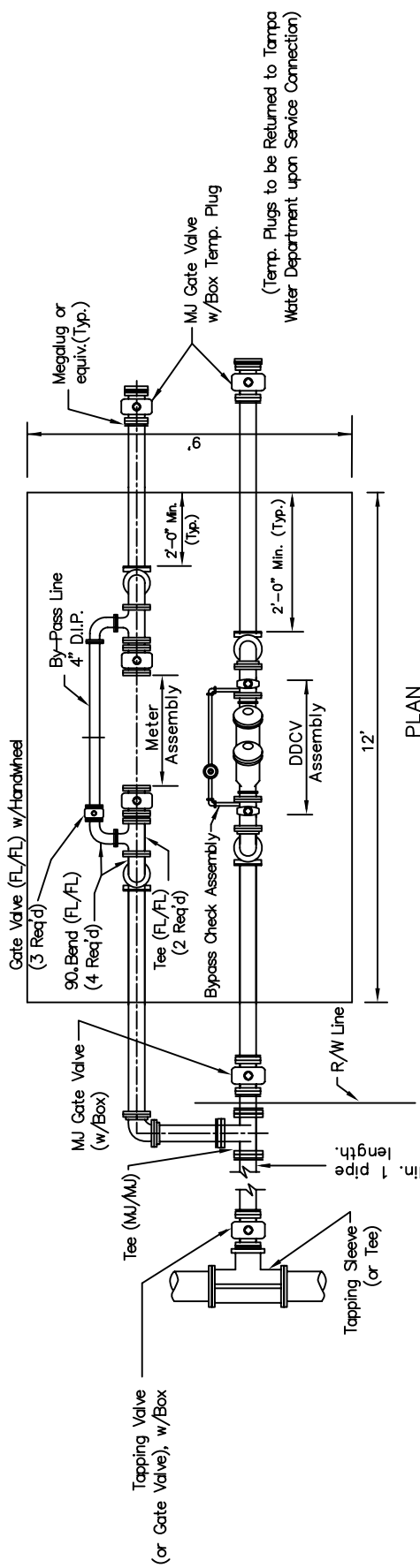

(Temp. Plugs to be Returned to Tampa Water Department upon Service Connection)

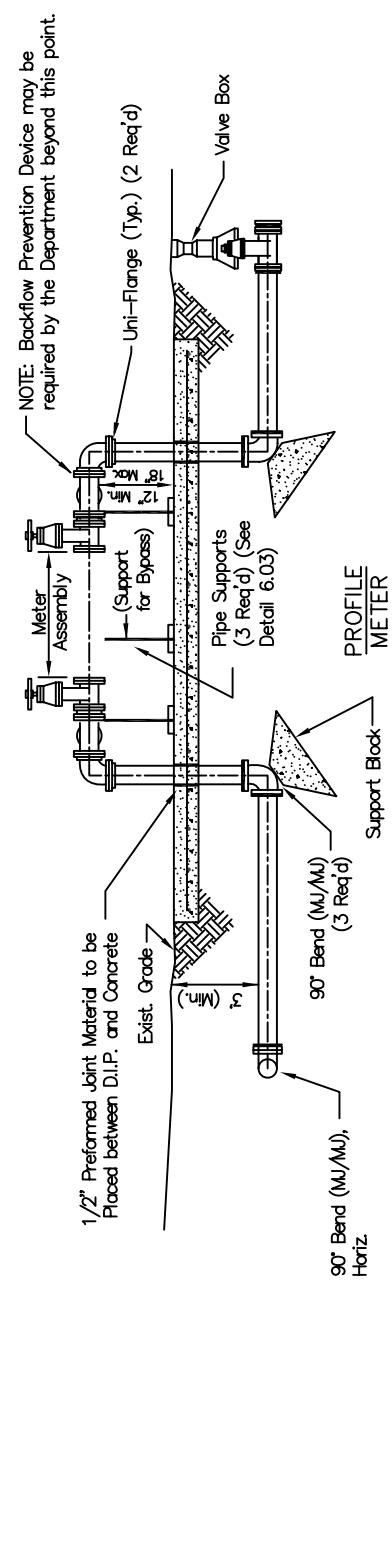
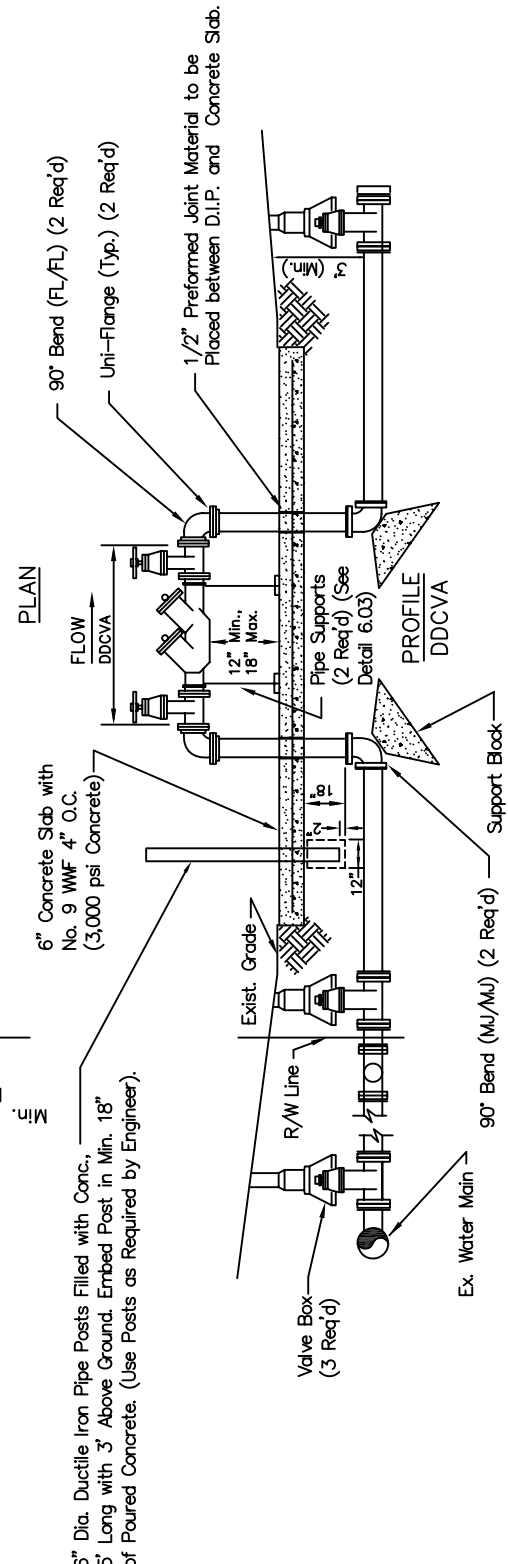

TAMPA WATER DEPARTMENT

APPROVED	REVISED
Sept. 2011	RNM 4/08
	JRD 9/2011

ABOVE GROUND DOUBLE DETECTOR CHECK VALVE ASSEMBLY AND TURBINE METER W/STRAINER

6.02B

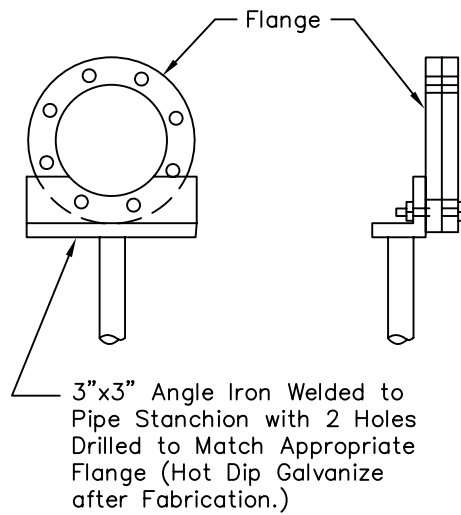
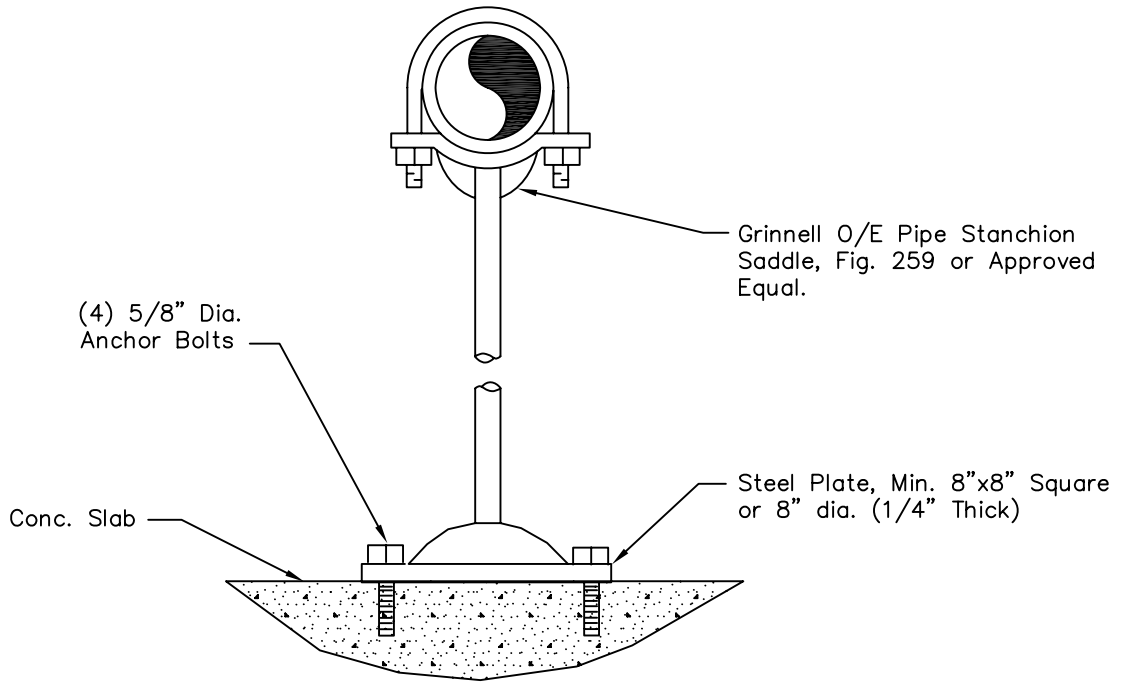

<p>TAMPA WATER DEPARTMENT</p>	<p>APPROVED Sept. 2011 _____</p>	<p>REVISED _____ _____ _____</p>	<p>PIPE SUPPORTS FOR ABOVE GROUND DDCVA</p>	<p>6.03</p>
---------------------------------------	--	--	---	-------------

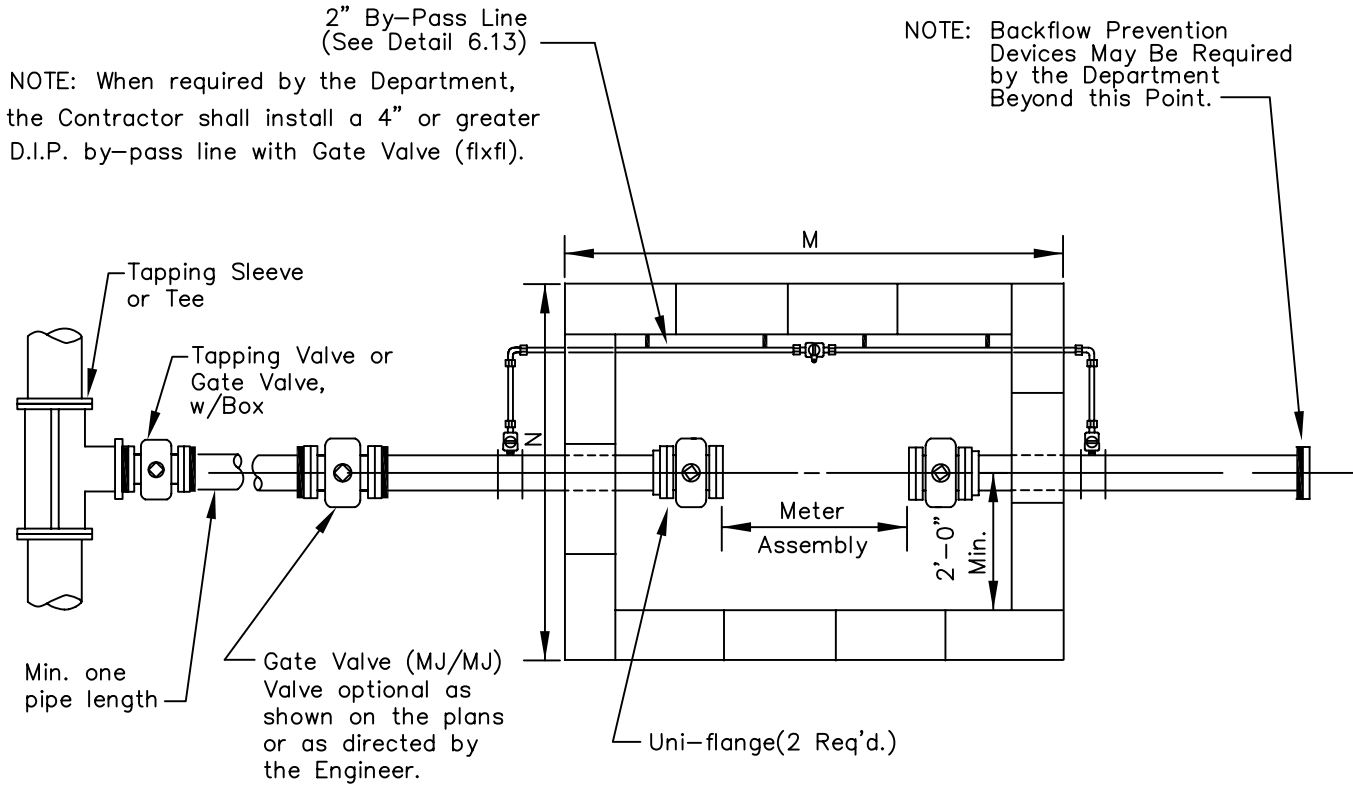

NOTE: See Details 6.07 & 6.08 for Vault Details and Dimensions.

PLAN

NOTE: CONSTRUCTION OF VAULT WITHOUT METER

1. Set uniface at minimum distance from wall and attach isolation valves.
2. Span distance between isolation valves with single piece of pipe.
3. To install meter, remove pipe between valves and attach meter to one valve. Pipe shall be cut to size to span the distance between meter and second valve.

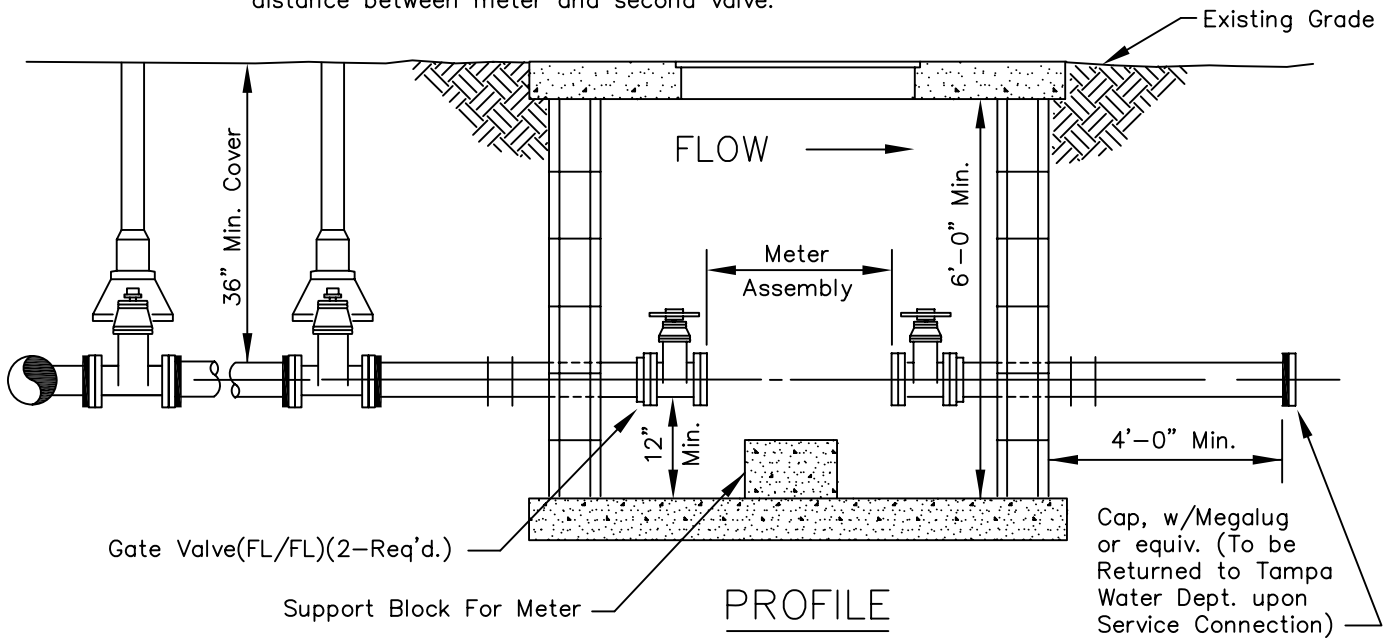

PROFILE

TAMPA WATER DEPARTMENT	APPROVED	REVISED	TURBINE METER IN VAULT	6.04
	Sept., 2011	JRD 4/09 JRD 9/2011		

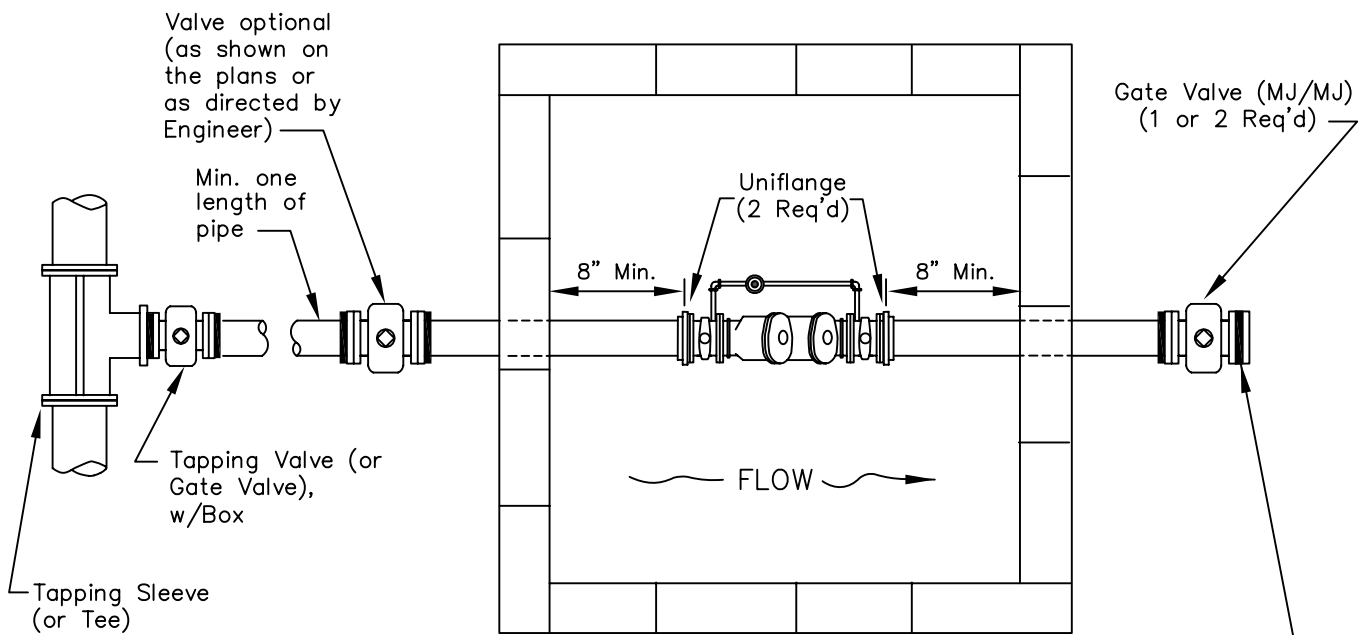

PLAN

NOTE: See Details 6.07 & 6.08 for Vault Construction Details and Dimensions.

Temp. plug (to be returned to Tampa Water Dept. upon connection to private fire line)

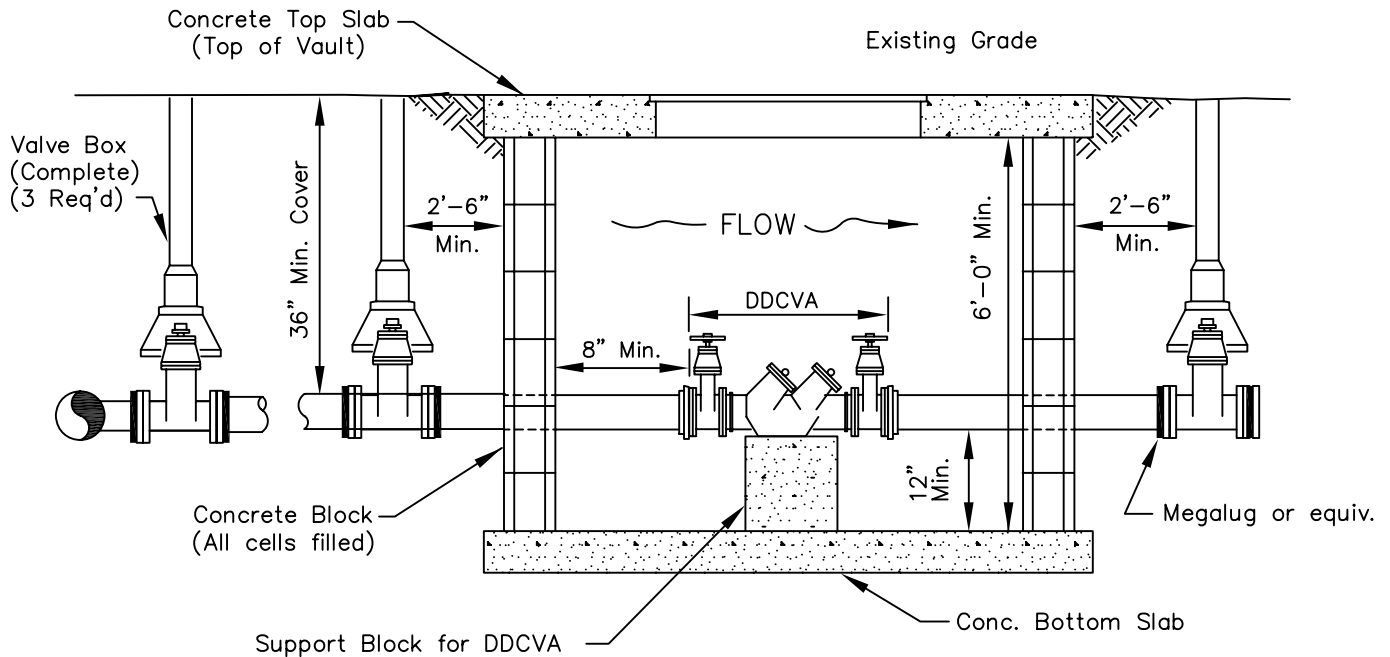

PROFILE

<p>TAMPA WATER DEPARTMENT</p>	<p>APPROVED Sept. 2011</p>	<p>REVISED</p> <p>____</p> <p>____</p>	<p>DOUBLE DETECTOR CHECK VALVE ASSEMBLY IN VAULT</p>	<p>6.05</p>
---------------------------------------	--------------------------------	--	--	-------------

NOTE: When required by the Department, the Contractor shall install a 4" or greater D.I.P. by-pass line.

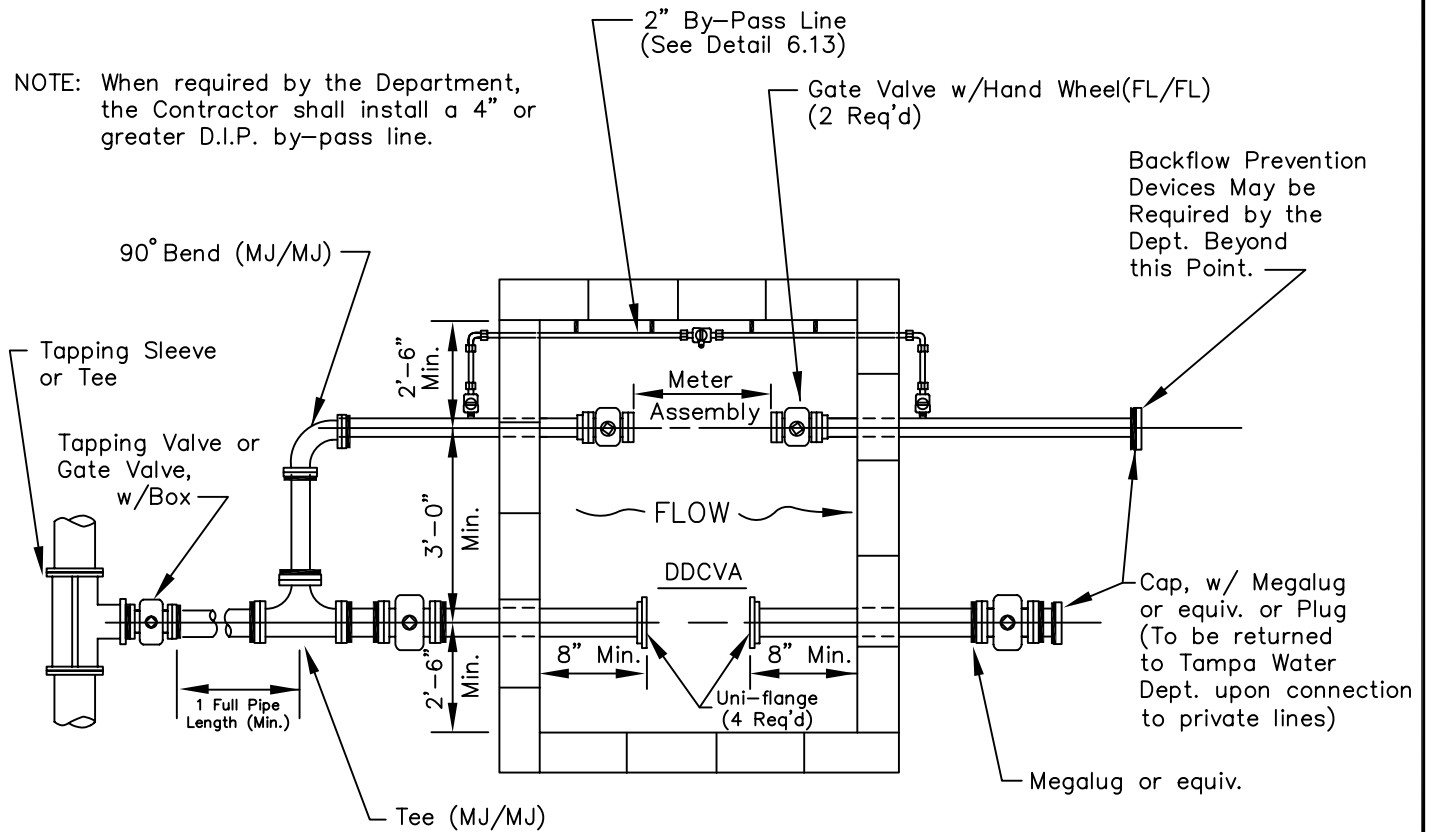

PLAN

NOTE: See Details 6.07 and 6.08 for Vault Details and Dimensions.

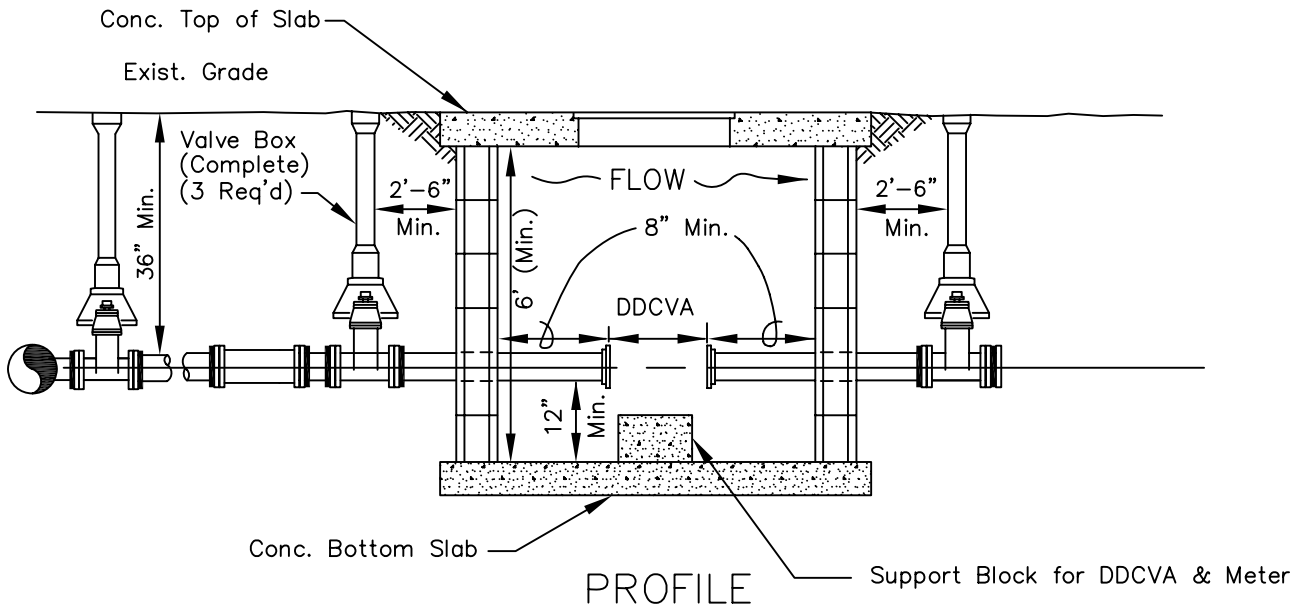

PROFILE

NOTE: VAULT CONSTRUCTION WITHOUT METER

1. Set unflange at minimum distance from wall and attach isolation valves.
2. Span between two isolation valves shall be a single piece of pipe through vault.
3. To install meter the pipe shall be cut to allow meter to be slipped into position and connected with 2 unflanges

TAMPA WATER DEPARTMENT	APPROVED	REVISED	DOUBLE DETECTOR CHECK VALVE ASSEMBLY W/3" & > DOMESTIC METER IN VAULT	6.06
	Sept. 2011	_____		
	_____	_____		

METER SIZE	Top & Bottom Slab Size		Vault Size	
	K	L	M	N
3" & 4" Turbine/ Compound Meter	6'-4"	6'-4"	6'-0"	6'-0"
3",4",6",8" Turbine Meter	8'-4"	5'-8"	8'-0"	5'-4"
4" Double Detector Check	6'-4"	6'-4"	6'-0"	6'-0"
6" Double Detector Check	8'-4"	5'-8"	8'-0"	5'-4"
8" Double Detector Check	9'-8"	8'-4"	9'-4"	8'-0"
10" Double Detector Check	11'-0"	8'-4"	10'-8"	8'-0"
4",6",8" DDCV & ≥3" Dom. Mtr.	8'-4"	9'-8"	8'-0"	9'-4"
10" DDCV & ≥3" Dom. Mtr.	8'-4"	11'-0"	8'-0"	10'-8"

NOTE: Vault and Slab sizes may vary as directed by the Engineer.

VAULT DIMENSIONS

All Concrete Poured into Cells Shall be a Min. of 3,000 p.s.i. Strength

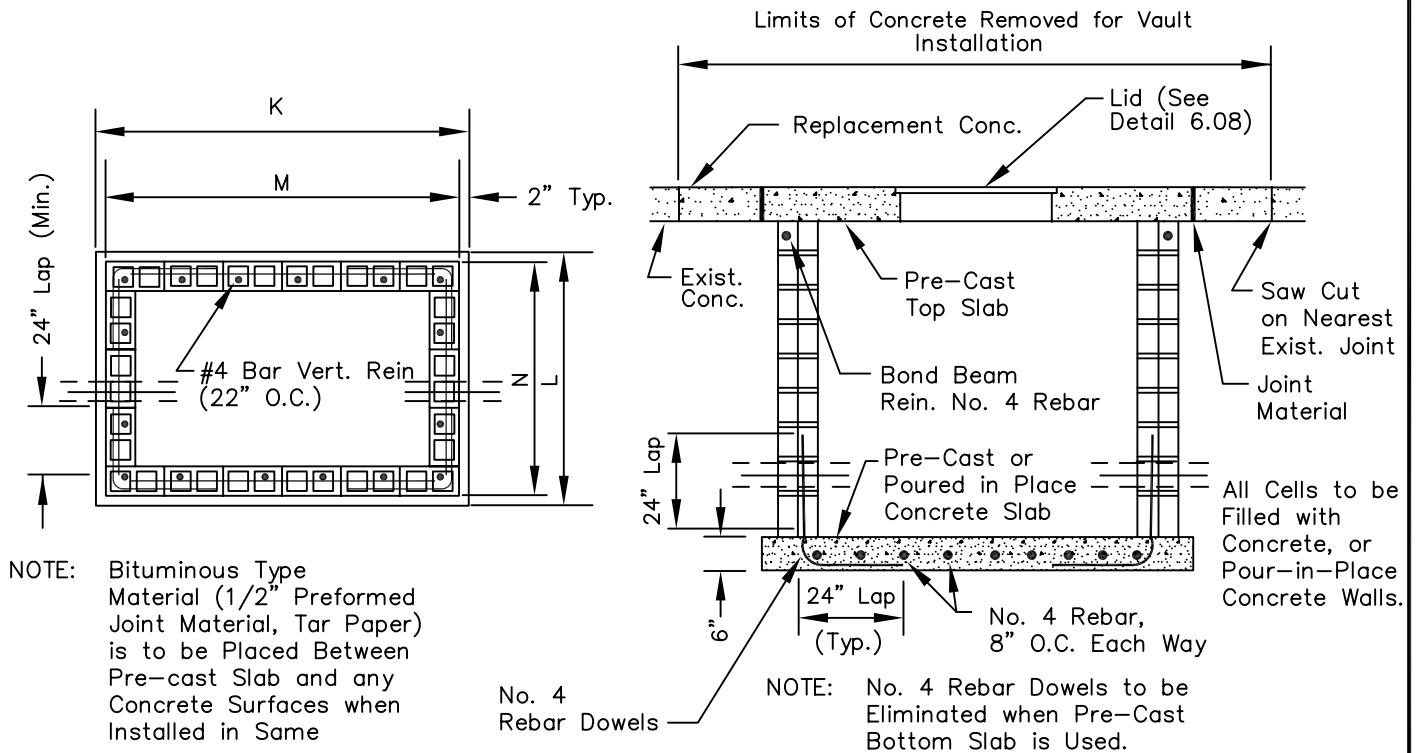

TAMPA WATER DEPARTMENT	APPROVED	REVISED	VAULT CONSTRUCTION DETAIL FOR DDCVA	6.07
	Sept. 2011	____		

SLAB SIZE			REBAR			
K	L	T	K		L	
			Size	Spacing	Size	Spacing
TOP SLAB						
6'-4"	6'-4"	6"	No. 6	7-1/2"	No. 6	7-1/2"
8'-4"	5'-8"	6"	No. 6	5-1/4"	No. 6	8-1/2"
9'-8"	8'-4"	8"	No. 6	5-1/8"	No. 6	6"
11'-0"	8'-4"	8"	No. 6	5-1/8"	No. 6	6"
BOTTOM SLAB						
6'-4"	6'-4"	6"	No. 4	8"	No. 4	8"
8'-4"	5'-8"	6"	No. 4	8"	No. 4	8"
9'-8"	8'-4"	6"	No. 4	8"	No. 4	8"
11'-0"	8'-4"	6"	No. 4	8"	No. 4	8"

Concrete- 4,500 psi 28 Day Strength
 Steel- 60 psi Yield Strength

NOTE: Slab size may vary as determined by the Engineer.

1/2" Penta Head Bolt-Downs

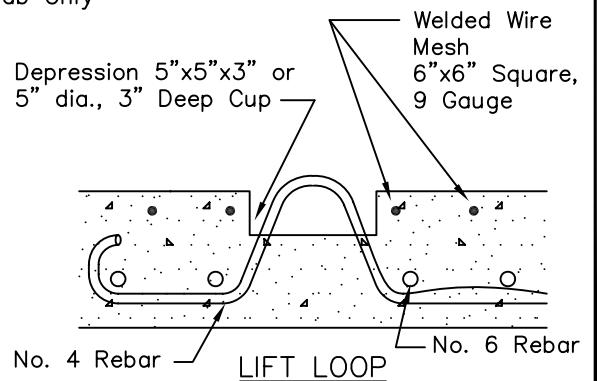
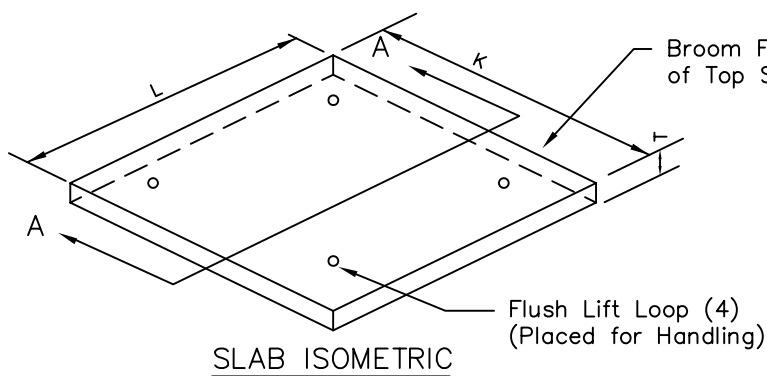
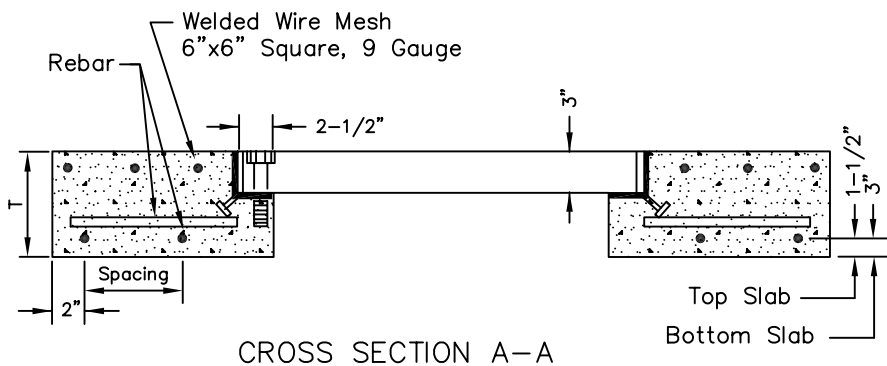
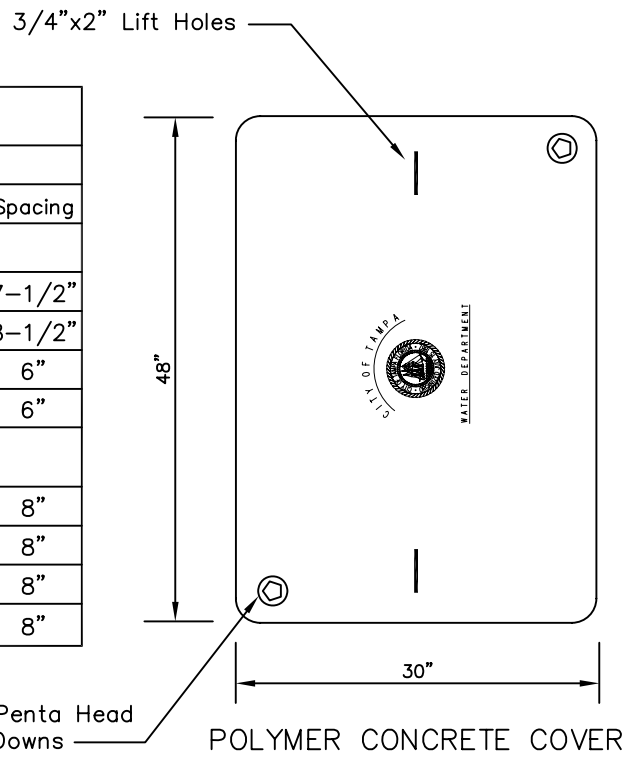

TAMPA
 WATER
 DEPARTMENT

APPROVED
 Sept. 2011

REVISED

VAULT
 CONCRETE SLAB
 DETAIL FOR DDCVA

6.08

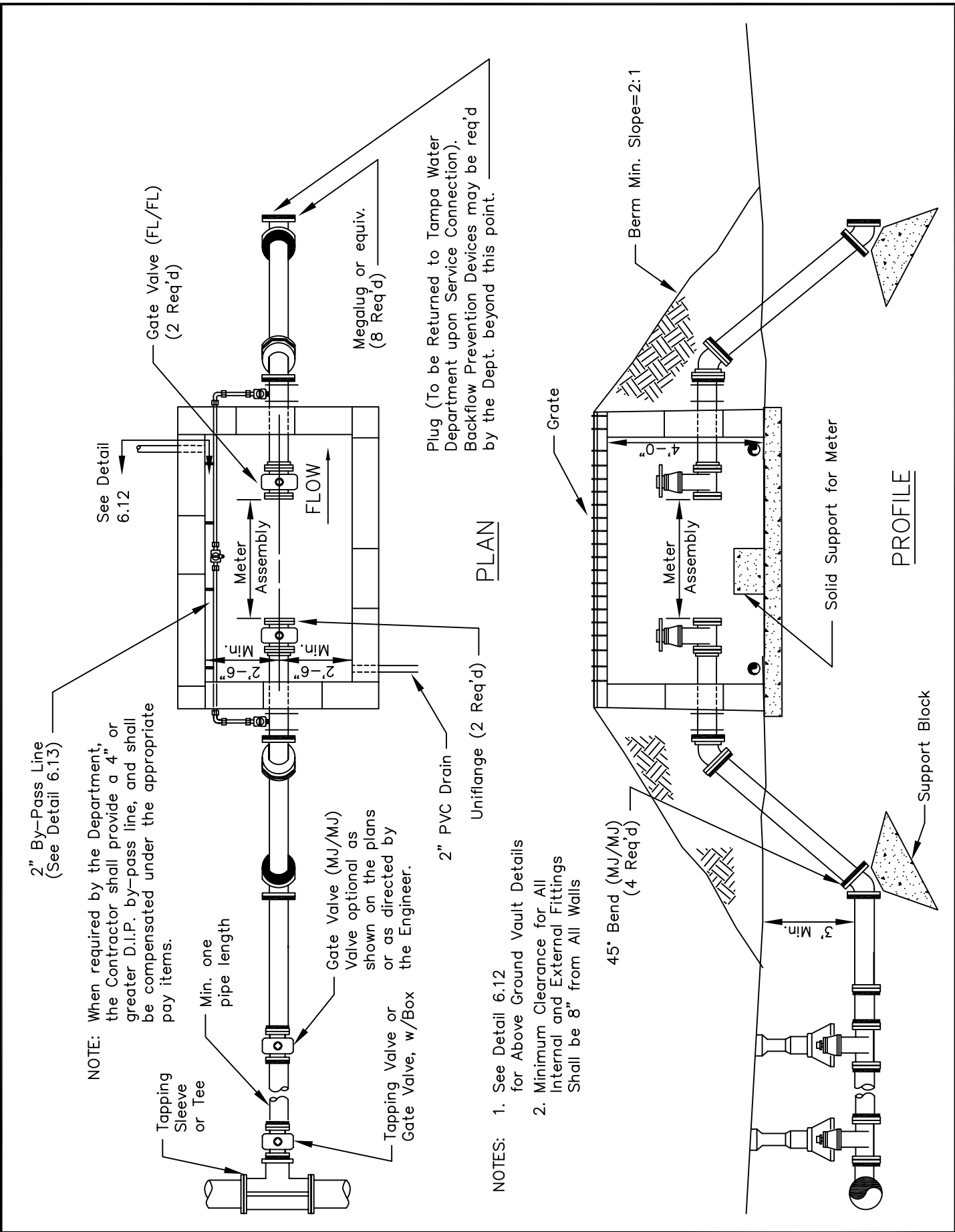

TAMPA WATER DEPARTMENT	APPROVED	REVISED	TURBINE METER W/STRAINERS IN ABOVE GROUND VAULT	6.09
	Sept. 2011	_____ _____ _____		

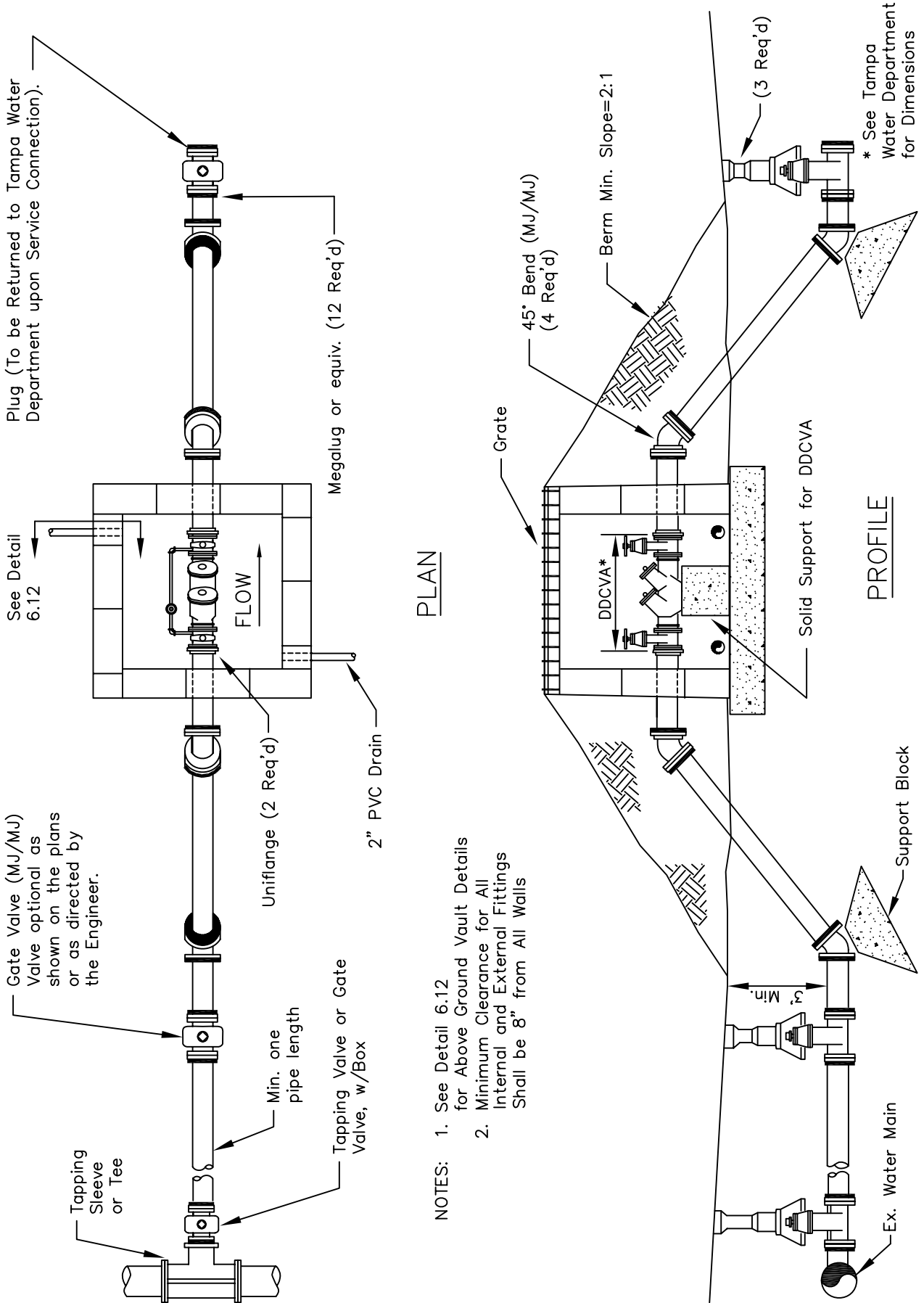

PLAN

PROFILE

- NOTES:
1. See Detail 6.12 for Above Ground Vault Details
 2. Minimum Clearance for All Internal and External Fittings Shall be 8" from All Walls

* See Tampa Water Department for Dimensions

TAMPA WATER DEPARTMENT

APPROVED
Sept. 2011

REVISED

DOUBLE DETECTOR CHECK VALVE ASSEMBLY IN ABOVE GROUND VAULT

6.10

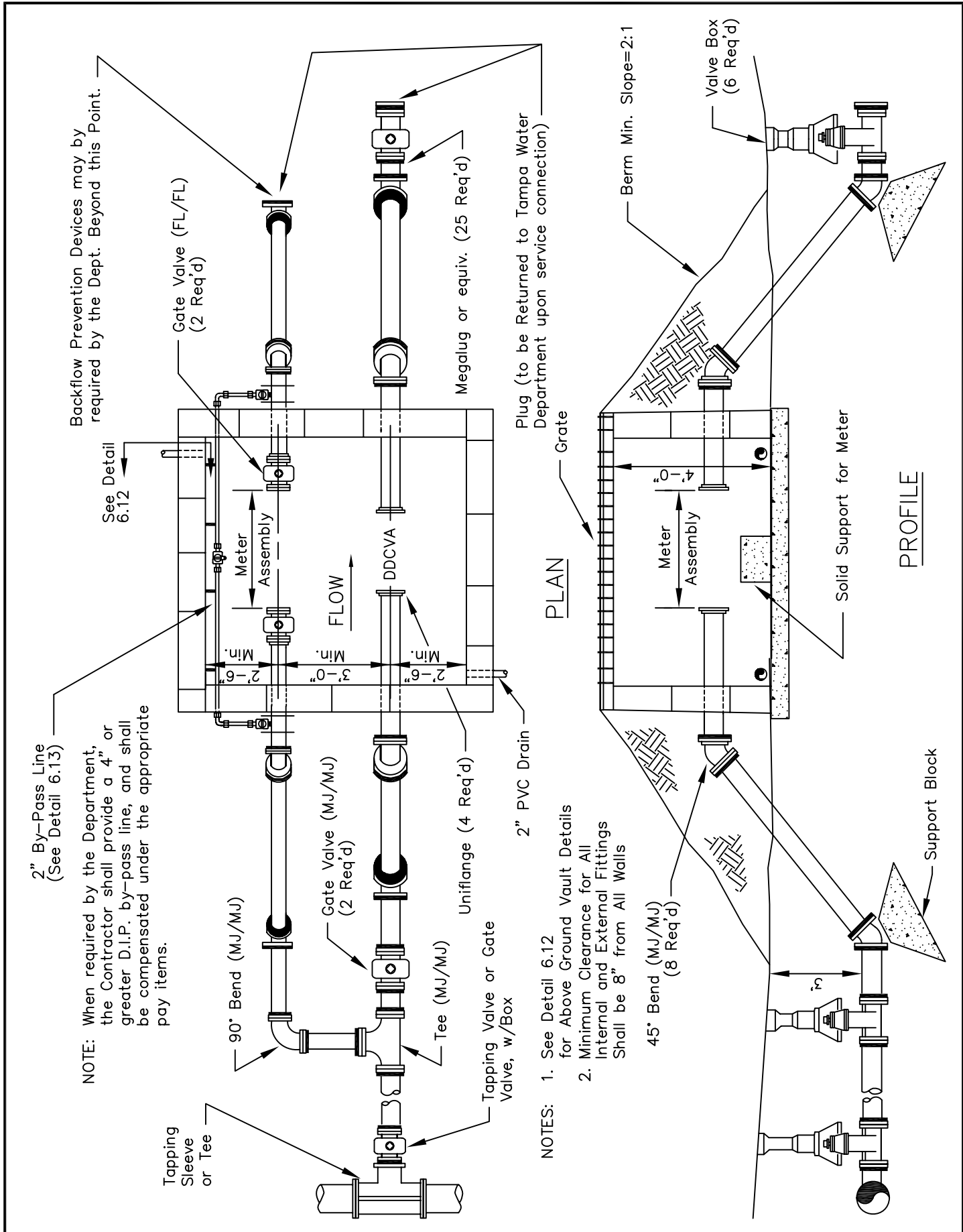

Backflow Prevention Devices may be required by the Dept. Beyond this Point.

2" By-Pass Line (See Detail 6.13)

NOTE: When required by the Department, the Contractor shall provide a 4" or greater D.I.P. by-pass line, and shall be compensated under the appropriate pay items.

See Detail 6.12

NOTES: 1. See Detail 6.12 for Above Ground Vault Details
 2. Minimum Clearance for All Internal and External Fittings Shall be 8" from All Walls

PLAN

PROFILE

TAMPA WATER DEPARTMENT

APPROVED
 Sept. 2011

REVISED

FIRE LINE SERVICE AND ≥ 3" DOMESTIC METER IN ABOVE GROUND VAULT

6.11

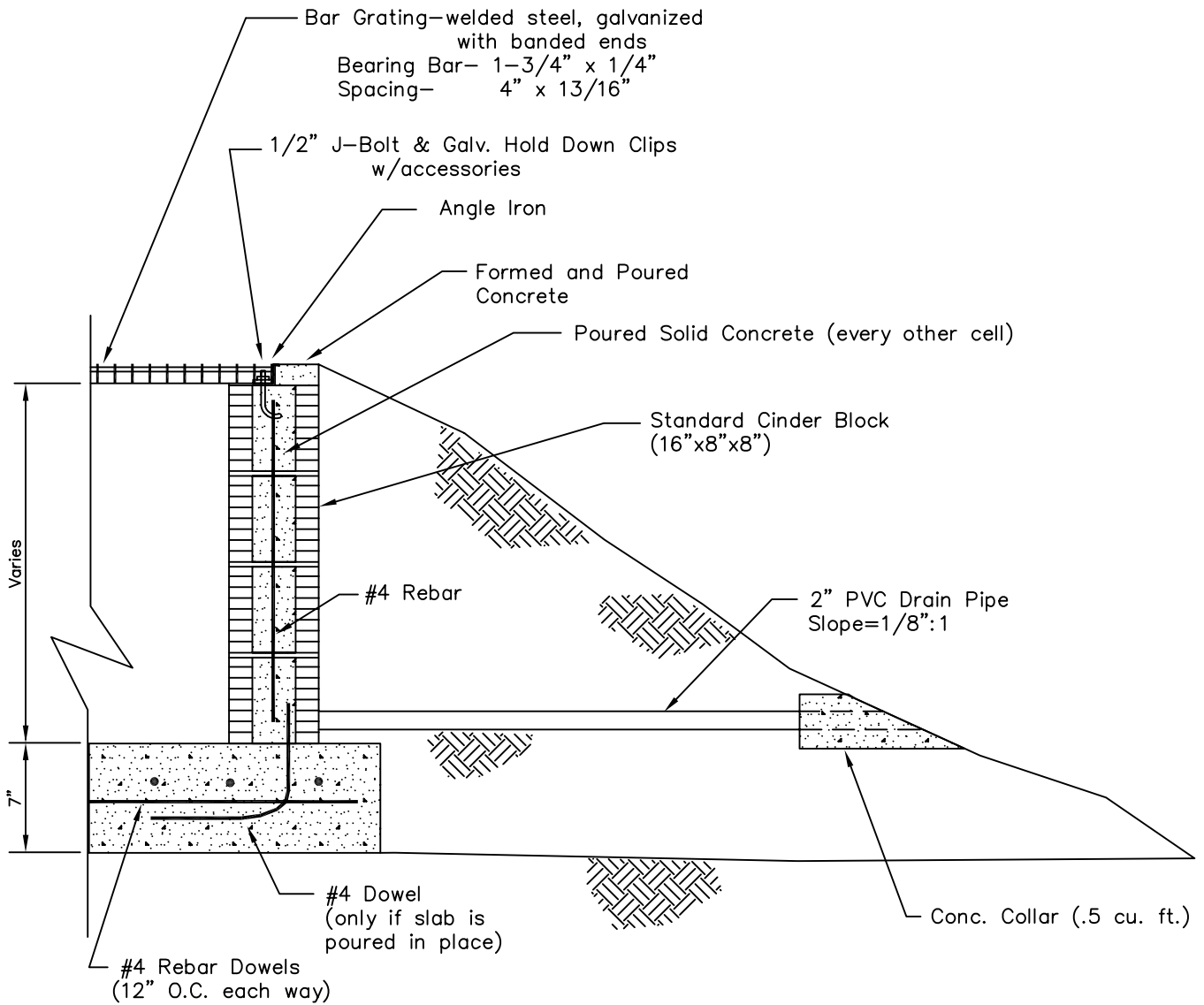

TYPICAL CROSS-SECTION DETAIL

NOTE:
 All Concrete Shall Have a Min. Compressive Strength of 3000 psi in 28 Days.

TAMPA WATER DEPARTMENT	APPROVED <u>Sept. 2011</u>	REVISED _____ _____ _____	ABOVE GROUND VAULT CROSS-SECTION	6.12
------------------------------	-------------------------------	------------------------------------	-------------------------------------	------

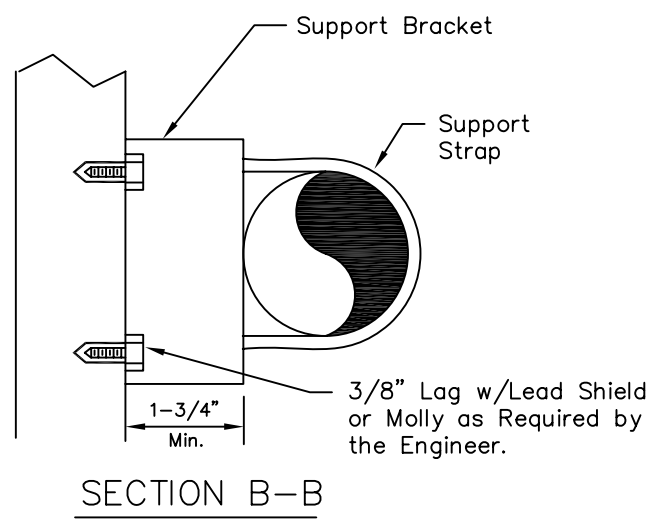
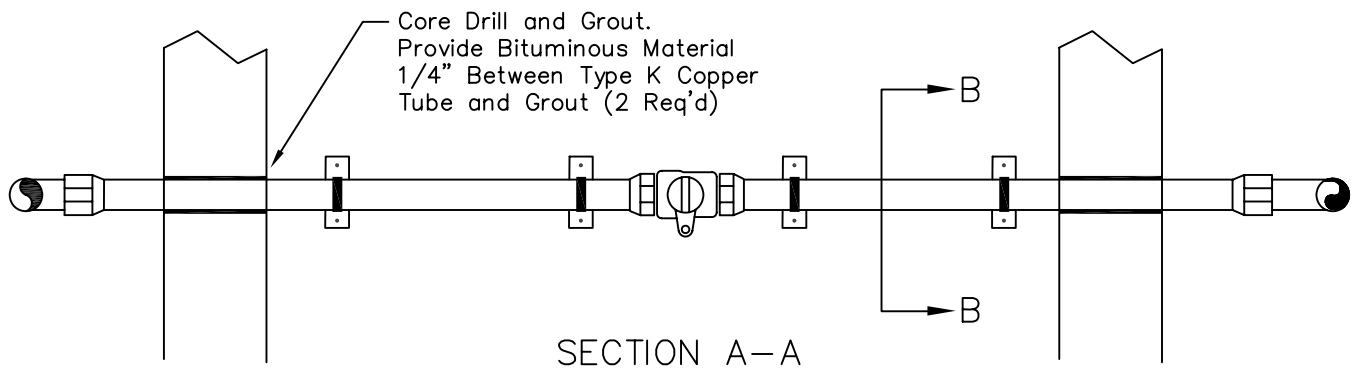
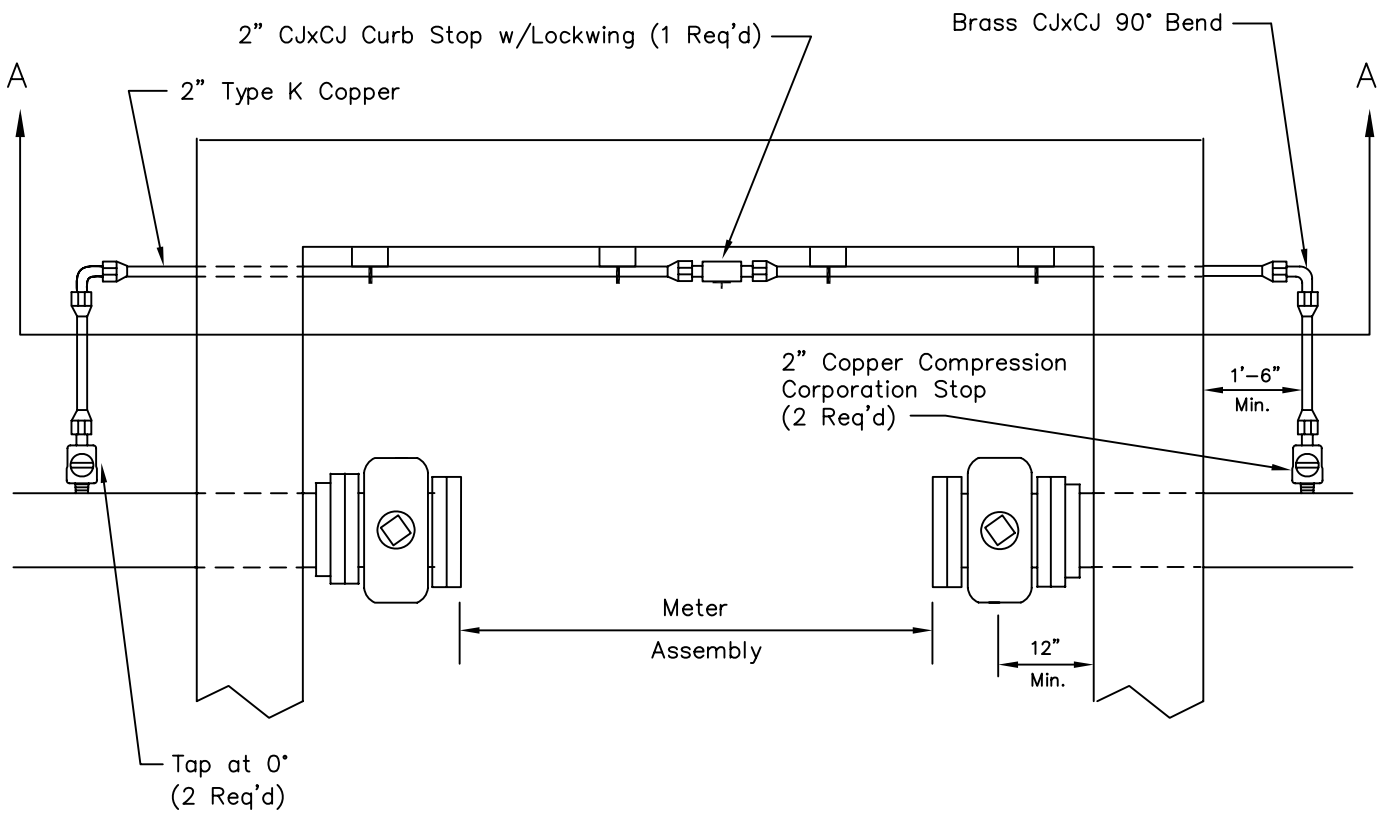

TAMPA WATER DEPARTMENT	APPROVED	REVISED	2" BY-PASS LINE	6.13
	Sept., 2011	_____		

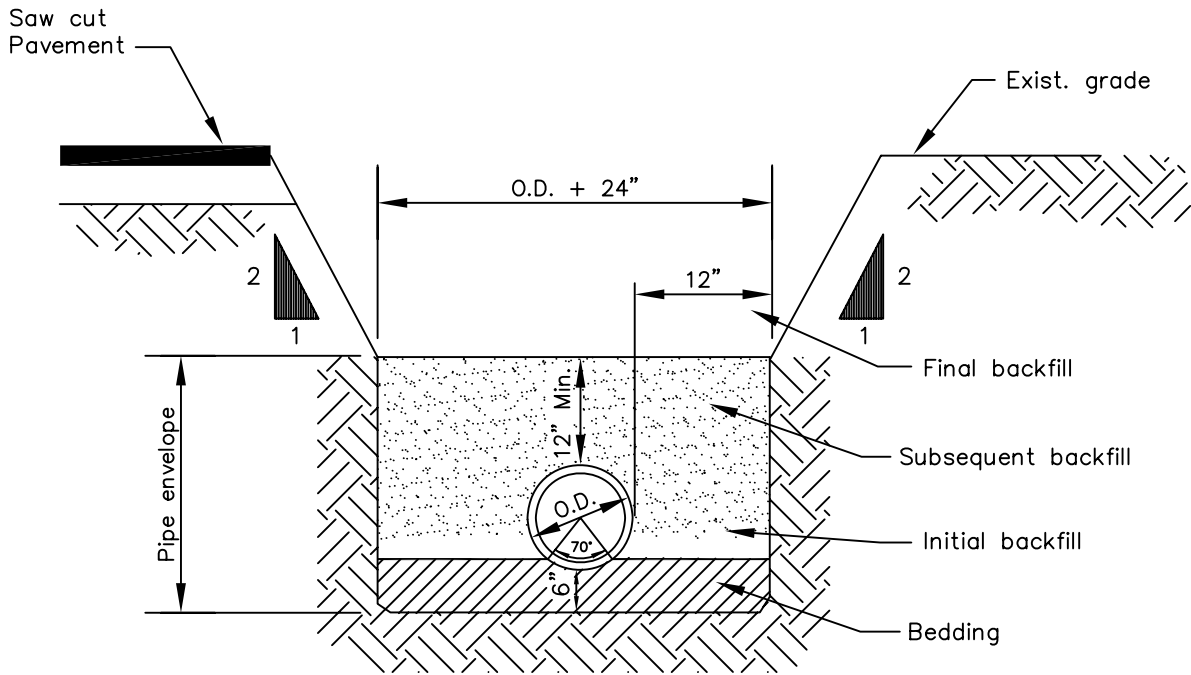

NOTES:

1. Pipe envelope bedding and backfill shall be compacted in 6" loose lifts.
2. Backfill above pipe envelope shall be compacted in 12" loose lifts maximum.
3. Backfill must be compacted to 98% of the maximum modified proctor density in paved and non-paved areas.

<p>TAMPA WATER DEPARTMENT</p>	<p>APPROVED Sept. 2011</p>	<p>REVISED _____ _____ _____</p>	<p>PIPE BEDDING AND TRENCH FOR PVC PIPE</p>	<p>7.01</p>
---------------------------------------	--------------------------------	--	---	-------------

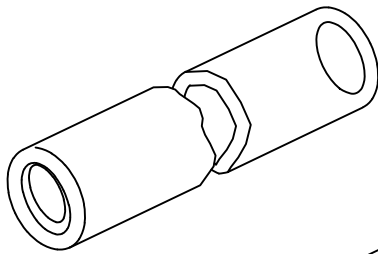
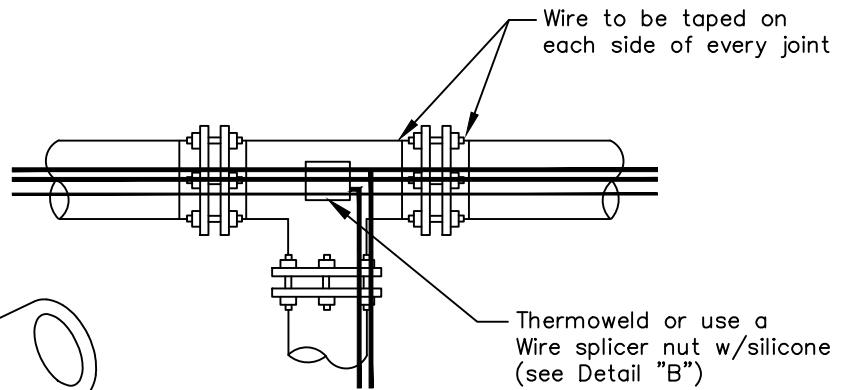
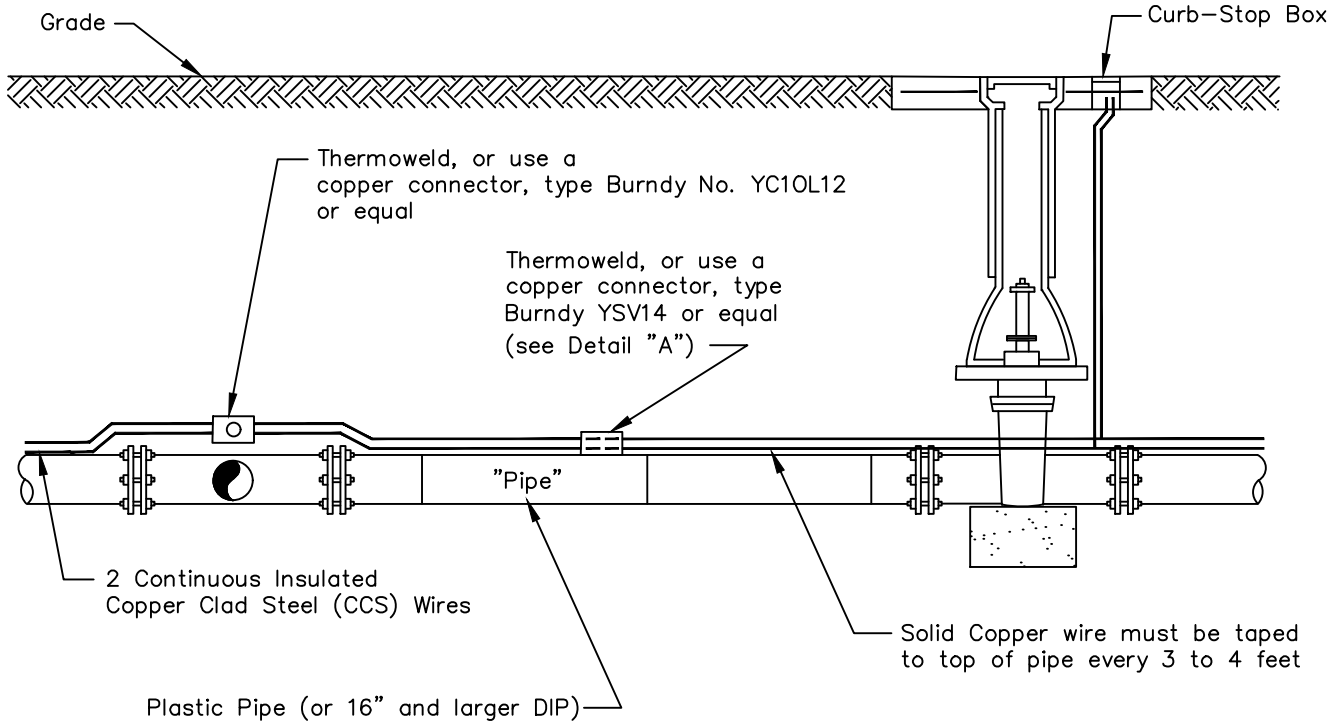

DETAIL "A"

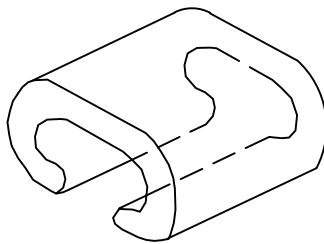

DETAIL "B"

NOTE:

All connections shall be sealed with a bituminous coating for corrosion protection

NTS

TAMPA WATER DEPARTMENT	APPROVED	REVISED		DOUBLE COPPER TRACER WIRE ON PIPE	7.02
	Sept. 2011	May 2019	RNM		
		Aug. 2017	RNM		

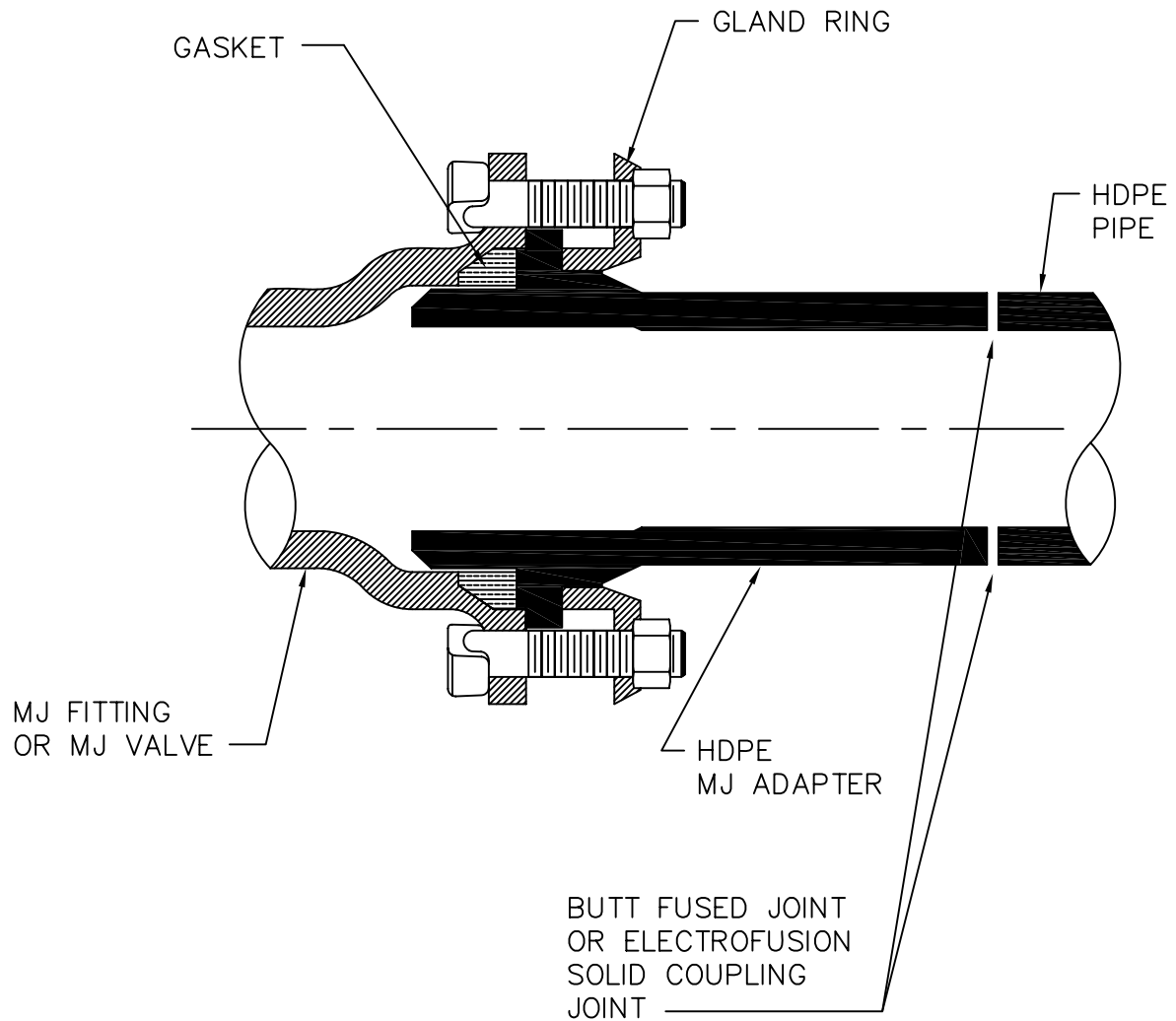

NOTES:

- (1) SCHEMATIC SHOWN FOR STANDARD MJ FITTINGS AND GATE VALVES.
- (2) BOLT LENGTH SIZED TO ACCOMODATE GLAND RING, MJ ADAPTOR AND MJ FITTING ON MJ VALVE.

<p>TAMPA WATER DEPARTMENT</p>	<p>APPROVED <u>Sept. 2011</u></p>	<p>REVISED _____ _____ _____</p>	<p>HDPE PIPE TO MJ FITTING TRANSITION</p>	<p>8.01</p>
---------------------------------------	---------------------------------------	--	---	-------------

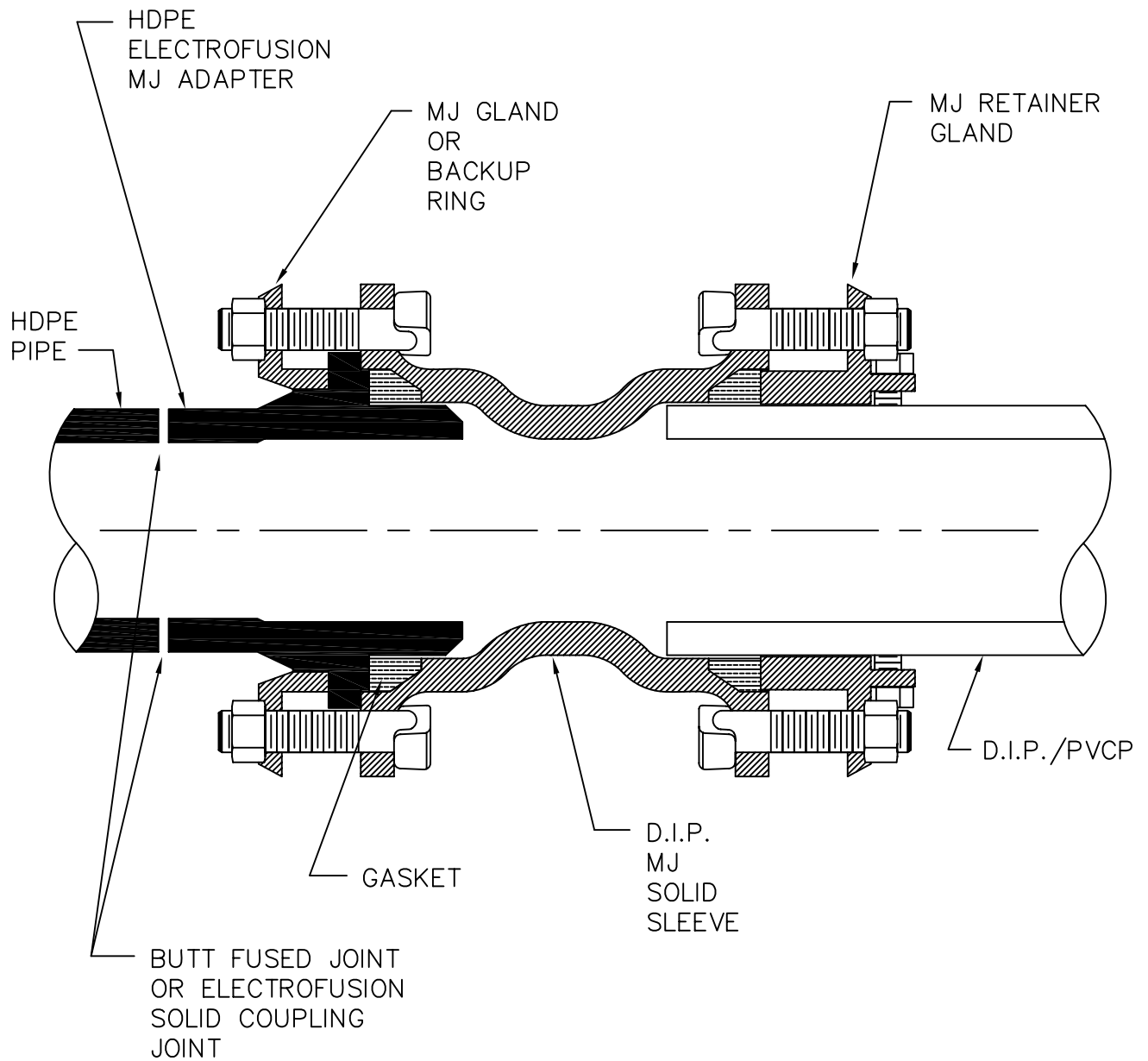

NOTES:

- (1) SCHEMATIC SHOWN FOR STANDARD MJ FITTINGS AND SLEEVES.
- (2) BOLT LENGTH SIZED TO ACCOMODATE GLAND RING, MJ ADAPTOR AND MJ FITTING ON MJ VALVE.

<p>TAMPA WATER DEPARTMENT</p>	<p>APPROVED Sept. 2011</p>	<p>REVISED _____ _____ _____</p>	<p>HDPE PIPE TO D.I.P./PVC SPIGOT-TO SPIGOT-CONNECTION</p>	<p>8.02</p>
---------------------------------------	--------------------------------	--	--	-------------

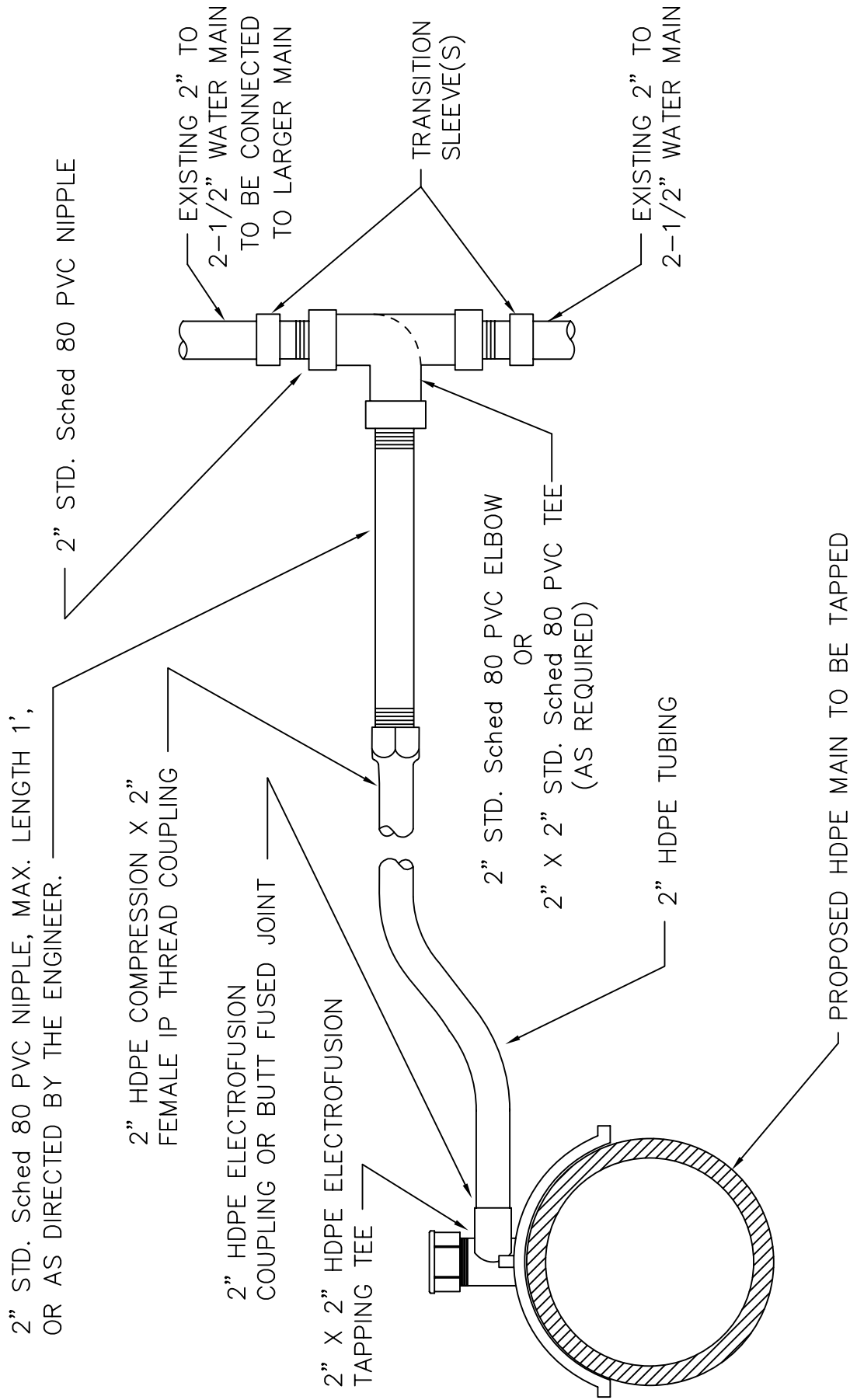

2" STD. Sched 80 PVC NIPPLE, MAX. LENGTH 1', OR AS DIRECTED BY THE ENGINEER.

2" HDPE COMPRESSION X 2" FEMALE IP THREAD COUPLING

2" HDPE ELECTROFUSION COUPLING OR BUTT FUSED JOINT

2" X 2" HDPE ELECTROFUSION TAPPING TEE

2" STD. Sched 80 PVC ELBOW OR 2" X 2" STD. Sched 80 PVC TEE (AS REQUIRED)

2" HDPE TUBING

PROPOSED HDPE MAIN TO BE TAPPED

NOTE: ALL CONNECTIONS NOT COVERED BY DETAIL 8.08 SHALL BE INSTALLED IN A MANNER ACCEPTABLE TO THE ENGINEER.

TAMPA WATER DEPARTMENT

APPROVED

Sept. 2011

REVISED

"TAPPED" CONNECTION FOR <4" WATER MAIN TO HDPE WATER MAIN

8.03

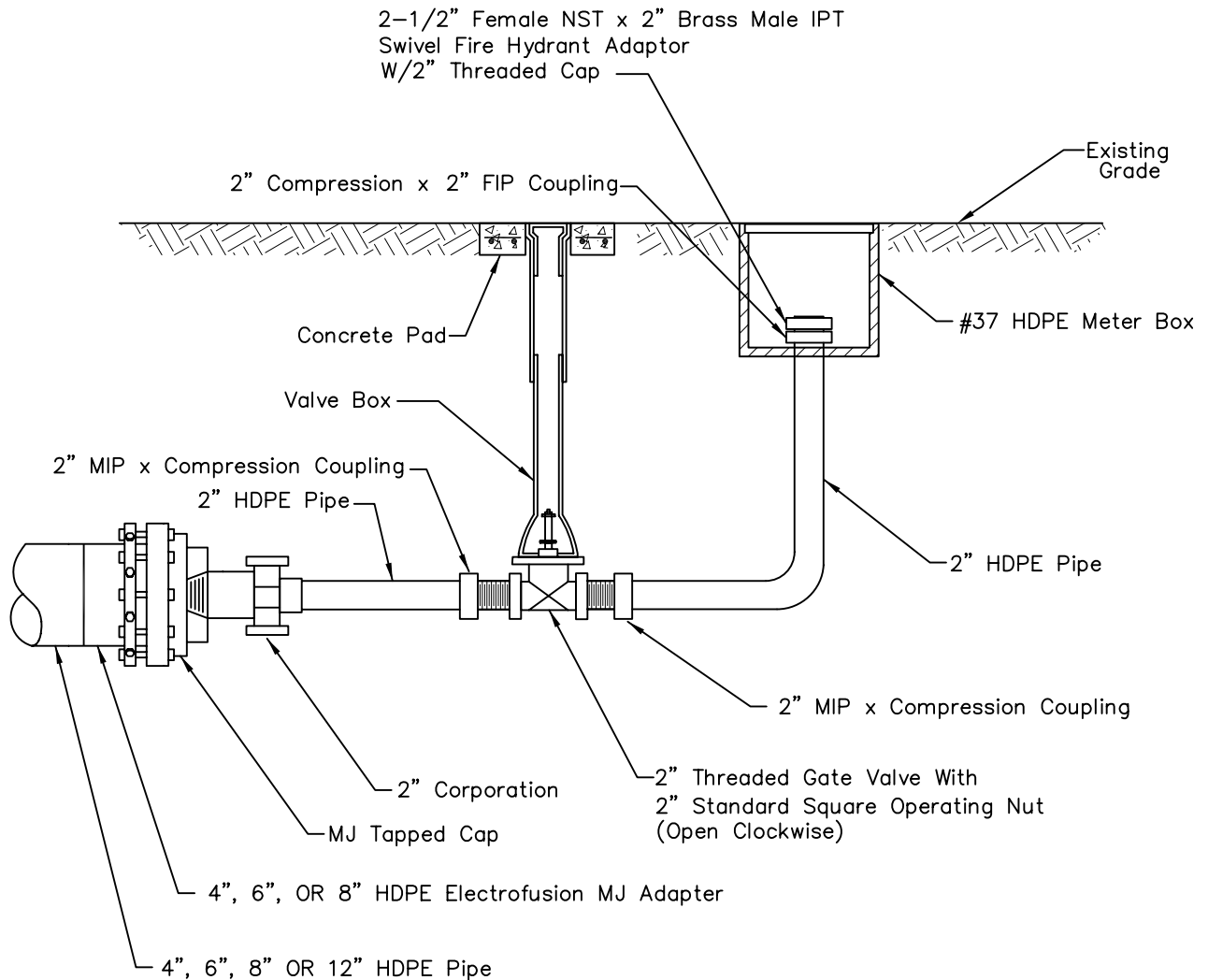

BLOW-OFF FOR ≥ 4 " MAINS

No galvanized pipe or fittings allowed
Schedule 80 PVC is allowed

N.T.S.

TAMPA WATER DEPARTMENT	APPROVED <u>Sept. 2011</u> _____	REVISED _____ _____ _____	BLOW-OFF VALVE ASSEMBLY ON ≥ 4 " HDPE PIPE	8.04
------------------------------	--	--	---	------

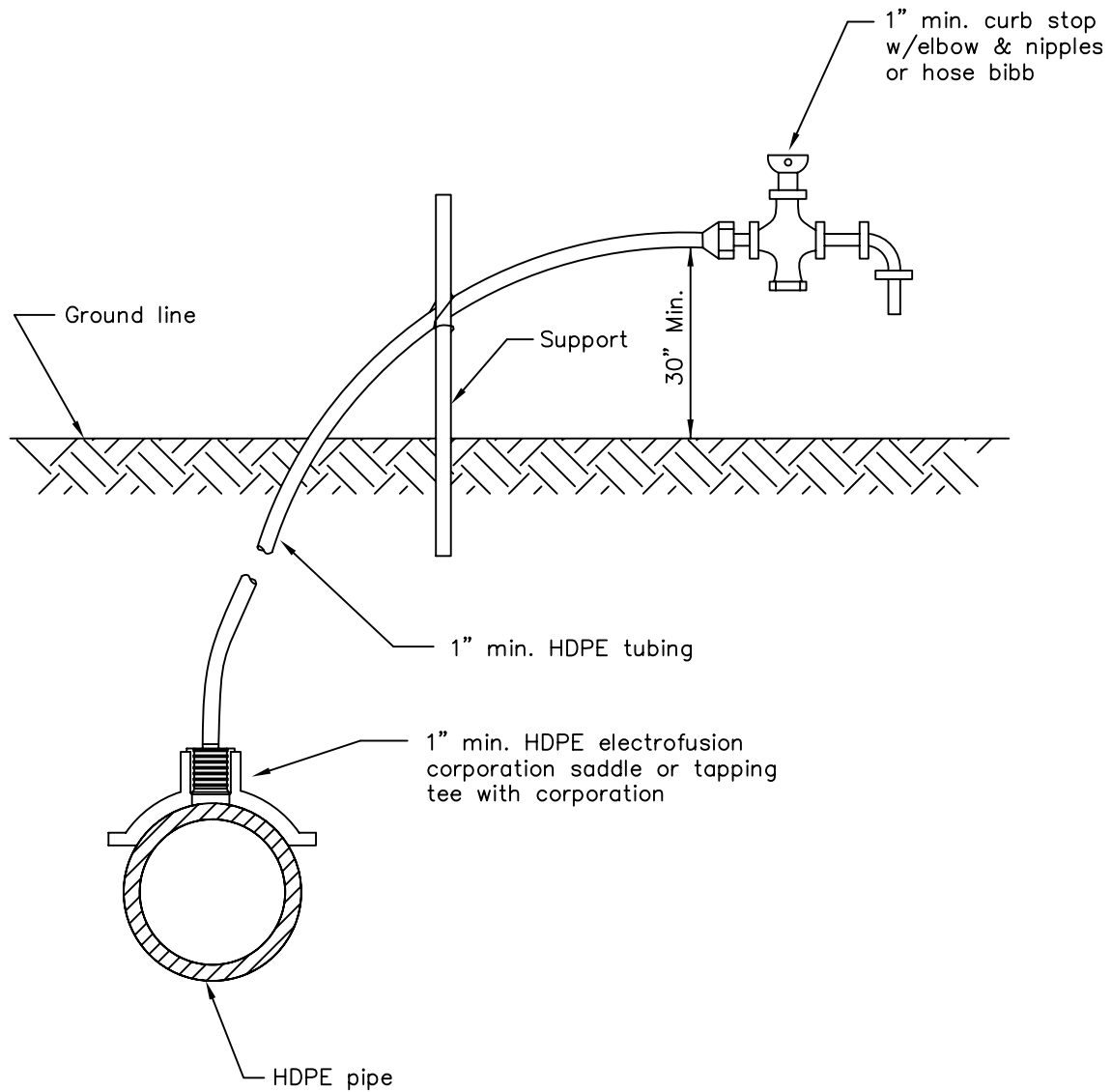

Notes:

1. Water outlet shall be held up off the ground so as not to interfere with the sampling process.
2. Corporation stop to be removed and plugged after operation.

<p>TAMPA WATER DEPARTMENT</p>	<p>APPROVED <u>Sept. 2011</u> _____</p>	<p>REVISED _____ _____ _____</p>	<p>TEMPORARY SAMPLE TAP INSTALLATION W/HDPE PIPE</p>	<p>8.05</p>
---------------------------------------	---	--	--	-------------

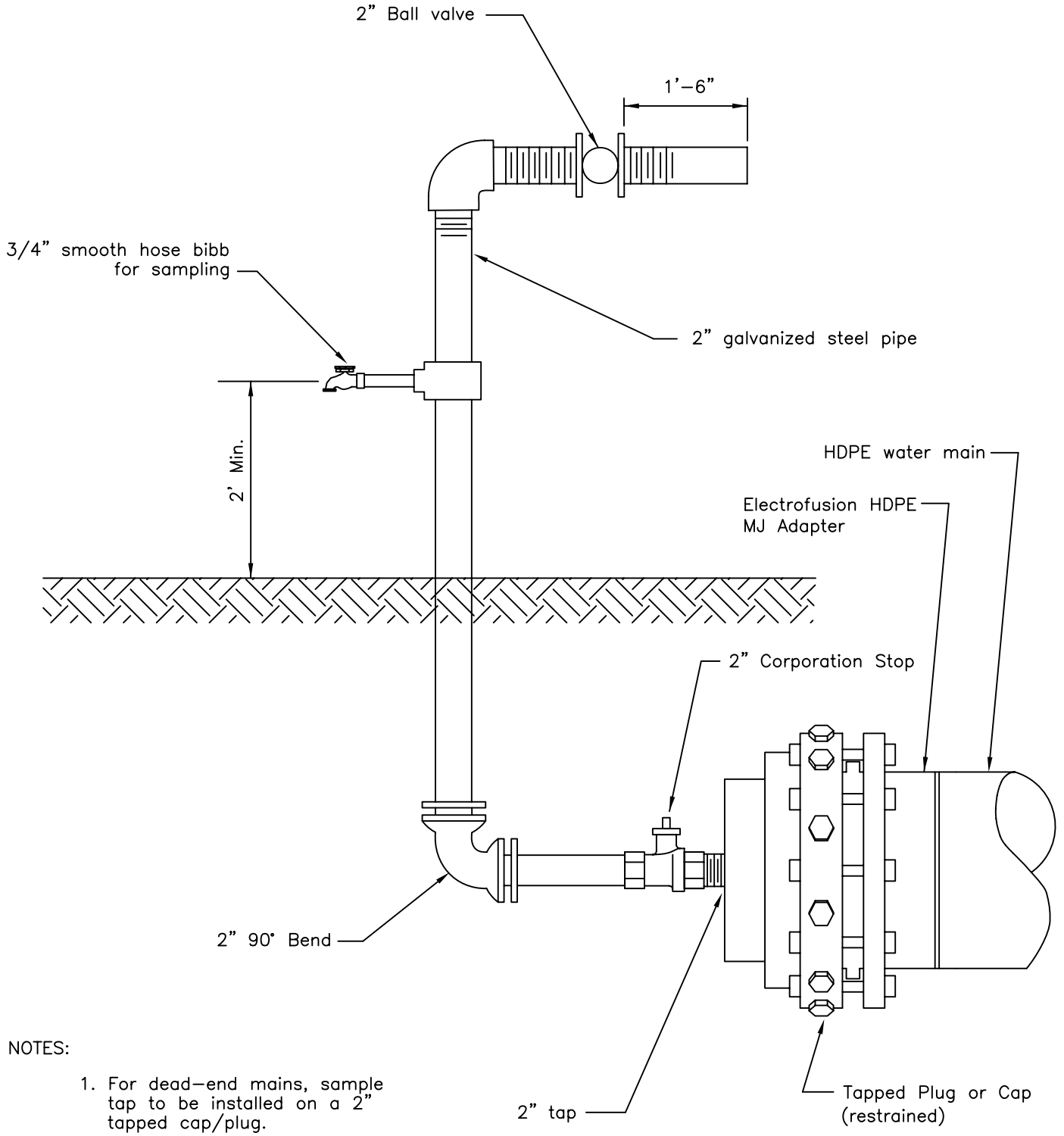

NOTES:

1. For dead-end mains, sample tap to be installed on a 2" tapped cap/plug.
2. Flushing/sampling arrangement to be removed after disinfection of main line.
3. After operation complete, install brass plug at corporation stop.

<p>TAMPA WATER DEPARTMENT</p>	<p>APPROVED <u>Sept. 2011</u></p>	<p>REVISED _____ _____</p>	<p>TEMPORARY SAMPLE TAP INSTALLATION FOR END OF LINE W/HDPE PIPE</p>	<p>8.06</p>
---------------------------------------	---------------------------------------	------------------------------------	--	-------------

WIRE MESH

(6 GAUGE 4" x 4" W.W.F.)

3000 PSI CONCRETE PAD
(See Notes)

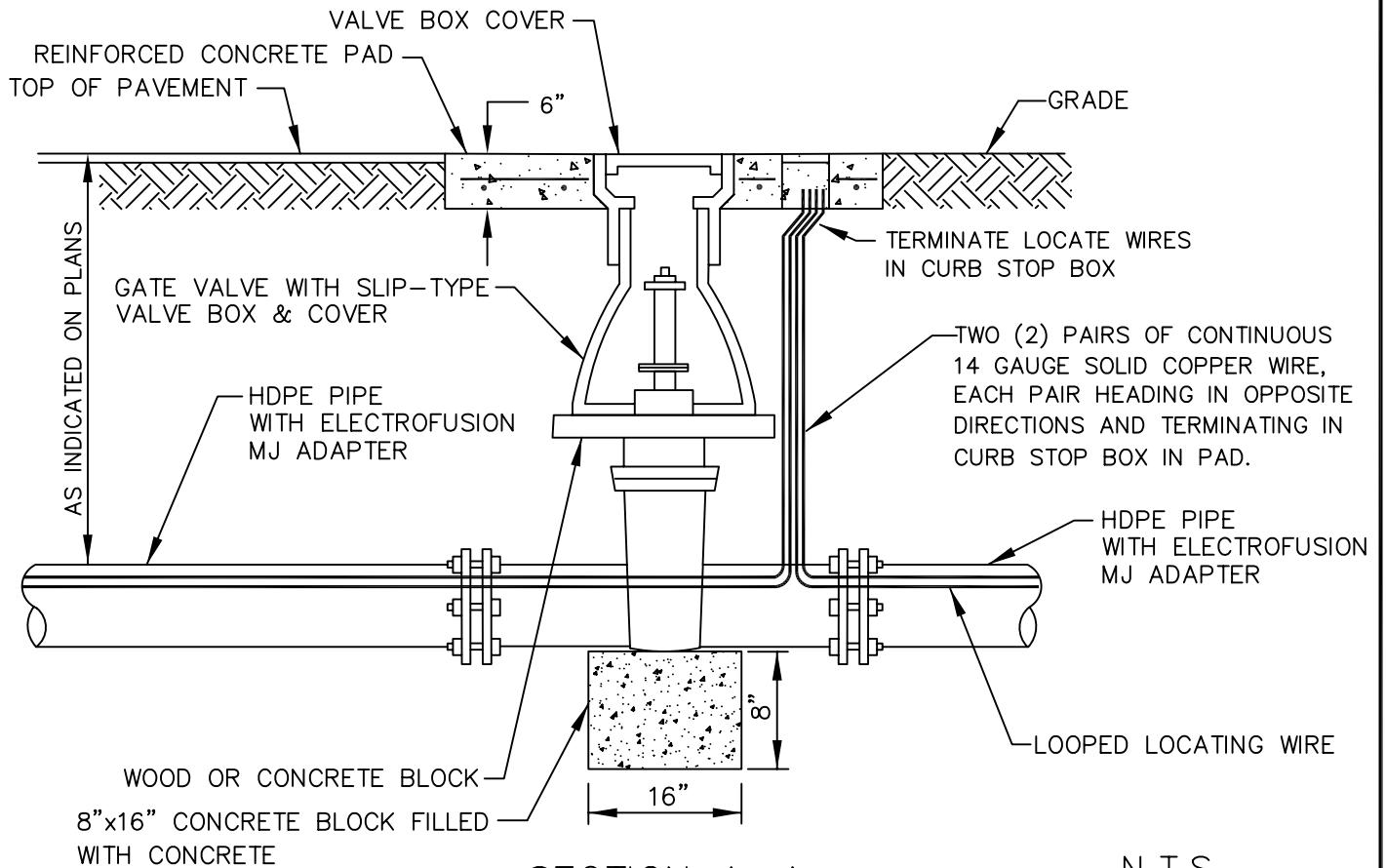
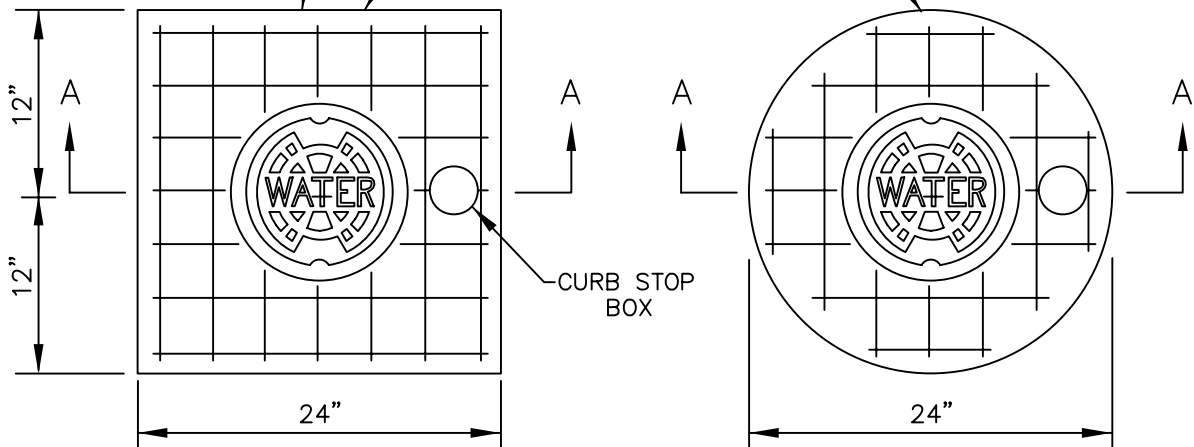

SECTION A-A

N.T.S.

Notes :

1. Circular or square concrete pad required for all valve box installations.
2. Cast iron valve boxes shall be firmly supported and centered and plumb over the operating nut of the valve. Valve box cover shall be flush with the surface of finished pavement or grade or at such other level as may be directed by the Department.
3. "Blue" Water Valve locate markers required for all valve installations.

TAMPA WATER DEPARTMENT	APPROVED	REVISED	VALVE SETTING W/HDPE PIPE	8.07
	Sept. 2011	____		

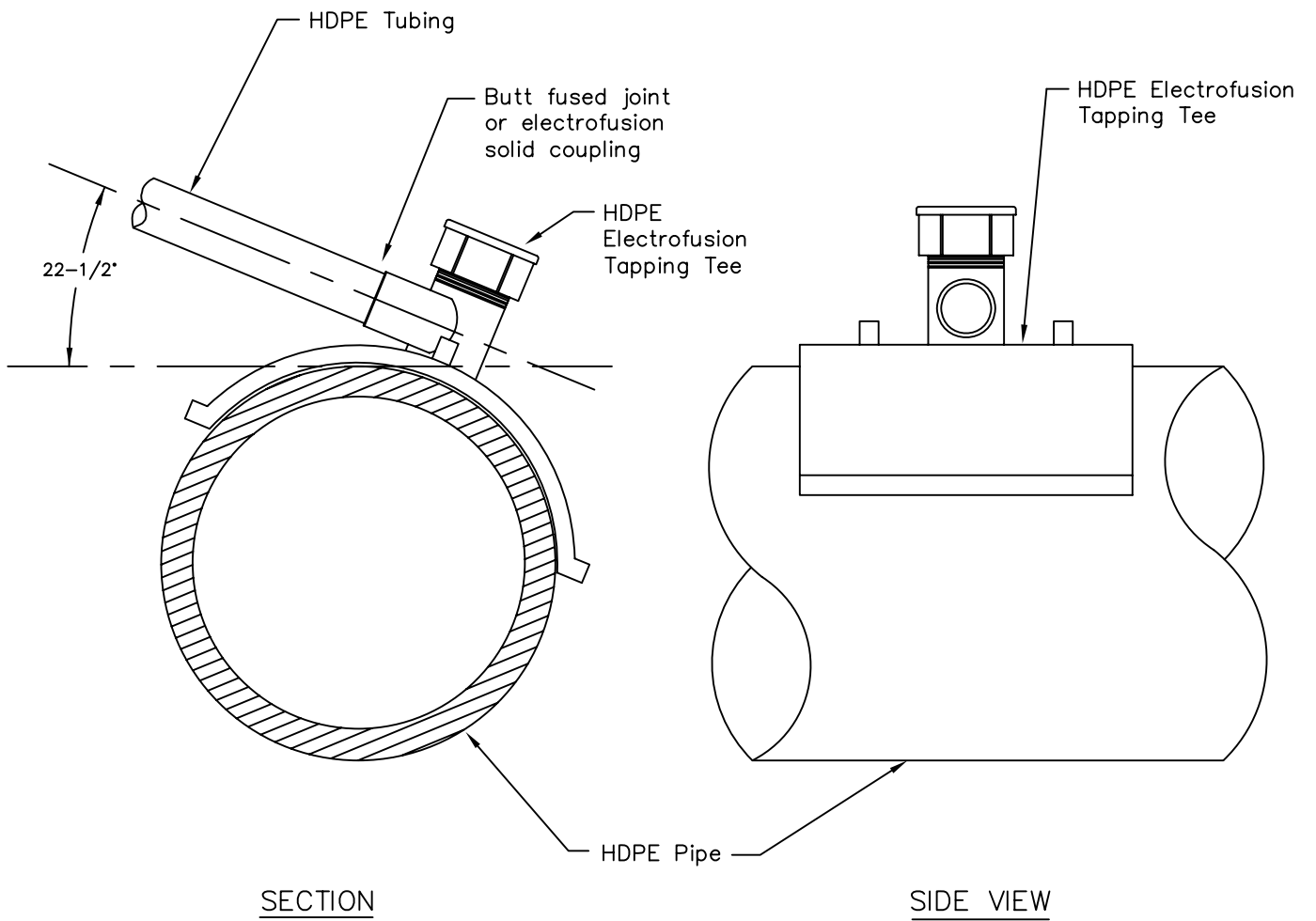

TAMPA
WATER
DEPARTMENT

APPROVED
Sept. 2011

REVISED

TAPPING DETAIL FOR
1" & 2"
SERVICE W/HDPE PIPE

8.08

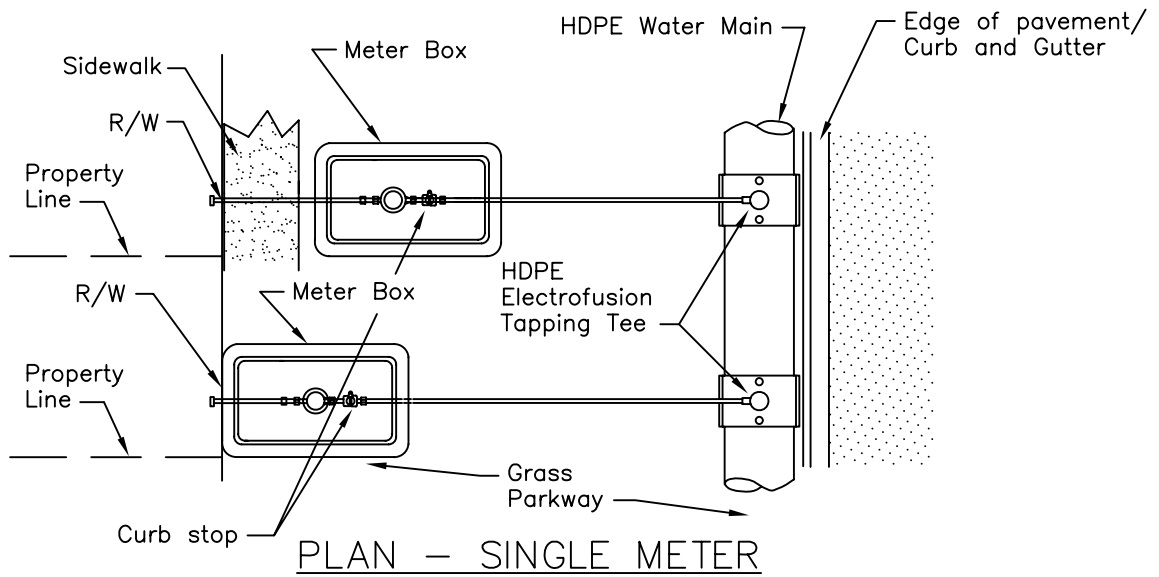

PLAN - SINGLE METER

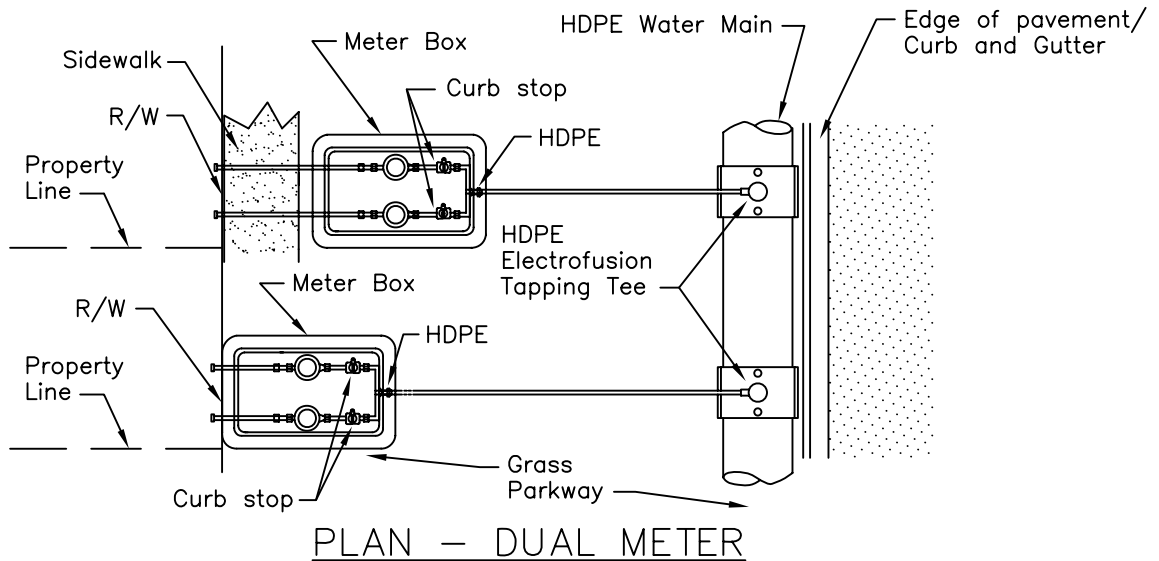

PLAN - DUAL METER

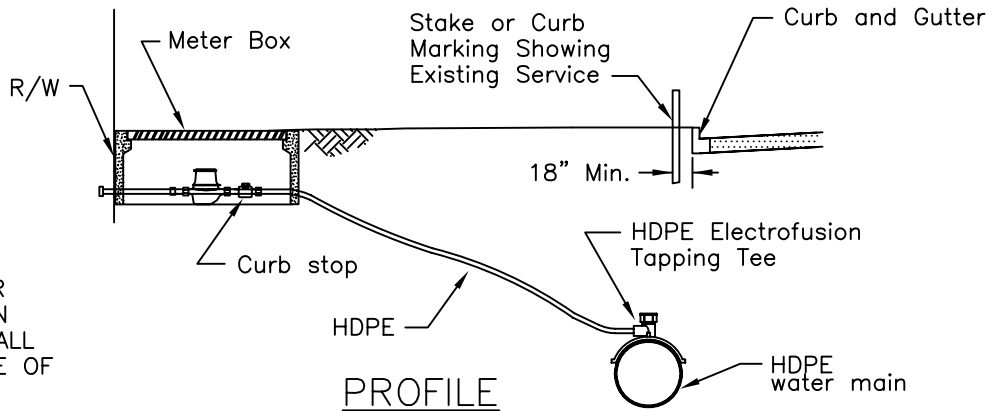

PROFILE

DO NOT INSTALL METER WITHIN SIDEWALK. WHEN SIDEWALK EXISTS, INSTALL METER ON STREET SIDE OF SIDEWALK OR WHERE DIRECTED BY ENGINEER.

SINGLE METER SIZE (inches)	SERVICE LINE SIZE (inches) (0-15')	DUAL METER SIZE (inches)	SERVICE LINE SIZE (inches) (0-15')
3/4	1	3/4	2
1	1	1	2
1-1/2	2	1-1/2	N/A
2	2	2	N/A

TAMPA WATER DEPARTMENT	APPROVED	REVISED	SINGLE & DUAL METERED SERVICE - SHORT SIDE 3/4", 1", 1-1/2" AND 2" W/HDPE PIPE	8.09
	Sept. 2011	_____		

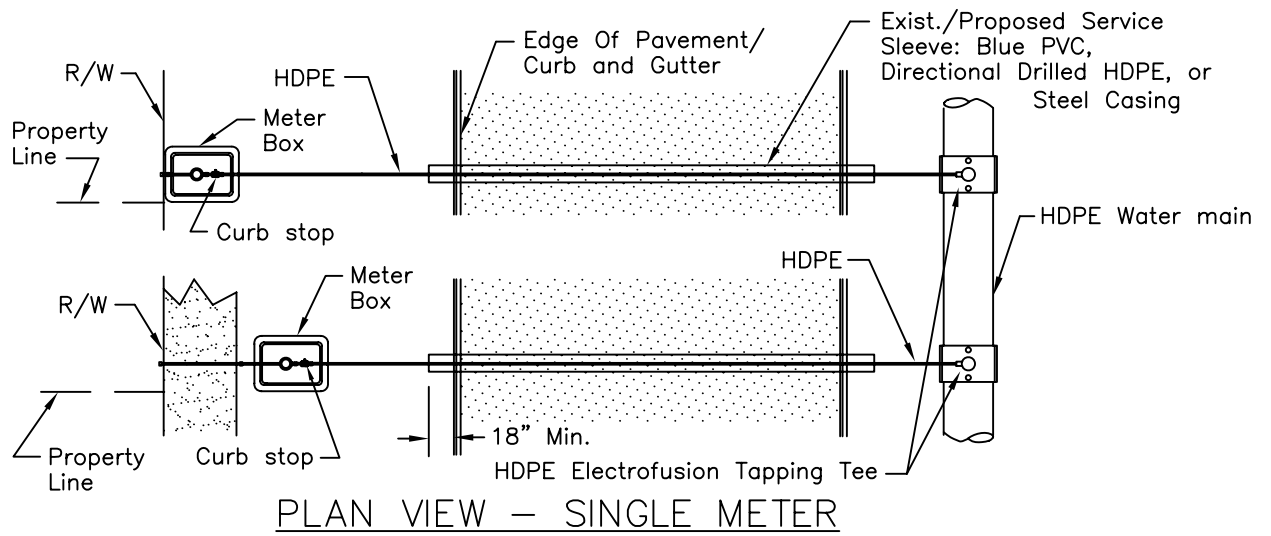

PLAN VIEW - SINGLE METER

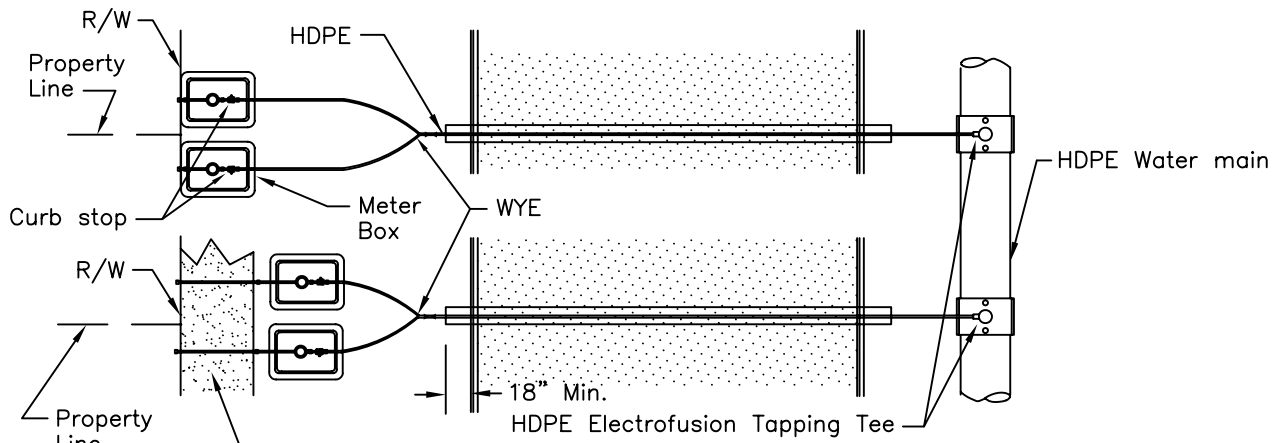

PLAN VIEW - DUAL METER

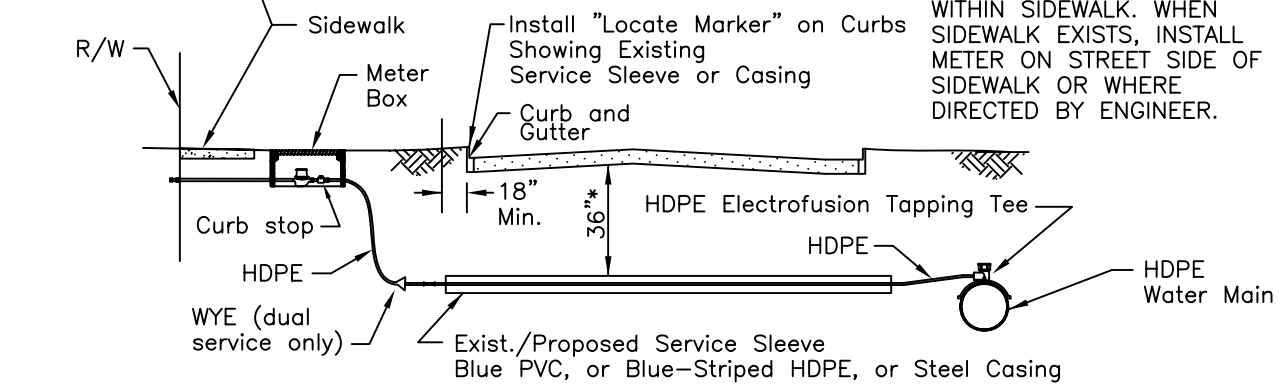

DO NOT INSTALL METER WITHIN SIDEWALK. WHEN SIDEWALK EXISTS, INSTALL METER ON STREET SIDE OF SIDEWALK OR WHERE DIRECTED BY ENGINEER.

CASING SPECIFICATION:

1. If pushed-SCH 40 steel pipe (min.)
2. If layed in open trench-SCH 40 steel pipe or SCH 80 PVC solvent weld pipe.

PROFILE VIEW (TYP.)

*Or greater, if required ROW Controlling Agency
 **Line size, applicable for 2" D.D.C.V.s

SINGLE METER SIZE (inches)	SERVICE LINE SIZE (inches)		CASING SIZE (inches)
	(>15'-80')	(>80'-150')	
3/4	1	2	2 / 4
1	2	2	4
1-1/2	2	2	4
2**	4" D.I.P.	4" D.I.P.	12

DUAL METER SIZE (inches)	SERVICE LINE SIZE (inches)		CASING SIZE (inches)
	(>15'-80')	(>80'-150')	
3/4	2	2	4
1	2	4" D.I.P.	4 / 12
1-1/2	N/A	N/A	N/A
2	N/A	N/A	N/A

(Feet refer to distance from water main to meter)

TAMPA WATER DEPARTMENT	APPROVED	REVISED	SINGLE & DUAL METERED SERVICE - LONG SIDE 3/4", 1", 1-1/2" AND 2" W/HDPE PIPE	8.10
	Sept. 2011	_____		
	_____	_____		